

RE 27 219/12.02

Replaces: 07.97

Throttle and throttle check valve
Types MG / MK

Nominal sizes 6 to 30

Series 1X

Maximum operating pressure 315 bar

Maximum flow 400 L/min

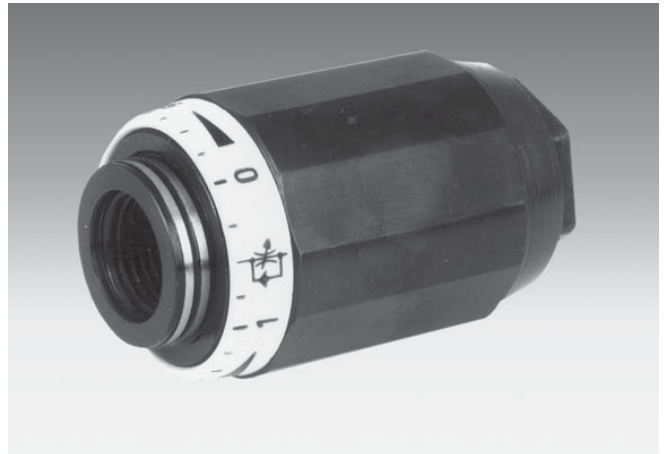

K 3564-1

Type MK . G1X/V

Overview of contents

Contents	Page
Features	1
Ordering details	1
Preferred types	2
Symbols	2
Function, section	2
Technical data	3
Characteristic curves	3
Unit dimensions	4

Features

- Suitable for direct in-line mounting
- Pressure and viscosity dependent

Ordering details

		G	1X/V	*
Throttle valve	= MG			
Throttle check valve	= MK			
Nominal size 6	= 6			
Nominal size 8	= 8			
Nominal size 10	= 10			
Nominal size 15	= 15			
Nominal size 20	= 20			
Nominal size 25	= 25			
Nominal size 30	= 30			
For threaded connections		= G		

V = Further details in clear text
FKM seals
(other seals on request)

⚠ Attention!
The compatibility of the seals and pressure fluid has to be taken into account!

1X = Series 10 to 19
(10 to 19: unchanged installation and connection dimensions)

Preferred types, see page 2, are readily available!



© 2002
by Bosch Rexroth AG, Industrial Hydraulics, D-97813 Lohr am Main

All rights reserved. No part of this document may be reproduced or stored, processed, duplicated or circulated using electronic systems, in any form or by means, without the prior written authorisation of Bosch Rexroth AG. In the event of contravention of the above provisions, the contravening party is obliged to pay compensation.

This document was prepared with the greatest of care, and all statements have been examined for correctness. This document is subject to alterations for reason of the continuing further developments of products. No liability can be accepted for any incorrect or incomplete statements.

Preferred types (readily available)

Type MG	Material No.
MG 6 G1X/V	R900437338
MG 8 G1X/V	R900438885
MG 10 G1X/V	R900422145
MG 15 G1X/V	R900437653
MG 20 G1X/V	R900422150
MG 25 G1X/V	R900413979
MG 30 G1X/V	R900422153

Type MK	Material No.
MK 6 G1X/V	R900423340
MK 8 G1X/V	R900423343
MK 10 G1X/V	R900424579
MK 15 G1X/V	R900423326
MK 20 G1X/V	R900423328
MK 25 G1X/V	R900423330
MK 30 G1X/V	R900423333

Further preferred types and standard units can be found in the EPS (Standard Price List).

Symbols



Type MG

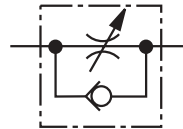

Type MK

Function, section

Valve types MG and MK are pressure and viscosity dependent throttle and throttle check valves.

Type MG (throttle valve)

This valve throttles in both flow directions. The pressure fluid flows through side drillings (3) to the throttling point (4). This is formed between the housing (2) and the adjustable sleeve (1). The throttle cross-section (4) may be steplessly varied by rotating the sleeve (1).

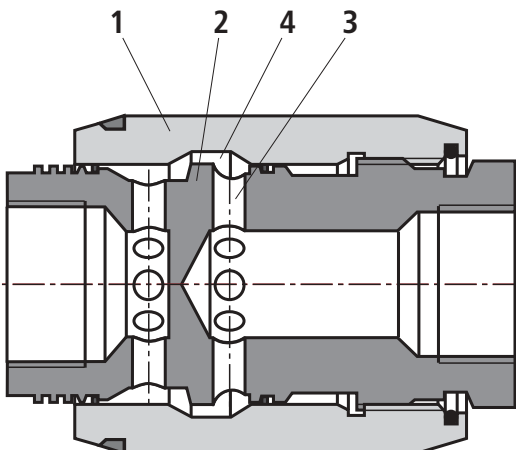

Throttle valve type MG

Type MK (throttle check valve)

With flow passing through the valve in throttling direction, the spring (6) and the pressure fluid presses the poppet (5) onto its seat, thus blocking the flow. Pressure fluid flows via the side drillings (3) to the throttling point (4), which is formed between the housing (2) and the adjustable sleeve (1).

In the opposite direction, the fluid pressure acts on the face of the poppet (5), thus lifting it from its seat and allowing fluid to flow freely, unthrottled, through the valve. At the same time, part of the pressure fluid flowing through the annular clearance produces the desired self-cleaning effect.

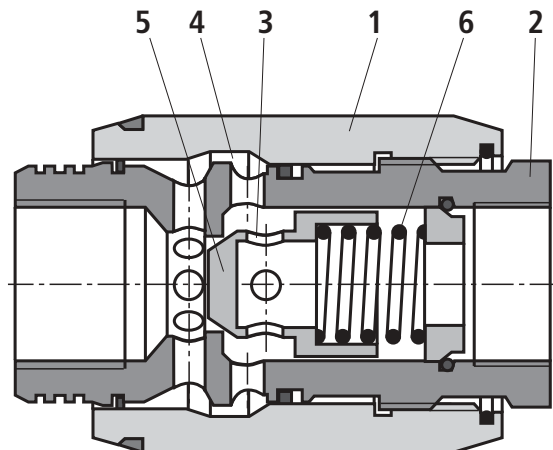

Throttle check valve

Technical data (for applications outside these parameters, please consult us!)

General

Installation	Optional							
Ambient temperature range	°C	- 20 to + 80						
Weight	NS	6	8	10	15	20	25	30
	kg	0.3	0.4	0.7	1.1	1.9	3.2	4.1

Hydraulic

Maximum operating pressure	bar	315
Opening pressure for type MK	bar	0.5
Maximum flow	L/min	400
Pressure fluid	Mineral oil (HL, HLP) to DIN 51 524; Fast bio-degradable pressure fluids to VDMA 24 568 (also see RE 90 221); HETG (rape seed oil); HEPG (polyglycols); HEES (synthetic ester); Other pressure fluids on request	
Pressure fluid temperature range	°C	- 20 ... + 80
Viscosity range	mm ² /s	10 ... 800
Cleanliness class to ISO code	Maximum permissible degree of contamination of the pressure fluid is to ISO 4406 (C) class 20/18/15 ¹⁾	

¹⁾ The cleanliness class stated for the components must be adhered too in hydraulic systems. Effective filtration prevents faults from occurring and at the same time increases the component service life.
For the selection of filters see catalogue sheets RE 50 070, RE 50 076 and RE 50 081.

Characteristic curves (measured with HLP46, $\vartheta_{oil} = 40 \text{ °C} \pm 5 \text{ °C}$)

Δp - q_v -characteristic curves via the open check valve with the throttle closed (type MK)

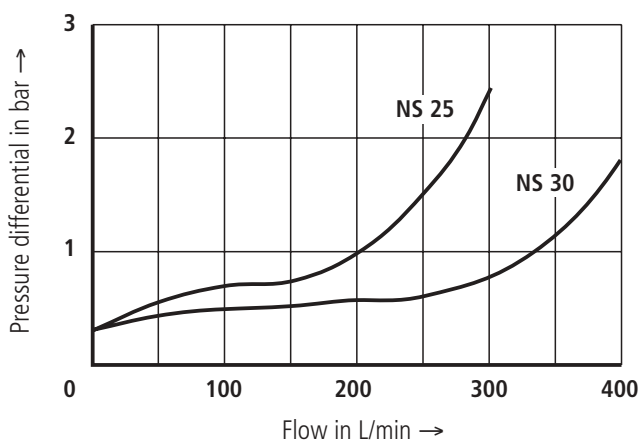
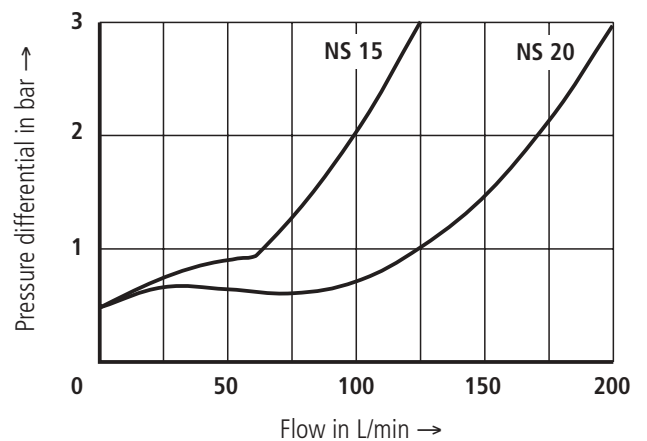
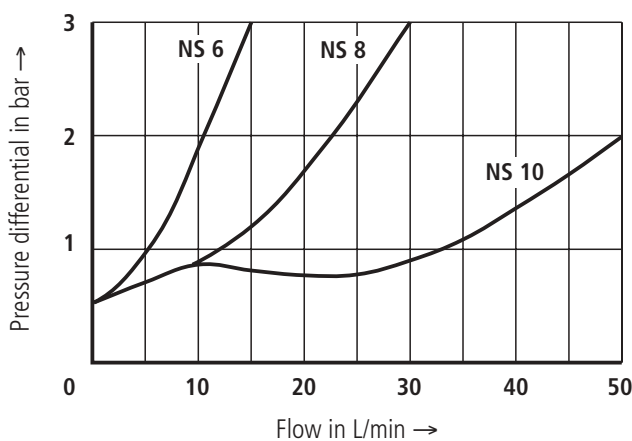

Characteristic curves (measured with HLP46, $\vartheta_{oil} = 40 \text{ }^\circ\text{C} \pm 5 \text{ }^\circ\text{C}$)

Δp - q_v -characteristic curves via the open throttle (types MG and MK)

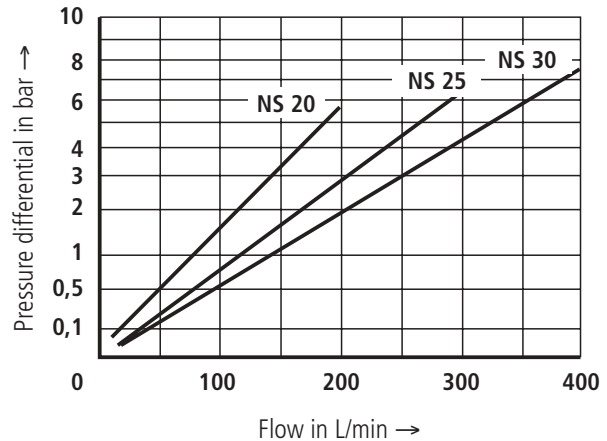
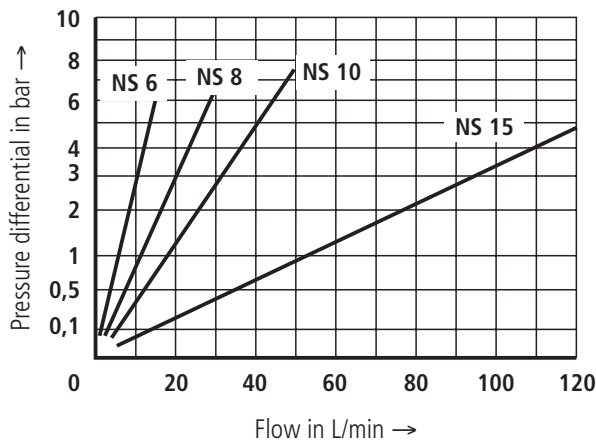

Unit dimensions (dimensions in mm)

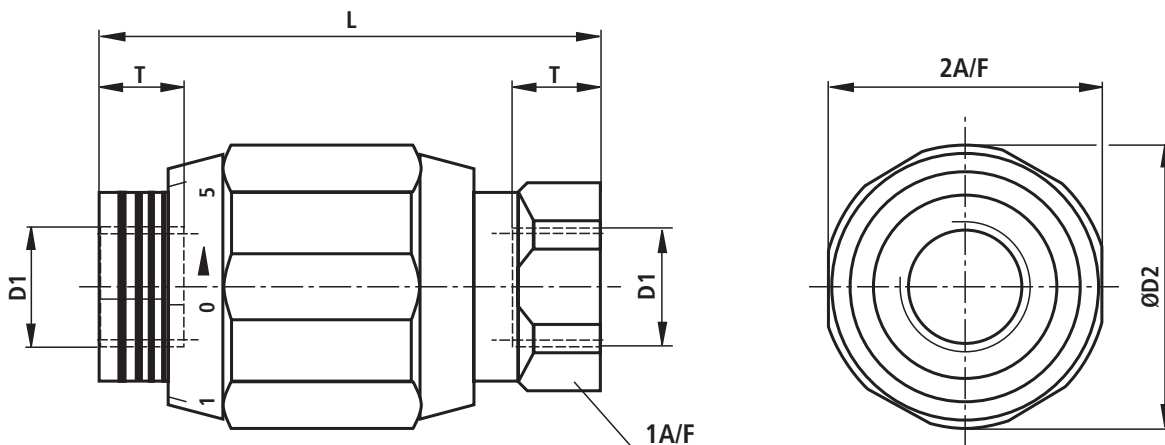

NS	D1	Ø D2	L	1A/F	2A/F	T
6	G 1/4	34	65	22	32	12
8	G 3/8	38	65	24	36	12
10	G 1/2	48	80	30	46	14
15	G 3/4	58	100	41	55	16
20	G 1	72	110	46	70	18
25	G 1 1/4	87	130	55	85	20
30	G 1 1/2	93	150	60	90	22

**Bosch Rexroth AG
Industrial Hydraulics**

D-97813 Lohr am Main
 Zum Eisengießer 1 • D-97816 Lohr am Main
 Telefon 0 93 52 / 18-0
 Telefax 0 93 52 / 18-23 58 • Telex 6 89 418-0
 eMail documentation@boschrexroth.de
 Internet www.boschrexroth.de

Bosch Rexroth Limited

Cromwell Road, St Neots,
 Cambs, PE19 2ES
 Tel: 0 14 80/22 32 56
 Fax: 0 14 80/21 90 52
 E-mail: info@boschrexroth.co.uk

The data specified above only serves to describe the product. No statements concerning a certain condition or suitability for a certain application can be derived from our information. It must be remembered that our products are subject to a natural process of wear and ageing.