



DSA*

PNEUMATICALLY OPERATED DIRECTIONAL CONTROL VALVE

SUBPLATE MOUNTING

DSA3 ISO 4401-03 (CETOP 03)

DSA5 ISO 4401-05 (CETOP R05)

p max (see performances table)

Q nom (see performances table)

MOUNTING INTERFACE DSA3

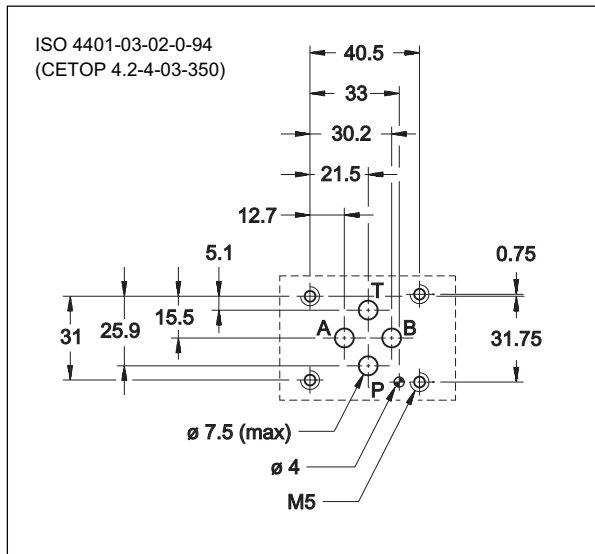

MOUNTING INTERFACE DSA5

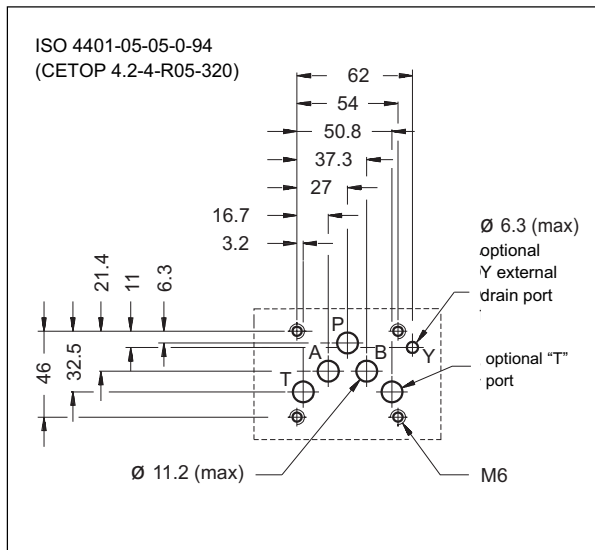

OPERATING PRINCIPLE

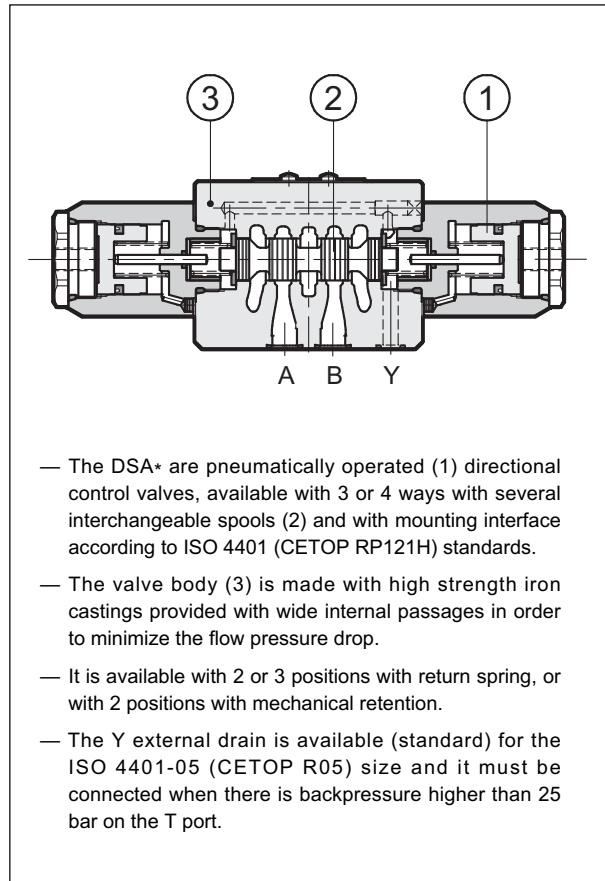



1 - IDENTIFICATION CODE

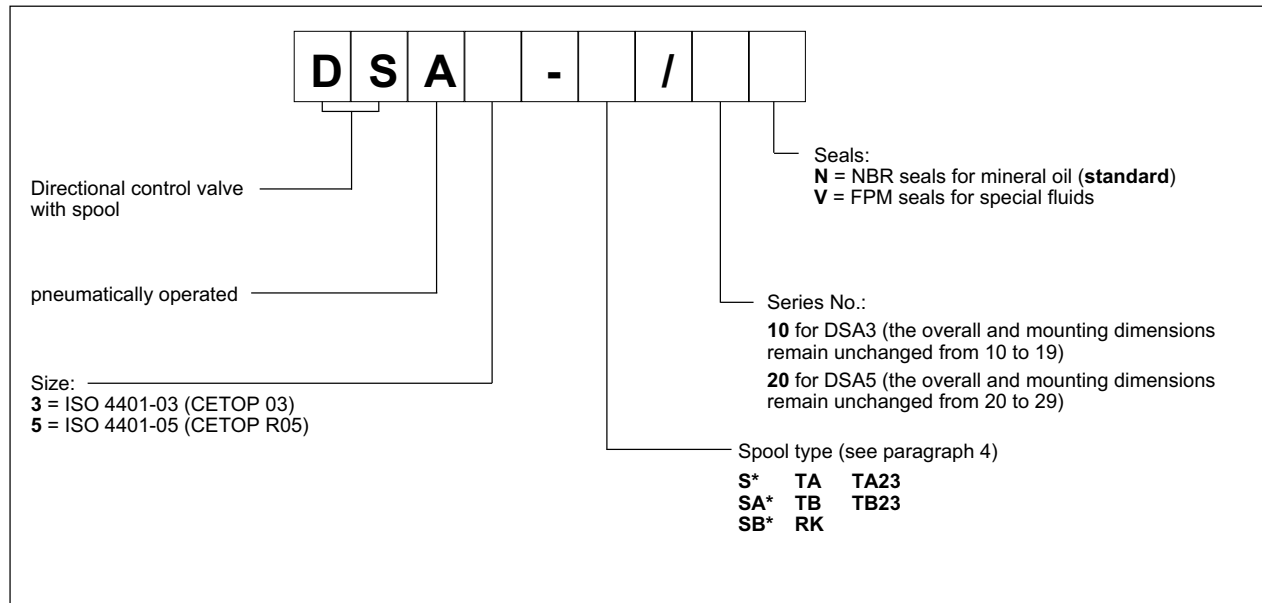

2 - PERFORMANCES (with mineral oil of viscosity 36 cSt at 50°C)

| | | | DSA3 | DSA5 |
|---|--|-------|---|-------------|
| Maximum working pressure: | | | | |
| - P A B ports | | bar | 350 | 320 |
| - T port without Y external drain (standard for DSA3) | | | 25 | 25 |
| - T port with Y external drain (only for DSA5) | | | - | 320 |
| Piloting pressure | min max | bar | 4 12 | 4,5 12 |
| Nominal flow | | l/min | 75 | 120 |
| Ambient temperature range | | °C | -20 / +50 | |
| Fluid temperature range | | °C | -20 / +80 | |
| Fluid viscosity range | | cSt | 10 ÷ 400 | |
| Recommended viscosity | | cSt | 25 | |
| Fluid contamination degree | | | according to ISO 4406:1999 class 20/18/15 | |
| Mass | single operation valve double operation valve | kg | 1,3 1,7 | 3,2 4,0 |

3 - HYDRAULIC FLUIDS

Use mineral oil-based hydraulic fluids HL or HM type, according to ISO 6743-4. For these fluids, use NBR seals (code N).

For fluids HFDR type (phosphate esters) use FPM seals (code V).

For the use of other fluid types such as HFA, HFB, HFC, please consult our technical department.

Using fluids at temperatures higher than 80 °C causes a faster degradation of the fluid and of the seals characteristics.

The fluid must be preserved in its physical and chemical characteristics.



4 - SPOOL TYPE

Type S*:
2 operations - 3 positions
with spring centering

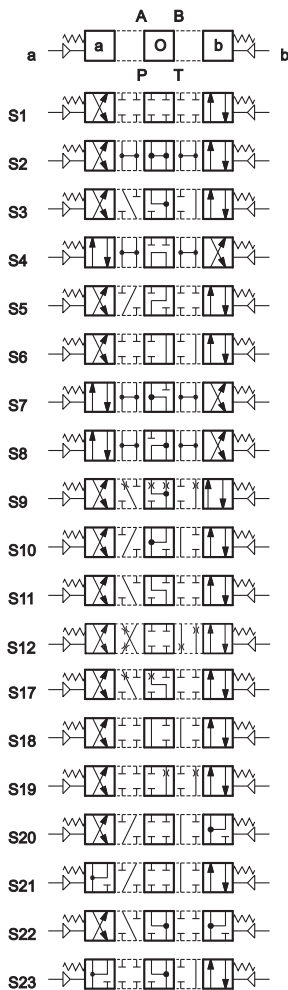

Type SA*:
1 operation side A
2 positions (central + external)
with spring centering

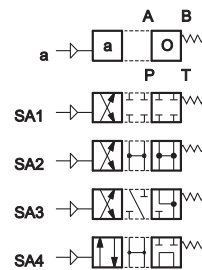

Type SB*:
1 operation side B
2 positions (central + external)
with spring centering

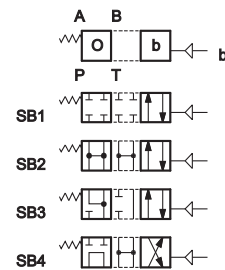

Type TA:
1 operation side A
2 external positions
with return spring

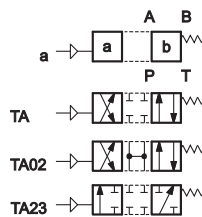

Type TB:
1 operation side B
2 external positions
with return spring

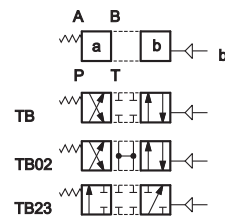

Type RK:
2 operations - 2 positions
with mechanical retention

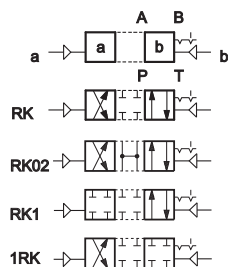

Besides the diagrams shown, which are the most frequently used, other special versions are available: consult our technical department for their identification and operating limits.



5 - PRESSURE DROPS Δp -Q (values obtained with viscosity 36 cSt at 50 °C)

5.1 - Pressure drops Δp -Q DSA3

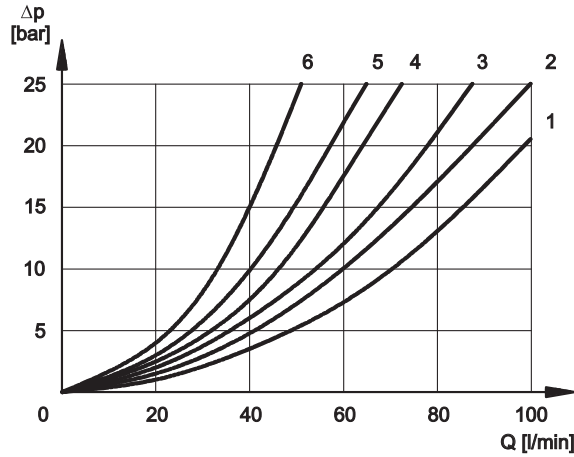

For pressure drops between A and B lines of spools S10, S20, S21, S22 and S23, which are used in the regenerative diagram, refer to curve 5.

PRESSURE DROPS WITH VALVE IN ENERGIZED POSITION

| SPOOL TYPE | FLOW DIRECTION | | | |
|--------------|-----------------|-----|-----|-----|
| | P-A | P-B | A-T | B-T |
| | CURVES ON GRAPH | | | |
| S1, SA1, SB1 | 2 | 2 | 3 | 3 |
| S2, SA2, SB2 | 1 | 1 | 3 | 3 |
| S3, SA3, SB3 | 3 | 3 | 1 | 1 |
| S4, SA4, SB4 | 6 | 6 | 6 | 6 |
| S5 | 2 | 1 | 3 | 3 |
| S6 | 2 | 2 | 3 | 1 |
| S7, S8 | 6 | 6 | 6 | 6 |
| S9 | 2 | 2 | 3 | 3 |
| S10 | 1 | 3 | 1 | 3 |
| S11 | 2 | 2 | 1 | 3 |
| S12 | 2 | 2 | 3 | 3 |
| S17 | 2 | 2 | 3 | 3 |
| S18 | 1 | 2 | 3 | 3 |
| S19 | 2 | 2 | 3 | 3 |
| S20 | 1 | 5 | 2 | |
| S21 | 5 | 1 | | 2 |
| S22 | 1 | 5 | 2 | |
| S23 | 5 | 1 | | 2 |
| TA, TB | 2 | 2 | 2 | 2 |
| TA02, TB02 | 2 | 2 | 2 | 2 |
| TA23, TB23 | 3 | 3 | | |
| RK | 2 | 2 | 2 | 2 |
| RK02 | 2 | 2 | 2 | 2 |
| RK1, 1RK | 2 | 2 | 2 | 2 |

PRESSURE DROPS WITH VALVE IN DE-ENERGIZED POSITION

| SPOOL TYPE | FLOW DIRECTION | | | | |
|--------------|-----------------|-----|-----|-----|-----|
| | P-A | P-B | A-T | B-T | P-T |
| | CURVES ON GRAPH | | | | |
| S2, SA2, SB2 | | | | | 2 |
| S3, SA3, SB3 | | | 3 | 3 | |
| S4, SA4, SB4 | | | | | 5 |
| S5 | | 4 | | | |
| S6 | | | | 3 | |
| S7, S8 | | | | | 5 |
| S10 | 3 | 3 | | | |
| S11 | | | 3 | | |
| S18 | 4 | | | | |
| S22 | | | 3 | 3 | |
| S23 | | | 3 | 3 | |



5.2 - Pressure drops Δp -Q DSA5

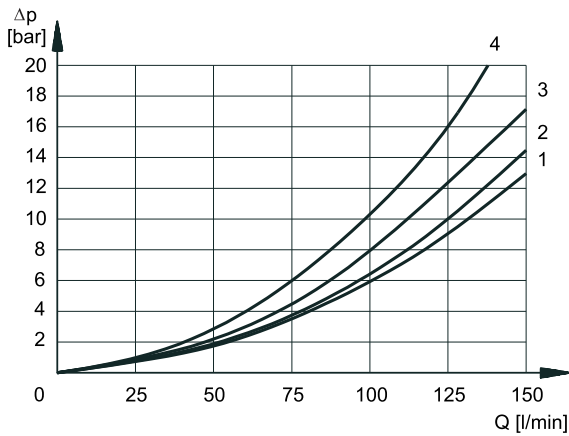

PRESSURE DROPS WITH VALVE IN ENERGIZED POSITION

| SPOOL TYPE | FLOW DIRECTION | | | |
|--------------|-----------------|-----|-----|-----|
| | P-A | P-B | A-T | B-T |
| | CURVES ON GRAPH | | | |
| S1, SA1, SB1 | 2 | 2 | 1 | 1 |
| S2, SA2, SB2 | 3 | 3 | 1 | 1 |
| S3, SA3, SB3 | 3 | 3 | 2 | 2 |
| S4, SA4, SB4 | 1 | 1 | 2 | 2 |
| S5 | 2 | 1 | 1 | 1 |
| S6, S11 | 3 | 3 | 2 | 2 |
| S7, S8 | 1 | 1 | 2 | 2 |
| S9 | 3 | 3 | 2 | 2 |
| S10 | 1 | 1 | 1 | 1 |
| S12 | 2 | 2 | 1 | 1 |
| S17, S19 | 2 | 2 | 1 | 1 |
| S18 | 1 | 2 | 1 | 1 |
| S20, S21 | | | | |
| S22, S23 | | | | |
| TA, TB | 3 | 3 | 2 | 2 |
| TA02, TB 02 | 3 | 3 | 2 | 2 |
| TA23, TB23 | 4 | 4 | | |
| RK | 3 | 3 | 2 | 2 |
| RK02 | 3 | 3 | 2 | 2 |
| RK1, 1RK | 3 | 3 | 2 | 2 |

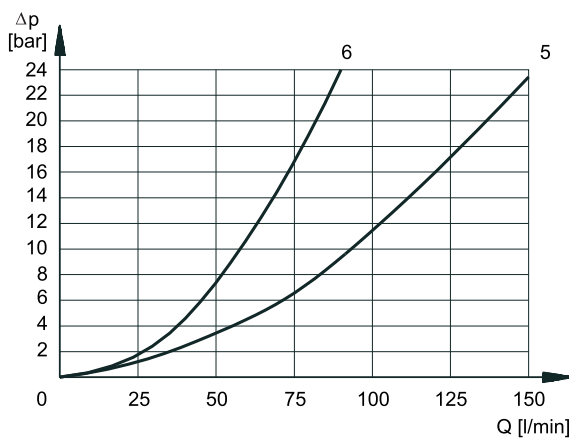

PRESSURE DROPS WITH VALVE IN DE-ENERGIZED POSITION

| SPOOL TYPE | FLOW DIRECTION | | | | |
|--------------|-----------------|-----|-----|-----|-----|
| | P-A | P-B | A-T | B-T | P-T |
| | CURVES ON GRAPH | | | | |
| S2, SA2, SB2 | | | | | 5 |
| S3, SA3, SB3 | | | 6 | 6 | |
| S4, SA4, SB4 | | | | | 5 |
| S5 | | 3 | | | |
| S6 | | | | 6 | |
| S7 | | | | | 5 |
| S8 | | | | | 5 |
| S10 | 3 | 3 | | | |
| S11 | | | 6 | | |
| S18 | 3 | | | | |
| S22 | | | | | |
| S23 | | | | | |



6 - OPERATING LIMITS

The curves define the flow rate operating fields according to the valve pressure of the different versions. The values have been obtained according to ISO 6403 norm, with mineral oil viscosity 36 cSt at 50 °C and filtration according to ISO 4406:1999 class 18/16/13.

6.1 - DSA3

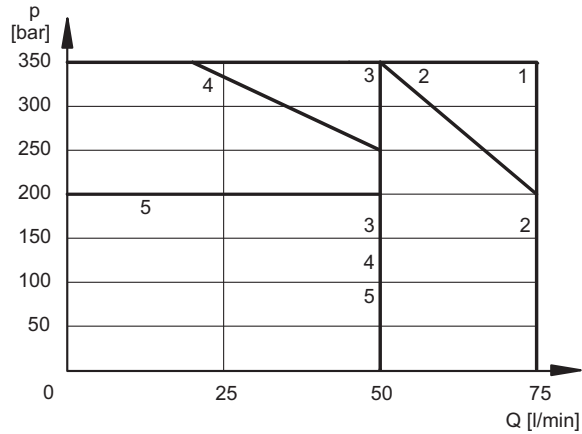

| SPOOL TYPE | CURVE | |
|--------------|-------|-----|
| | P-A | P-B |
| S1,SA1,SB1 | 1 | 1 |
| S2, SA2, SB2 | 1 | 1 |
| S3, SA3, SB3 | 2 | 2 |
| S4, SA4, SB4 | 3 | 3 |
| S5 | 1 | 1 |
| S6 | 3 | 2 |
| S7 | 3 | 3 |
| S8 | 3 | 3 |
| S9 | 1 | 1 |
| S10 | 1 | 1 |
| S11 | 2 | 3 |
| S12 | 1 | 1 |

| SPOOL TYPE | CURVE | |
|------------|-------|-----|
| | P-A | P-B |
| S17 | 1 | 1 |
| S18 | 1 | 1 |
| S19 | 1 | 1 |
| S20 | 4 | 4 |
| S21 | 4 | 4 |
| S22 | 5 | 4 |
| S23 | 4 | 5 |
| TA, TB | 1 | 1 |
| TA02, TB02 | 1 | 1 |
| TA23, TB23 | 1 | 1 |
| RK | 1 | 1 |
| RK02 | 1 | 1 |
| RK1, 1RK | 1 | 1 |

6.2 - DSA5

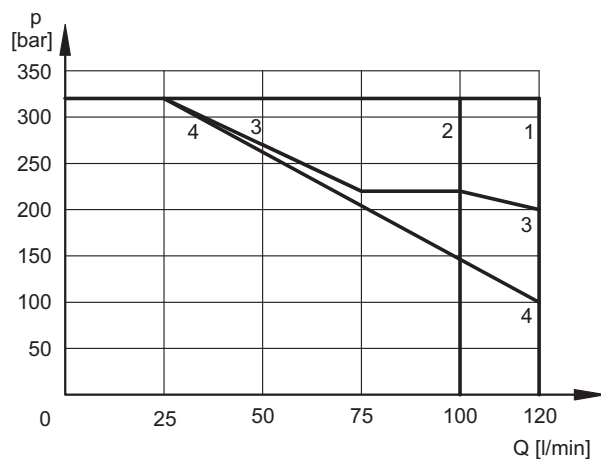

| SPOOL TYPE | CURVE | |
|--------------|-------|-----|
| | P-A | P-B |
| S1,SA1,SB1 | 1 | 1 |
| S2, SA2, SB2 | 1 | 1 |
| S3, SA3, SB3 | 3 * | 3 * |
| S4, SA4, SB4 | 4 | 4 |
| S5 | | |
| S6 | | |
| S7 | | |
| S8 | | |
| S9 | | |
| S10 | | |
| S11 | | |
| S12 | | |

| SPOOL TYPE | CURVE | |
|------------|-------|-----|
| | P-A | P-B |
| S17 | | |
| S18 | | |
| S19 | | |
| S20 | | |
| S21 | | |
| S22 | | |
| S23 | | |
| TA, TB | 2 * | 2 * |
| TA02, TB02 | | |
| TA23, TB23 | | |
| RK | | |
| RK02 | | |
| RK1, 1RK | | |

* **NOTE:** for spools S3 and TA, the curve has been obtained with a min. piloting pressure of 4,5 bar. If the minimum piloting pressure used is 5,5 bar, refer to the curve n° 1 (320 bar - 120 l/min).

NOTE: The values indicated in the graphs are relevant to the standard valve. The operating limits can be considerably reduced if a 4-way valve is used with port A or B plugged.



7 - INSTALLATION

Configurations with centering and return springs can be mounted in any position; type RK valves - without springs and with mechanical detent - must be mounted with the longitudinal axis horizontal. Valve fixing is by means of screws or tie rods, with the valve mounted on a lapped surface, with values of planarity and smoothness that are equal to or better than those indicated in the drawing. If the minimum values of planarity and/or smoothness are not met, fluid leakage between valve and mounting surface can easily occur.

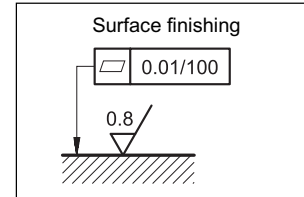

8 - OVERALL AND MOUNTING DIMENSIONS DSA3

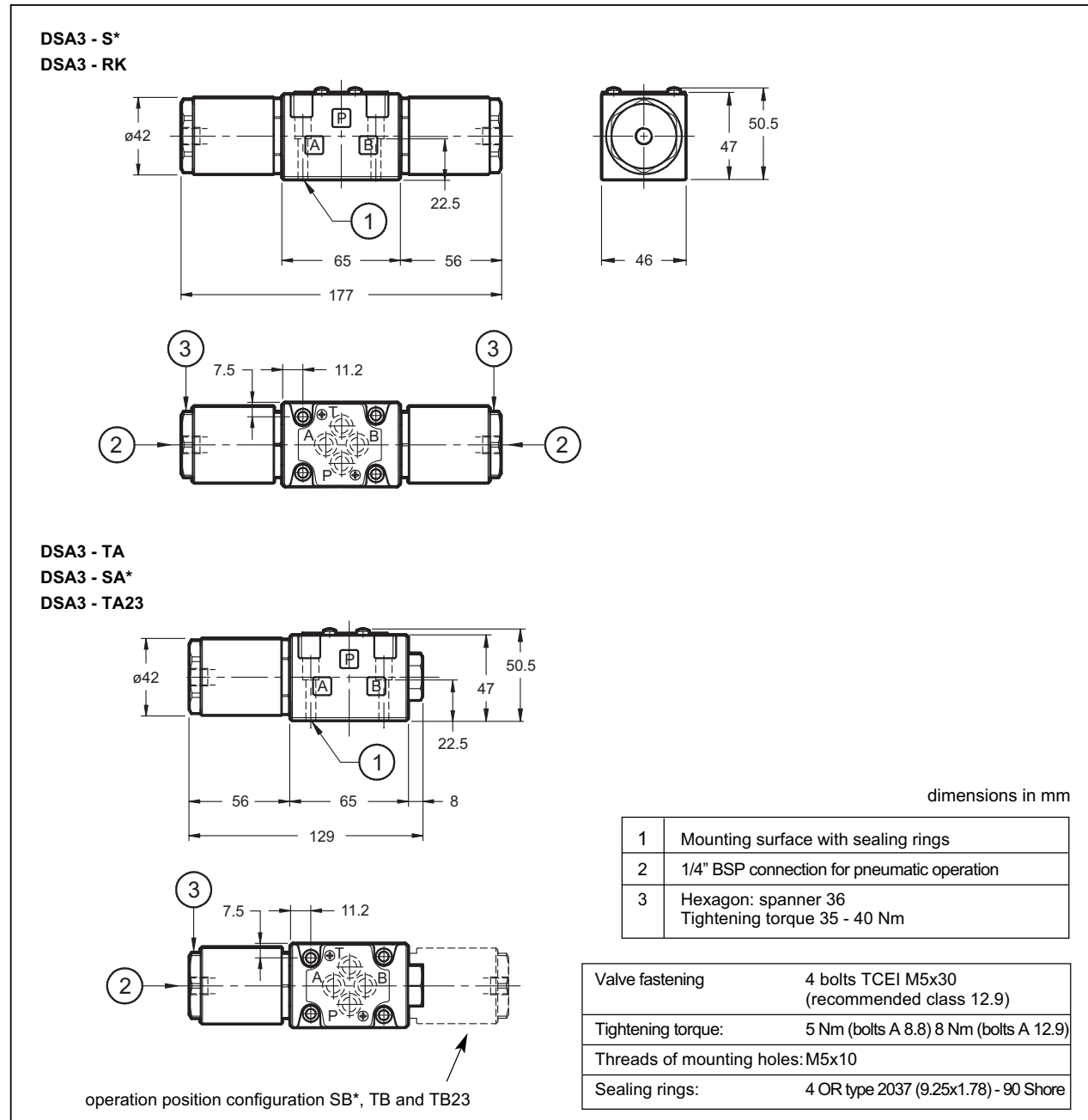



DSA*

9 - OVERALL AND MOUNTING DIMENSIONS DSA5

DSA5 - S*
DSA5 - RK

DSA5 - TA
DSA5 - SA*
DSA5 - TA23

dimensions in mm

| | |
|---|---|
| 1 | Mounting surface with sealing rings |
| 2 | 1/4" BSP connection for pneumatic operation |
| 3 | Hexagon: spanner 41 Tightening torque 55 - 60 Nm |

| | |
|----------------------------|---|
| Valve fastening: | 4 screws TCEI M6x40 (recommended class 12.9) |
| Tightening torque: | 8 Nm (bolts A 8.8) - 14 Nm (bolts A 12.9) |
| Threads of mounting holes: | M6x10 |
| Sealing rings: | 5 OR type 2050 (12.42x1.78) - 90 Shore 1 OR type 2037 (9.25x1.78) - 90 Shore |

operation position configuration SB*, TB and TB23

| 10 - SUBPLATES (See catalogue 51 000) | DSA3 | DSA5 |
|---------------------------------------|-----------|-----------|
| Type with rear ports | PMMD-AI3G | PMD4-AI4G |
| Type with side ports | PMMD-AL3G | PMD4-AL4G |
| Threading of ports P, T, A, B, | 3/8" BSP | 1/2" BSP |

| | |
|--|--|
| | <p>DIPLOMATIC OLEODINAMICA SpA 20025 LEGNANO (MI) - P.le Bozzi, 1 / Via Edison Tel. 0331/472111 - Fax 0331/548328</p> |
|--|--|