 www.khadamathydraulic.com
Tell: 021-55882749
Tell: 021-33488178
Fax: 021-33488105

DENISON HYDRAULICS

Proportional Pressure Reducing Valves

Series 4RP01 – Design D – Cetop 03

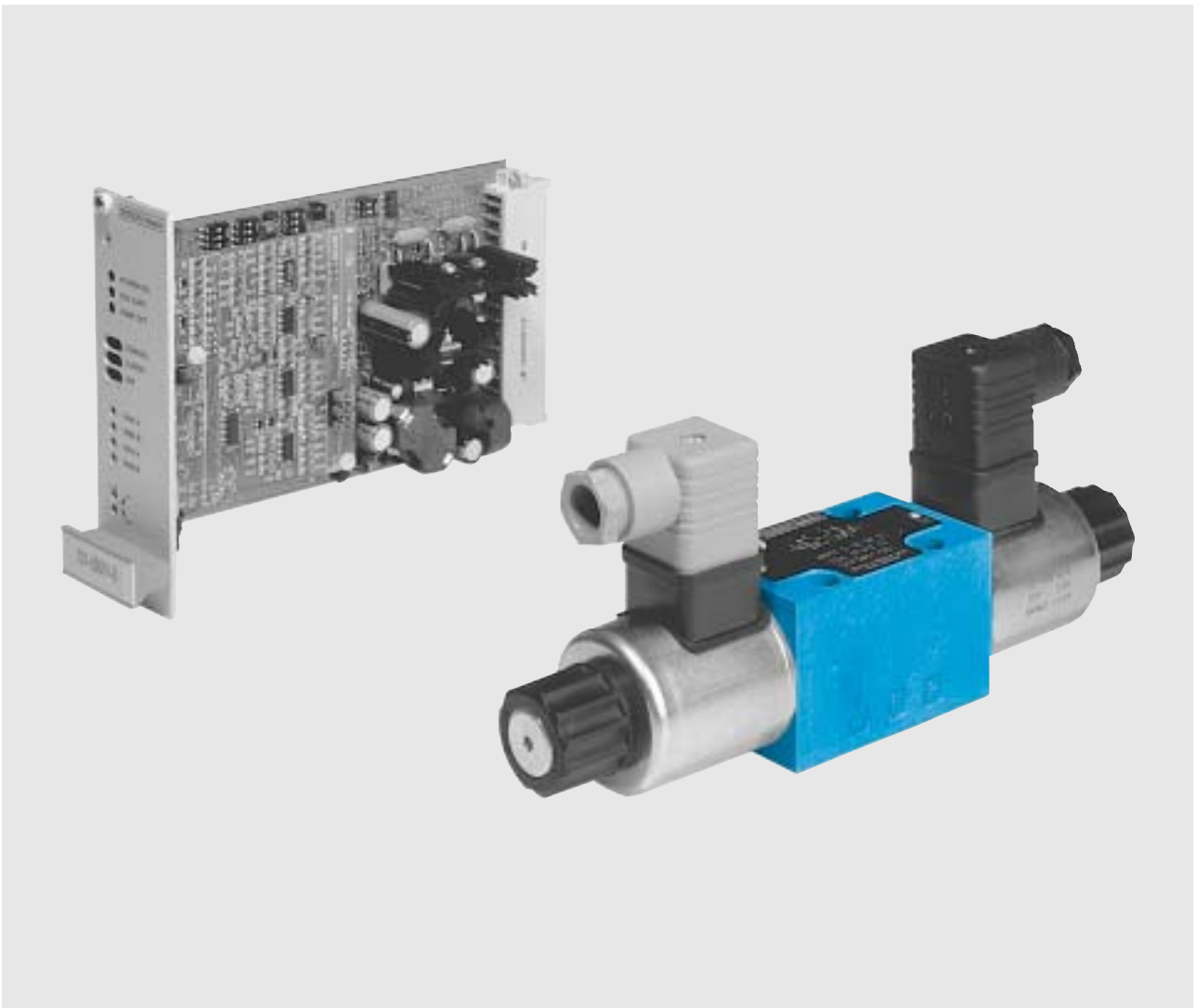

Publ. 3-EN 2800-B, replaces 3-EN 2800-A

DENISON Hydraulics

FEATURES, DESCRIPTION

FEATURES

- Electric-proportional adjustment of secondary pressures in working ports A and B.
- Three pressure ranges, giving higher resolution:
 - 0... 16 bar
 - 0... 25 bar
 - 0... 45 bar
- Also ideal as pilot stage for systems with "barometric" feedback.
- Economic operation of systems-power saving.
- Valve and electronics from one supplier ensures optimal performance.
- Electrical connection is by a standard plug-in connector conform to ISO 4400.
- Mounting configuration conform to ISO.
- Easy assembly – no dynamic loaded seals.
- Each valve is factory tested prior to shipping.
- Full interchangeability of spools with close tolerances.
- Worldwide DENISON service.

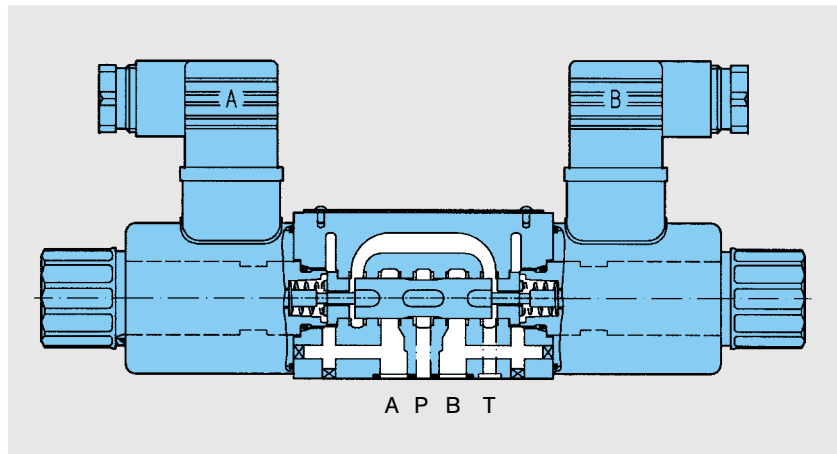

DESCRIPTION

The proportional pressure reducing valves, series 4RP01, are direct operated by proportional solenoids and are, therefore, dynamically independent from pilot oil or supply pressure.

In de-energized condition the spool is kept in neutral position by springs. Energizing solenoid "a" the secondary pressure is controlled in port "B", energizing solenoid "b" the secondary pressure is controlled in port "A".

The force balance determines the position of the regulating edge of the main spool, e. g. solenoid "a" effects opening and flow from P to B. The increasing secondary pressure in B is connected to the spring chamber and acts against the small feedback area of the main spool. The main spool remains in its position when solenoid force and the force generated by the feedback pressure is in balance.

Each electrical input signal to the solenoid controls a secondary pressure proportionally at the corresponding valve outlet A or B.

Refer also to curves on page 5.

ELECTRONIC

The proportional amplifiers developed together with the valves are shown in this brochure with schematic block diagram and terminal connections as well as accessories.

TECHNICAL DATA

GENERAL AND HYDRAULIC CHARACTERISTICS

• Design	Sliding spool valve with force balance, proportionally controlled
• Mounting position	Optional but horizontal optimal
• Type of mounting	Subplate body conform to ISO 4401 / Cetop 03
• Operating pressure in P p _{max} p _{min}	Primary pressure: 100 bar 20 bar for pressure range 0... 16 bar 30 bar for pressure range 0... 25 bar 50 bar for pressure range 0... 45 bar
• Flow max.	13 l/min at Δ p = 50 bar
• Fluid temperature range	- 18... + 80 °C
• Ambient temperature range	- 10... + 50 °C
• Viscosity range	10... 650 cSt; optimal 30 cSt
• Hysteresis	≅ 3 % at Δ p = 100 bar
• Repeatability	≅ 1 % at Δ p = 100 bar
• Fluid	Petroleum base anti-wear fluids (covered by DENISON HF-0 and HF-2 specification). Such as mineral oil according to DIN 51524/ 25. Maximum catalogue ratings and performance data are based on operation with these fluids.
• Contamination level	Fluid must be cleaned before and continuously during operation by filters that maintain a cleanliness level of NAS 1638 Class 8 (Class 9 for 15 Micron and smaller). This approximately corresponds to ISO 17/14. Better cleanliness levels will significantly extend the life of the components. As contaminant entrainment and contaminant generation may vary with each application, each must be analyzed to determine proper filtration to maintain the required cleanliness level.

ELECTRIC CHARACTERISTICS

• Type of voltage (DC)	12 V
• Coil resistance - cold start 20 °C - warm value 50 °C	3.7 Ω 4.5 Ω
• Nominal current	2.2 A
• Max. current	2.5 A
• Max. coil temperature (temp. class F)	+ 155 °C
• Type of protection (DIN 40050)	IP 65
• Relative operating period	100 %

ORDERING CODE

Model No.: 4RP01 . .. G12 D

1	Series _____	1	2	3	4	5	6	7	8
1	<p>Series _____</p> <p>01 = Cetop 03</p>								
2	<p>Control _____</p> <p>A = solenoid on side "a" pressure reducing at B</p> <div style="border: 1px dashed black; padding: 5px; margin: 5px 0;"> </div> <p>B = solenoid on side "b" pressure reducing at A</p> <div style="border: 1px dashed black; padding: 5px; margin: 5px 0;"> </div> <p>D = solenoids on sides "a + b" pressure reducing at A + B</p> <div style="border: 1px dashed black; padding: 5px; margin: 5px 0;"> </div>								
3	<p>Pressure Range _____</p> <p>16 = 0... 16 bar 25 = 0... 25 bar 45 = 0... 45 bar</p>								
4	<p>Solenoid Voltage _____</p> <p>G12 = 12 V DC</p>								
5	<p>Design Letter _____</p>								
6	<p>Seal Class _____</p> <p>1 = NBR-Seals 5 = FPM-Seals (Viton®)</p>								
7	<p>Electrical Connector _____</p> <p>w/o code = connector not supplied C1 = connector PG 11</p>								
8	<p>Modifications _____</p> <p>without code = Tube cartridge with manual override N0 = Tube cartridge without manual override</p>								

CURVES

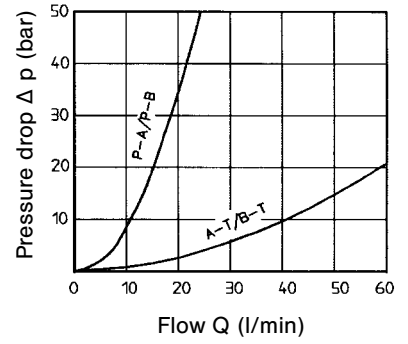
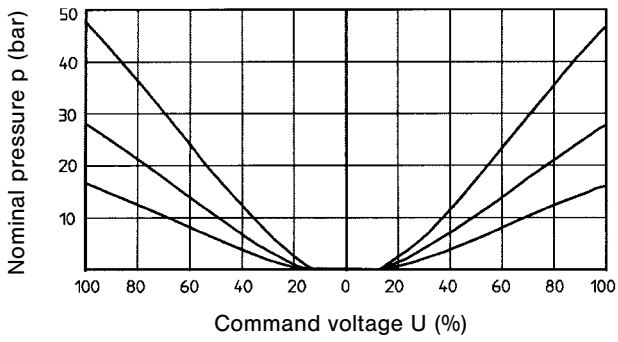

Pressure Range 0... 16 bar

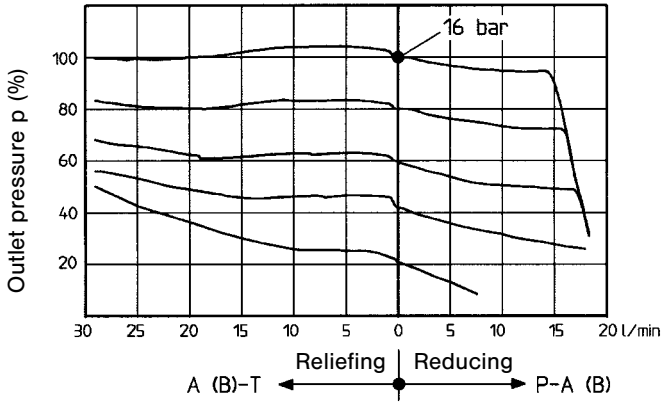

Pressure Range 0... 25 bar

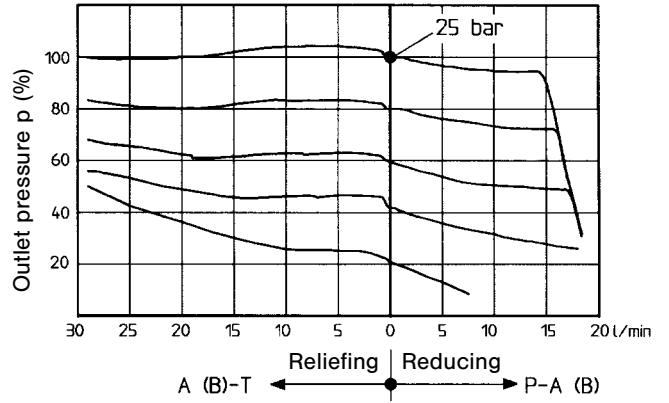

Pressure Range 0... 45 bar

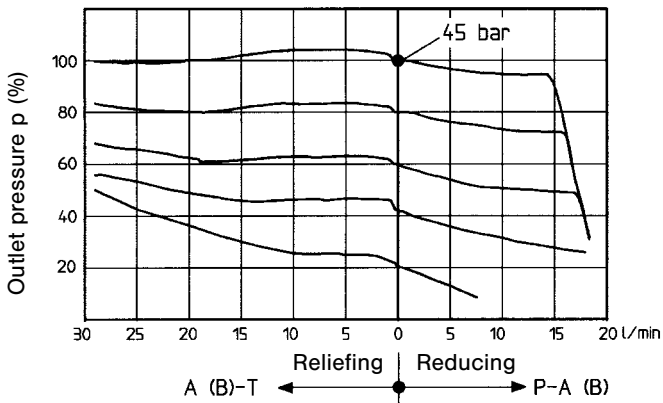

SUBPLATES

Mounting configuration conform to ISO

1/4" & 3/8" Subplates

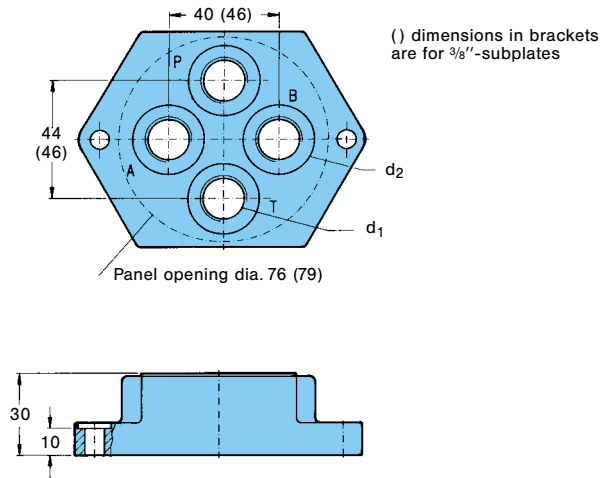

1/2" Subplates

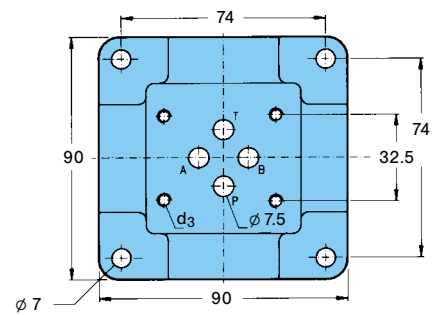
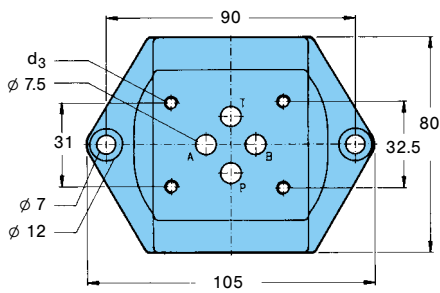
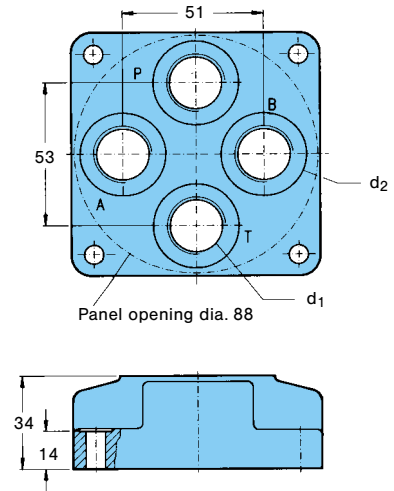

Model No.	Order No.	Weight	d ₁ (A, B, P, T)	d ₂	Thread for mounting screws d ₃
SS-B-04-G 136	S26-32959-0	1.4 kg	G 1/4"	∅ 23 x 1	M 5
SS-B-06-G 136	S26-32960-0	1.4 kg	G 3/8"	∅ 26 x 1	M 5
SS-B-08-G 136	S26-32961-0	1.7 kg	G 1/2"	∅ 31 x 1	M 5

Mounting screws are included in subplate order.

PROPORTIONAL AMPLIFIERS WITH RAMPS

Order No.: 701-00605-8
 one (1) 12 V solenoid
 Order No.: 701-00614-8
 two (2) 12 V solenoids
 Weight: 260 g



These proportional amplifiers are designed to control proportional pressure valves without position feedback and 12 V solenoids. They proportionally convert electrical input signals into solenoid current.

The amplifiers have a reverse polarity protection and one (or two) short circuit protected PWM-output stage(s) with max. current limit.

To operate a single solenoid proportional valve with the associated proportional amplifier only the output stage for solenoid A is fitted on the board.

The command signal input will be connected always to the same input line. The different kind of command signals will be set by DIP-switches on the main board. Potentiometers are intended for the adjustment of ramp circuits up/down (independently from each other), max. pressure (I_{max}) and min. pressure (I_{min}).

The zero-point adjustment enables the positive overlap of the spool, typical of proportional valves, to be bypassed. The electrical zero-point (I_{min}) can be adjusted to 0...50 % of I_{max} .

By changing the input signal from 0...2 % of max. command signal, the amplifier passes over to the "Imin-leap"-function (dead-band elimination).

There are diagnostic LED's to display the working condition (POWER ON), ramp function (RAMP OFF) and "FAIL SAFE" in case of short circuit or external STOP of the card. Two test sockets are provided to measure either the actual solenoid current or the command voltage.

Characteristics – Proportional Amplifiers

- Supply voltage
 - nominal 24 V DC
 - smoothed battery voltage 20...32 V DC
- Reference voltage
 - ± 15 V (± 5 %) @ 50 mA from amplifier
 - ± 10 V (± 0.5 %) @ 10 mA stabilised from amplifier
- Solenoid nominal current $I_{nom} = 2.2$ A at 100 % command signal
- Current consumption max. < 3 A for solenoid
- 12 V solenoid
- Short circuit protection
- Input signals

	1 solenoid	2 solenoids	Input impedance
1.	0...+20 mA = 0...+ 100 %	-20...0...+20 mA = - 100...0...+ 100 %	100 Ω
2.	+4...+20 mA = 0...+ 100 %	+4...+20 mA = - 100...0...+ 100 %	100 Ω
3.	0...+5 V = 0...+ 100 %	-5...0...+5 V = - 100...0...+ 100 %	100 k Ω
4.	0...+10 V = 0...+ 100 %	-10...0...+10 V = - 100...0...+ 100 %	200 k Ω
5.	customised selectable; R83 = 20 k Ω /V x Vcommand	customised selectable; R83 = 20 k Ω /V x Vcommand	value determined by R83

- Outputs
 - External stop (nom 24 V) illuminates on "FAIL SAFE", implement as NC (normally closed circuit) connection with an input voltage of 4 V...32 V; input impedance 3.3 k Ω
 - Ramp off (nom 24 V) illuminates when "RAMP OFF", implement as NO (normally open circuit) connection with an input voltage of 4 V...32 V; input impedance 3.3 k Ω
- Potentiometer for
 - max. pressure (I_{max} A, B) ...2.2 A
 - min. pressure (I_{min} A, B) 0... 50 % of I_{max} ; factory set 0 %
 - ramp up 0.2... 10 s ± 20 % (1... 50 V/s)
 - ramp down 0.2... 10 s ± 20 % (1... 50 V/s)
- Dither frequency selectable by DIP-switch (250 Hz factory set)
- Test socket
 - solenoid current 1 V $\cong 1$ A ± 5 %
 - command voltage approx. 0... 10 V at 100 % command signal (depends on I_{min} , I_{max} adjustment)

PROPORTIONAL AMPLIFIER WITH RAMPS

Dimensions Plug-in module 3U/8HP according to IEC 297

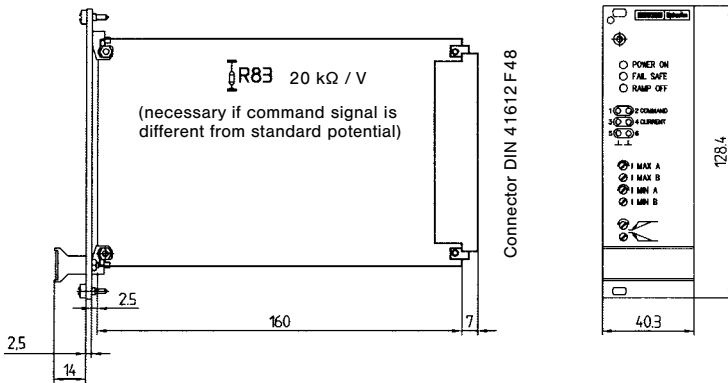

The output stages are short circuit protected. Short circuits at the outputs and supply input voltage falling below 20.5 V will result in the shutdown of the output stages, causing the "Fail Safe" LED come on. In this event, the supply voltage to the proportional amplifier must be switched off for a period of about 10 seconds.

Details on the front panel

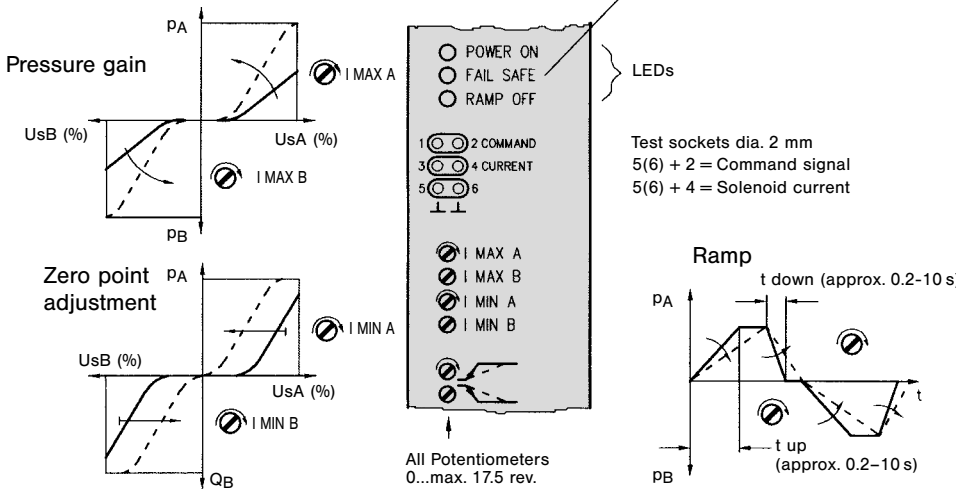

Schematic block diagram and terminal assignment

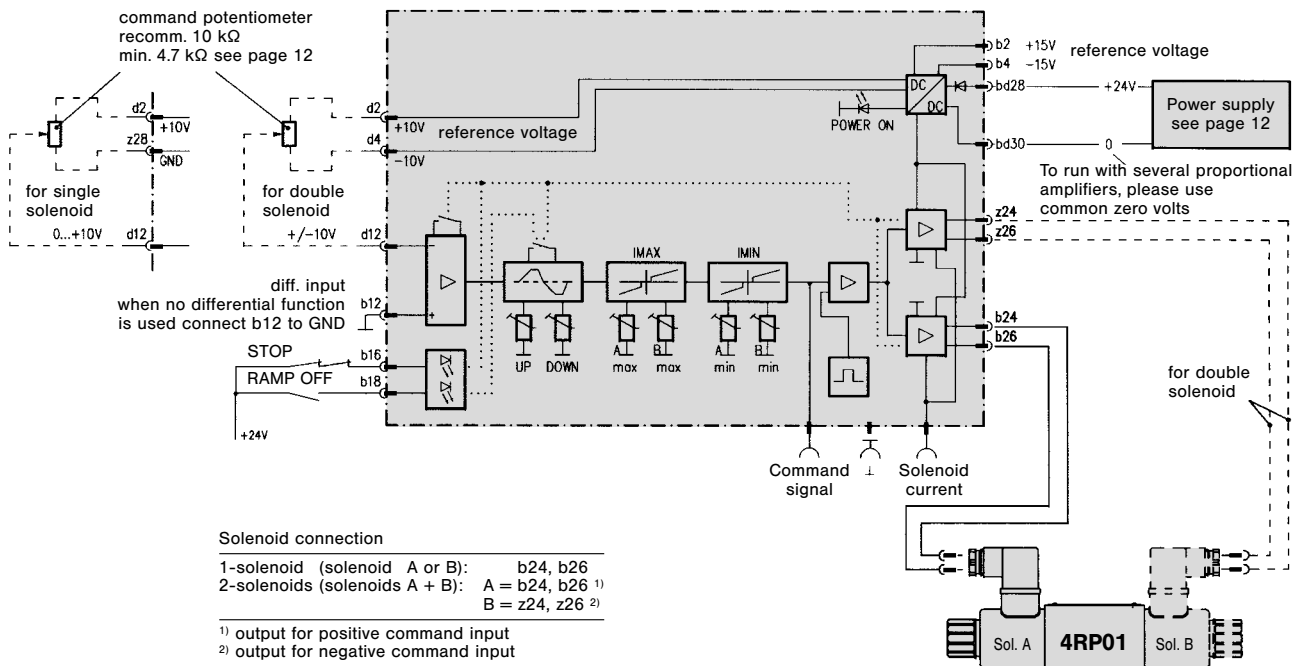

Note: For detail information see publ. 9-EN 6010 (1 solenoid version) see publ. 9-EN 6020 (2 solenoid version)

COMMAND CARD FIVE CHANNEL

Order No.: 701-00028-8
Weight: 150 g

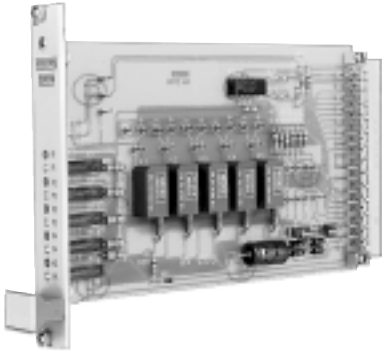

This command card is designed to interface with all proportional amplifiers for DENISON proportional valves.

Five multiturn-potentiometers (P1...P5) allow different command signals. Selection is made by external energizing of the five selector relays on the command card. By moving the solder bridges (+/-) it is possible to preset positive or negative commands for the desired level and direction.

In addition, the command card has a summing amplifier which enables the monitoring of the internal commands (solder bridges 1...5), or additional external resistor array.

These inputs (e.g. a 4) also make it possible to cascade further command cards if required.

The output signal to the proportional amplifier is available "not inverted" (a 2) and "inverted" (c 2).

The command card has a power rectifier with a 24 V DC output (input 24 V AC). Via this output c 30/32, the command relays can be energized.

All potentiometers are adjustable on the front panel.

The operating status of the corresponding command is indicated by an LED display on the front pannel (K1...K5).

LED on = Command level selected.

Characteristics – Command Card

- Supply voltage:
 - command card
 - rectifier
- Command potentiometer
- Command relays
- Relay contacts:
 - max. current on contact (resistive load) 100 mA
 - max. switching voltage 30 V
 - coil voltage 24 V DC, approx. 30 mA incl. LED-display

supply from proportional amplifier

24 V AC (min. 19 V AC)

5 potentiometers 0...10 V

5 potential – free contacts

Euro-Card-Holder

Order No. 701-00007-8
Holder for individual mounting according to DIN 41612 design D32

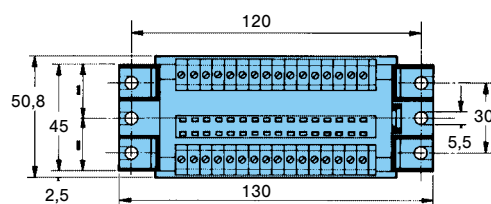
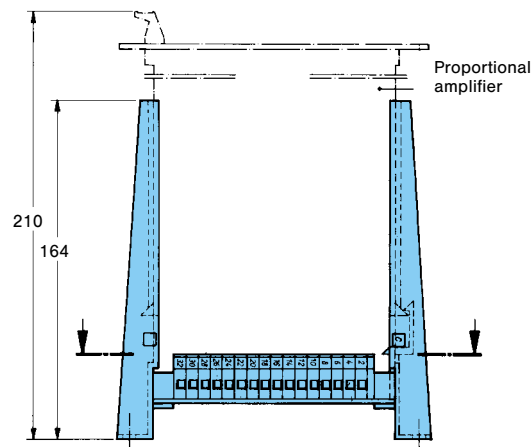

COMMAND CARD FIVE CHANNEL

Dimensions Plug-in module 3U/4HP according to IEC 297

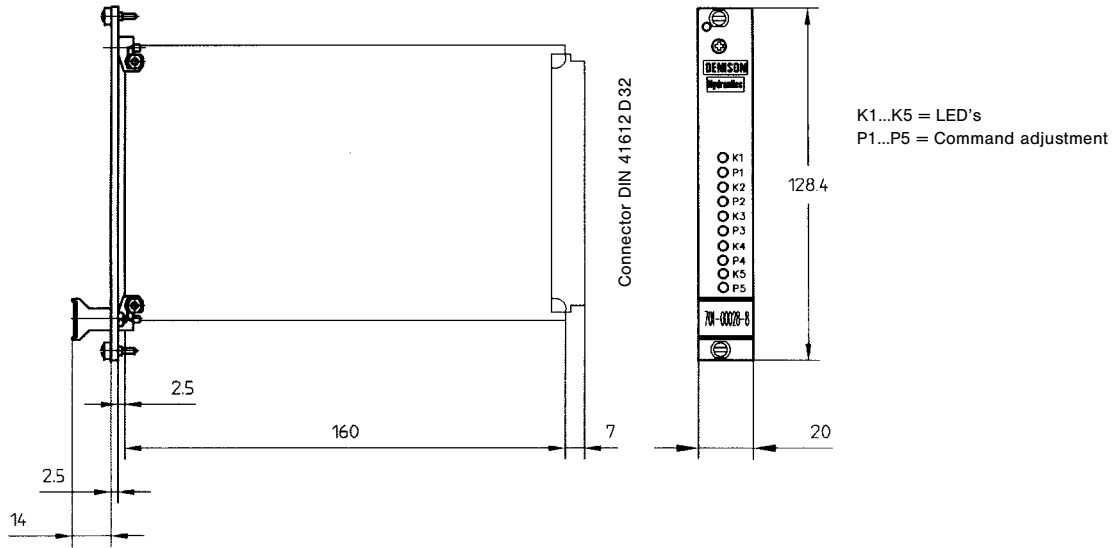

Schematic block diagram and terminal assignment

Proportional amplifier
(see page 9)

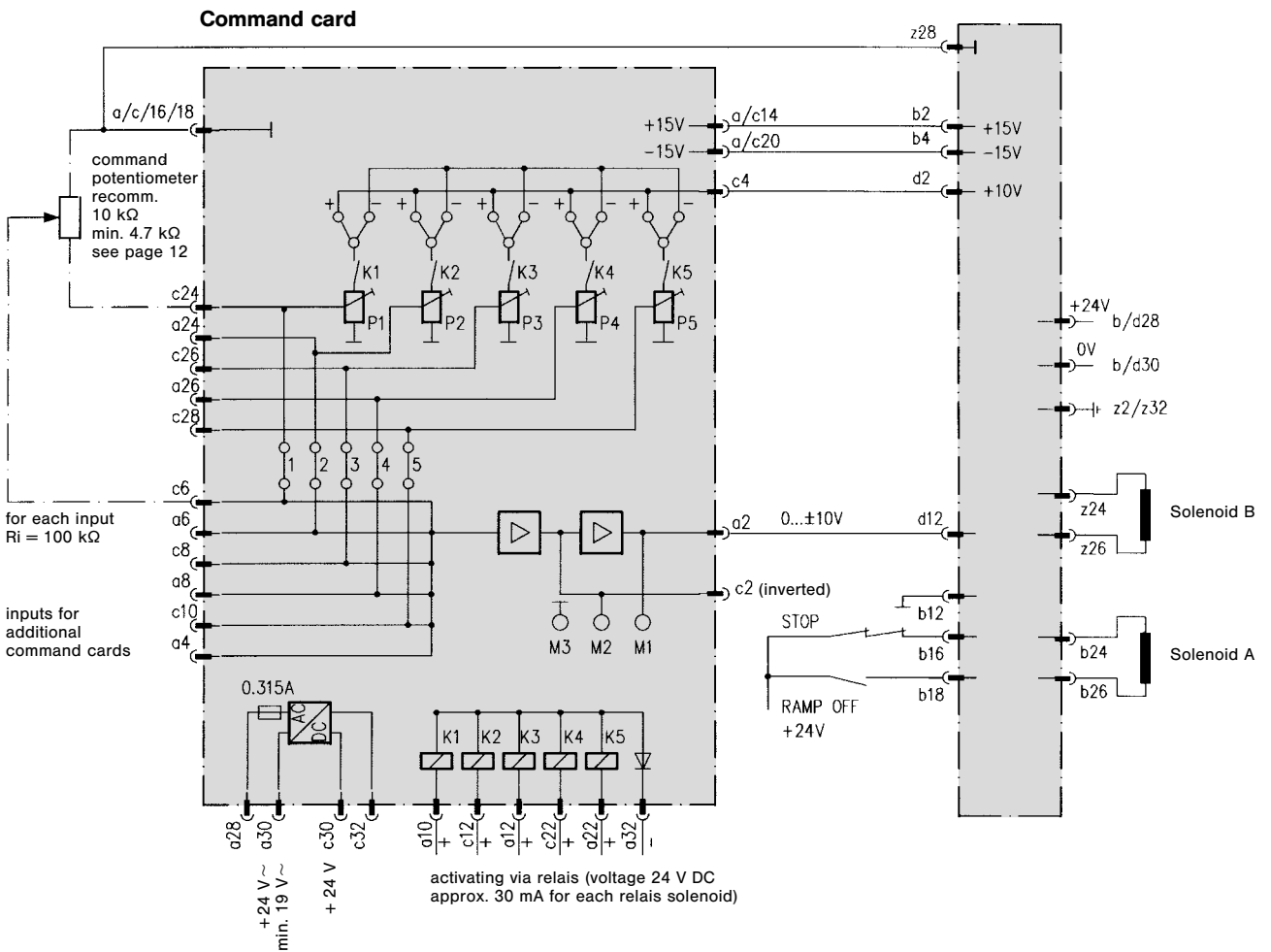

ACCESSORIES

Potentiometer-Adjusting knob
Order No. 701-00014-8

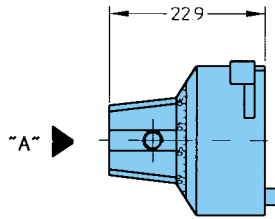
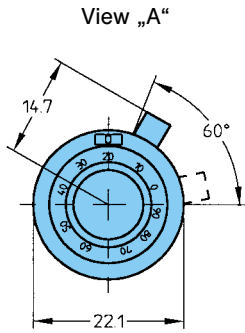

Potentiometer

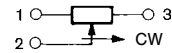
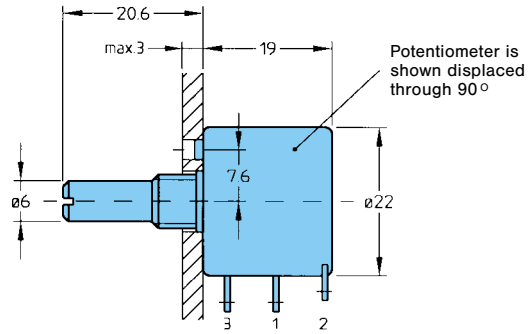

Adjusting knob with scale 0...100 and with revolution counter. Adjustment is lockable.

Panel opening

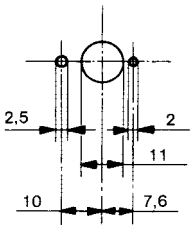

Potentiometer Characteristics	Potentiometer Order No.	
	701-00012-8	701-00013-8
Angle of rotation	360°	3600°
Linearity	± 0.5%	± 0.25%
Resolution-Drift	0.11% of 360°	0.02% of 3600°

Power supply
Order No. 701-00023-8
Weight: 0.25 kg

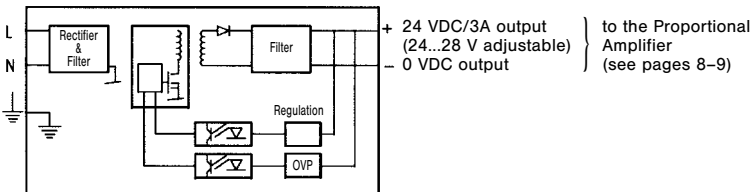
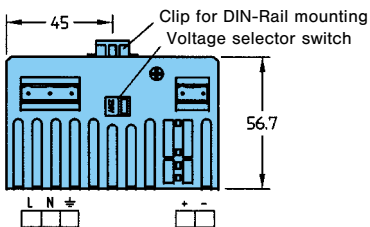
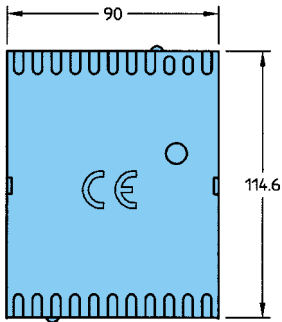

L = Nominal frequency 50/60 Hz
Nominal voltage 230 VAC or 115 VAC (pay attention to voltage selector switch setting)
N = Neutral line

Euro-Card-Holder

Order No. 701-00066-8
Holder for individual mounting according to DIN 41612, design F48

