 www.khadamathydraulic.com
Tell: 021-55882749
Tell: 021-33488178
Fax: 021-33488105

DENISON HYDRAULICS

Proportional Directional Valves Cetop 07

Series 4DP03-T

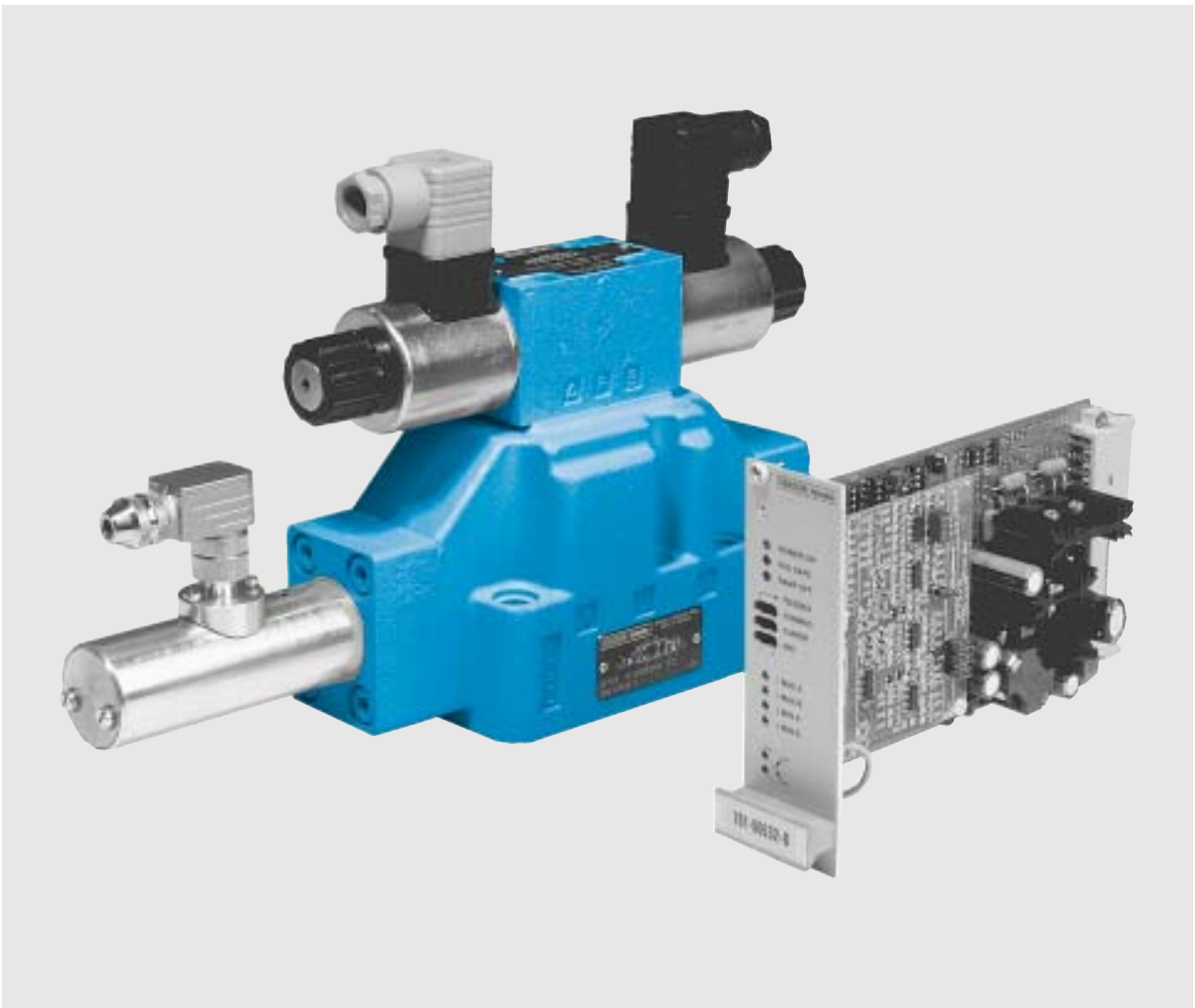

Publ. 4-EN 3610-B, replaces 4-EN 3610-A

DENISON Hydraulics

FEATURES, SYMBOL

FEATURES

- Infinite variable motion control provides optimum machine cycles.
- Effective flow control even in the low range of command signals.
- Largest spool size with 50 % flow path ratio for application with 2 : 1 differential cylinders.
- Reliable and insensitive to contamination due to robust design.
- High dynamic and precise function together with matched DENISON proportional amplifier.
- Electrical connection by standard plug-in connectors conform to ISO 4400.
- Screw-type feedback connector conform to EMC and to DIN / VDE 0660 part 208 A6.
- Valve mounting configuration conform to ISO 4401.
- Each valve is factory tested prior to delivery.
- Worldwide DENISON service.

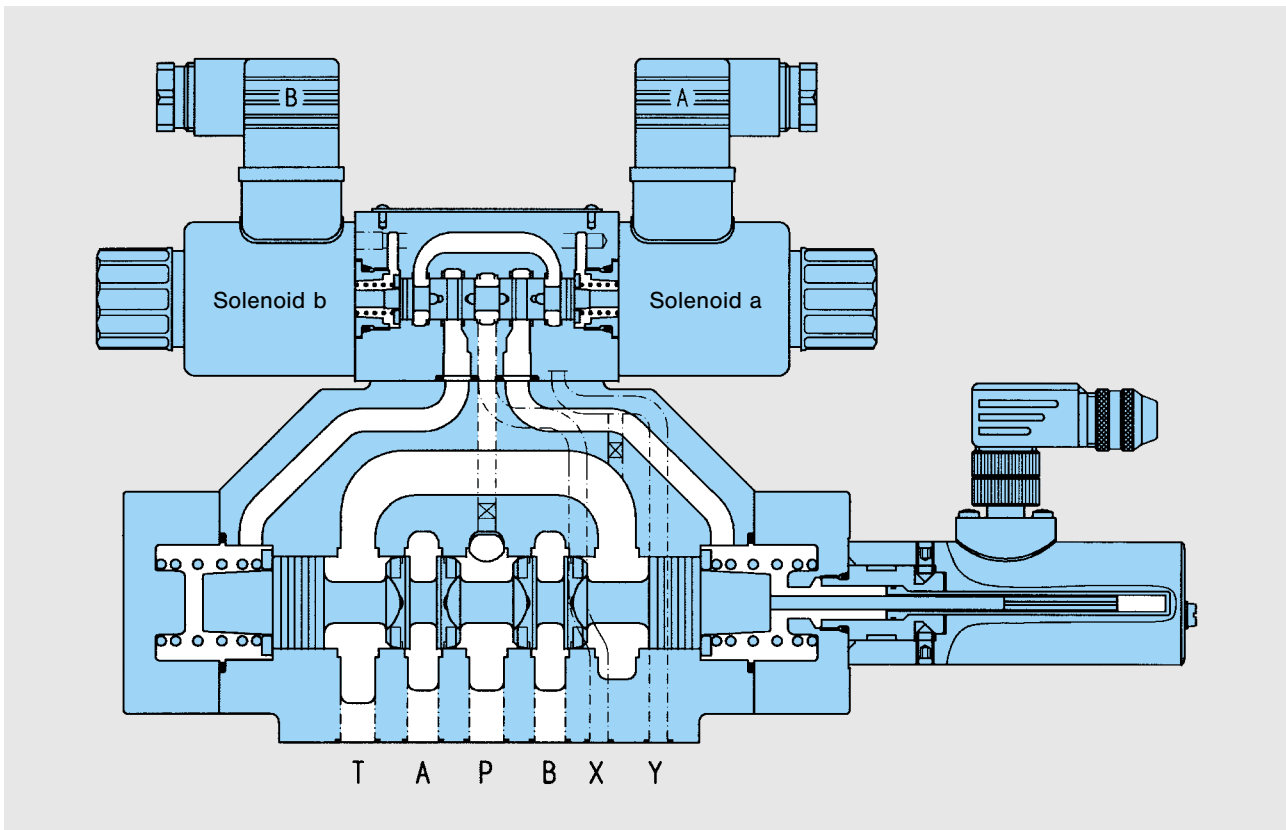

SYMBOL

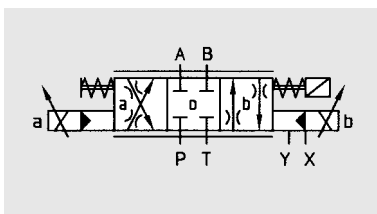

DESCRIPTION

GENERAL

Proportional valves with **integrated position feedback** are preferably used in hydraulic applications where low hysteresis, high repeatability and higher dynamics are required.

An electrical input signal via the proportional amplifier (set value) to the pilot valve, results in a hydraulic flow (actual output value) from the main stage.

PILOT STAGE

The main stage is controlled by a built-on open loop proportional directional valve with a standardised interface conform to ISO 4401.

PRESSURE REDUCING VALVE IN "X"

In cases where high variations in the system pressure are expected it is advisable to select the version with an integrated stackable reducing valve between pilot stage and the main stage (Option R1).

MAIN STAGE

The control spool of the main stage is provided with throttling notches and connected to a position feedback transducer (LVDT). The shape of the notches creates a defined flow, proportional to the input signal at a specific pressure drop of 5 bar across one spool edge (see graphs on page 6).

For 2 : 1 differential cylinder applications, "Q/2" spools are available and can be selected by using the spool type designation; "A" or "B" in the ordering code.

Deviations between **set value** and **actual value** caused by mechanical friction, hydraulic flow forces or variation in pressure are corrected by the interaction between the linear transducer and the dedicated optimised DENISON proportional amplifier.

PROPORTIONAL AMPLIFIER

Schematic block diagram, terminal assignment, accessories, set-up and adjustment instructions of the proportional amplifier are shown in this leaflet. All technical valve specifications presented for this valve, especially dynamic behaviour are only valid when used with the designated proportional amplifier.

TECHNICAL DATA

GENERAL AND HYDRAULIC CHARACTERISTICS

<ul style="list-style-type: none"> • Design • Mechanical overlap • Effective overlap / command • Mounting position • Type of mounting • Max. operating pressure stat. <ul style="list-style-type: none"> – at internal drain – at external drain • X-port • Flow • Nominal flow • Maximum flow recommended • Fluid temperature range • Ambient temperature range • Viscosity range • Hysteresis • Repeatability • Response time <ul style="list-style-type: none"> – step signal 0...100 % – step signal 100...0 % • Fluid • Contamination level 	<p>Sliding spool valve, proportional controlled with feedback transducer</p> <p>≈ 15 %</p> <p>10 %</p> <p>(with proportional amplifier 701-00632-8)</p> <p>Optional but horizontal recommended</p> <p>Subplate body according to ISO 4401</p> <table border="0" style="width: 100%;"> <tr> <td style="width: 33%;">P, A, B</td> <td style="width: 33%;">T</td> <td style="width: 33%;">Y</td> </tr> <tr> <td>350 bar</td> <td>210 bar</td> <td>210 bar</td> </tr> <tr> <td>350 bar</td> <td>350 bar</td> <td>210 bar</td> </tr> </table> <p>max. 350 bar</p> <p>Option R1 see page 3 (factory set 50 bar)</p> <p>see curves on page 6</p> <p>100 / 130 / 200 l/min</p> <p>(at $\Delta p = 5$ bar each spool edge)</p> <p>500 l/min (at double path application)</p> <p>– 18...+80 °C</p> <p>– 10...+50 °C</p> <p>10...650 cSt; optimal 30 cSt</p> <p>≤ 1 %</p> <p>≤ 0.5 %</p> <p>at 50 bar pilot pressure and $\Delta p = 5$ bar at each spool edge; 12 Volt solenoid.</p> <p>see curves on page 6</p> <p>see curves on page 6</p> <p>Petroleum base anti-wear fluids (covered by DENISON HF-0 and HF-2 specification). Such as mineral oil according to DIN 51524/25. Maximum catalogue ratings and performance data are based on operation with these fluids.</p> <p>Fluid must be cleaned before and continuously during operation by filters that maintain a cleanliness level of NAS 1638 Class 8 (Class 9 for 15 micron or smaller). This basically corresponds to ISO 17/14.</p> <p>Better cleanliness levels will significantly extend the life of the components. As contaminant entrainment and contaminant generation may vary with each application, each must be analysed to determine proper filtration to maintain the required cleanliness level.</p>	P, A, B	T	Y	350 bar	210 bar	210 bar	350 bar	350 bar	210 bar
P, A, B	T	Y								
350 bar	210 bar	210 bar								
350 bar	350 bar	210 bar								

ELECTRIC CHARACTERISTICS

<ul style="list-style-type: none"> • Type of voltage (DC) • Coil resistance <ul style="list-style-type: none"> – cold start 20 °C – warm value 50 °C • Nominal current • Max. current • Max. coil temperature (temperature class F) • Type of protection (DIN 40050) • Relative operating period 	<p>12 V</p> <p>3.7 Ω</p> <p>4.51 Ω</p> <p>2.2 A</p> <p>2.5 A</p> <p>+ 155 °C</p> <p>IP 65</p> <p>100 %</p>
--	--

TRANSDUCER CHARACTERISTICS

<ul style="list-style-type: none"> • Supply voltage U_s • Perm. ripple from I_{out} pp • Current consumption I_s • Output signal I_{out} • Sensitivity • Measuring stroke • Temperature drift 	<p>24 V DC ± 20 %</p> <p>< 0.04 mApp</p> <p>≤ 40 mA</p> <p>4...20 mA</p> <p>1.6 A/mm ± 3 %</p> <p>± 5 mm</p> <p>≤ ± 0.01 % from stroke / °C</p>
--	--

ORDERING CODE

Model Number:	4DP03	3	T	03	A	.	G12																		
	1	2	3	4	5	6	7	8	9	10	11	12	13																		
1 Series	03 = Cetop 07																														
2 Body	3 = Standard																														
3 Type of Control	T = Electro-hydraulic with position feedback																														
4 Spool Type	<table border="0" style="width: 100%; border-collapse: collapse;"> <tr> <td style="width: 5%;">02</td> <td style="width: 25%;"></td> <td style="width: 70%;">P→A; B→T or P→B; A→T = Q</td> </tr> <tr> <td>A2</td> <td></td> <td>P→A = 1/2 Q; B→T = Q or P→B = Q; A→T = 1/2 Q</td> </tr> <tr> <td>B2</td> <td></td> <td>P→A = Q; B→T = 1/2 Q or P→B = 1/2 Q; A→T = Q</td> </tr> <tr> <td>43</td> <td></td> <td>P→A; B→T or P→B; A→T = Q</td> </tr> <tr> <td>A3</td> <td></td> <td>P→A = 1/2 Q; B→T = Q or P→B = Q; A→T = 1/2 Q</td> </tr> <tr> <td>B3</td> <td></td> <td>P→A = Q; B→T = 1/2 Q or P→B = 1/2 Q; A→T = Q</td> </tr> </table>													02		P→A; B→T or P→B; A→T = Q	A2		P→A = 1/2 Q; B→T = Q or P→B = Q; A→T = 1/2 Q	B2		P→A = Q; B→T = 1/2 Q or P→B = 1/2 Q; A→T = Q	43		P→A; B→T or P→B; A→T = Q	A3		P→A = 1/2 Q; B→T = Q or P→B = Q; A→T = 1/2 Q	B3		P→A = Q; B→T = 1/2 Q or P→B = 1/2 Q; A→T = Q
02		P→A; B→T or P→B; A→T = Q																													
A2		P→A = 1/2 Q; B→T = Q or P→B = Q; A→T = 1/2 Q																													
B2		P→A = Q; B→T = 1/2 Q or P→B = 1/2 Q; A→T = Q																													
43		P→A; B→T or P→B; A→T = Q																													
A3		P→A = 1/2 Q; B→T = Q or P→B = Q; A→T = 1/2 Q																													
B3		P→A = Q; B→T = 1/2 Q or P→B = 1/2 Q; A→T = Q																													
5 Flow P→A; B→T or P→B; A→T	F100 = 100 l/min } not available for spools A2, A3, B2 and B3 F130 = 130 l/min } F200 = 200 l/min (at Δp = 5 bar per spool edge)																														
6 Spool Position	03 = 3 (a, o, b), spring centred, spool in "o"-position																														
7 Design Letter																															
8 Seal Class	1 = NBR (Buna N) Standard 5 = Viton®																														
9 Solenoid Voltage	G12 = 12 V DC																														
10 Electrical Connector	w/o code = connector not supplied C1 = connector PG 11 & PG 9																														
11 Main Valve – Pilot Connections	w/o code = X, Y external X = internal X, external Y Y = external X, internal Y XY = internal X, internal Y																														
12 Hydraulic Accessories	w/o code = w/o pressure reducing valve R1 = with pilot pressure reducing valve																														
13 Modifications	N0 = without manual override																														

CURVES

Step Response Time

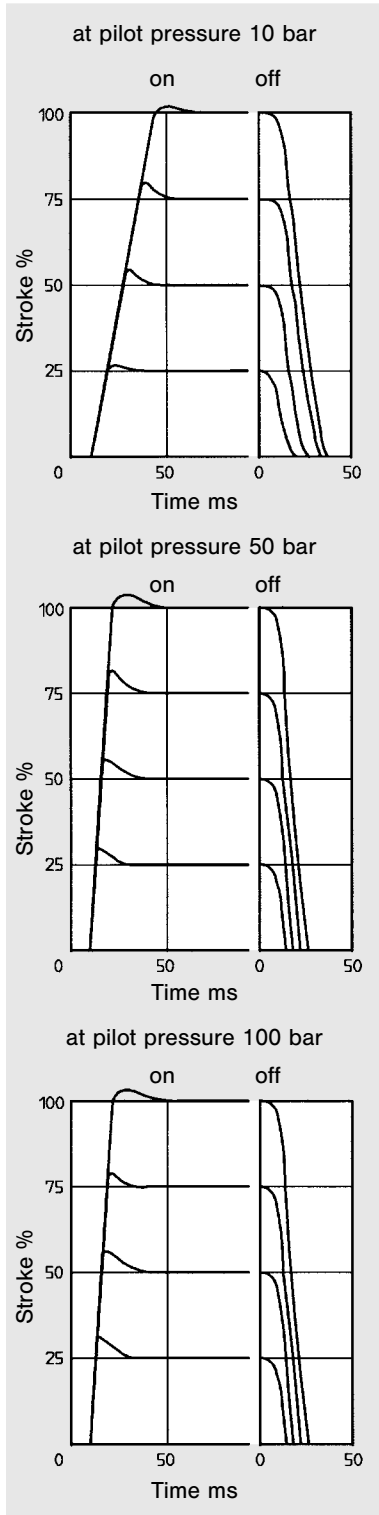

Flow versus Command Signal at $\Delta p = 5$ bar each spool edge

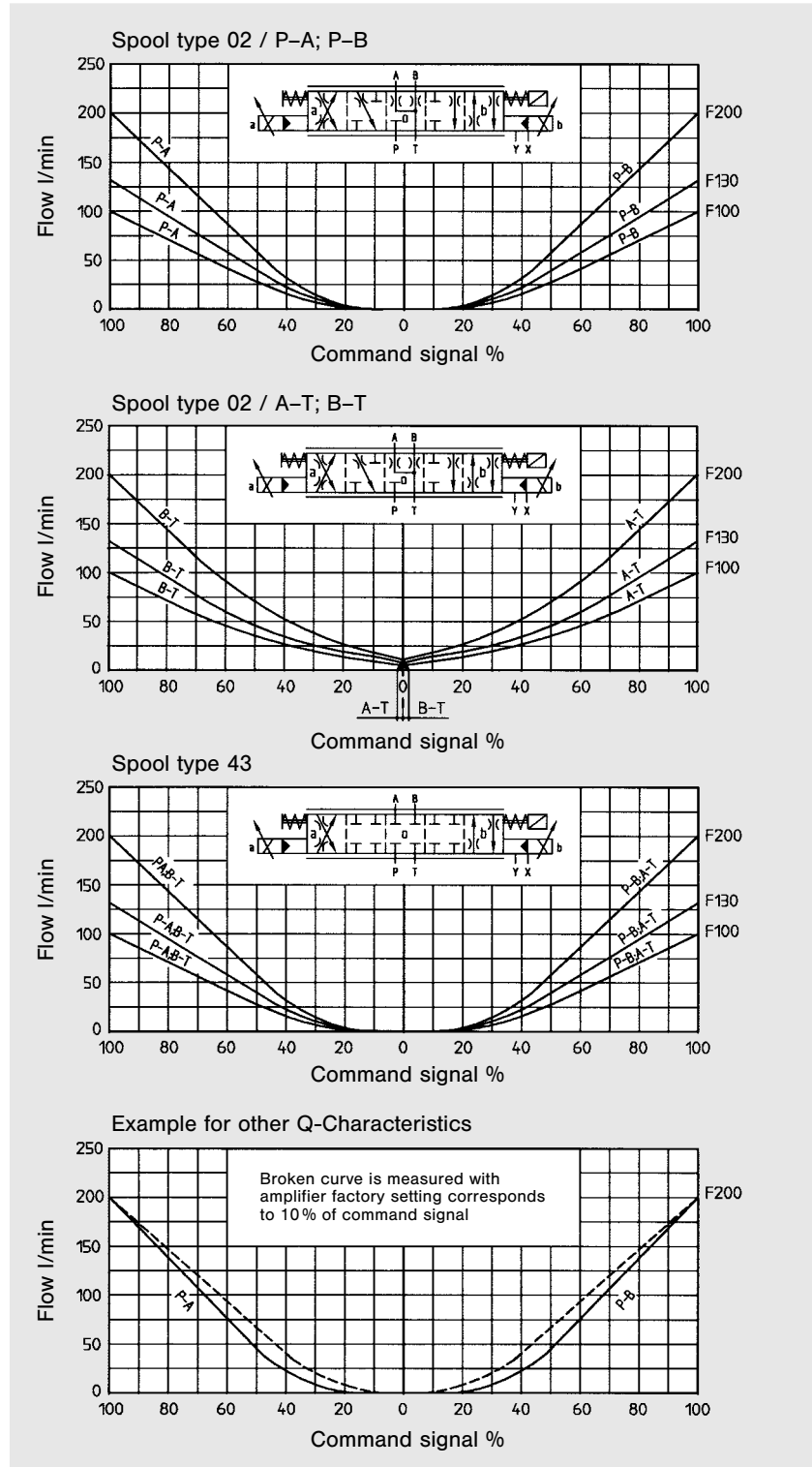

Note: Full line curves are measured with amplifier setting $I_{min} = 0$.

Nominal flow

Using other pressure drops the flow is changing as following:

$$Q_x = Q_N \cdot \sqrt{\frac{\Delta p_x}{5}}$$

DIMENSIONS, SYMBOLS

Weight: 11.0 kg

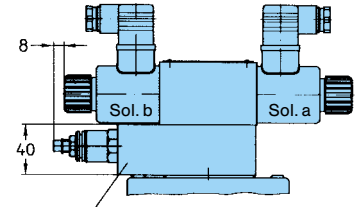
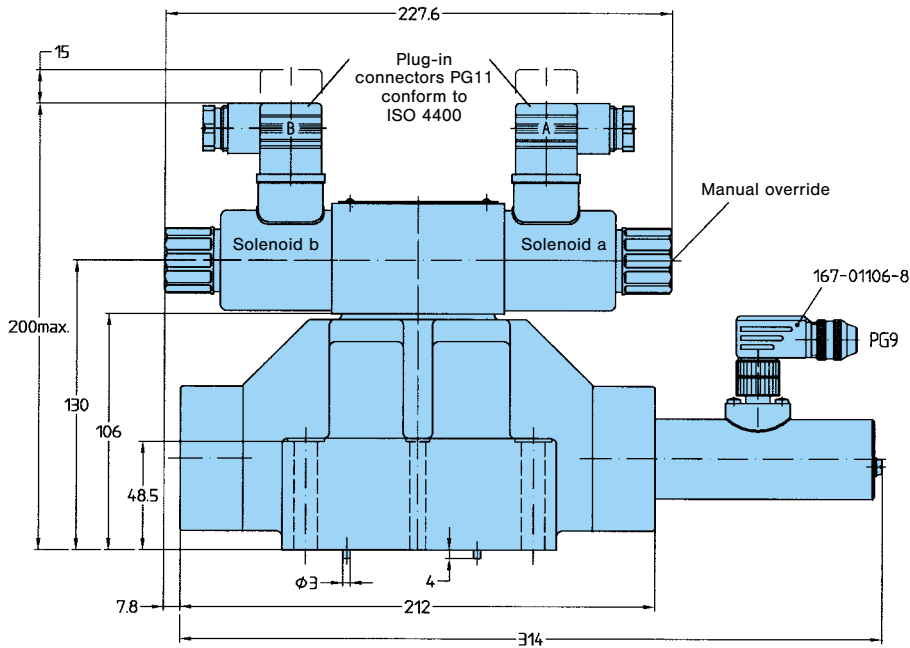

Pressure reducing valve Code R1
Weight: 1.6 kg

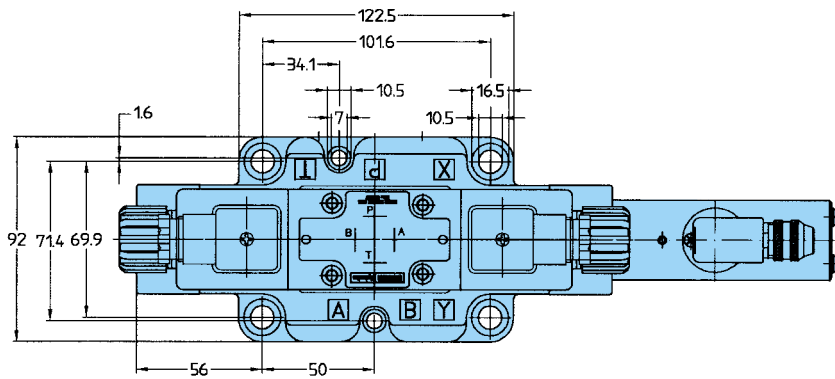

Symbol (detailed)
with pressure reducing valve R1

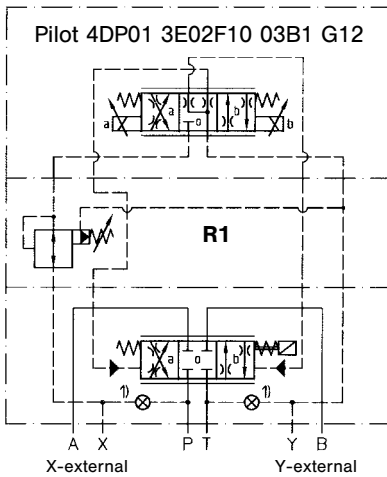

Symbol (simplified)

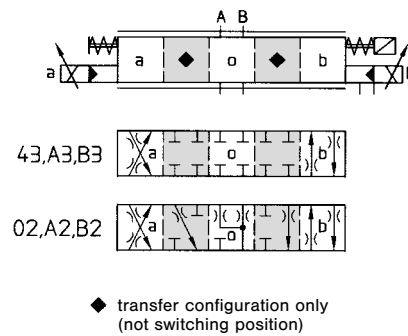

Electrical connection solenoids

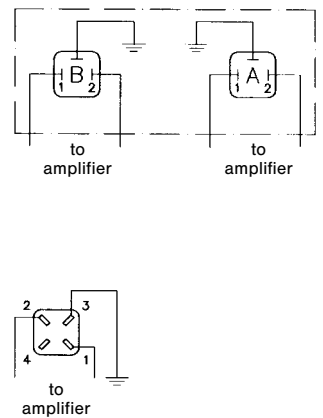

1) Plugs are mounted according to chosen pilot connections

PROPORTIONAL AMPLIFIERS WITH RAMPS

Order No.: 701-00632-8
Weight: 260 g



This proportional amplifier is designed to control pilot operated proportional directional valves with position feedback and 12 V solenoids. The amplifier proportionally convert electrical input signals into solenoid current. The transducer forms a position feedback circuit for the valve together with the PID regulator on the proportional amplifier. Differences between command and feedback signal are supplied as a corrective current to the proportional solenoid on the valve.

The amplifier has a reverse polarity protection and two short circuit protected PWM-output stages with max. current limit.

To operate this double solenoid proportional valve with the proportional amplifier the output stages for solenoid A must be fitted correctly with pin b24/b26 and for solenoid B with pin z24/z26.

The command signal input will be connected always to the same input line. The different kind of command signals will be set by DIP-switches on the main board. Potentiometers at the front panel are intended for the adjustment of ramp circuits up/down (independently from each other), max. flow (I_{max}) and min. flow (I_{min}). The zero-point adjustment enables the positive overlap of the spool, typical of proportional valves, to be bypassed. The electrical zero-point (I_{min}) can be adjusted to 0...50% of I_{max} .

By changing the input signal from 0...2% of max. command signal, the amplifier passes over to the "Imin-leap"-function (dead-band elimination).

There are diagnostic LED's to display the working condition (POWER ON), ramp function (RAMP OFF) and "FAIL SAFE" in case of short circuit or external STOP of the card. Test sockets are provided at the front panel to measure the actual solenoid current as well as the command voltage or the transducer feedback signal (see drawing).

Characteristics – Proportional Amplifier

- Supply voltage
 - nominal 24 V DC
 - smoothed battery voltage 20...32 V DC
- Reference voltage
 - ± 15 V ($\pm 5\%$) @ 50 mA from amplifier to external supply
 - ± 10 V ($\pm 0.5\%$) @ 10 mA stabilised from amplifier to command potentiometer
 - $I_{nom} = 2.2$ A @ 100% command signal
- Solenoid nominal current
- Current consumption max.
 - 12 V solenoid < 3 A
- Short circuit protection for solenoid
- Input signals

	2 Solenoids	Input impedance
1.	$-20...0...+20$ mA = $-100...0...+100\%$	100 Ω
2.	$+4...+20$ mA = $-100...0...+100\%$	100 Ω
3.	$-5...0...+5$ V = $-100...0...+100\%$	100 k Ω
4.	$-10...0...+10$ V = $-100...0...+100\%$	200 k Ω
5.	customised selectable; R83 = 20 k Ω /V x VCOMMAND	Value determined by R83

- Outputs
- External stop (nom. 24 V)
 - (+) = solenoid A, (-) = solenoid B
 - illuminates on "FAIL SAFE", implement as NC (normally closed circuit) connection with an input voltage of 4 V...32 V; input impedance 3.3 k Ω
 - illuminates when "RAMP OFF", implement as NO (normally open circuit) connection with an input voltage of 4 V...32 V; input impedance 3.3 k Ω
- Ramp off (nom. 24 V)
- Potentiometer for
 - max. flow (I_{max} A, B) ...2.2 A
 - min. flow (I_{min} A, B) 0...50% of I_{max} ; factory set 10%
 - ramp up 0.2...10 s $\pm 20\%$ (1...50 V/s)
 - ramp down 0.2...10 s $\pm 20\%$ (1...50 V/s)
- Dither frequency selectable by DIP-switch (250 Hz factory set)
- Test socket
 - solenoid current 1 V \cong 1 A $\pm 5\%$
 - command voltage approx. 0... ± 10 V at 100% command signal (depends on I_{min} , I_{max} adjustment)
 - feedback signal 4 mA transducer signal $\cong -5$ V
 - 20 mA transducer signal $\cong +5$ V

PROPORTIONAL AMPLIFIERS WITH RAMPS

Dimensions Plug-in module 3U/8HP according to IEC 297

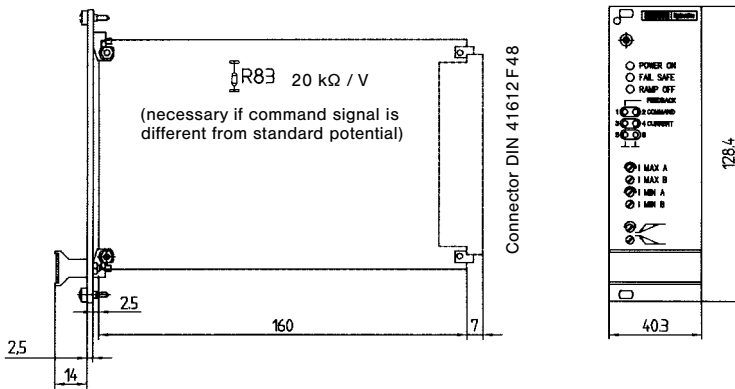

The output stages are short circuit protected. Short circuits at the outputs and supply input voltage falling below 20.5 V will result in the shutdown of the output stages, causing the "Fail Safe" LED come on. In this event, the supply voltage to the proportional amplifier must be switched off for a period of about 10 seconds.

Details on the front panel

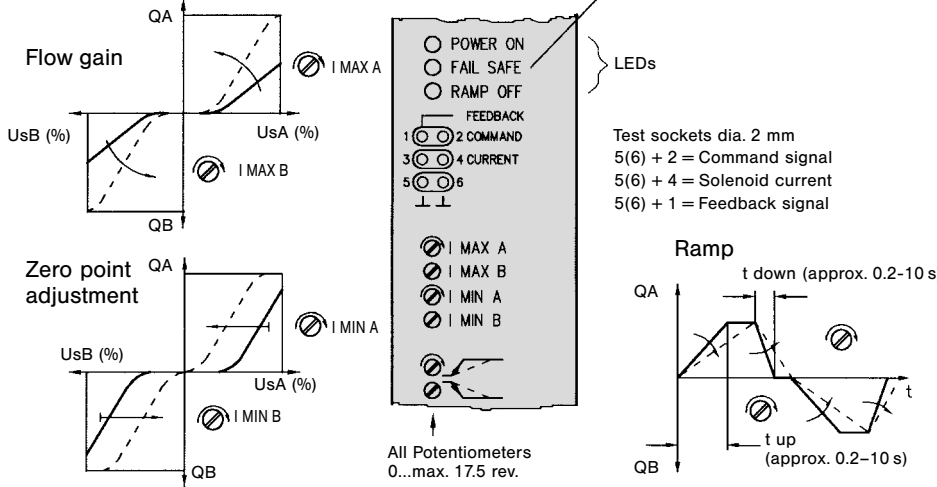

Schematic block diagram and terminal assignment

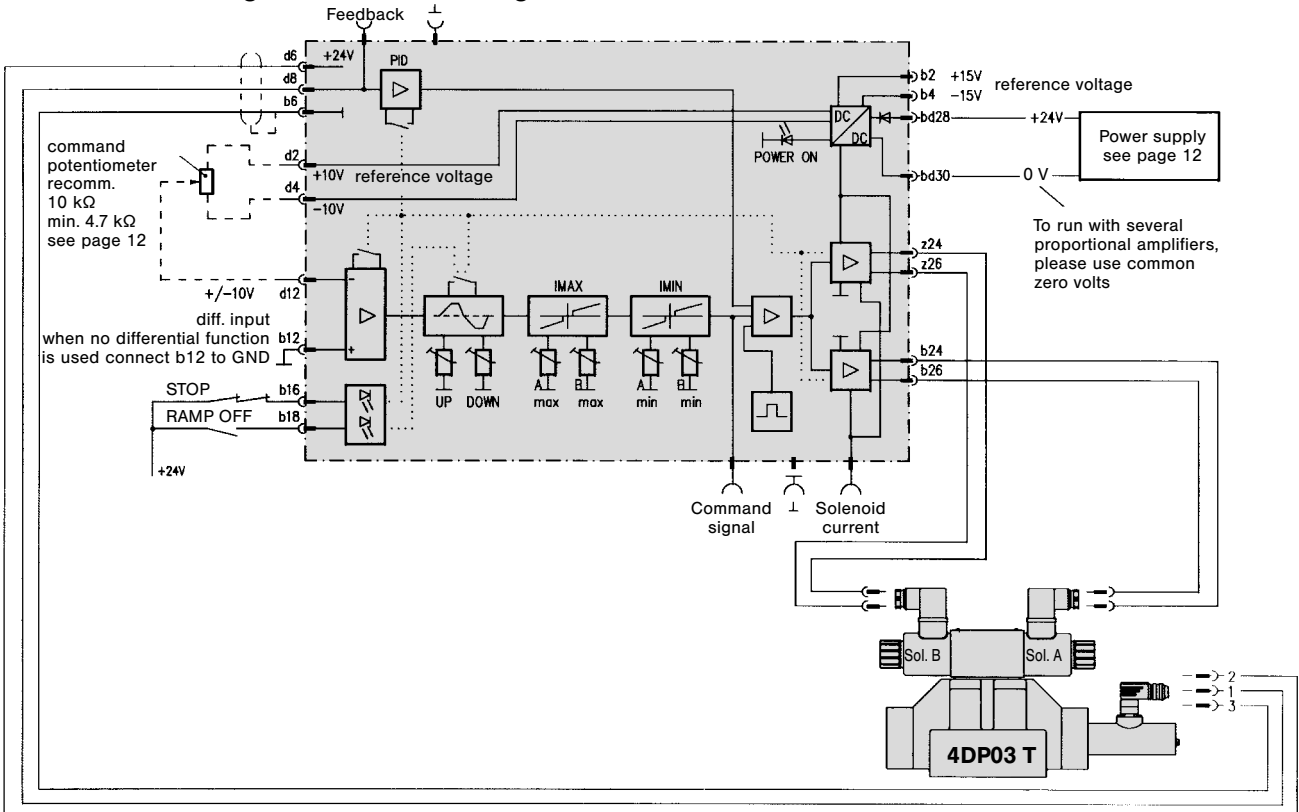

COMMAND CARD FIVE CHANNEL

Order No.: 701-00028-8
Weight: 150 g



This command card is designed to interface with all proportional amplifiers for DENISON proportional valves.

Five multiturn-potentiometers (P1...P5) allow different command signals. Selection is made by external energizing of the five selector relays on the command card.

By moving the solder bridges (+/-) it is possible to preset positive or negative commands for the desired level and direction.

In addition, the command card has a summing amplifier which enables the monitoring of the internal commands (solder bridges 1...5), or additional external resistor array.

These inputs (e.g. a 4) also make it possible to cascade further command cards if required.

The output signal to the proportional amplifier is available "not inverted" (a 2) and "inverted" (c 2).

The command card has a power rectifier with a 24 V DC output (input 24 V AC). Via this output c 30/32, the command relays can be energized.

All potentiometers are adjustable on the front panel.

The operating status of the corresponding command is indicated by an LED display on the front pannel (K1...K5).

LED on = Command level selected.

Characteristics – Command Card

- | | |
|--|--|
| • Supply voltage: | |
| – command card | supply from proportional amplifier |
| – rectifier | 24 V AC (min. 19 V AC) |
| • Command potentiometer | 5 potentiometers 0... 10 V |
| • Command relays | 5 potential – free contacts |
| • Relay contacts: | |
| – max. current on contact (resistive load) | 100 mA |
| – max. switching voltage | 30 V |
| – coil voltage | 24 V DC, approx. 30 mA incl. LED-display |

Euro-Card-Holder

Order No. 701-00007-8
Holder for individual mounting according to DIN 41612 design D32

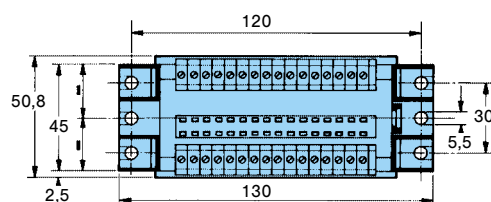
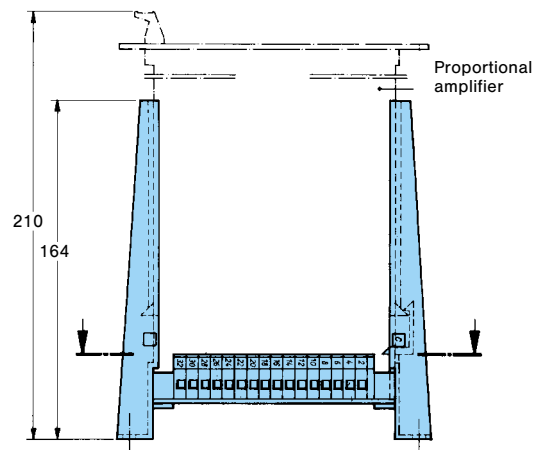

COMMAND CARD FIVE CHANNEL

Dimensions Plug-in module 3U/4HP according to IEC 297

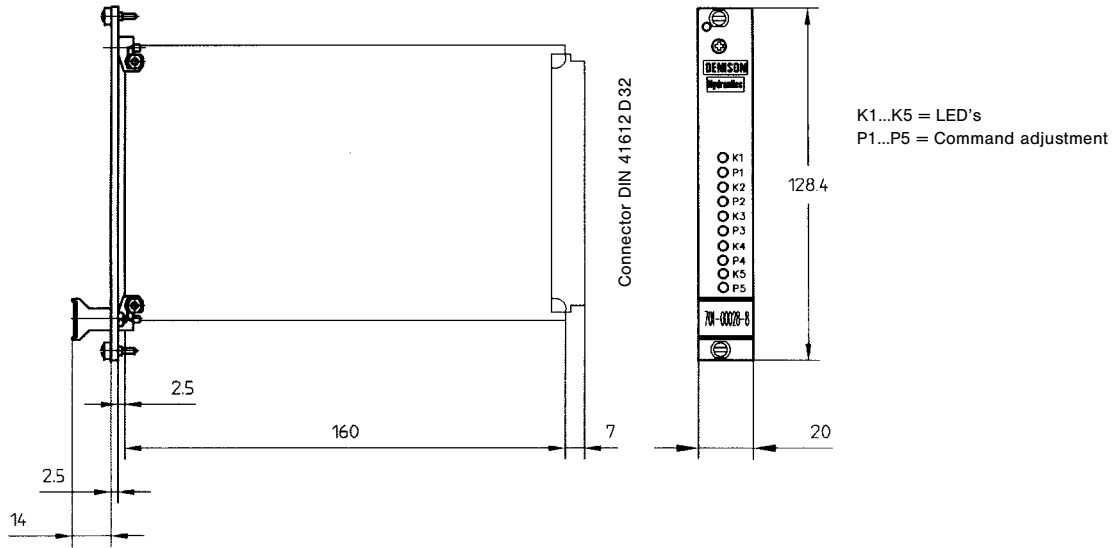

Schematic block diagram and terminal assignment

Proportional amplifier
(see page 9)

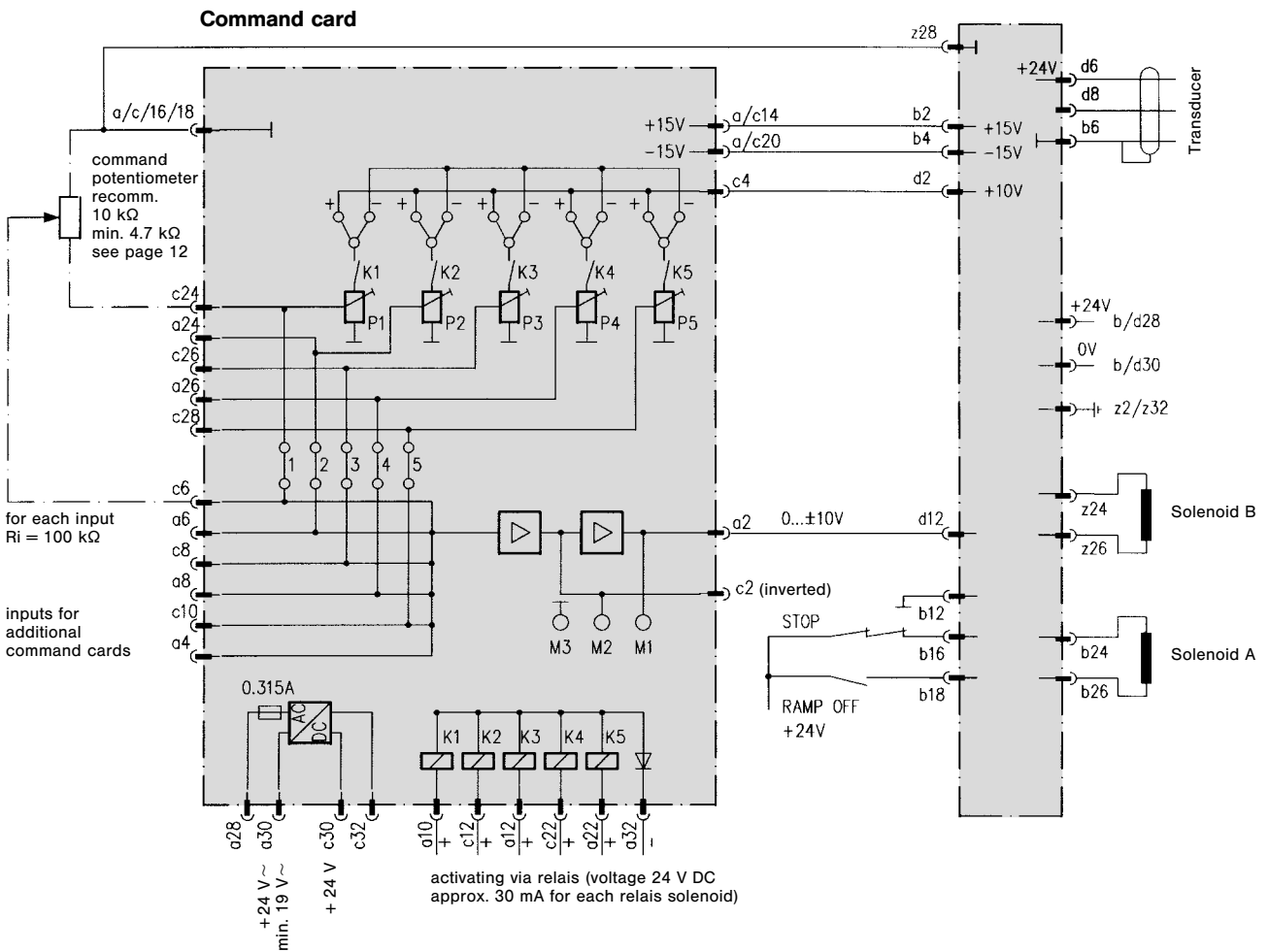

ACCESSORIES

Potentiometer-Adjusting knob
Order No. 701-00014-8

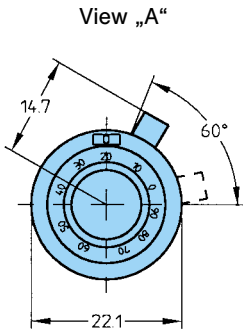

View "A"

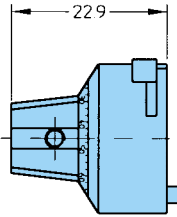

Potentiometer

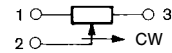
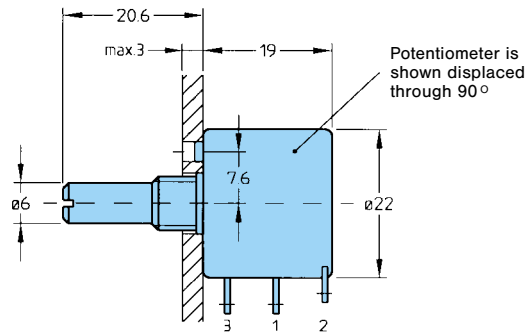

Adjusting knob with scale 0...100 and with revolution counter. Adjustment is lockable.

Panel opening

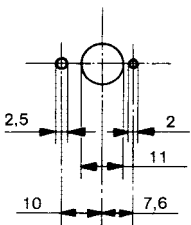

Potentiometer Characteristics	Potentiometer Order No.	
	701-00012-8	701-00013-8
Angle of rotation	360°	3600°
Linearity	± 0.5%	± 0.25%
Resolution-Drift	0.11% of 360°	0.02% of 3600°

Power supply
Order No. 701-00023-8
Weight: 0.25 kg

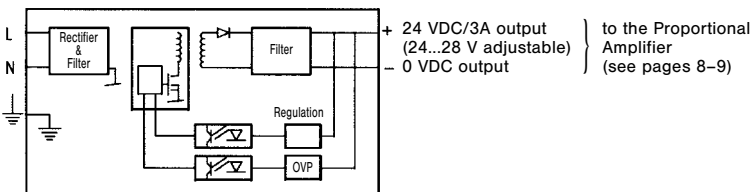
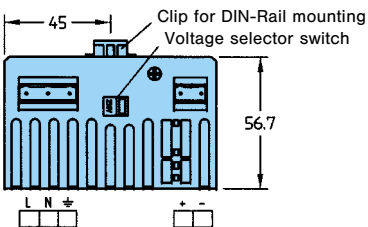
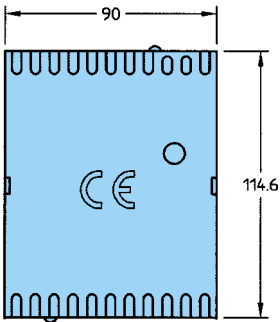

L = Nominal frequency 50/60 Hz
Nominal voltage 230 VAC or 115 VAC (pay attention to voltage selector switch setting)
N = Neutral line

Euro-Card-Holder

Order No. 701-00066-8
Holder for individual mounting according to DIN 41612, design F 48

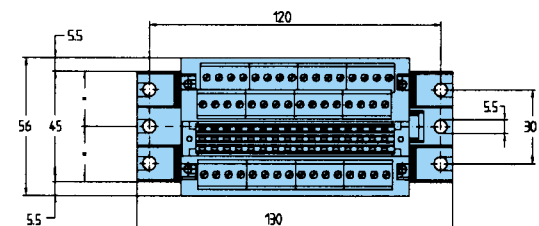
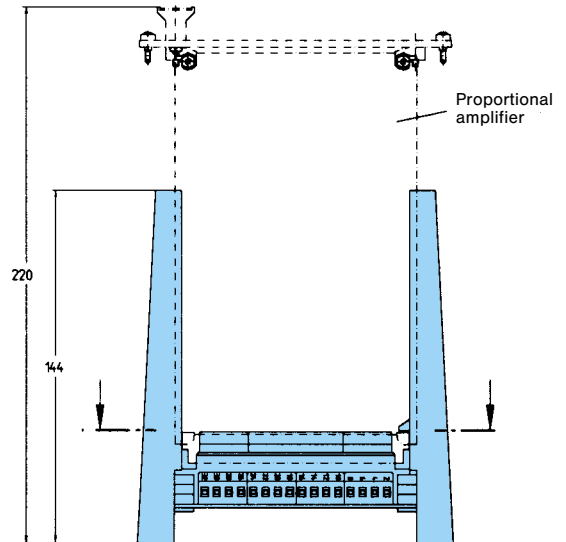

MOUNTING CONFIGURATION & SUBPLATE

Mounting Configuration conform to ISO 4401

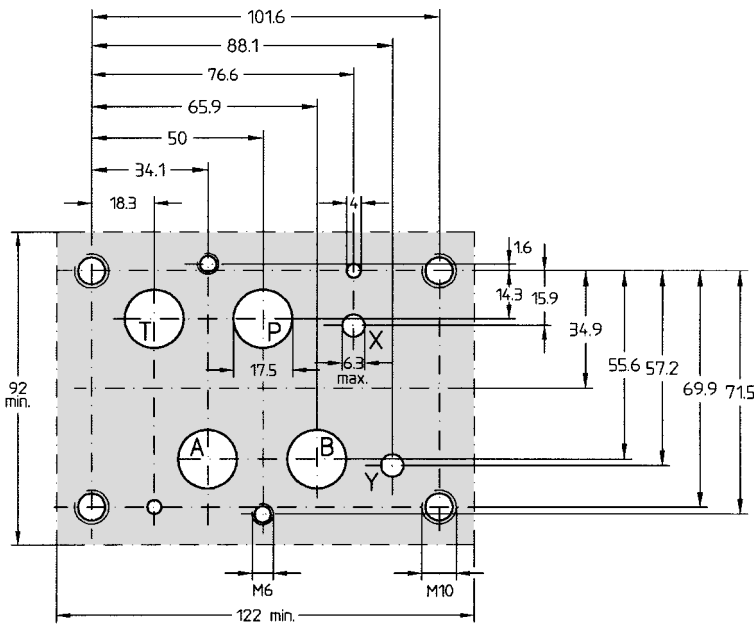

Block mounting face

Flatness 0.01 mm / 100 mm length

Surface finish $\sqrt{0.8}$

Port function

P = Pressure port

A & B = Working ports

T = Tank

X = ext. pilot port

Y = ext. drain port

NBR-Seals

A, B, T	21.89 x 2.62	691-00118-0
P	23.47 x 2.62	691-00119-0
X, Y	10.82 x 1.78	691-00013-0

Subplate (mount. configuration conform to ISO 4401)

Weight: \approx 8.3 kg

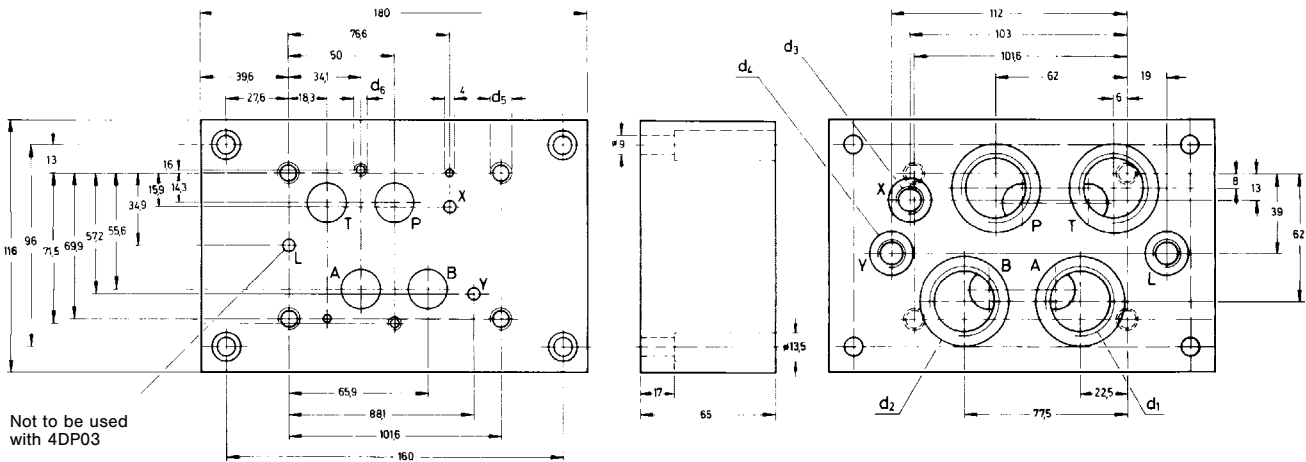

Not to be used with 4DP03

Mounting screws	Order-No.
(4) M 10 x 65 DIN 912; 10.9	700-71449-8
(2) M 6 x 60 DIN 912; 10.9	700-70806-8

Please note:

Mounting screws are included in subplate order.
For valves ordered without subplate, mounting screws must be ordered separately.

Torque 50 Nm for M10
13 Nm for M6

Model-No.	Order-No.	d ₁ (A, B, P, T)	d ₂	d ₃ (X, Y)	d ₄	d ₅	d ₆
SS-B-16-G 123-L	S26-58611-0	G 1"	47; 0.8 dp.	G 1/4"	23; 0.8 dp.	M 10	M 6

The product described is subject to continual development and the manufacturer reserves the right to change the specifications without notice.