 www.khadamathydraulic.com
Tell: 021-55882749
Tell: 021-33488178
Fax: 021-33488105

DENISON HYDRAULICS

Proportional Pressure Control Valves

Series P2 & 4VP01

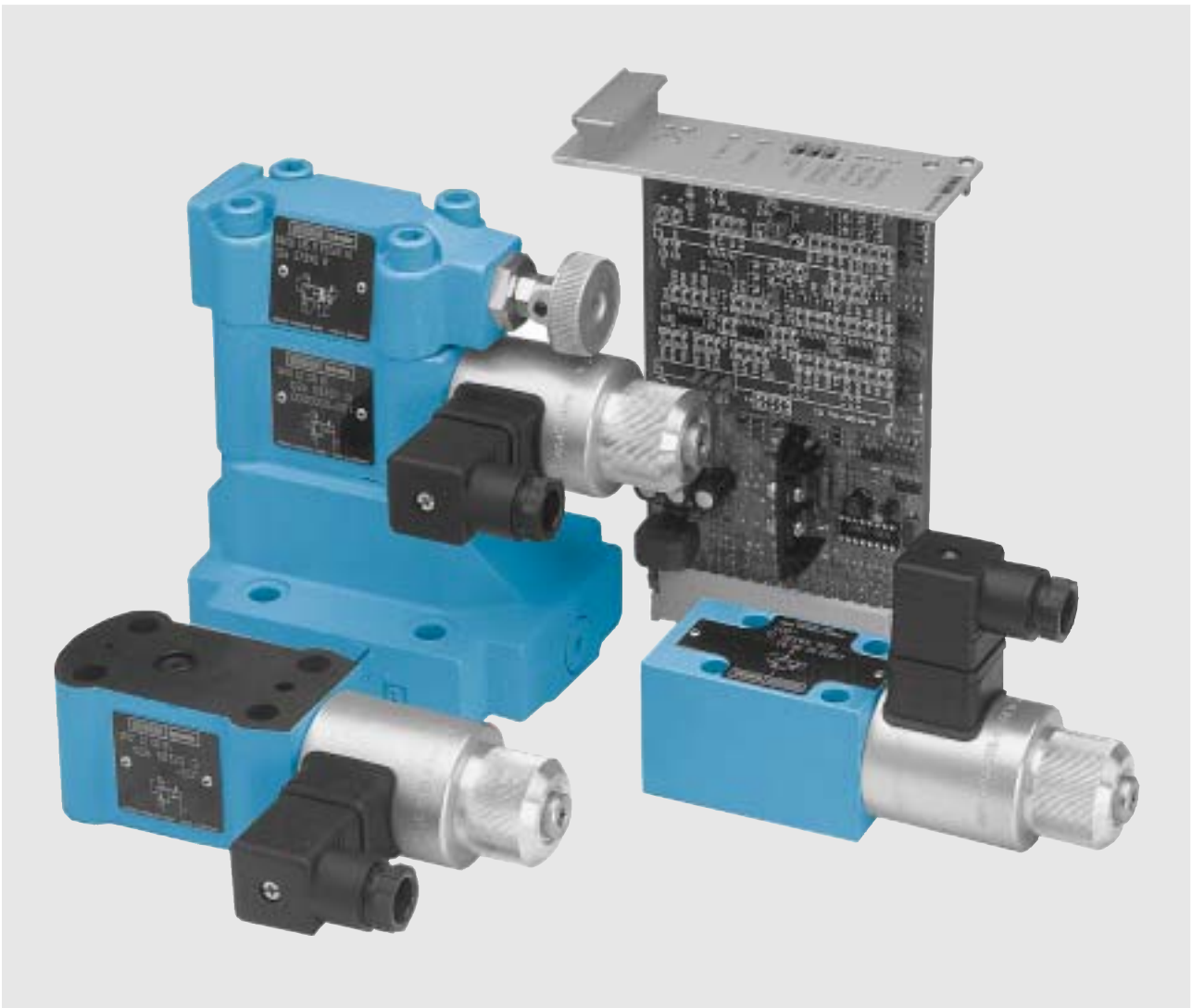

Publ. 3-EN 2200-B (dig.)

DENISON Hydraulics

FEATURES, SYMBOLES

FEATURES

- Electrical proportional adjustment of operating pressure in hydraulic systems.
- Ideal as directly operated valve for low flow up to 5 l/min, as pilot valve for pressure main stages and as pilot valve for pressure controlled pumps.
- Directly operated by an easy adjustable proportional solenoid.
- Design allows very low minimum pressure (see p_{min}/Q curve on page 4).
- Extremely low hysteresis $\pm 1.5\%$, repeatability $< 1.0\%$, high dynamic.
- Four pressure ranges available for high resolution operation: up to 50 / 105 / 210 / 350 bar.
- Mounting configurations:
 - As sandwich version (P2), for installation on DENISON pressure valve series R4 and R5 between the main stage and the manually adjustable pilot stage.
 - As subplate version (4VP01), conforming to ISO, CETOP 03.
- Proportional amplifier as rack mount Eurocard 3U, conforming to IEC 297.
- Valve and electronics from one supplier ensures optimal performance.

SYMBOL R4V...P2

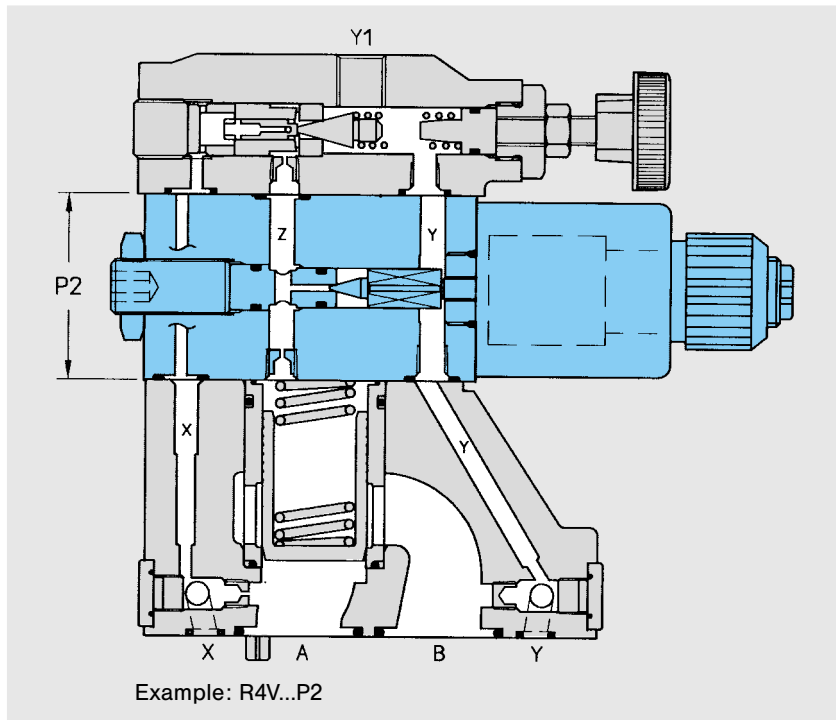
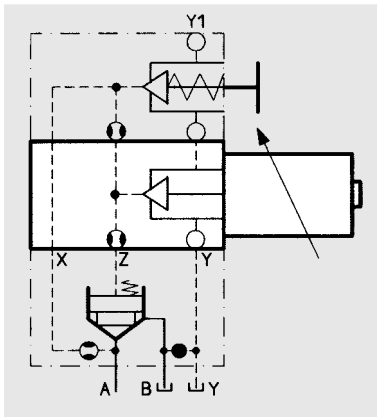

SYMBOL 4VP01

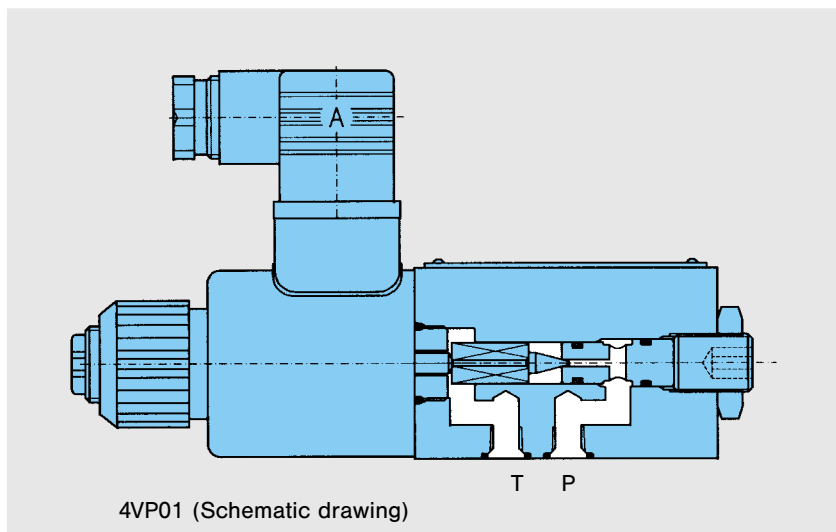
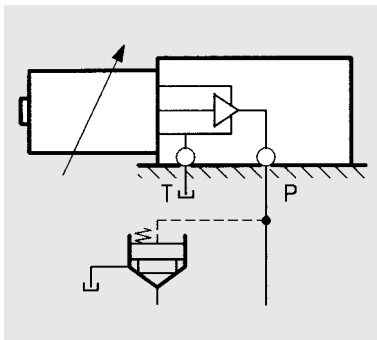

DESCRIPTION, TECHNICAL DATA

DESCRIPTION

The proportional pressure relief valve, series P2 and 4VP01, are directly operated by proportional solenoid.

The electrical input to the solenoid produces a corresponding holding force on the valve cone. If the pressure in the working port exceeds the holding force, the proportional cone is lifted from its seat, releasing flow to tank. This maintains the pressure in the working port proportional to the electrical input to the solenoid. The working port for series P2 valves is Port Z, that for series 4VP01, Port P.

The series P2 is provided as compact design, which can be mounted between the pilot valve and main body of the DENISON R4 and R5 range of valves.

In this case, the manually adjustable pilot stage determines the pressure ceiling, and should be set approximately 10 % higher than the maximum setting produced by the proportional section.

The pilot drain port must be connected to a stable low pressure tank line. Pressure variations in the drain port should be avoided.

TECHNICAL DATA

GENERAL

- Mounting position Horizontal mounting preferred, or vertical with the prop. solenoid at underside
- Direction of flow P2: Z→Y
4VP01: P→T
- Ambient temperature range -20 °C... +50 °C

HYDRAULIC CHARACTERISTICS

- Max. operating pressure 350 / 210 / 105 / 50 bar
- Min. operating pressure see curves on page 4
- Max. pressure on port T, Y or Y1 30 bar
- Nominal flow 5 l/min
- Fluid temperature -20 °C... +80 °C
- Fluid viscosity 10 cSt... 650 cSt
- Recommended viscosity 30 cSt
- Linearity 2.8%
- Hysteresis ± 1.5%
- Fluid Confirming to DIN 51524 and 51525
- Filter Pre-filter 280 µm; fine-filter 50 µm
- Contamination level Max. permissible contamination level according to NAS 1638 Class 8 (Class 9 for 15 micron and smaller) or ISO 17/14

ELECTRIC CHARACTERISTICS

- Type of current Direct current
- Min. current 300 mA
- Max. current 2500 mA
800 mA (for replacement of P1 valve)
- Dither frequency 270 Hz (recommended)
- Dither amplitude 120 mA (recommended)
- Coil resistance 4 Ω
25 Ω (for replacement of P1 valve)
- Type of protection IP 65
- Relative operating period 100 %
- Electrical connection Plug-in connector to ISO 4400

CURVES

p-U-CURVES

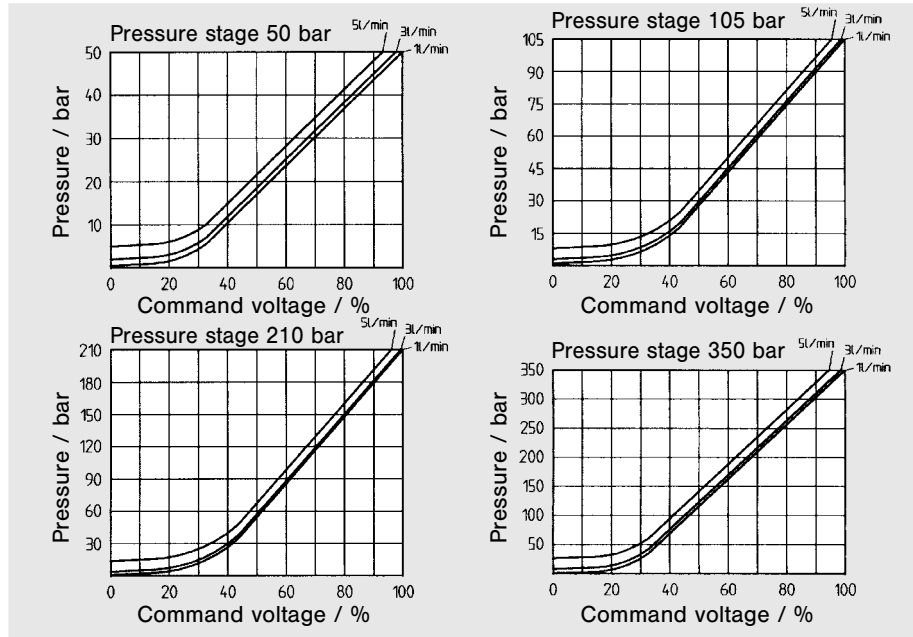

p-Q-CURVES

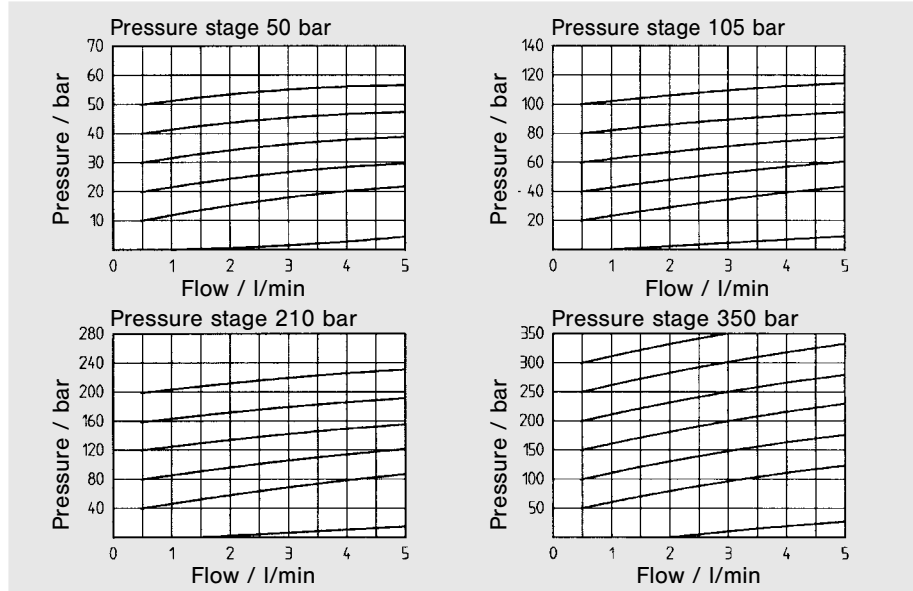

pmin-Q-CURVES

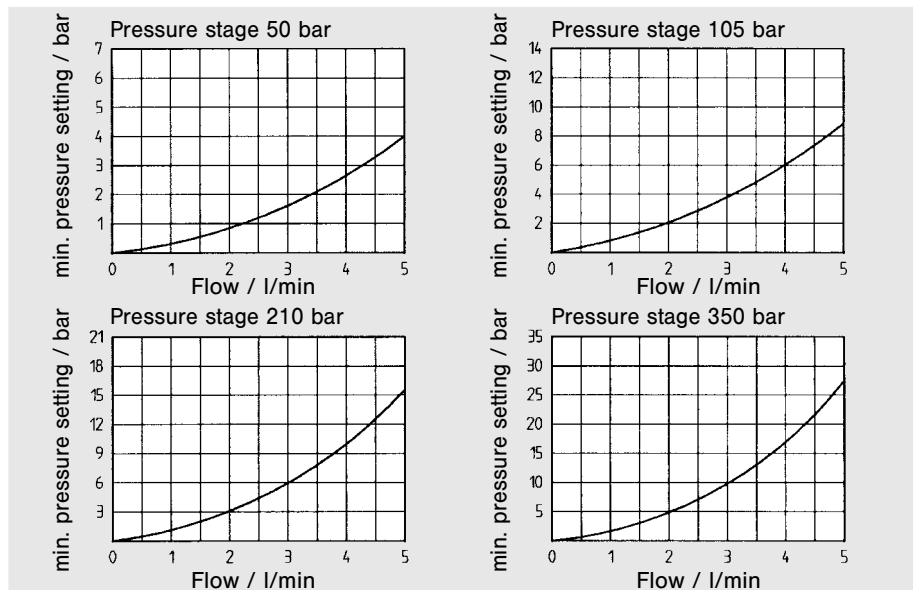

PROPORTIONAL PRESSURE CONTROL VALVE SERIES P2

Screws for additional proportional section installation
 4 off 3/8"-24 UNF x 3 1/2" lg., Order No. 359-15340-0.

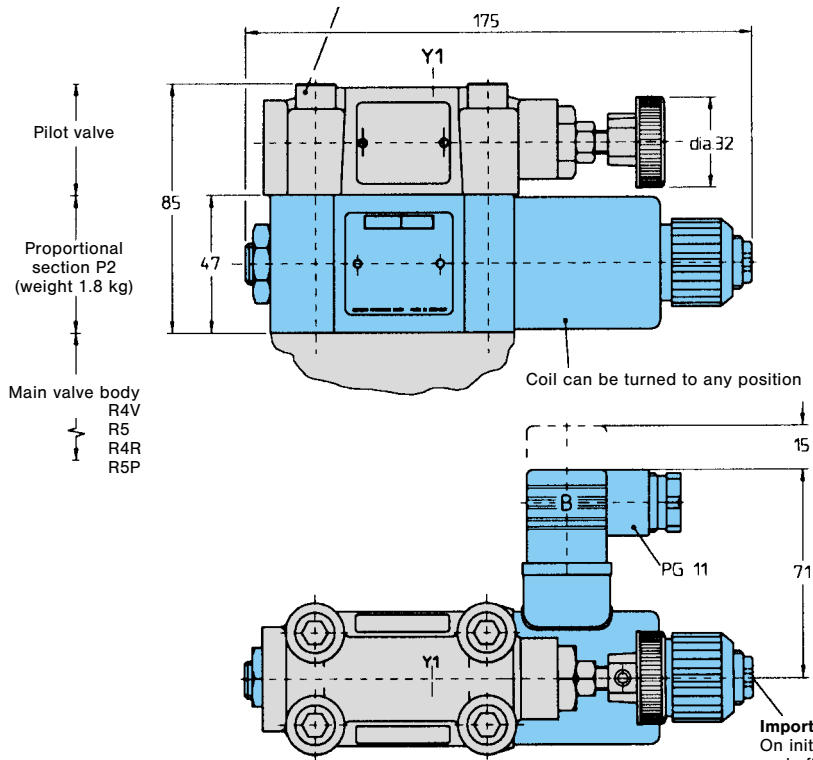

Drain Line:

- a) only external from the pilot head Y1, to a stable low pressure tank line (for threaded or flange main line)
- b) external from the pilot head Y1, or from the subplate Y, to a stable low pressure tank line, (for subplate mounted main stage)

Distance required to remove plug-in connector. Plug-in connector supplied as standard.

Important:
 On initial start up and after long shut down periods bleed air from this plug

When applying the proportional section P2 to an existing application please consult your local DENISON office.

For series R4V, R5V & R5P

Order No.	Pressure range
S26-58347-G	... 50 bar
S26-58348-G	... 105 bar
S26-58349-G	... 210 bar
S26-58350-G	... 350 bar

For series R4R & R5R

Order No.	Pressure range
S26-58376-G	... 50 bar
S26-58377-G	... 105 bar
S26-58378-G	... 210 bar
S26-58379-G	... 350 bar

Ordering Code for pilot operated Proportional Pressure Controls and Compensators

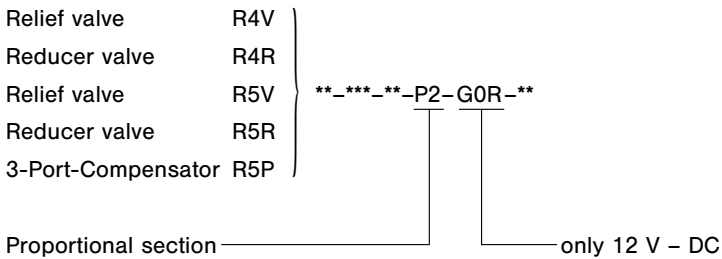

Note: For details of pilot operated pressure control valves and compensators with which this proportional section can be combined, please refer to following bulletins:

- 3-EN 2400: (R4V)
- 3-EN 2700: (R4R)
- 3-EN 2850: (R5V, R5R - Flanged type, 2 Ports)
- 3-EN 2900: (R5V - Flanged type, 3 Ports)
- 5-EN 4200: (R5P)

PROPORTIONAL PRESSURE CONTROL VALVE SERIES 4VP01

Weight: 1.8 kg

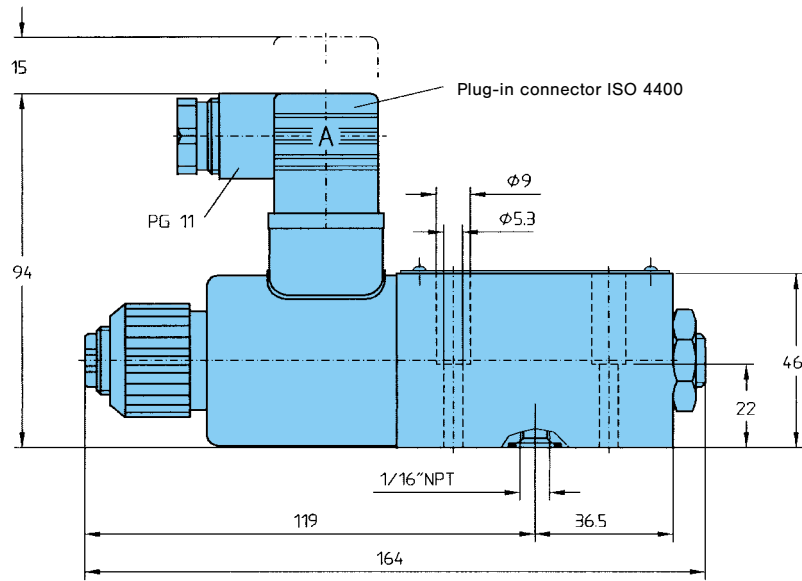

Important:
On initial start up
and after long shut down periods
bleed air from this plug

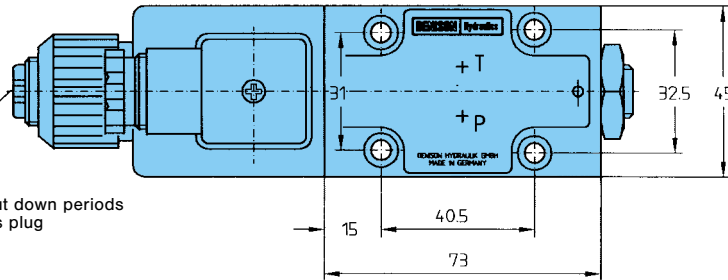

Version with max. pressure adjustment

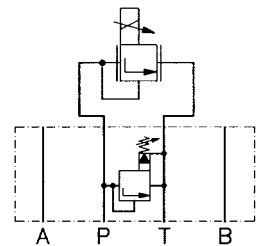
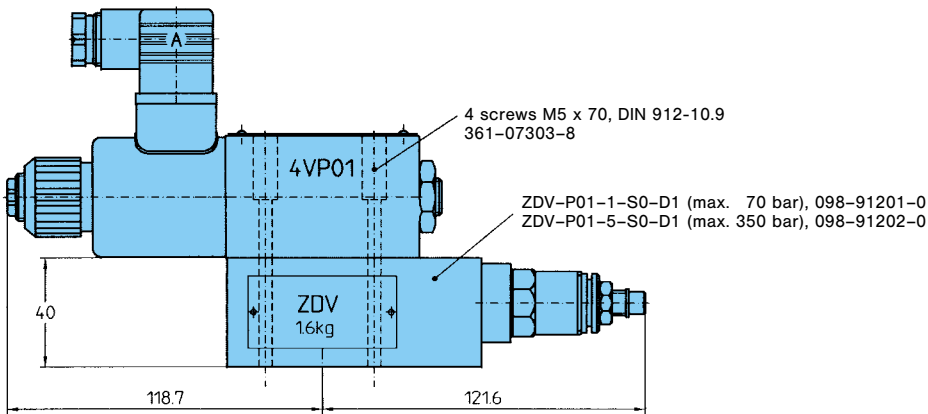

Ordering Code

4VP01 * * G12 B * ** *

Series

Pressure Range

- 1 = ... 50 bar
- 2 = ... 105 bar
- 3 = ... 210 bar
- 5 = ... 350 bar

Orifice in P

- 0 = without orifice
- 1 = 0.6 mm dia.
- 2 = 0.8 mm dia.
- 3 = 1.0 mm dia.
- 4 = 1.2 mm dia.

Modification

Electrical Connector
w/o code = connector not supplied
C1 = connector PG 11

Seal Class

- 1 = NBR-seals (Standard)
- 4 = EPDM-seals
- 5 = FPM-seals (Viton)®

Design Letter

Solenoid Voltage
G12 = 12 VDC

MOUNTING CONFIGURATION, SUBPLATES FOR 4VP01

MOUNTING CONFIGURATION (according to CETOP, ISO and DIN)

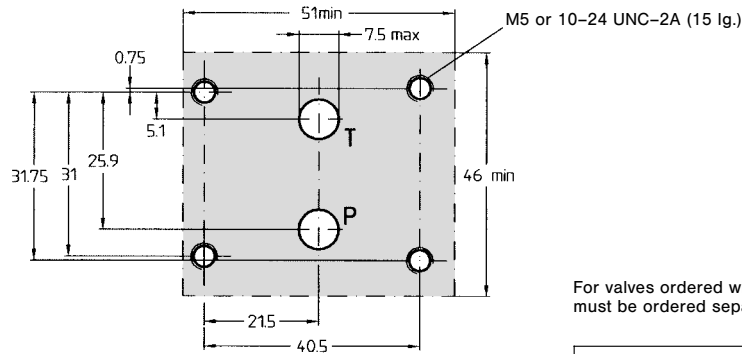

Block mounting face

Flatness 0.01 mm / 100 mm length

Surface finish $\sqrt{0.8}$

For valves ordered without subplate, mounting screws must be ordered separately.

4 Mounting screws	Order-No.
M 5 x 30, DIN 912; 10.9	700-70834-8
or 10-24 UNC-2A x 1 1/4" (SAE)	358-10183-8

Torque 8.3 Nm

SUBPLATES

1/4" & 3/8" Subplates

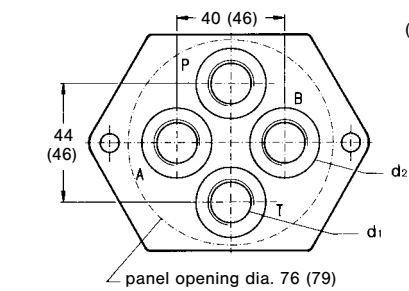

() dimensions in brackets are for 3/8" subplates

Note:
Ports A & B
not required

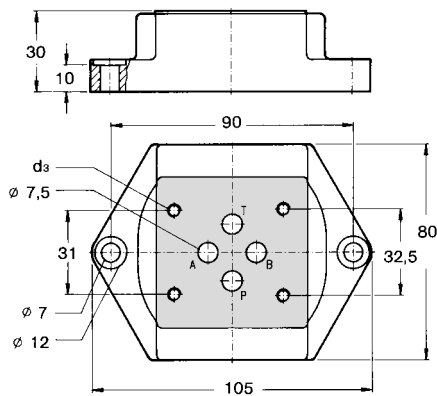

1/2" Subplate

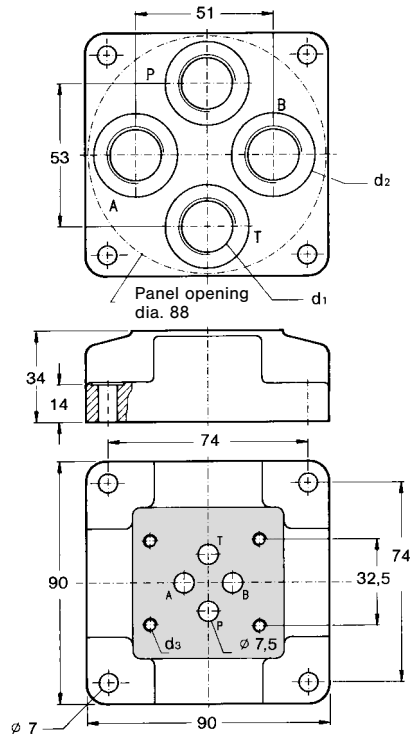

Model No.	Order No.	Weight	d ₁ (A, B, P, T)	d ₂	Thread for mount. screws d ₃
SS-B-04-G 136	S26-32959-0	1.4 kg	G 1/4"	∅ 23 x 1	M 5
SS-B-06-G 136	S26-32960-0	1.4 kg	G 3/8"	∅ 26 x 1	M 5
SS-B-08-G 136	S26-32961-0	1.7 kg	G 1/2"	∅ 31 x 1	M 5

Mounting screws are included in subplate order.

PROPORTIONAL AMPLIFIER WITH RAMPS

Order No.: 701-00600-8

Weight: 0.25 kg



This proportional amplifier is designed to control directly operated pressure valves. It proportionally converts electrical input signals into solenoid current.

This amplifier has reverse polarity protection and short circuit protected PWM-output stage with max. current limit.

The command signal is always connected to the same input line. The different command signals are set by DIP-switches on the main board. Potentiometers are available for the adjustment of ramp circuits up/down (independently from each other), max. pressure (I_{max}) and min. pressure (I_{min}).

By changing the input signal from 0...2% of max. command signal, the amplifier passes over to the "Imin-leap"-function.

There are diagnostic LED's to display the working condition (POWER ON), ramp function (RAMP OFF) and "FAIL SAFE" in case of short circuit or external STOP of the card. Two measuring sockets are provided to measure either the nominal solenoid current or the command voltage.

Characteristics – Proportional Amplifiers

- Supply voltage
 - nominal 24 V DC
 - smoothed battery voltage 20...32 V DC
- Reference voltage
 - $\pm 15 \text{ V} / 25 \text{ mA} \pm 5\%$
 - $\pm 10 \text{ V} / 10 \text{ mA} \pm 0.5\%$ stabilised
- Solenoid nominal current $I_{max} = 2.3 \text{ A}$
- Current consumption max.
 - 12 V solenoid approx. 2.5 A
- Short circuit protection for solenoid
- Inputs
 1. 0...20 mA, 100 Ω input impedance
 2. 4...20 mA, 100 Ω input impedance
 3. 0... 5 V, 50 k Ω input impedance
 4. 0...10 V, 100 k Ω input impedance
- Outputs
 - + = solenoid A
- External stop illuminates on "Fail Safe", implement as NC (normally closed circuit) connection with an input voltage of 24 V; input impedance 3.3 k Ω
- Ramp off illuminates when "Ramp off", implement as NO (normally open circuit) connection with an input voltage of 24 V; input impedance 3.3 k Ω
- Potentiometer for
 - max. pressure (I_{max}) ...2.3 A
 - min. pressure (I_{min}) 0...50% of I_{max} ; 20% factory set
 - ramp up 0.1...10 s $\pm 20\% \triangleq 1...100 \text{ V/s}$
 - ramp down 0.1...10 s $\pm 20\% \triangleq 1...100 \text{ V/s}$
- PWM-frequency 6.2 kHz $\pm 20\%$
- Dither frequency 270 Hz
- Measuring socket
 - solenoid current $1 \text{ V} \triangleq 1 \text{ A} \pm 5\%$
 - command voltage approx. 0...10 V at 100% command signal (depends on I_{max} -adjustment)

Note:

Power supply, Potentiometer, Card holder see page 12.

See publication 9-EN 6010 for further detail information on Proportional Amplifier 701-00600-8.

PROPORTIONAL AMPLIFIER WITH RAMPS

Dimensions Plug-in module 3U/8HP according to IEC 297

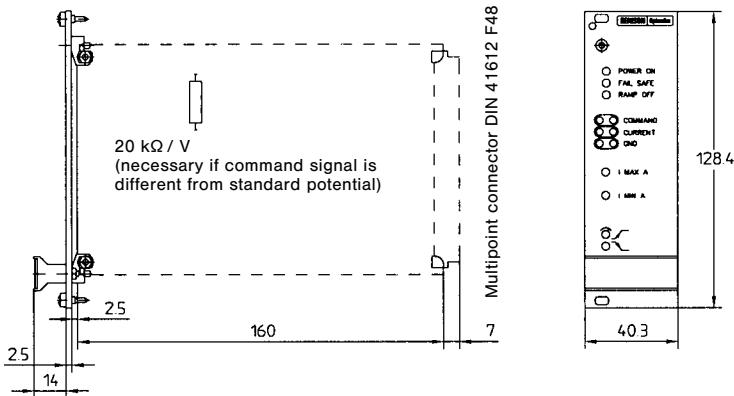

Details on the front plate

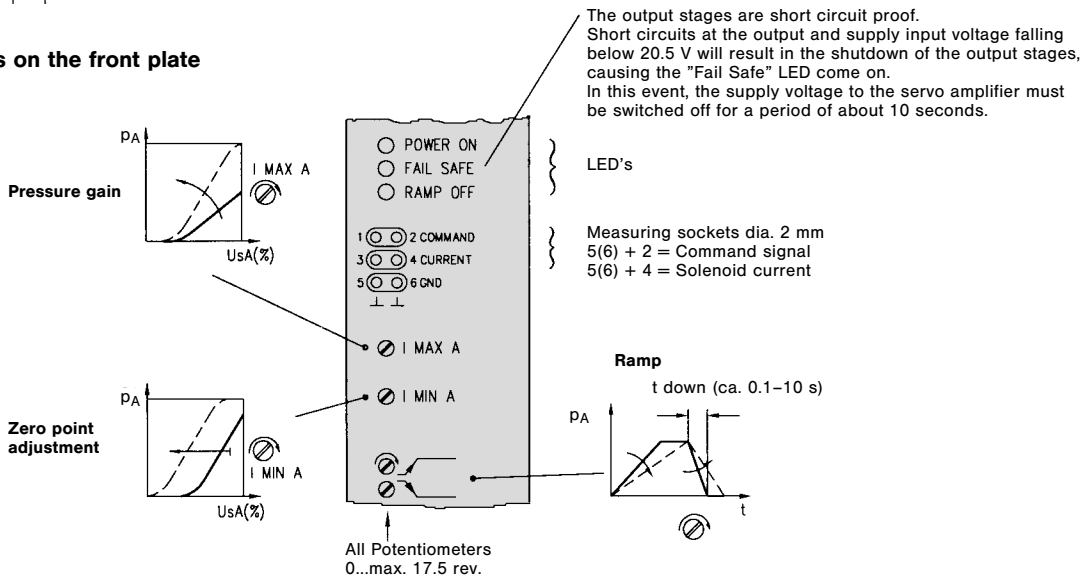

Schematic block diagram and terminal assignment

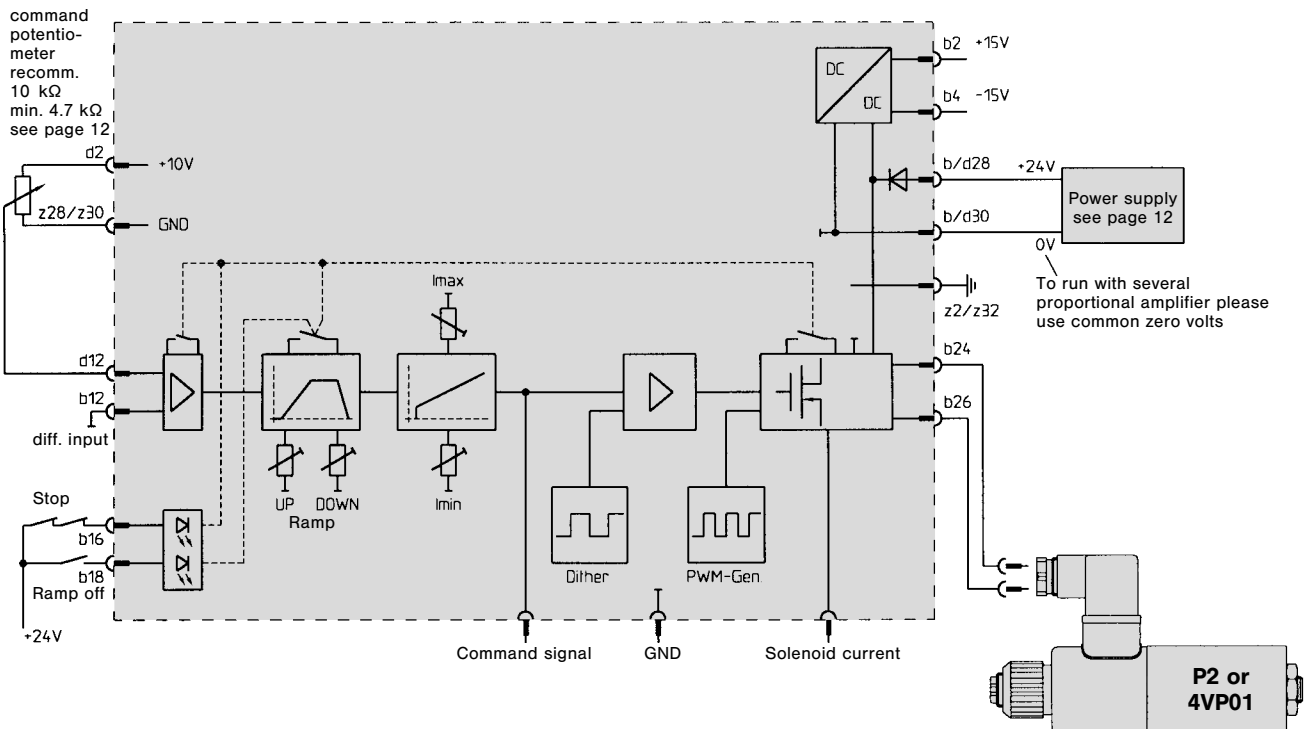

COMMAND CARD FIVE CHANNEL

Order No.: 701-00028-8
Weight: 0.15 kg

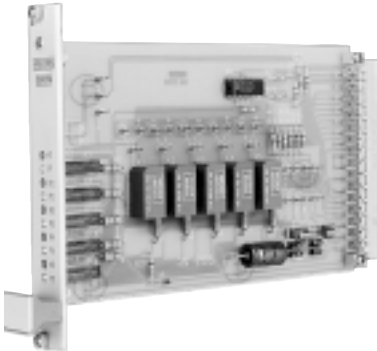

This command card is designed to interface with all proportional amplifiers for DENISON proportional valves.

Five multiturn-potentiometers (P1...P5) allow different command signals. Selection is made by external energizing of the five selector relays on the command card. By moving the soldered bridges (+/-) it is possible to preset positive or negative commands for the desired level and direction.

In addition, the command card has a summing amplifier which enables the monitoring of the internal commands (soldered bridges 1...5), or additional external resistor array.

These inputs (e.g. a 4) also make it possible to cascade further command cards if required.

The output signal to the servo amplifier is available "not inverted" (a 2) and "inverted" (c 2).

The command card has a power rectifier with a 24 V DC output (input 24 V AC). Via the output c 30/32, the command relays can be energized.

All potentiometers are adjustable on the front panel.

The operating status of the corresponding command is indicated by an LED display on the front panel (K1...K5).

LED on = Command level selected.

Characteristics – Command Card

- | | |
|--|--|
| • Supply voltage: | |
| – command card | supply from proportional amplifier |
| – rectifier | 24 V AC (min. 19 V AC) |
| • Command potentiometer | 5 potentiometers 0...10 V |
| • Command relays | 5 potential free contacts |
| • Relay contacts: | |
| – max. current on contact (resistive load) | 100 mA |
| – max. switching voltage | 30 V |
| – coil voltage | 24 V DC, approx. 30 mA incl. LED-display |

Euro-Card-Holder

Order No. 701-00007-8
Holder for individual mounting according to DIN 41612 design D32

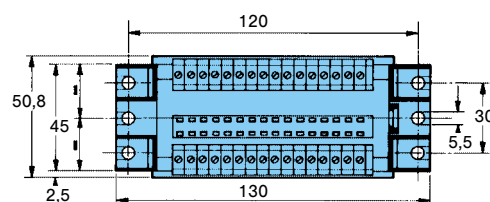
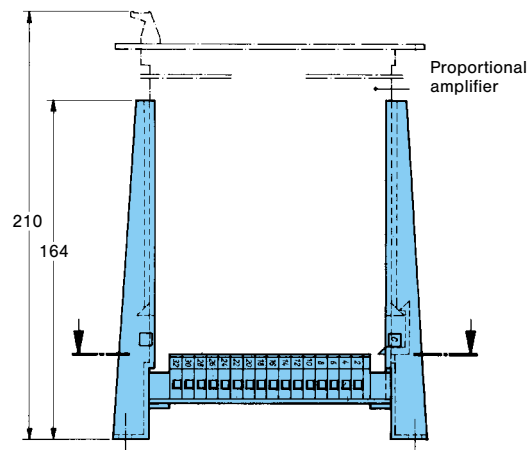

COMMAND CARD FIVE CHANNEL

Dimensions Plug-in module 3HE/4TE according to IEC 297

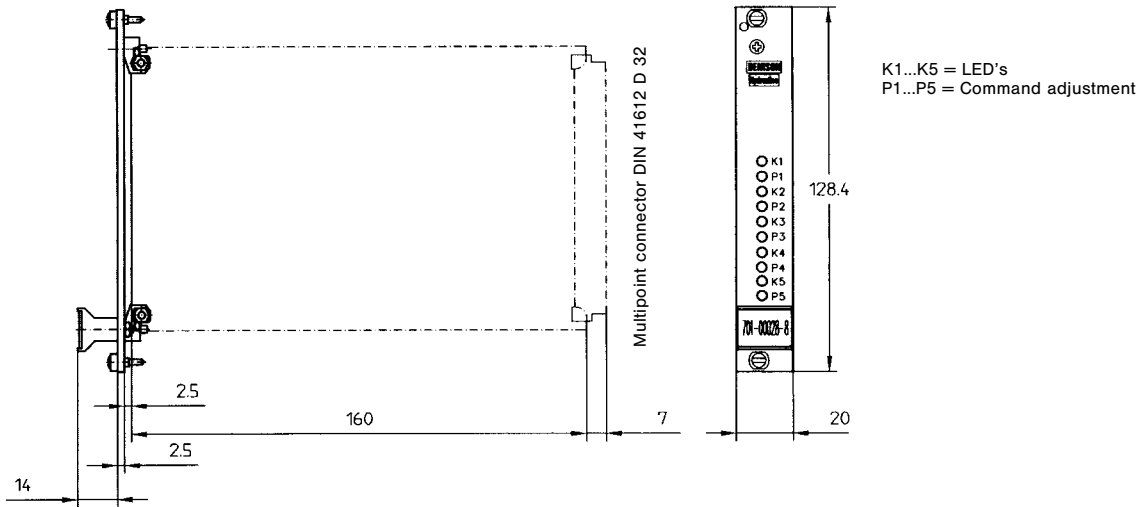

Schematic block diagram and terminal assignment

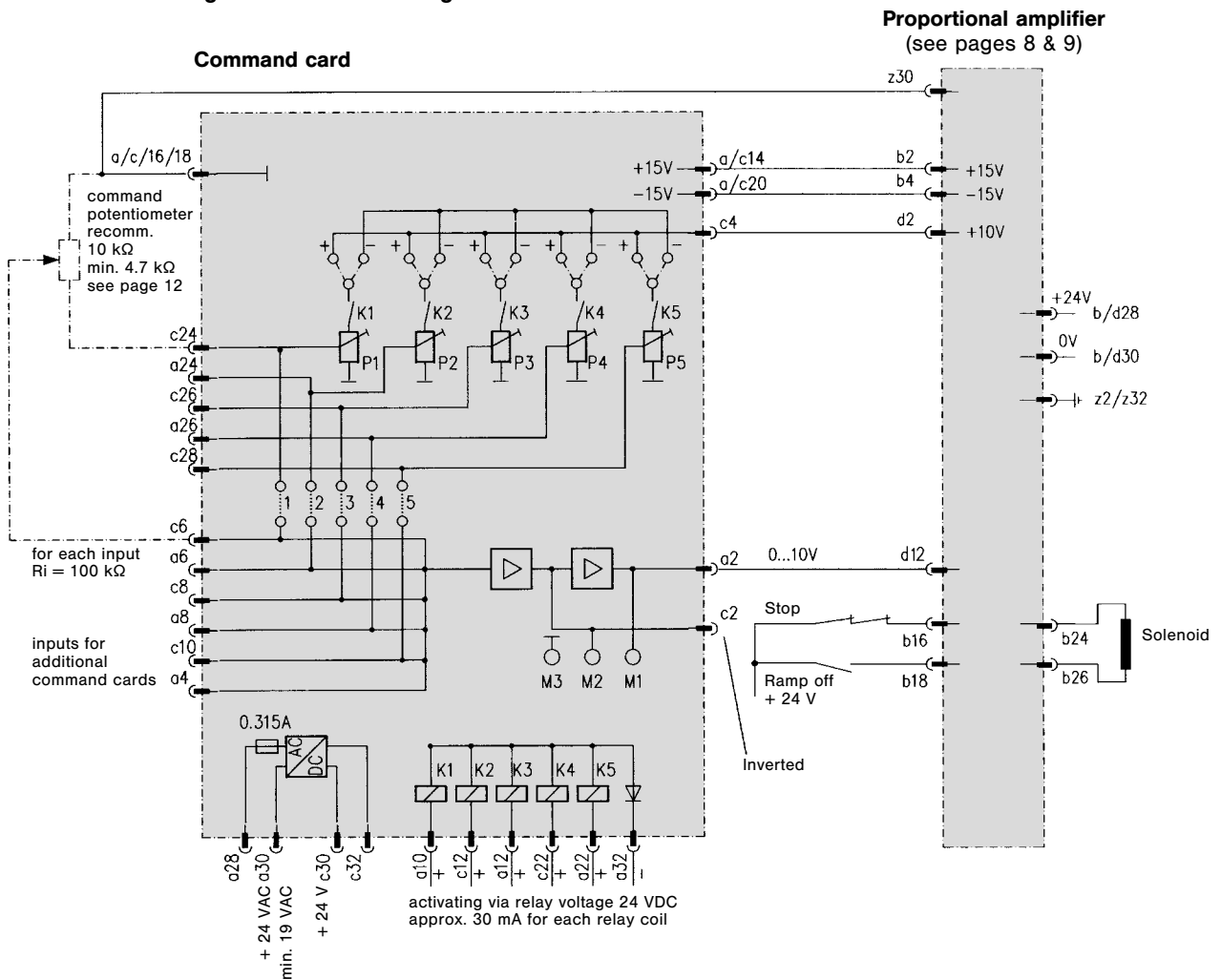

ACCESSORIES

Potentiometer-Adjusting knob
Order No. 701-00014-8

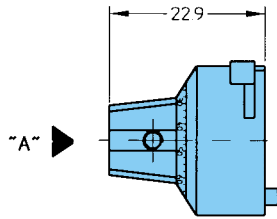
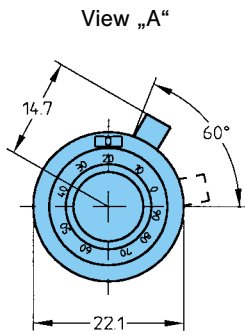

Potentiometer

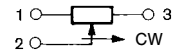
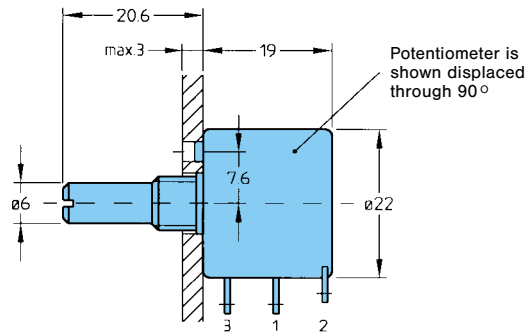

Adjusting knob with scale 0...100 and with revolution counter. Adjustment is lockable.

Panel opening

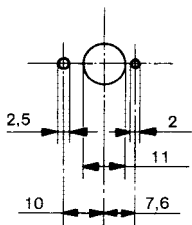

Potentiometer Characteristics	Potentiometer Order No.	
	701-00012-8	701-00013-8
Angle of rotation	360°	3600°
Linearity	± 0.5%	± 0.25%
Resolution-Drift	0.11% of 360°	0.02% of 3600°

Power supply
Order No. 701-00023-8
Weight: 0.25 kg

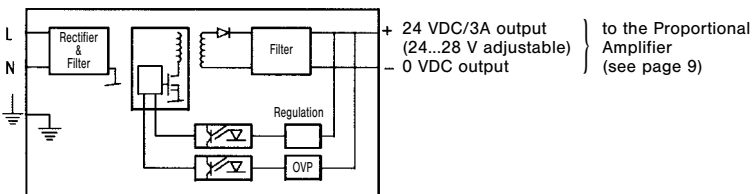
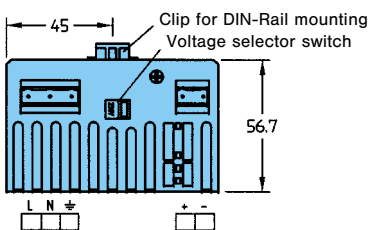
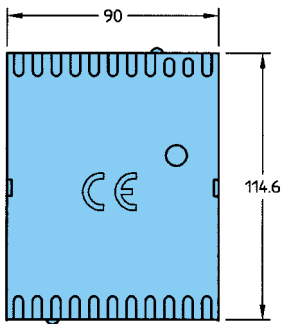

L = Nominal frequency 50/60 Hz
Nominal voltage 230 VAC or 115 VAC (pay attention to voltage selector switch setting)
N = Neutral line

Euro-Card-Holder

Order No. 701-00066-8
Holder for individual mounting according to DIN 41612, design F48

