

# HIGH PRESSURE BALL VALVES

## KHB3K Series

3-way Diverter Ball Valves

[www.khadamathydraulic.com](http://www.khadamathydraulic.com)  
 Tell: 021-55882749  
 Tell: 021-33488178  
 Fax: 021-33488105



### Specifications

- 1/4" - 1" Full Port Design
- 2 Position
- Carbon Steel Housing
- NPT or SAE O-Ring Connections
- Ball Seals: Polyacetal (*standard*)
- O-Rings: Fluoroelastomer (*FPM*) (*standard*)
- Operating Pressure: to 7250 psi depending on valve size and seal materials selected
- Temperature Range: 14° to 176°F with standard materials (*1114*) up to maximum pressure rating. Extended temperature range -40° to 392°F on request with special materials and reduced pressure rating (*see page A1-3*).

### Model Code

**KHB3K - 16 NPT - L - 1 1 1 4 - 11X - A - L**

#### Housing Type

KHB3K = Three-Way Diverter Ball Valve

#### Nominal Sizes

Nom Size	SAE Tube	SAE Thread	NPT Pipe Size	NPT Pipe OD
06	-4	7/16-20 UNF	1/4"	0.540"
10	-6	9/16-18 UNF	3/8"	0.675"
16	-8	3/4-16 UNF	1/2"	0.840"
20	-12	1-1/16-12 UN	3/4"	1.050"
25	-16	1-5/16-12 UN	1"	1.315"
32	-20	1-5/8-12 UN	1-1/4"	1.660"
40	-24	1-7/8-12 UN	1-1/2"	1.900"
50	-32	2-1/2-12 UN	2"	2.375"

#### Connection Type

NPT = ANSI/ASME 1.20.1 Taper Pipe Thread  
 SAE = SAEJ1926 Ports with ISO 725 Threads and O-Ring Sealing

#### Ball Drilling

L = standard

#### Body Material

1 = Carbon Steel (*phosphate coated*)

#### Spindle and Ball Material

1 = Carbon Steel (*ball is chrome plated, spindle is zinc plated*)  
 3 = Stainless Steel

#### Ball Seal Material

1 = Polyacetal (*standard*)  
 3 = PTFE (*1500 psi max*)

#### O-Ring Material

2 = NBR (*Buna N*)  
 3 = PTFE Spindle Seals and FPM (*Fluoroelastomer*) O-Rings (*1500 psi max*)  
 4 = FPM (*Fluoroelastomer*) (*standard*)

#### Handle Codes

09x = Without Handle  
 11x = Straight Aluminum, Sizes 06-25  
 16x = Offset Steel Handle, Sizes 32-50

#### Housing Surface Finish

A = Zinc plated (*standard for all carbon steel valves*)  
 (omit) = No plating for Stainless Steel

#### Locking Device Option

L = Locking Device (*see page A1-22 to order locking device separately*)  
 LS = Locking Device with 5 amp Limit Switch, Available for Sizes 20-50 (*Not available with PTFE Spindle Seals*)

## Dimensions

### Sizes 06 - 25

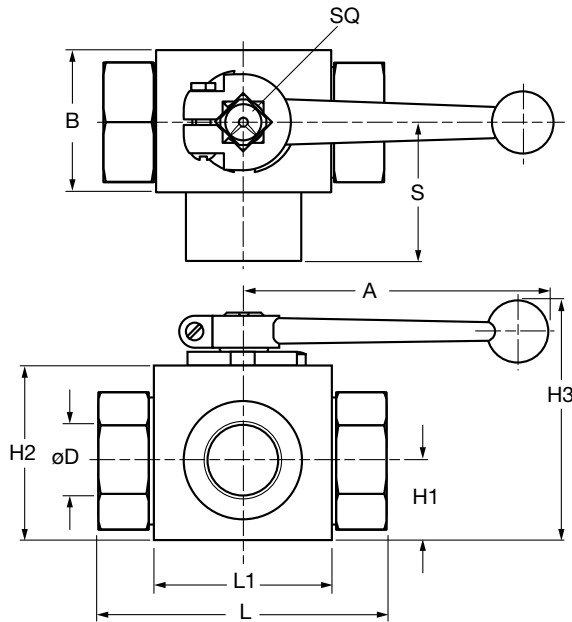

### Sizes 32 - 50

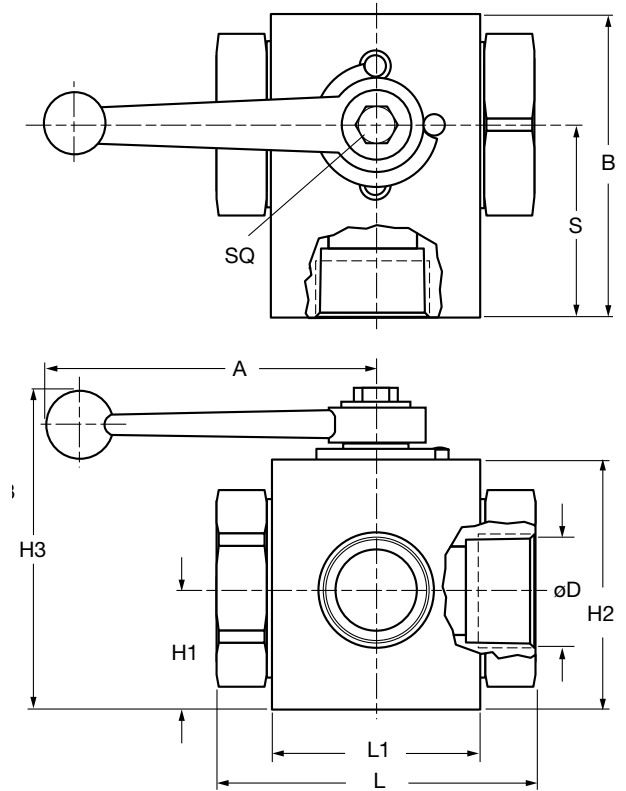

## Ball Drilling

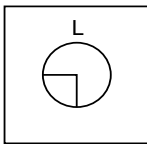

## Function Diagrams

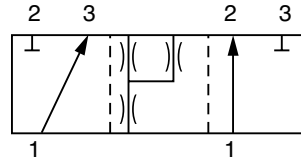

Notes: Pressure port 1 should always be the highest pressure port

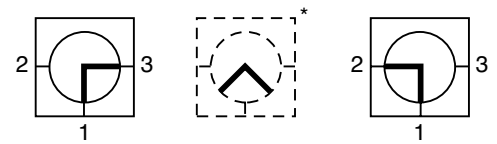

At intermediate position flow will not be completely shut off.  
Notes: Valve is not designed to be used as a flow control valve. Valve should not be left in an intermediate position to avoid seal damage.

Model	Port Threads	Max. psi*	A	B	øD	H1	H2	H3	L	L1	SQ	S	Weight
KHB3K-06SAE...	7/16"-20 UNF	7250	5.90	1.02	0.24	0.51	1.26	1.65	2.72	1.46	0.35	1.36	0.88
KHB3K-06NPT...	1/4" NPT		(150)	(26)	(6)	(13)	(32)	(42)	(69)	(37)	(9)	(34.5)	(0.4)
KHB3K-10SAE...	9/16"-18 UNF	7250	5.90	1.26	0.39	0.67	1.57	1.69	2.83	1.65	0.35	1.42	1.32
KHB3K-10NPT...	3/8" NPT		(150)	(32)	(10)	(17)	(40)	(47)	(72)	(42)	(9)	(36)	(0.6)
KHB3K-16SAE...	3/4"-16 UNF	5800	6.89	1.50	0.63	0.75	1.77	2.01	3.27	1.85	0.47	1.64	1.76
KHB3K-16NPT...	1/2" NPT		(175)	(38)	(16)	(19)	(45)	(51)	(83)	(47)	(12)	(41.5)	(0.8)
KHB3K-20SAE...	1-1/16"-12 UN	5000	7.87	1.93	0.79	1.08	2.36	2.28	3.74	2.36	0.55	1.87	3.31
KHB3K-20NPT...	3/4" NPT		(200)	(49)	(20)	(27.5)	(60)	(58)	(95)	(60)	(14)	(47.5)	(1.5)
KHB3K-25SAE...	1-5/16"-12 UN	5000	7.87	2.28	0.98	1.16	2.56	2.40	4.45	2.56	0.55	2.22	4.85
KHB3K-25NPT...	1" NPT		(200)	(58)	(25)	(29.5)	(65)	(61)	(113)	(65)	(14)	(56.5)	(2.2)
KHB3K-32SAE...	1-5/8"-12 UNF	5000	9.00	4.35	1.18	1.70	3.54	5.47	4.53	2.99	0.67	2.76	7.7
KHB3K-32NPT...	1-1/4" NPT		(228)	(110.5)	(30)	(43.3)	(90.0)	(139)	(115)	(76)	(17)	(70)	(3.5)
KHB3K-40SAE...	1-7/8"-12 UN	5000	9.00	4.69	1.38	1.71	3.79	5.71	5.31	3.35	0.67	2.95	11
KHB3K-40NPT...	1-1/2" NPT		(228)	(119)	(35)	(43.5)	(96.2)	(145)	(135)	(85)	(17)	(75)	(5)
KHB3K-50SAE...	2-1/2"-12 UN	5000	9.00	5.73	1.73	2.35	4.72	6.02	5.91	4.72	0.67	3.35	16.5
KHB3K-50NPT...	2" NPT		(228)	(145.5)	(44)	(59.8)	(120)	(153)	(150)	(120)	(17)	(85)	(7.5)

\*Dependent upon valve and seal materials selected.

Notes:

1. Dimensions are in inches (mm) and lbs (kg)

2. Dimensions are for general information only, all critical dimensions should be verified by requesting a certified print.