

## SRVR Series

Pressure Compensated Flow Control Valves

www.khadamathydraulic.com  
 Tell: 021-55882749  
 Tell: 021-33488178  
 Fax: 021-33488105

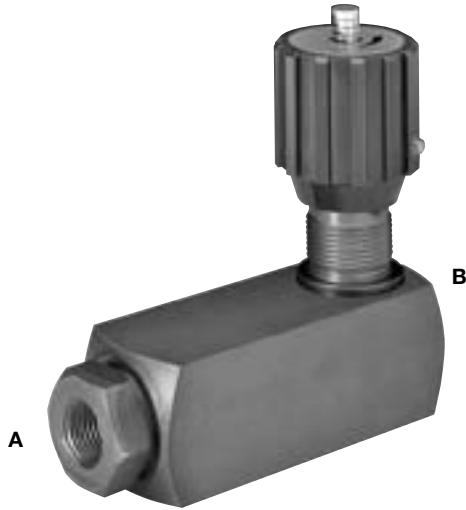

### Specifications

- 4 sizes, 1/4" - 3/4"
- Working Pressure:  
 Inlet: 102 psi min. / 3045 psi max.  
 Outlet: 0 psi min. / 2944 psi max.
- Flows to 24 gpm
- NPTF Connections
- Carbon Steel Housing
- FPM (Fluoroelastomer) O-Rings (standard)
- Color coded spindle for accurate flow control
- Provision for panel mounting
- Unique safety spindle design
- Temperature Range: -4° to 212°F at full pressure
- Viscosity Range: 13 SUS min. / 1781 SUS max.

### Hydraulic Symbol

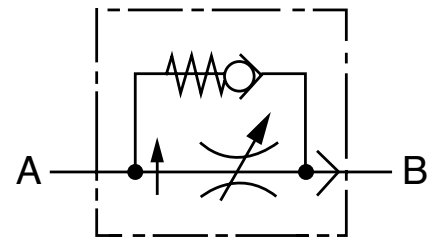

### Model Code

#### Pressure Compensated Flow Control Valve

SRVR = Flow Control Valve (with internal check valve)

#### Nominal Size

NPTF Only			
	Pipe Size	Pipe OD	BSP
08	= 1/4"	0.540"	G1/4
10	= 3/8"	0.675"	G3/8
12	= 1/2"	0.840"	G1/2
16	= 3/4"	1.050"	G3/4

#### Housing Material

01 = Carbon Steel

#### Modification Number

#### Port Configuration

0 = BSPP to DIN 3852, Part 2 -X  
 5 = NPTF (ANSI B1.20.3)

#### Supplementary Details

S = Panel Mounting Kit

SRVR - 08 - 01 .X / 5 - S

# FLOW CONTROL VALVES

## Pressure Drop Curves

Flow Direction: A to B / Throttled Flow

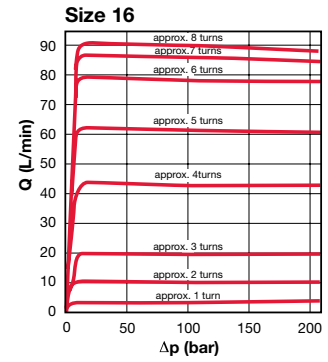
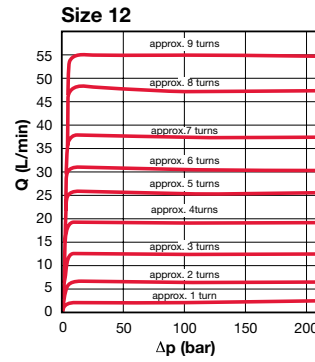
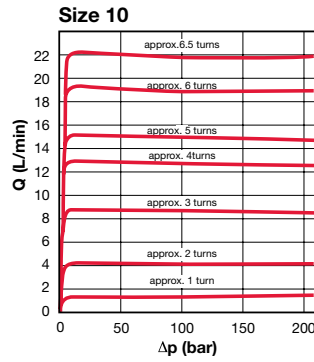
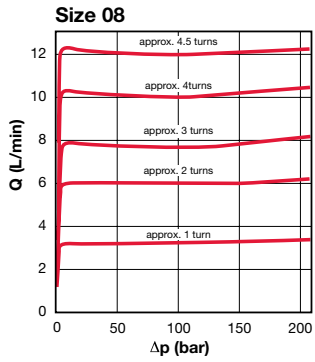

Flow Direction: B to A / Free Flow Through Check Valve

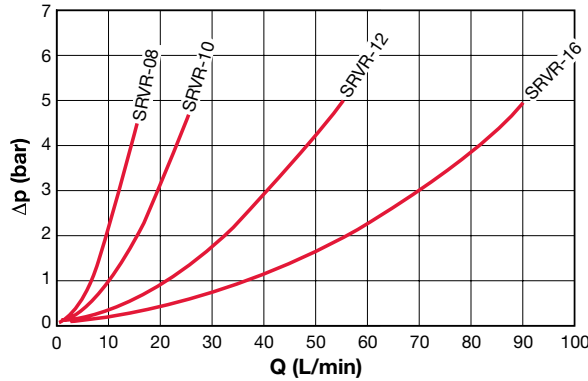

## Dimensions

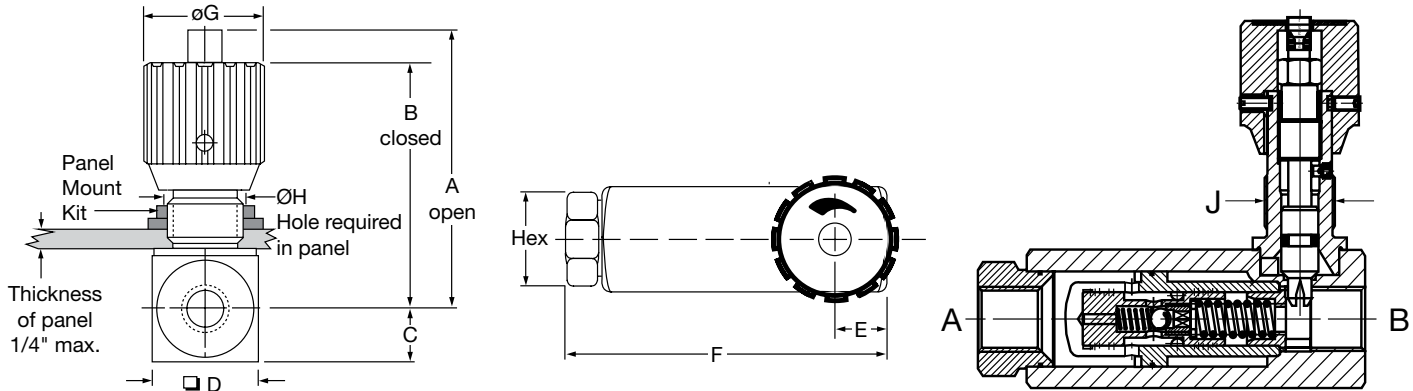

Model Code	Size	A	B	C	D	E	F	Ø G	Ø H	J+ thread	Hex	Weight
SRVR-08	1/4" NPTF	2.91 (74)	2.64 (67)	0.59 (15)	1.18 (30)	0.69 (17.5)	3.62 (92)	1.14 (29)	0.75 (19)	Pg 11	0.94 (24)	1.3 (0.6)
SRVR-10	3/8" NPTF	3.62 (92)	3.23 (82)	0.69 (17.5)	1.38 (35)	0.71 (18)	4.13 (105)	1.50 (38)	0.91 (23)	Pg 16	1.06 (27)	2.0 (0.9)
SRVR-12	1/2" NPTF	4.17 (106)	3.78 (96)	0.89 (22.5)	1.77 (45)	0.83 (21)	4.92 (125)	1.50 (38)	0.91 (23)	Pg 16	1.26 (32)	3.8 (1.7)
SRVR-16	3/4" NPTF	4.27 (108.5)	3.88 (98.5)	0.98 (25)	1.97 (50)	1.02 (26)	5.51 (140)	1.50 (38)	0.91 (23)	Pg 16	1.61 (41)	4.9 (2.2)

\*Pg style thread per DIN 40430

Notes:

1. Dimensions are in inches (mm) and lbs (kg).
2. Dimensions are for general information only, all critical dimensions should be verified by requesting a certified print.

## Panel Mount Kits

Size	Model Code	Part Number
08	Kit Panel Mount DV08	00705310
10/12/16	Kit Panel Mount DV12	00705302