

SAW Series Directional Control Valve with Monitoring Switch

26.4 gpm
5075 psi

Features

This valve is a spool activated directional control valve that uses mechanical detection to operate a switch to send an electric ON/OFF signal. This makes it possible, by monitoring the status of the spool operations, to use it as an information source for safety checks by using the ON/OFF signal as a basis for sequence control. In the future, they will be used in machinery that is compatible with inter-

national machine safety (ISO 12100) and JIS standards (JIS B 9700) standards.

The directional control valve with monitoring switch was developed as a valve to support this demand. The switch contact has little dead zone and almost no temperature drift (variable motion caused by changes in temperature) or hysteresis because the

reaction of the spool action is mechanical.

All valve functions, except for the monitoring function, are equivalent to the standard solenoid operated directional control valve (SA-GO1). DIN connectors are used for the switches and solenoid coil wiring so connections are easy when installing or replacing valves.

Operational Principle

When the spool is in the center position, the fixed and moving parts are in contact forming an electric circuit. Operating the solenoid moves the spool so the moving part moves breaking the electric connection between the fixed and moving parts. PAT. PEND.

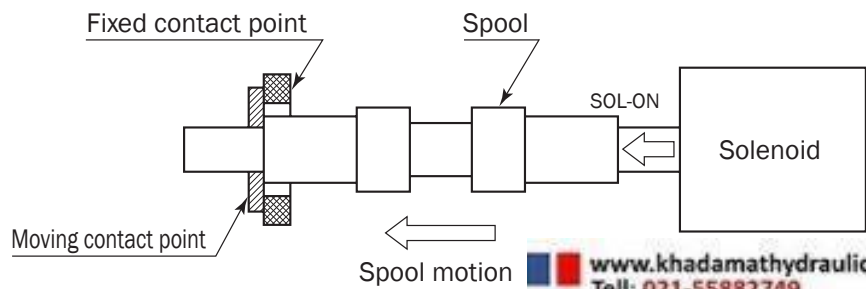

www.khadamathydraulic.com
 Tell: 021-55882749
 Tell: 021-33488178
 Fax: 021-33488105

Specifications

Model No.		Standard Type		Shockless Type	
JIS Symbol	Operation Symbol	Maximum Working Pressure psi	Maximum Flow Rate gpm	Maximum Working Pressure psi	Maximum Flow Rate gpm
	-A2X-	5075	7.9	3625	7.9
	-A3X-		21.1		13.2
	-A5-		26.4		
	-C1-		21.1		
	-C5-		26.4		
	-C6-		21.1		
	-C1S-		26.4		
	-C6S-				

Note: The maximum flow rate of each valve depends on the pressure. For details, see page D-68.

• Valve Specifications

		AC Solenoid	DC Solenoid	
			Built-in Rectifier	
Maximum Working Pressure P, A, B ports	Standard Type	5075 psi		
	Shockless Type	3625 psi		
Maximum Allowable Backpressure T port		3045 psi		
Maximum Flow Rate		See pressure-flow characteristics on page D-68 for more information.		
Switching Frequency		120/minute		
Weight	Double Solenoid	6.1 lbs	6.6 lbs	
	Single Solenoid	4.6 lbs	4.8 lbs	
Operating Environment	Dust Resistance/Water Resistance Rank	JISC 0920 IP65		
	Operating Fluid	Oil-based operating fluid (Note 1)		
	Ambient Temperature Range	-4 to 122° F		
	Operating Fluid Temperature Range	-4 to 158° F		
	Operating Viscosity Range	15 to 300 centistokes		
	Filtration	10 µm or less		
Mounting bolt (Note2)	Size × Length	Socket hex head bolt (grade 8 equivalent) 10-24 x 1 3/4		
	Tightening Torque	3.6 to 5 ft lbs		

- Note: 1. Use a petroleum based operating fluid because the ON/OFF mechanism of the valve's monitoring switch is immersed in oil and the oil must be a non-conducting fluid.
 Use only petroleum based operating fluid (do not use fluids that are water, glycol, W/O emulsion, phosphate, or fatty ester based).
 Petroleum based operating fluids must also have a water content that is less than 0.1% by volume.
 2. Installation bolts are not provided with valves. Use the specified bolts.

• Monitoring Switch Specifications

Voltage Rating	24VDC
Allowable Voltage Range	± 20% of voltage rating
Maximum Current Load	100mA
Residual Voltage (Note 3)	Max. 1.2V
Wiring for Connector for Switch	Connect with wires or M12-4 pin connector

- Note: 1. See page D-67 for the procedure to wire the connector for the switch.
 2. The programmable controller input circuits are positive (+) common mode and negative (-) common mode.
 The directional control valve with monitoring switch uses a source circuit [switch on the positive (+) side of the load and power source] for safety purposes.
 Because of this, it is necessary to use a negative (-) common mode programmable controller to receive input from the monitoring switch output.
 3. Set the voltage of the power supply to the monitoring switch within a range that satisfies the following conditions.
 Load ON voltage + residual voltage ≤ switch supply voltage ≤ 28.8 V (+20% voltage rating)
 4. The switch element (photocoupler) in the connector's internal circuit for the monitoring switch may malfunction in the ON state because of over voltage or over current.
 Therefore, in addition to checking the ON output of the monitoring switch, monitor the current at the solenoid and the internal circuits of the connector and valve in conjunction with the switch output.

Condition of monitoring switch output and valve

		Current to Solenoid	
		ON	OFF
Monitoring Switch Output	ON	Abnormal Malfunction at internal circuit of connector or valve	Normal Spool returns to middle position
	OFF	Normal Spool is switching	Abnormal Valve malfunction or signal wire is cut

The monitoring switch outputs according to the motion of the spool, so the solenoid turns on and off according to the output signal which is delayed only as much as the spool operation is delayed.
 Set a 0.3 second delay, including leeway, to monitor the output of the switch.

• Solenoid Specifications

Same specifications as the SA-G01 series (31 design).

Solenoid Type	Power Supply Type	Voltage (V)	Frequency (Hz)	Solenoid Coil Type	Drive Current (A)	Holding Current (A)	Holding Power (W)	Allowable Voltage Range (V)
AC	C1	AC100	50	EAC64-C1	2.2	0.52	25	80 to 110
			60		2.0	0.38	22	90 to 120
		AC110	60		2.2	0.46	28	
	C115	AC110	50	EAC64-C115	2.0	0.47	25	90 to 120
			60		1.8	0.35	22	100 to 130
		AC115	60		2.0	0.42	28	
	C2	AC200	50	EAC64-C2	1.1	0.26	25	160 to 220
			60		1.0	0.19	22	180 to 240
		AC220	60		1.1	0.23	28	
	C230	AC220	50	EAC64-C230	1.0	0.24	25	180 to 240
			60		0.91	0.17	22	200 to 260
		AC230	60		1.0	0.21	28	
DC with Built-in Rectifier	E1	AC100	50/60	EAC64-E1-1A	0.31		27	90 to 110
	E115	AC110	50/60	EAC64-E115-1A	0.26		25	100 to 125
		AC115			0.27		27	
	E2	AC200	50/60	EAC64-E2-1A	0.15		26	180 to 220
	E230	AC220	50/60	EAC64-E230-1A	0.12		24	200 to 250
AC230		0.13			27			
DC	D1	DC12	—	EAC64-D1-1A	2.2		26	10.8 to 13.2
	D2	DC24	—	EAC64-D2-1A	1.1		26	21.6 to 26.4

• Handling

- In order to realize the full benefits of the wet type solenoid valve, configure piping so oil is constantly supplied to the T port. Never use a stopper plug in the T port.
- Ensure that surge pressure in excess of the maximum allowable back pressure does not reach the T port.
- Note that the maximum flow rate is limited when used as a four-way valve, or by blocking ports for use as a two-way valve or one-way valve.
- Always keep the operating fluid clean. Allowable contamination is class NAS12 or less.
- Use a ISO VG 32 petroleum-based operating fluid, or an equivalent, that has a water content that is less than 0.1% by volume.
- Do not use fire-resistant operating fluid.
- Use this valve only within the allowable voltage range.
- Do not allow the AC solenoid to become

- charged until you install the coil into the valve.
- In the case of operation symbol A2X, run drain piping from the valve T port.
- Maintaining a switching position under high pressure for a long period can cause abnormal operation due to hydraulic lockup. Contact your agent when you need to maintain a switching position for a long period.
- Note that manual pin operating pressure changes in accordance with tank line back pressure.
- The solenoid has a pin for switching the spool manually. However, use the cap (option symbol: D) to prevent manual operation for jobs where manual operation would cause a safety problem.
- The only way to prevent misoperation of the monitoring switch caused by noise generated by the solenoid turning on and off is to install the surgeless

- directional control valve with monitoring switch (option symbol: GR). (If the solenoid power source is C* and D*)
- Use surgeless specification (with varistor diode) directional control valves with monitoring switches for all electric valves on the same machine to prevent mis-operation of the monitoring switch caused by noise when the solenoid turns on and off.
- The coil surface temperature increases if this valve is kept continuously energized. Install the valve so there is no chance of it being touched directly by hand.
- The connector for the solenoid is the same as for the SA series solenoid valve. See page D-22 for electrical circuit drawings and wiring procedures.
- Use the following table for specification when a sub plate is required.

Model No.	Pipe Diameter	Maximum Working Pressure psi	Recommended Flow Rate gpm	Weight lbs	Dimension Drawings Page
MSA-01X-E10	1/4	3625	5.2	2.6	D-20
MSA-01Y-E10	3/8		10.5		
MSA-01Y-T-E10	3/8		10.5	1.9	

Understanding Model Numbers

SAW - G 01 - A3X - FGR V - D2 - 10

Design number
10

Solenoid power supply

- C1 : AC100V 50/60Hz, AC110V 60Hz
 C115: AC110V 50/60Hz, AC115V 60Hz
 C2 : AC200V 50/60Hz, AC220V 60Hz
 C230: AC220V 50/60Hz, AC230V 60Hz
 D1: DC12V
 D2 : DC24V
 E1: AC100V 50/60Hz E115: AC110/115V 50/60Hz
 E2: AC200V 50/60Hz E230: AC220/230V 50/60Hz

Wiring for connector for switch

- None: With 350mm wire
 V : With M12-4 pin connector
 (Example of connector with cable provided by customer: Omron XS2F-D421-D80-A)

Option symbols

- None: No options (available with power supply E*)
 D : With cap to prevent operation of manual push pin
 F : Shockless type (available with power supply D* and E*)
 GR : Surgeless type, with indicator light (must be installed with power supply C* and D*)
 R : With indicator light (available with power supply E*)

Possible option symbol combinations

Power Supply	Option Symbols
C*	GR, DGR
D*	GR, DGR, FGR, DFGR
E*	None, D, F, DF, R, DR, FR, DFR

Note:

The only way to prevent misoperation of the monitoring switch caused by noise generated by the solenoid turning on and off is to install the surgeless directional control valve with monitoring switch.
 (Power supply E is the standard surgeless type, option symbol G is not needed.)

Operation Symbol

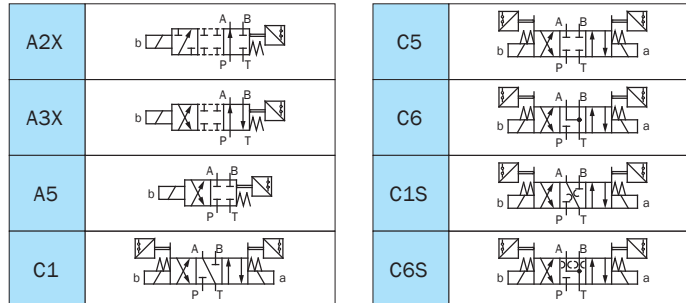

Nominal diameter
01 size (D03)

Mounting method
G: Cascade mounting

Directional control valve with monitoring switch (DIN connector type)

Note: See page D-7 for an explanation of the shockless type (option symbol F) and surgeless type (option symbol G).

Installation Dimension Drawings

Dimensions of installation surface of gasket are ISO 4401-03-02.
SAW-A**.*-10

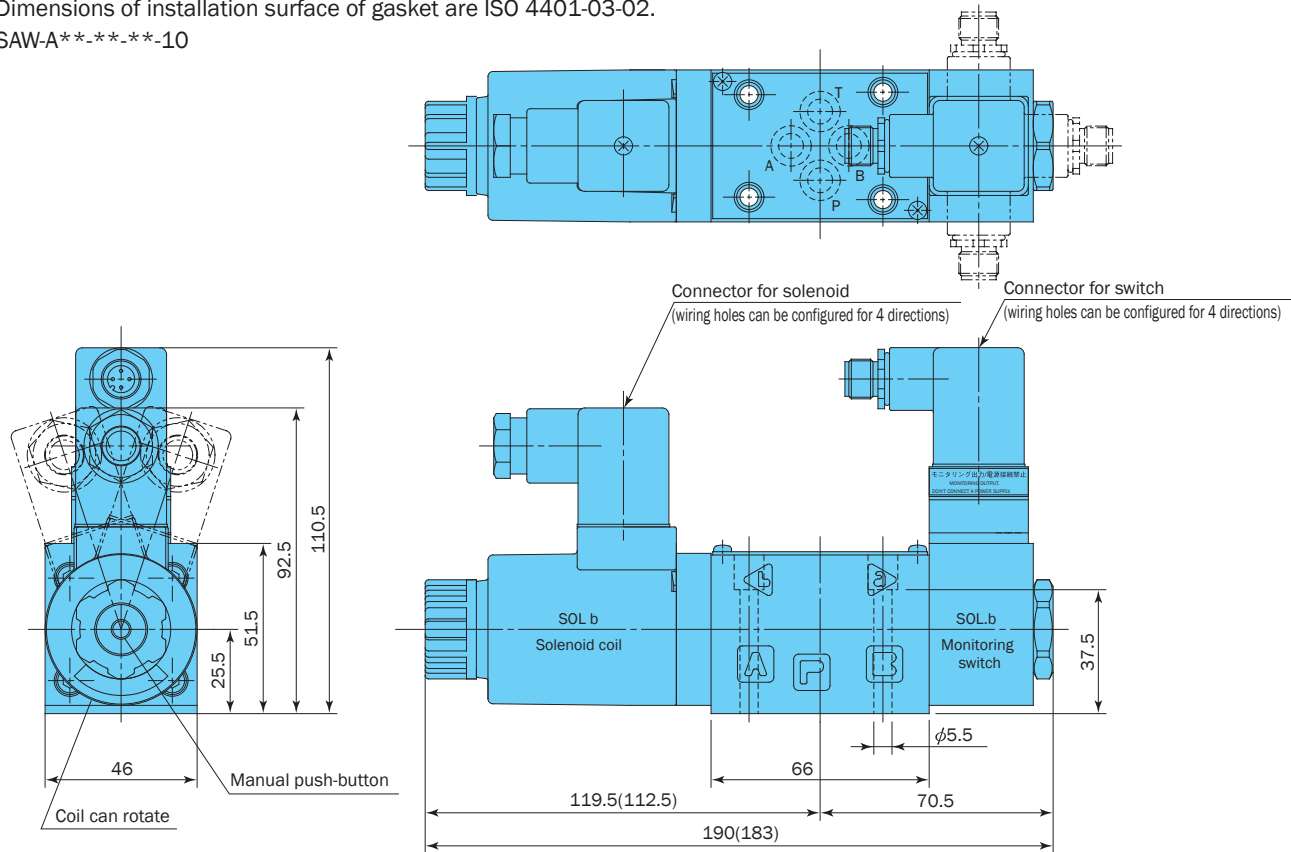

SAW-G01-C**.*-10

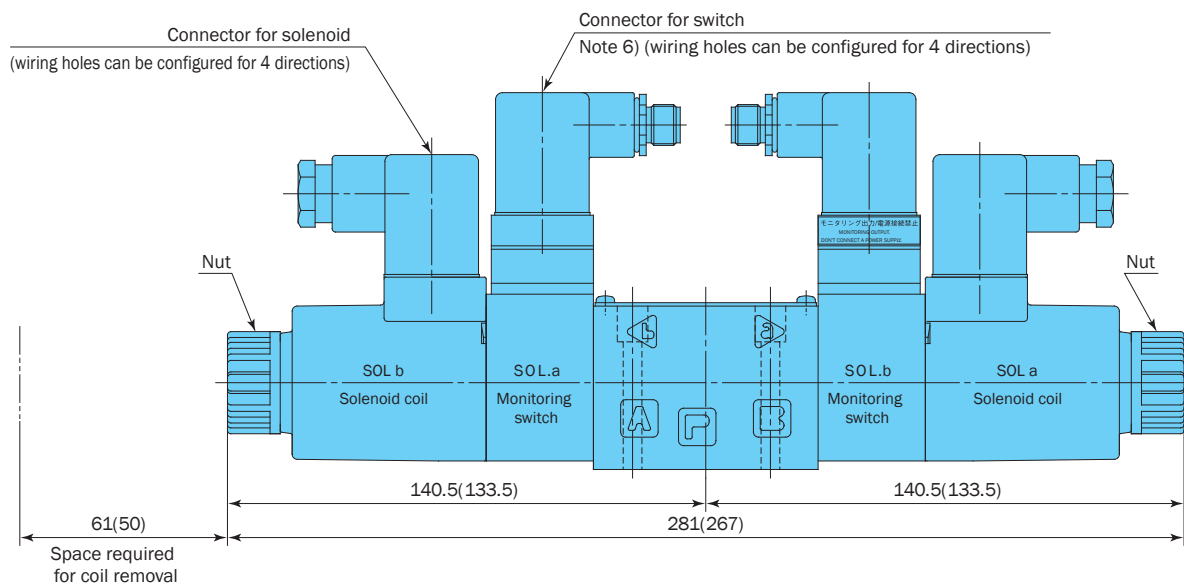

- Note:
1. Dimensions in parentheses apply in the case of an AC solenoid.
 2. For option symbol D (with cap to prevent manual operation), the nut for fixing coil is 5mm long. Include this length when calculating the total length of the valve.
 3. The connector for the switch in the drawing above is the M12-4 pin connector. In addition there are wire connections also. See page D-67 for more detailed information.
 4. The wiring hole for the connector is oriented as shown in the diagram for packaging purposes. The orientation can be changed according to the direction of the wiring.
 5. Use surgeless directional control valves with monitoring switches for all electric valves on the same machine to prevent misoperation of the monitoring switch caused by noise when the solenoid turns on and off.
 6. To orient the wiring hole for the connector for the switch towards the solenoid coil, loosen the nut and rotate the solenoid coil so the connector for the switch does not interfere with the connector for the solenoid.

• Details about the Connector for the Switch

(1) With wiring (option symbol: none)

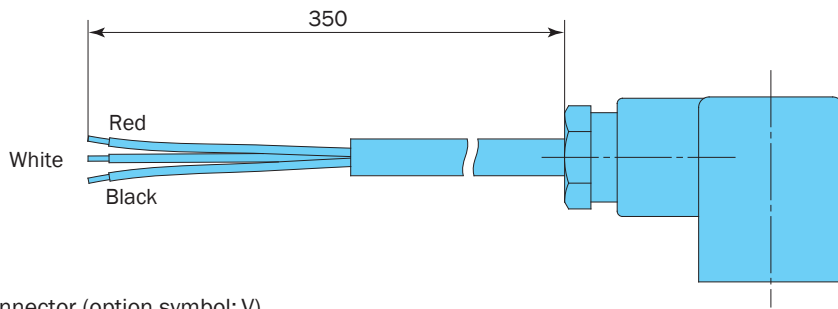

(2) With M12-4 pin connector (option symbol: V)

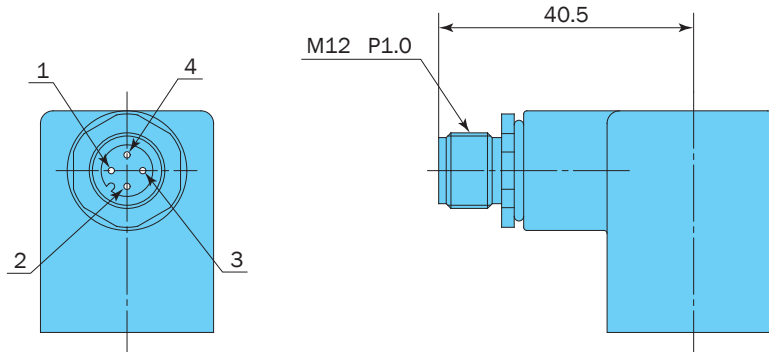

- Note: 1. The pin connector is screwed to the housing so it is rotated a certain amount compared to the drawing. Refer to the electrical circuit diagram below for how to connect it.
 2. The connector that the M12-4 pin connector connects to is not provided.
 (Example of connector with cable provided by customer: Omron XS2F-D421-D80-A)

(3) Electrical circuit diagram

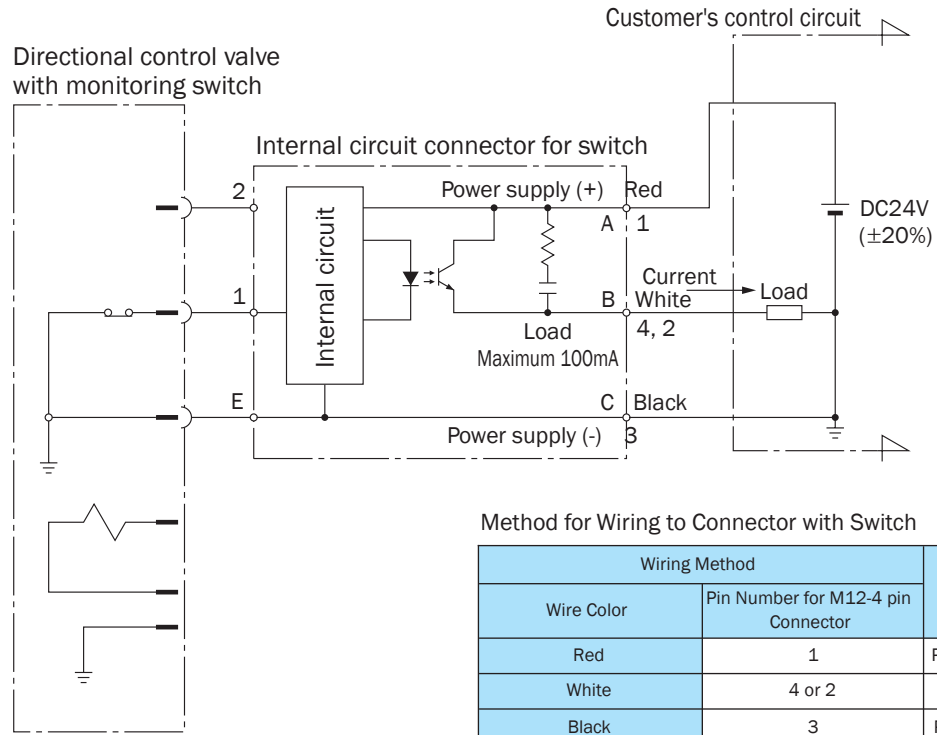

- Note: 3. Always install a diode to prevent surges in the current when connecting an inductive load, such as a relay, to the monitoring switch.
 4. Do not modify or replace the lead wires.
 5. Connect the load for the M12-4 pin connector to either pin number 4 or 2.
 6. When connecting monitoring switches in sequence, use the negative (-) common mode (type that current runs to sequence side).

Performance Curves

Hydraulic Operating Fluid Viscosity 32 centistokes

Pressure Loss Characteristics

Operation Symbol	P → A	P → B	A → T	B → T
A2X	c	c	—	—
A3X	b	b	b	b
A5	—	b	b	—
C1	b	b	a	b
C5	b	b	b	b
C6	b	b	a	a
C1S	b	b	b	b
C6S	b	b	b	b

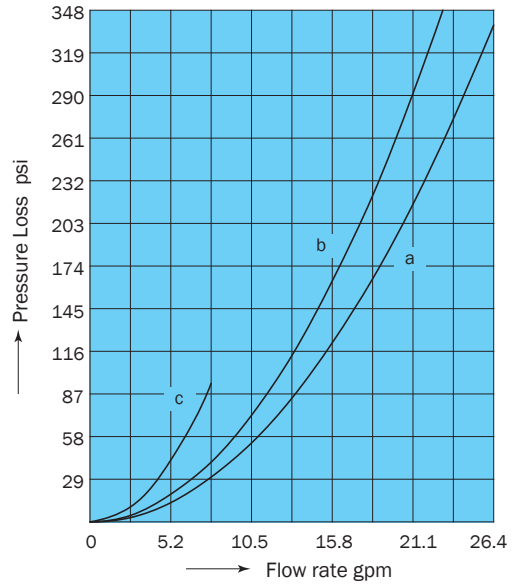

Pressure – Flow Volume Allowable Value

Operation Symbol	Standard Form, with AC, DC solenoid		
A2X	—	f	f
A3X	b	f	f
A5	a	—	e
C1	AC SOL. d DC SOL. c	e	e
C5	a	e	e
C6	AC SOL. d DC SOL. c	e	e
C1S	a	e	e
C6S	a	e	e

Operation Symbol	Shockless Type, with DC solenoid		
A2X	—	c	c
A3X	a	c	c
A5	a	—	c
C1	b	c	c
C5	a	c	c
C6	b	c	c
C1S	a	c	c
C6S	a	c	c

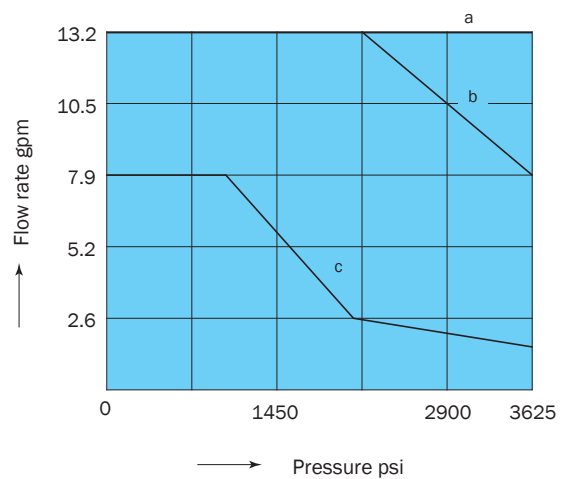
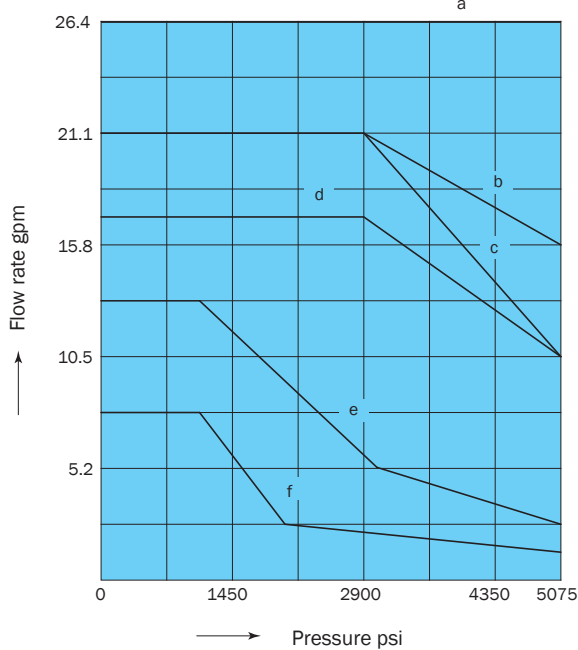

Range of Motion of Switch

Positions		Stroke of Spool		
		SOL.b ON	Center	SOL.a ON
Flow Path				
Motion of Switch	SOL.b Monitoring Switch	OFF	ON	
	SOL.a Monitoring Switch	ON		OFF

Note: 1. Flow path is C5 type (all-port-block), other flow paths also activate switch in middle position.
 2. ON and OFF indicate the state of the output transistor on the circuit board in the connector.

Switching Responsiveness

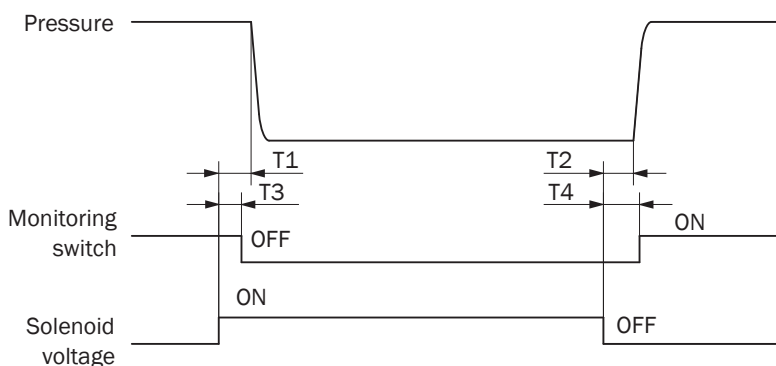

Type of Machine	Model	Response Time (s)				
		Pressure		Switch		
		T1	T2	T3	T4	
AC Solenoid	SAW-G01-C5-GR-C1-10	0.02 to 0.03	0.02 to 0.03	0.01 to T1	T2 to 0.05	
DC Solenoid	Standard Type	SAW-G01-C5-GR-D2-10	0.03 to 0.04	0.02 to 0.04	0.01 to T1	T2 to 0.06
	Built-in Rectifier	SAW-G01-E1-10	0.03 to 0.04	0.07 to 0.10	0.01 to T1	T2 to 0.15
	Shockless Type	SAW-G01-C5-FGR-D2-10	0.07 to 0.10	0.04 to 0.07	0.02 to T1	T2 to 0.10
	Built-in Rectifier Type Shockless Type	SAW-G01-C5-F-E1-10	0.07 to 0.10	0.10 to 0.15	0.02 to T1	T2 to 0.20

Note: May vary depending on switching response time and operating conditions (pressure, flow rate, and oil temperature).

[Measurement Conditions]

- Pressure 2030 psi
- Flow Rate 7.9 gpm
- Operating fluid ISO VG32 104° F

Cross-sectional Drawings

SAW-G01-A**-**-10

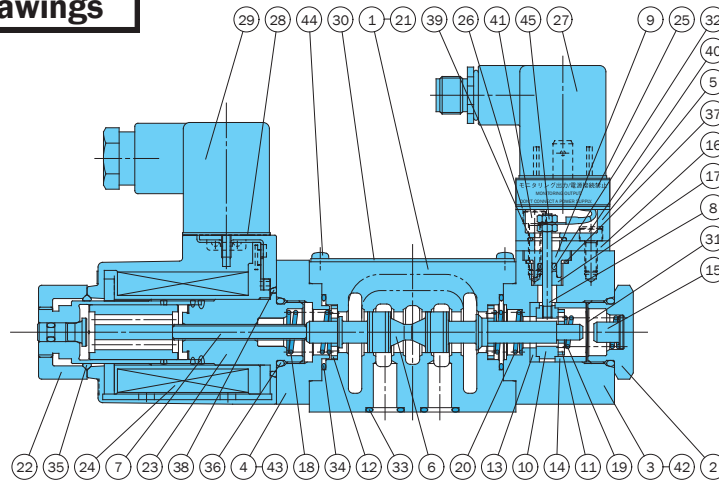

Part No.	Part Name	Part No.	Part Name	Part No.	Part Name
1	Body	16	Plate (connector)	31	Wave washer
2	Plug	17	Collar (insulated)	32	O-ring *
3	Cover (switch)	18	Spring (one SOL. guide side)	33	O-ring *
4	Cover (one SOL.)	19	Spring (one SOL. contact side)	34	O-ring *
5	Cover (connector)	20	Spring (main unit)	35	O-ring *
6	Spool	21	Spacer	36	O-ring *
7	Rod (guide)	22	Nut	37	O-ring *
8	Rod (conductor)	23	Solenoid guide	38	O-ring *
9	Bush (insulated)	24	Solenoid coil	39	O-ring *
10	Retainer (fixed contact)	25	Connector with lead wire	40	Hexagon socket head bolt
11	Retainer (movable contact)	26	Packing	41	Hexagon socket head bolt
12	Retainer (main unit)	27	Connector with built-in photo-coupler	42	Hexagon socket head bolt
13	Ring (insulation inside)	28	Connector packing	43	Hexagon socket head bolt
14	Ring (insulation outside)	29	Connector	44	Philips pan head screw
15	Stopper	30	Nameplate	45	Hexagon nut

Seal Part List (Kit Model Number EQS-01A)

Part No.	Part Name	Part Number	Q'ty
32	O-ring	1B-P3	1
33	O-ring	AS568-012 (Hs90)	4
34	O-ring	AS568-019 (Hs90)	2
35	O-ring	1A-P20	1
36	O-ring	1B-P18	2
37	O-ring	S-11.2 (Hs90)	1
38	O-ring	S25 (Hs70)	1
39	O-ring	S-9 (Hs70)	1

Note: 1A and 1B are JIS Standard B 2401, while AS568 is SAE standard.

For details about parts marked with an asterisk "**", refer to the list of seals in the table on the right.

SAW-G01-C**-**-10

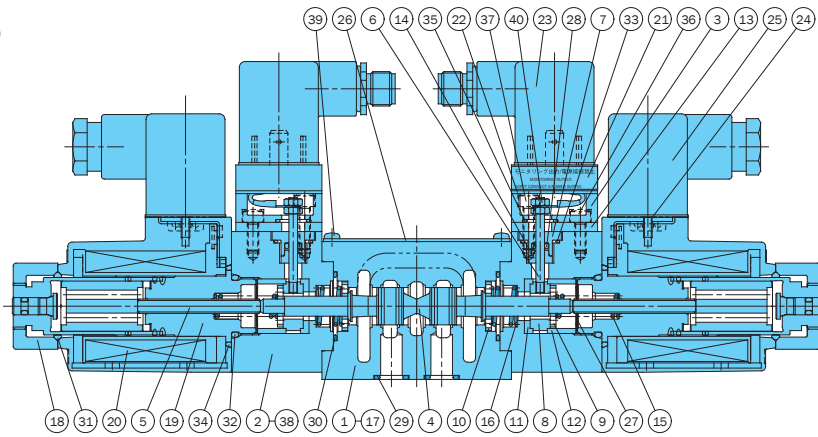

Part No.	Part Name	Part No.	Part Name	Part No.	Part Name
1	Body	16	Spring (main unit)	31	O-ring *
2	Cover (sensor)	17	Spacer	32	O-ring *
3	Cover (connector)	18	Nut	33	O-ring *
4	Spool	19	Solenoid guide	34	O-ring *
5	Rod (DC guide)	20	Solenoid coil	35	O-ring *
6	Rod (conductor)	21	Connector with lead wire	36	Hexagon socket head bolt
7	Bush (insulated)	22	Packing	37	Hexagon socket head bolt
8	Retainer (fixed contact)	23	Connector with built-in photo-coupler	38	Hexagon socket head bolt
9	Retainer (movable contact)	24	Connector packing	39	Philips pan head screw
10	Retainer (main unit)	25	Connector	40	Hexagon nut
11	Ring (insulation inside)	26	Nameplate		
12	Ring (insulation outside)	27	Wave washer		
13	Plate (connector)	28	O-ring *		
14	Collar (insulated)	29	O-ring *		
15	Spring (one SOL. contact side)	30	O-ring *		

Seal Part List (Kit Model Number EQS-01C)

Part No.	Part Name	Part Number	Q'ty
28	O-ring	1B-P3	2
29	O-ring	AS568-012 (Hs90)	4
30	O-ring	AS568-019 (Hs90)	2
31	O-ring	1A-P20	2
32	O-ring	1B-P18	2
33	O-ring	S-11.2 (Hs90)	2
34	O-ring	S-25 (Hs70)	2
35	O-ring	S-9 (Hs70)	2

Note: 1A and 1B are JIS Standard B 2401, while AS568 is SAE standard.

For details about parts marked with an asterisk "**", refer to the list of seals in the table on the right.