



**Direct Relief Modular Valve**

**5.2 to 13.2 gpm**  
**115 to 3045, 3625, 5075 psi**

**Features**

- 1 This modular relief valve provides maximum pressure control for a hydraulic circuit.
- 2 Wide ranging applicability Maximum Working Pressure: 3625, 5075 psi.
- 3 Pressure Adjustment Range: 115 to 3045, 3625, 5075 psi.

**Specifications**

Model No.	Nominal Diameter (Size)	Maximum Working Pressure psi	Maximum Flow Rate gpm	Pressure Adjustment Range psi	Weight lbs	Gasket Surface Dimensions
ORD-G01-W1-20 W3	1/8	3625	5.2	115 to 1000 500 to 3045	3.3	ISO 4401-03-02-0-94
ORD-G01-A1-20 A3				115 to 1000 500 to 3045	3.0	
ORD-G01-B1-20 B3				115 to 1000 500 to 3045	3.0	
ORD-G03-W1-J50 W3	3/8	3625	7.9	115 to 1000 500 to 3625	10.5	ISO 4401-05-04-0-94
ORD-G03-A1-J50 A3				115 to 1000 500 to 3625	8.8	
ORD-G03-B1-J50 B3				115 to 1000 500 to 3625	8.8	
ORH-G04-DW1-10 DW3 DW5	1/2	5075	13.2	115 to 1000 500 to 3625 1000 to 5075	14.3	ISO 4401-07-06-0-94
ORH-G04-DA1-10 DA3 DA5				115 to 1000 500 to 3625 1000 to 5075	14.3	
ORH-G04-DB1-10 DB3 DB5				115 to 1000 500 to 3625 1000 to 5075	14.3	

• Handling

- 1 The pressure adjustment range is expressed using cracking pressure.
- 2 For use as a safety valve, use a pressure override that is higher than the required circuit pressure.
- 3 Tank port back pressure changes cracking pressure by the corresponding amount.
- 4 Note that a sub plate and installation bolts are not included. See pages H4 and F87-89 if these items are required.
- 5 04 series modular valves do not have an L (DR2) drain port, so they cannot be used in combination with pressure center type solenoid valves (D).

**Understanding Model Numbers**

01, 03 size

**ORD - G 03 - W 3 - (K) - J50**

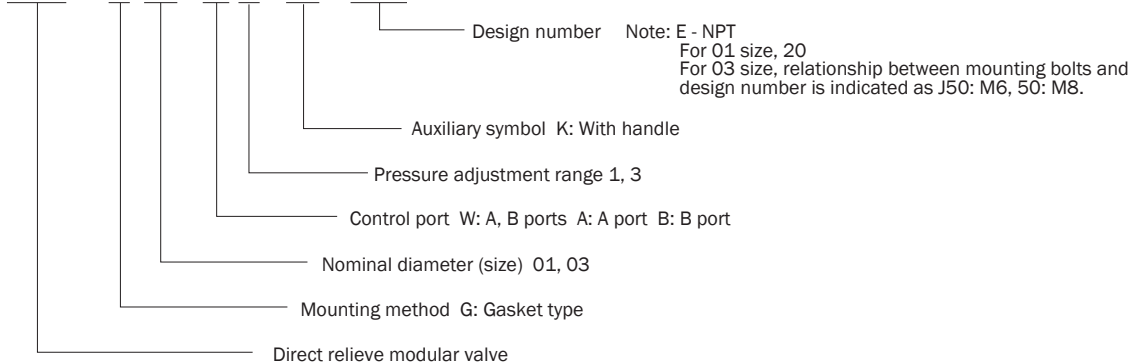

## Understanding Model Numbers

04 size

**ORH - G 04 - D W 5 - 10**

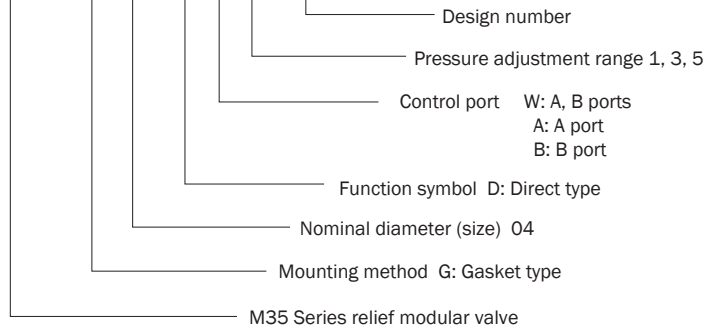

## Understanding Model Numbers

Note: Pressure is increased by clockwise (rightward) rotation of the adjusting screw (bolt), and decreased by counterclockwise (leftward) rotation

**ORD-G01-W\*-20**

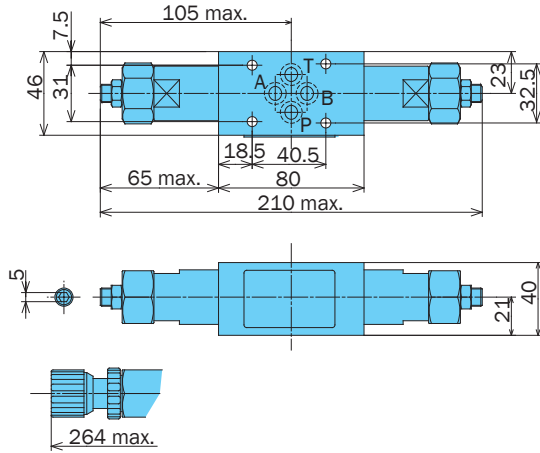

**ORD-G01-A\*-20**

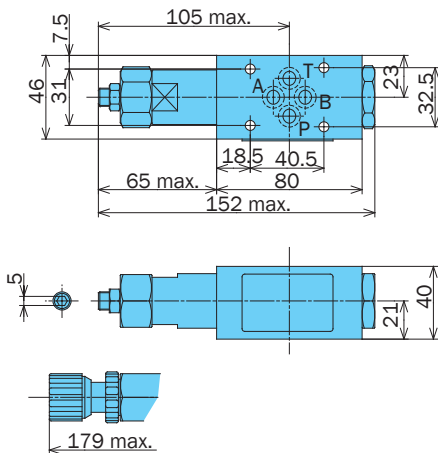

**ORD-G01-B\*-20**

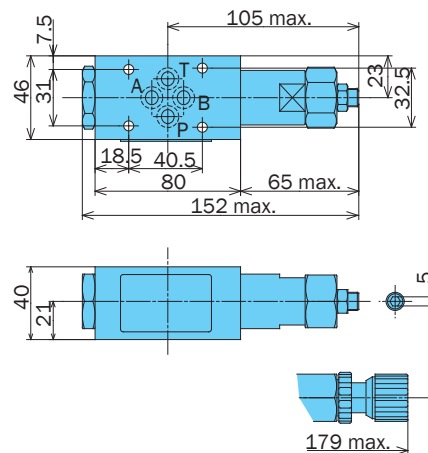

**ORD-G03-W\*-J50**

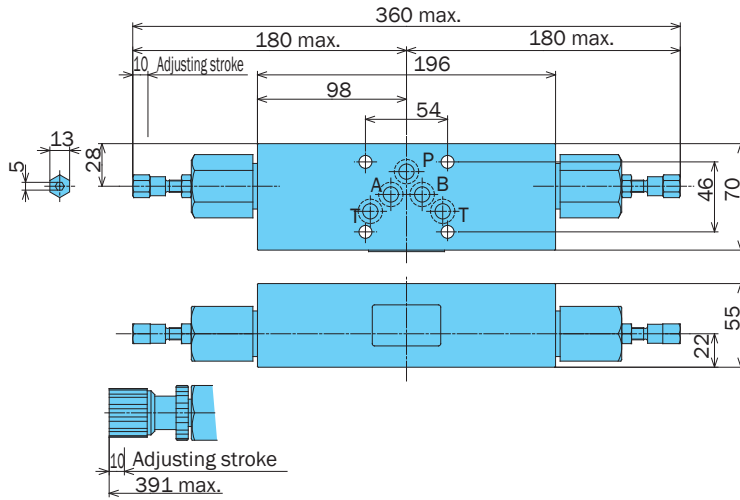

**ORD-G03-A\*-E50**

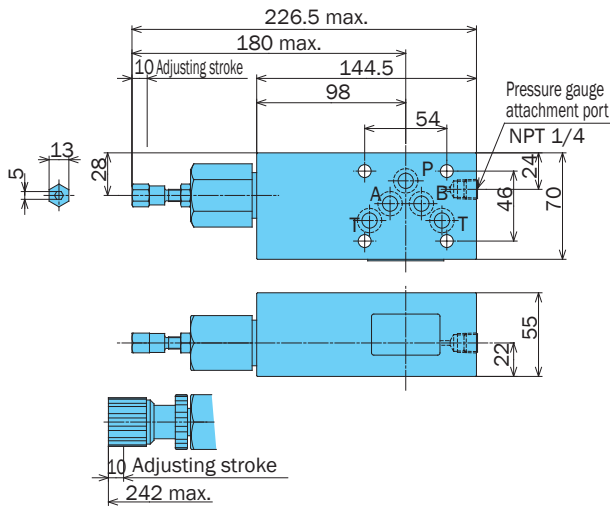

**ORD-G03-B\*-E50**

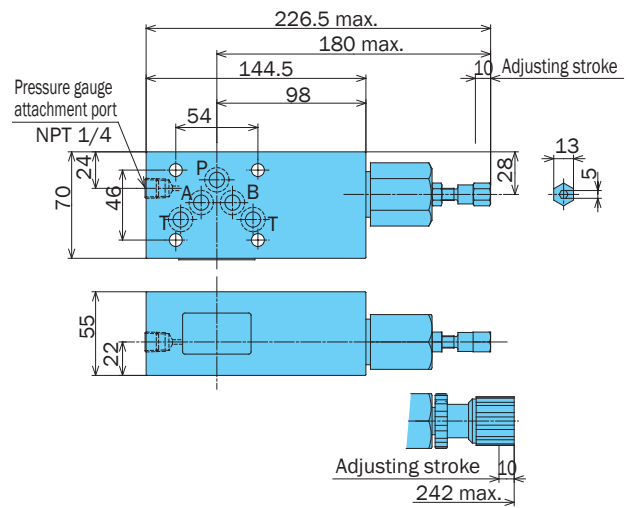

**ORH-G04-DW\*-10**

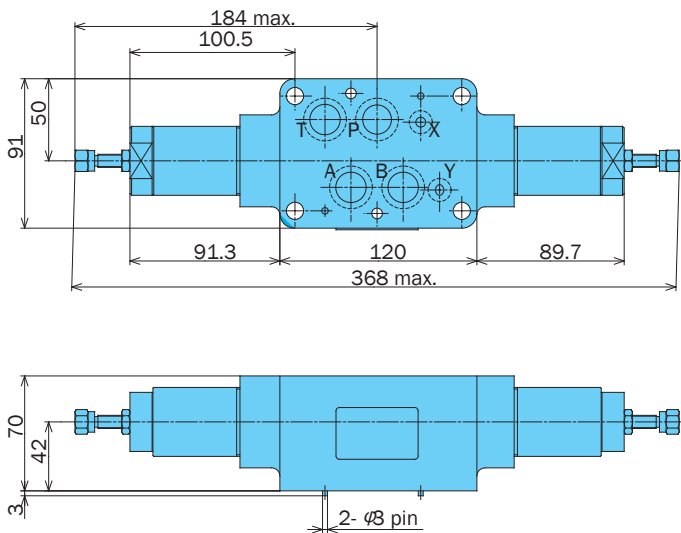

**ORH-G04-DA\*-10**

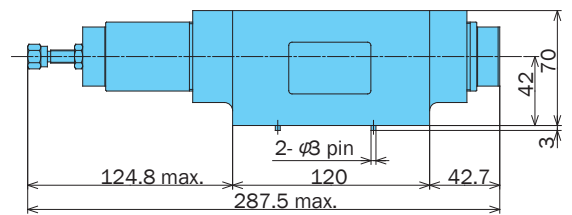

**ORH-G04-DB\*-10**

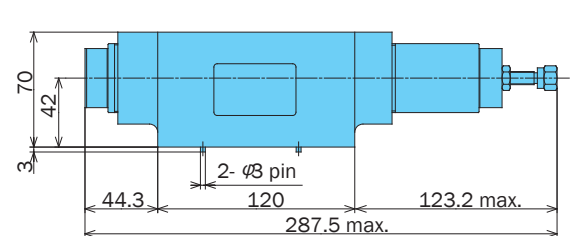

## Performance Curves

Differential Hydraulic Fluid Viscosity 32 centistokes

### Pressure - Flow Rate Characteristics

ORD-G01-\*\*-20

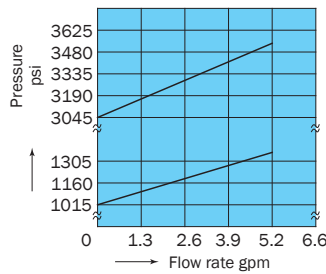

ORD-G03-\*\*-J50

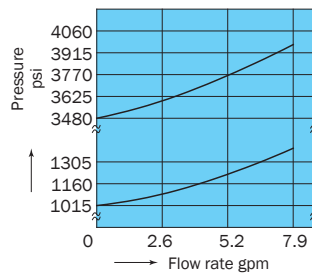

ORH-G04-DW\*-10

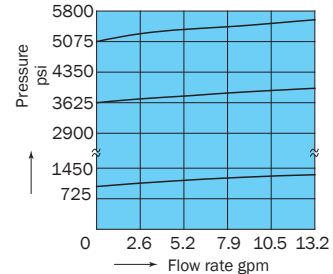

### Number of Adjusting Screw Rotations - Pressure Characteristics

ORD-G01-\*\*-20

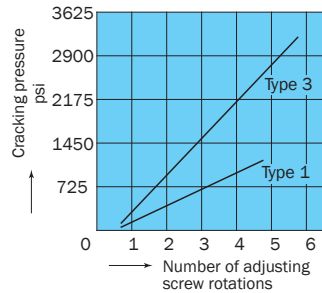

ORD-G03-\*\*-J50

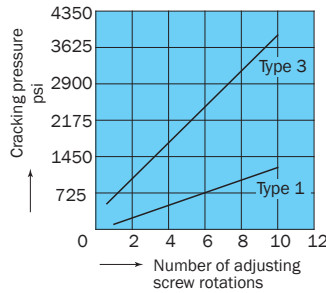

ORH-G04-DW\*-10

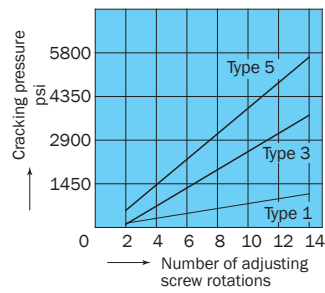

## Cross-sectional Drawing

ORD-G01-A\*-20

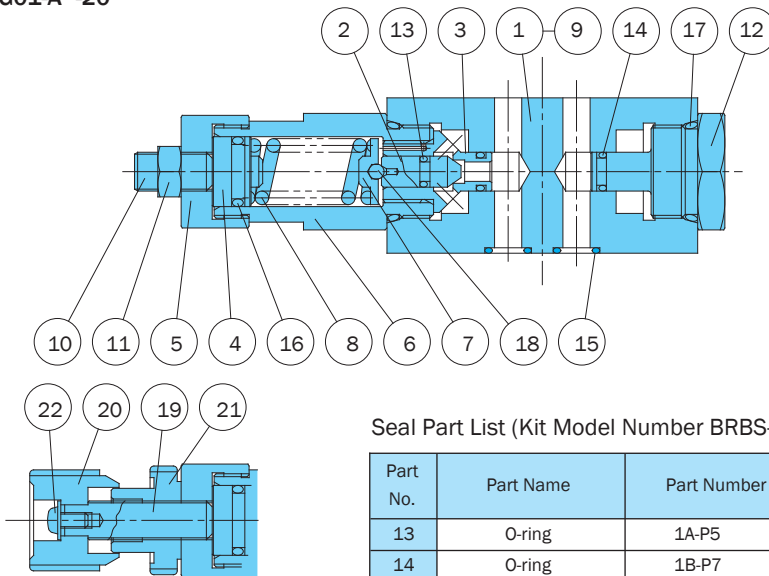

Seal Part List (Kit Model Number BRBS-01RD\*)

Part No.	Part Name	Part Number	Q'ty		
			W	A	B
13	O-ring	1A-P5	2	1	1
14	O-ring	1B-P7	2	2	2
15	O-ring	1B-P9	4	4	4
16	O-ring	1B-P14	2	1	1
17	O-ring	1B-P22	2	2	2

Note: 1.O-ring 1A/B-\*\*- refers to JIS B2401-1A/B.  
2.Specify W, A, or B for the asterisk (\*) in the kit model number.

Part No.	Part Name
1	Body
2	Poppet
3	Seat
4	Plunger
5	Bushing
6	Retainer
7	Guide
8	Spring
9	Plate
10	Screw
11	Nut
12	Bushing
13	O-ring
14	O-ring
15	O-ring
16	O-ring
17	O-ring
18	Ball
19	Screw
20	Knob
21	Nut
22	Screw

ORD-G03-A\*-J50

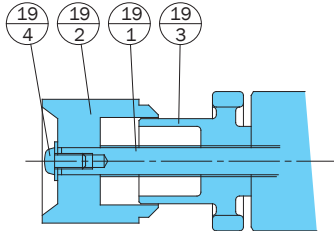
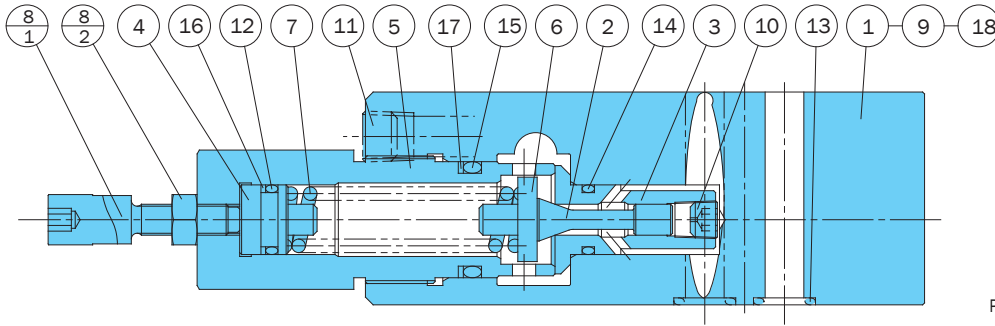

Seal Part List (Kit Model Number BRES-03RD\*)

Part No.	Part Name	Part Number	Q'ty		
			A	B	W
12	O-ring	1A-P14	1	1	2
13	O-ring	AS568-014(Hs90)	5	5	5
14	O-ring	1B-P14	1	1	2
15	O-ring	1B-P24	1	1	2
16	Backup ring	T2-P14	1	1	2
17	Backup ring	T2-P24	1	1	2

Note) 1.O-ring 1A/B-\*\* refers to JIS B2401-1A/B.  
 2.Backup ring indicates JIS B2407-T2-\*\*.  
 3.Specify W, A, or B for the asterisk (\*) in the kit model number

Part No. | Part Name

1	Body
2	Poppet
3	Seat
4	Plunger
5	Retainer
6	Guide
7	Spring
8	Screw kit
8 <sub>1</sub>	Screw
8 <sub>2</sub>	Nut
9	Plate
10	Orifice
11	Plug
12	O-ring
13	O-ring
14	O-ring
15	O-ring
16	Backup ring
17	Backup ring
18	Pin
19	Handle kit
19 <sub>1</sub>	Screw
19 <sub>2</sub>	Knob
19 <sub>3</sub>	Nut
19 <sub>4</sub>	Screw

ORH-G04-DA\*-10

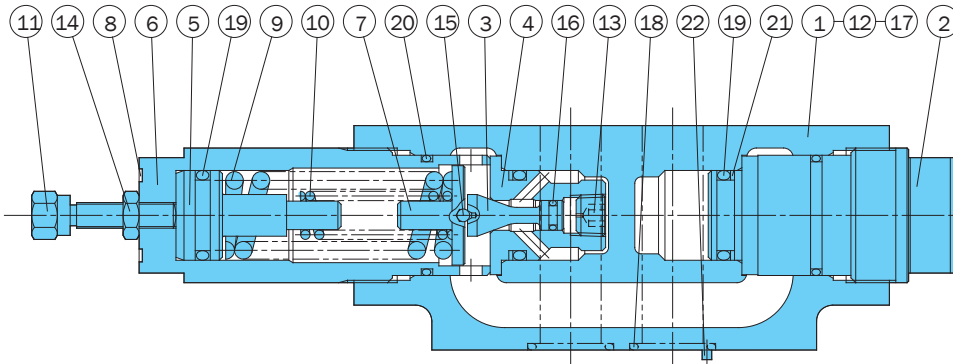

Seal Part List (Kit Model Number BRKS-04RD\*)

Part No.	Part Name	Part Number	Q'ty		
			W	A	B
16	O-ring	1A-P6	2	1	1
17	O-ring	AS568-012(Hs90)	2	2	2
18	O-ring	AS568-118(Hs90)	4	4	4
19	O-ring	1B-P22A	4	3	3
20	O-ring	AS568-125(Hs70)	2	2	2
21	Backup ring	T2-P22A	2	2	2

Note) 1.O-ring 1A/B-\*\* refers to JIS B2401-1A/B.  
 2.Backup ring indicates JIS B2407-T2-\*\*.  
 3.Specify W, A, or B for the asterisk (\*) in the kit model number.

Part No. | Part Name

1	Body
2	Plug
3	Poppet
4	Seat
5	Plunger
6	Retainer
7	Guide
8	Plate
9	Spring
10	Spring
11	Screw
12	Plate
13	Choke
14	Nut
15	Ball
16	O-ring
17	O-ring
18	O-ring
19	O-ring
20	O-ring
21	Backup ring
22	Pin