

VDS Series Small Variable Volume Vane Pump

0.5 in³/rev
3.94 gpm
1015 psi

Features

High efficiency operation with minimal power loss

All the performance of the original new VDR series mechanisms combines with precision machining for a pump that minimizes power loss, especially at full cutoff.

Quiet operation

Journal bearings with a proven record on IP pumps plus new suction and discharge port configurations reduce operating noise and deliver quiet

operation with minimal vibration, even in the high-pressure range.

Compact and simple design, easy operation

Compact and quiet, VDS Series variable vane pumps are economical and easy to handle. A simple design allows use in a wide range of hydraulic systems.

Precise characteristics, prompt response

Prompt response at both ON-OFF

and OFF-ON ensures instantaneous, stable, high-precision operation.

Solidly built for high efficiency and long life

VDS Series pumps are built to last, with a design that incorporates years of NACHI experience and know-how. Specially selected materials and skilled workmanship provide outstanding durability along with stable, high-efficiency operation.

www.khadamathydraulic.com
Tel: 021-55882749
Tel: 021-33488178
Fax: 021-33488105

Specifications

Model No.	Capacity in ³ /rev	No-load Discharge Rate gpm				Pressure Adjustment Range psi	Allowable Peak Pressure psi	Revolution Speed min ⁻¹		Weight lbs
		1000min ⁻¹	1200min ⁻¹	1500min ⁻¹	1800min ⁻¹			Min.	Max.	
VDS-0A(B)-1A1-E11						145 ~ 290				
" -1A2-E11	.50	2.1	2.6	3.2	3.94	317 ~ 507	2030	800	1800	A : 14.3 B : 9.9
" -1A3-E11						435 ~ 1015				

• Handling

- The direction of rotation for this pump is clockwise (rightward) when viewed from the shaft side.
- Drain piping must be direct piping up to a point that is below the tank fluid level, and back pressure due to pipe resistance should not exceed 4.3 psi.
- When adjusting pressure, pressure is increased by clockwise (rightward) rotation of the adjusting screw and decreased by counterclockwise (leftward) rotation.
- When adjusting the flow rate, the flow rate is decreased by clockwise (rightward) rotation of the adjusting screw and increased by counterclockwise (leftward) rotation. The graph on the right provides general guidelines for the relationship between the rotation angle of the flow rate adjusting screw and the no-load discharge rate.
- Factory Default P-Q Settings (Standard Model)
 - Flow Rate Setting = Maximum flow rate for model as indicated in the catalog.
 - Pressure Setting = Pressure shown in table below.

Factory Default Pressure Settings kgf/cm ² (psi)	
1	: 20.4 (290)
2	: 35.7 (507)
3	: 71.4 (1015)

$$\text{Flow rate gpm} = \frac{\text{in}^3 \times \text{rpm}}{231}$$

Q: No-load Discharge Rate (gpm)
q: Capacity (in³/rev)

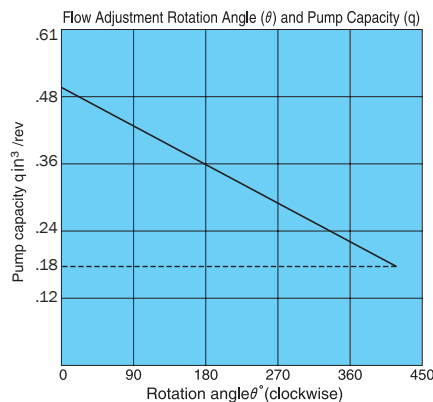

The values indicated above are at maximum pump discharge volume with the flow volume adjusting screw at the 0° position. The broken line shows the flow volume adjustment range lower limit value.

6 Thrust Screw

The thrust screw is precision adjusted at the factory during assembly. Never touch the thrust screw.

See callout 9 in the cross-section diagram on page B-4.

7 Initial Operation

Before operating the pump for the first time, put the pump discharge side into the no-load state and then repeatedly start and stop the motor to bleed all air from inside the pump and the suction piping. After confirming that the pump is discharging oil, continue the no-load operation for at least 10 minutes to discharge all the air from the circuit.

8 For the hydraulic operating fluid, use an R&O type and wear-resistant type of ISO VG32 to 68 or equivalent (viscosity index of at least 90). Use hydraulic operating fluid that provides kinematic viscosity during operation in the range of 20 to 150 centistokes.

9 The operating temperature range is 59 to 140 °F. When the oil temperature at startup is 59 °F or less, perform a warm-up operation at low pressure until the oil temperature reaches 59 °F. Use the pump in an area where the temperature is within the range of 59 to 140 °F.

(continued on following page)

- 10 Suction pressure is 4.35 psi, and the suction port flow rate should be greater than 6 ft/sec.
- 11 Avoid pulley, gear, and other drive systems that impart a radial or thrust load on the end of the pump shaft. Mount the pump so its pump shaft is oriented horizontally.
- 12 Provide a suction strainer with a filtering grade of about 100 μm (150 mesh). For the return line to the tank, use a 10 μm line filter.

- 13 Manage hydraulic operating fluid so contamination is maintained at class NAS10 or lower. Take care to avoid contamination with water or other foreign matter, and watch for discoloration. Whitish fluid indicates that air has contaminated the fluid, and brownish fluid indicates the fluid is dirty.
- 14 Contact your agent about using water- and glycol-based hydraulic operating fluids.
- 15 At startup, repeat the inching operation

- (start-stop) to bleed air from the pump and pipes.
- 16 Equip an air bleed valve in circuits where it is difficult to bleed air before startup. See page C-13 for more information.
- 17 To ensure proper lubrication of the pump's rubbing surfaces, supply oil to the interior of the pump before starting operation.
- 18 When centering the pump shaft, eccentricity with the motor shaft should be no greater than 0.001 in. The angle error should be no greater than 1°.

Understanding Model Numbers

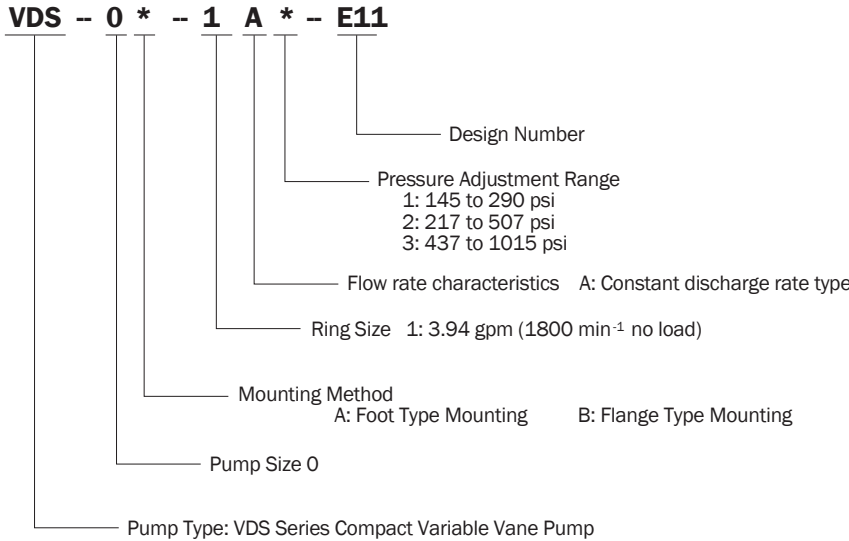

Installation Dimension Drawings

VDS-0A-1A-*-10

Foot Mounting Type mm (inch)

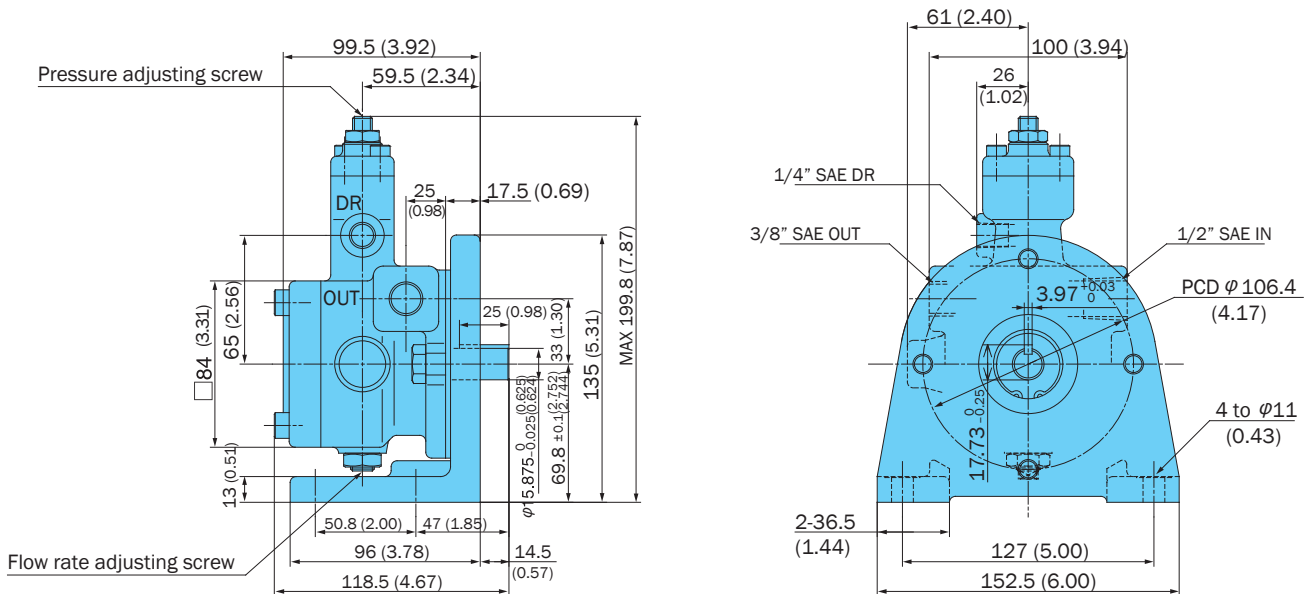

Note: Foot Mounting Kit: IHM-2-10

VDS-0B-1A-*-10

SAE A Mount

Flange Mounting

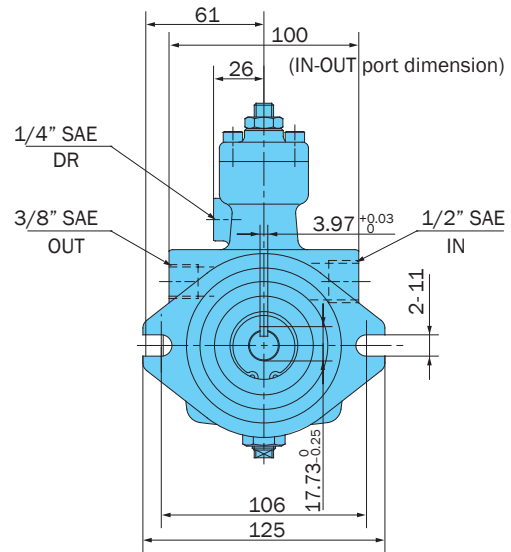
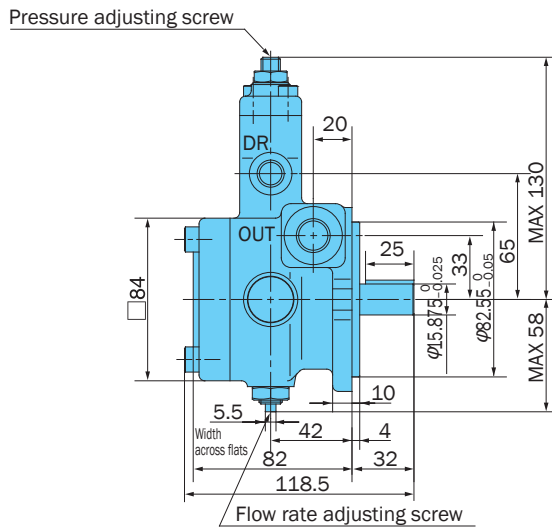

Specifications

Typical characteristics at hydraulic operating fluid kinematic viscosity of 32 centistokes

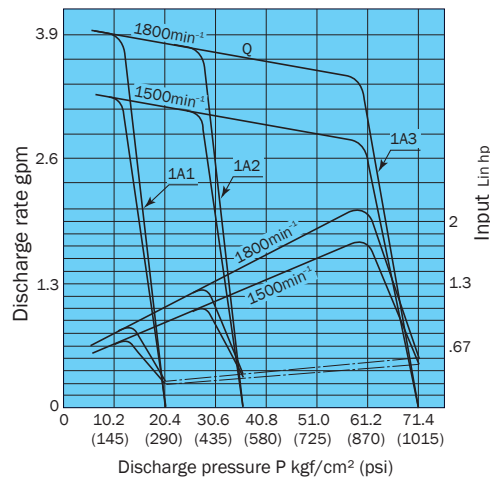

Axial Input at Full Cutoff

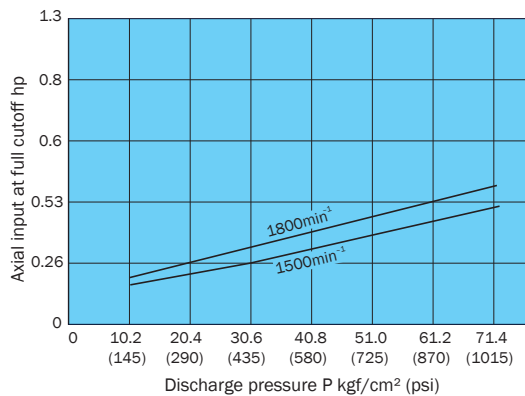

Noise Characteristics

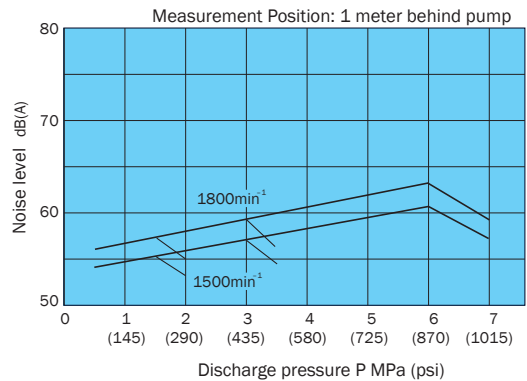

Cross-Sectional Drawing

VDS-0B-1A*-10

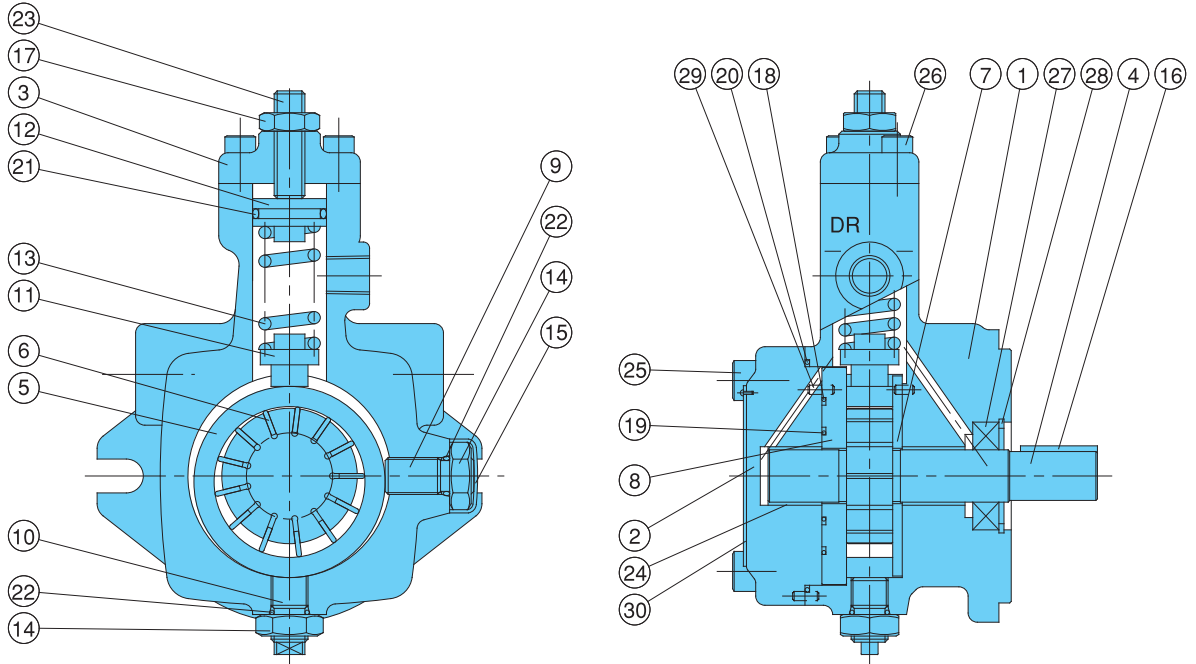

List of Sealing Parts

Seal Kit: VBAS-100B00

Applicable Pump Model: VDS-0A/B-1A *10

Part No.	Part Name	Part Number	Q'ty
18	O-ring	AS568-032	1
19	O-ring	AS568-023	1
20	O-ring	S71 (NOK)	1
21	O-ring	1A-P20	1
22	O-ring	1A-P10	2
27	Oil seal	TC-17358	1

Note:

1. Oil seals are manufactured by Nippon Oil Seal Industry Co. Ltd. (NOK).
2. O-ring 1A/B-** refers to JIS B2401-1A.

Part No.	Part Name	Part No.	Part Name
1	Body	16	Key
2	Cover (A)	17	Nut
3	Cover (B)	18	O-ring
4	Shaft	19	O-ring
5	Cam ring	20	O-ring
6	Vane	21	O-ring
7	Plate (S)	22	O-ring
8	Plate (H)	23	Screw
9	Thrust screw	24	Bearing
10	Screw	25	Screw
11	Piston	26	Screw
12	Holder	27	Oil seal
13	Spring	28	Snap ring
14	Nut	29	Pin
15	Cap	30	Nameplate

Uni-Pump Specifications

(CE mark standard compliant)

Understanding Model Numbers

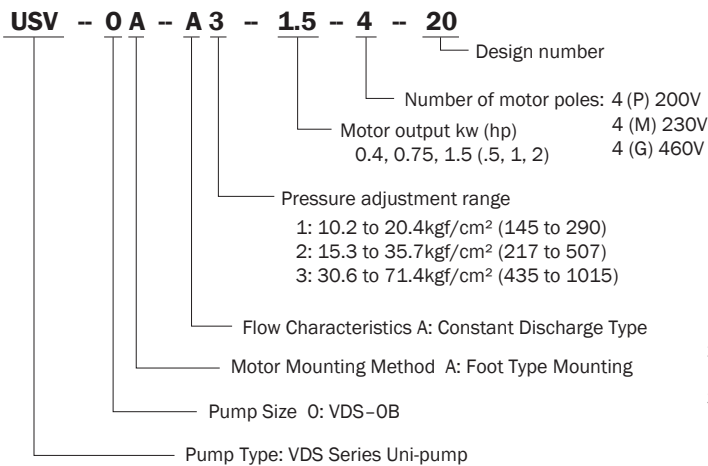

Cartridge Kit:
VBAC-100*A*

Includes Items: 4, 5, 6, 7, 8, 16, 29

Maximum Working Pressure kgf/cm (psi)	Maximum Flow Rate gpm	
	50Hz	60Hz
71.4 (1015)	3.30	3.94

1. Standard drive motor is the fully enclosed fan-cooled B type.
2. Standard voltage for drive motor is 200 VAC, 50/60 Hz or 220 VAC, 60 Hz.
3. Standard terminal box is B terminal (right side viewed from pump).

Motor Selection Curves

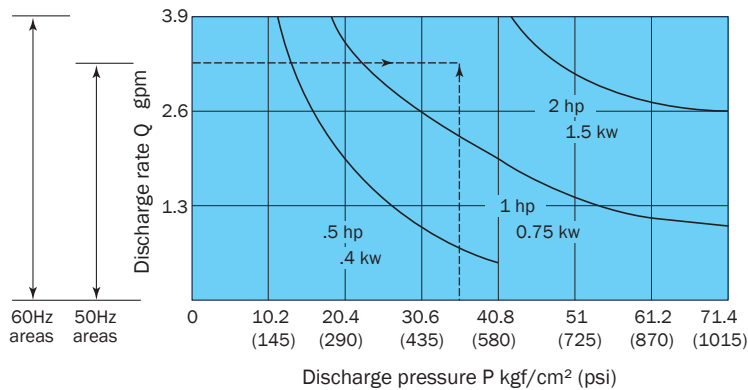

• How to select a motor

The area under a motor output curve in the graph to the left is the operating range for that motor under the rated output for that motor.

Example:

To find the motor that can produce pressure of 507 psi and a discharge rate of 3.3 gpm.

Selection Process:

Since the intersection of the two broken lines of a pressure of 507 psi and discharge rate of 3.3 gpm intersect in the area under the 2 hp curve, it means that a 2 hp motor should be used.

* Select a uni-pump that has a pressure and flow rate that is within the range of the drive so that the drive will not overload.

Installation Dimension Drawings

0.4
USV-0A-A* - 0.75-4-20
1.5

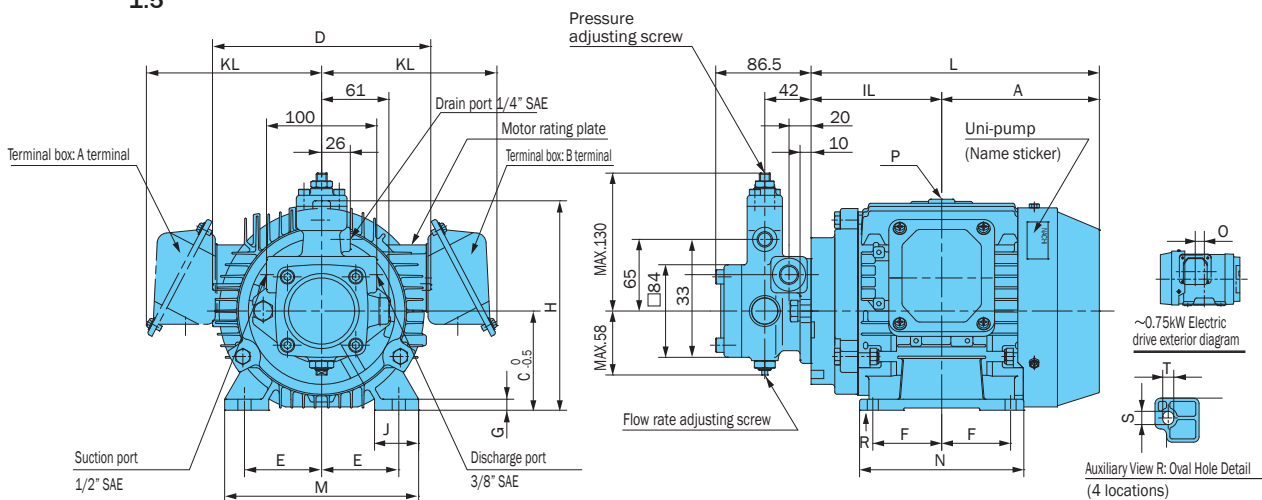

Uni-pump	Motor Dimensions mm																Frame No.	Output hp (4 poles)	Weight lbs
	A	IL	C	D	E	F	G	H	J	L	M	N	S × T	KD	KL	O			
USV-0A-A1-0.4-4-20	121	107.5	71	150	56	45	2.3	146	30	228.5	140	110	15 × 7	φ27	151	35	71M	0.5	30
USV-0A-A2-0.4-4-20																			
USV-0A-A3-0.4-4-20																			
USV-0A-A1-0.75-4-20	133	107.5	80	170	62.5	50	4.5	165	35	240.5	165	130	18 × 10	φ27	157	27.5	80M	1.0	42
USV-0A-A2-0.75-4-20																			
USV-0A-A3-0.75-4-20																			
USV-0A-A3-1.5-4-20	143	118.5	90	198	70	62.5	10	190	40	261.5	176	150	12 × 10	φ27	159	-	90L	2	45

* See page A-21 for the characteristics of the drive motor for the unipump (domestic standard 3 rating).