

Veljan Unloading Valves series VR4U are pilot operated controls and used to unload a circuit at low pressure when pilot pressure at port X is maintained higher than that of inlet pressure at port A set by the pilot spring. A typical use of an unloader valve is to unload the low pressure side of a double pump. A Pump connected to an Accumulator circuit can also be unloaded by the VR4U valve.

VR4U consists of a high flow poppet type seat valve section controlled by the low flow, adjustable pilot section mounted on top. Pressure setting is achieved by means of knurled knob. For tamper proof setting, acorn nut with lead seal is available as option. Optional vent valve VV01 sandwiched between pilot section and main body can be used for venting the VR4U valves.

Exceptionally fast response is obtained due to the precise ratio between the main piston area and its mass. One of the unique features of VR4U is that it works as a relief valve at the set pressure even in the absence of external pilot signal.

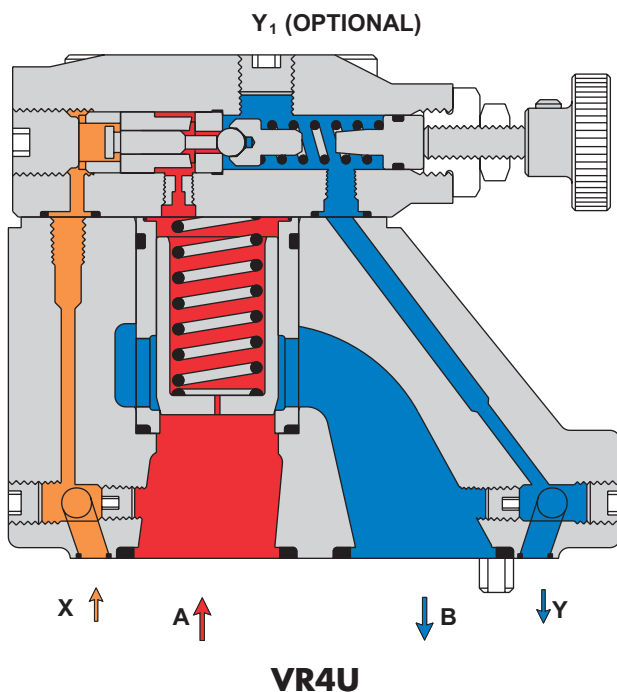
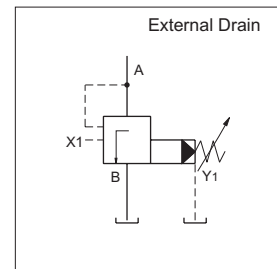
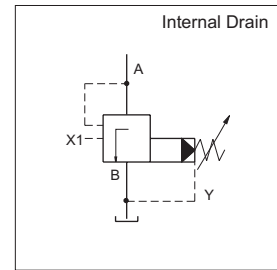

Normally port A is connected to pump and port B to tank. At low pressure, flow entering port A is blocked by the main poppet. Pressure from port A passes to the pilot section through orifices in the main poppet and in the pilot section. No flow takes place in this portion until the pressure overcomes the spring setting of a pilot ball. The pilot ball is lifted from its seat releasing a small pilot flow to tank and resulting in a pressure drop across the main poppet. The main poppet opens and allows only enough flow from port A to port B maintaining inlet pressure at the set value of the pilot spring as in the case of a relief valve.

In this condition, the external pilot pressure from another part of system if applied at port X causes a small override piston to act against the ball pushing it further off its seat resulting in very low pressure drop across the main poppet as long as pilot pressure is maintained, the main poppet opens further and unloads the inlet flow at very low pressure drop. As soon as the pilot pressure drops to approximately 10% below the pilot setting, the main poppet closes with a snap action diverting the main pump flow back to the hydraulic system. Excessive restriction in the tank line or the pilot pressure signal at port X should be avoided to attain a correct function.

SPECIFICATIONS

General

Type	:	Pilot operated Unloading Valve
Design	:	Poppet type
Mounting	:	Threaded/Subplate/Cartridge/Flange
Mounting position	:	Optional
Port sizes (nominal)	:	3/8", 3/4", 1 1/4"
Direction of flow	:	A→B
Ambient temperature	:	-20° C...+60° C (-4° F...+140° F)
Special working conditions	:	Consult VELJAN

Hydraulics

Pressure control range	:	Minimum - depends on flow Maximum - 5000 psi (350 bar)
Maximum operating pressure	:	
Port A (inlet)	:	5000 psi (350 bar)
Port B (outlet)	:	Internal pilot drain - 50 psi (3.5 bar) External pilot drain - 430 psi (30 bar)
Port X (pilot)	:	5000 psi (350 bar)
Port Y, Y1 (Pilot drain)	:	Without pressure to tank
Nominal flow gpm (lpm)	:	VR4U 03 (3/8") VR4U 06 (3/4") VR4U 10 (1 1/4") 15.8 (60) 52.9 (200) 119.0 (450)
Maximum flow gpm (lpm)	:	23.8 (90) 79.4 (300) 158.7 (600)
Fluid	:	Mineral oil as per DIN 51524/25 or other fluids on request
Fluid Temperature Range	:	-18° C...+80° C (0° F...+176° F)
Viscosity Range	:	10 to 650 cSt (60 to 3900 SSU)
Optimum operating viscosity	:	30 cSt (180 SSU)
Seal compatibility	:	Code 1 (Buna N) or Code 5 (Viton) (contact Veljan with specific oil details)
Cleanliness recommended	:	Better than NAS 1638 Class 8 or ISO 17/14

Adjustment

Manual	:	Handwheel
Rotation	:	3.75 rev.
Operating torque	:	0.72 Nm
Electricals (Vent Valve VVV01)	:	Solenoid
Nominal voltage	:	Refer to Ordering Code
Permissible voltage fluctuation	:	+5%...-10%
Max. coil temperature	:	+155° C (311° F)
Type of current	:	Alternating Current (AC)/Direct Current (DC)
Input power	:	31 W
Holding	:	78 VA
Inrush	:	264 VA
Relative operating period	:	100%
Type of protection	:	I P 65

ORDERING CODE

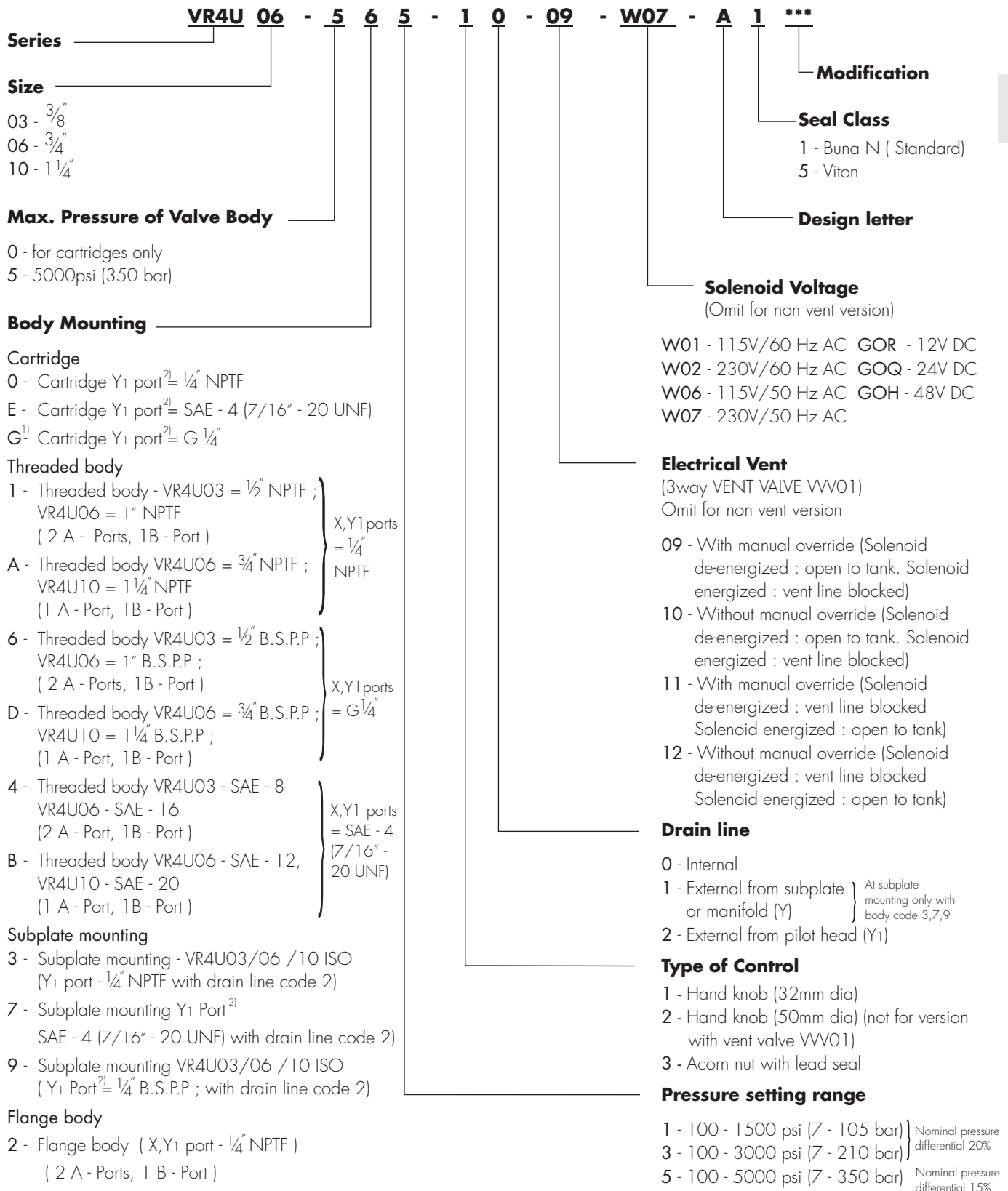

1) Only with Drain line code 2
 2) Port Y1 is only available at Drain line (code2) external from pilot head.

PERFORMANCE CURVES

Pressure Differential Characteristics

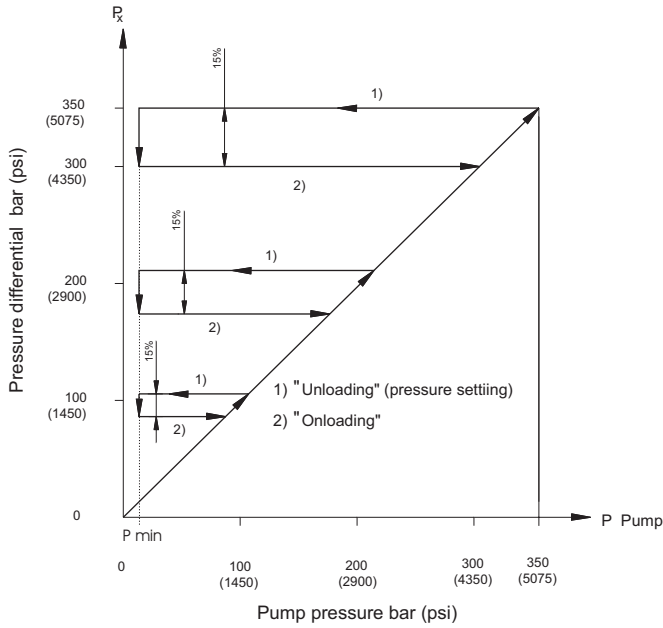

The differential between Unloading and Onloading is typical 15%. When system pressure (for instance accumulator) drops 15% below the pilot setting, the valve closes and pump feeds the system again.

$\Delta p - q_v$ - Characteristics

(Fluid 60 cSt at 40° C
Test temp. 50° C ± 10%)

Typical application systems

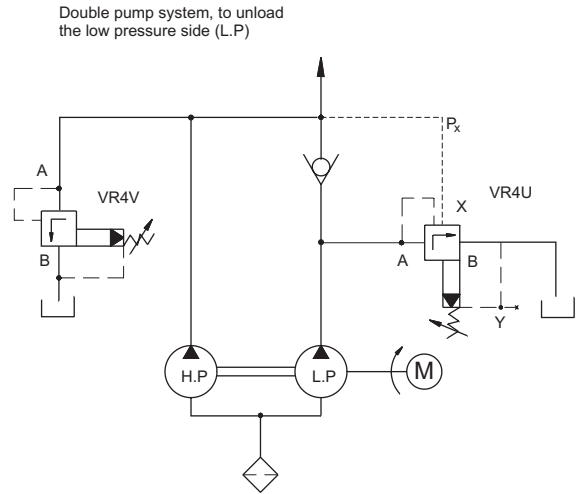

Accumulator system with unloading valve R4U

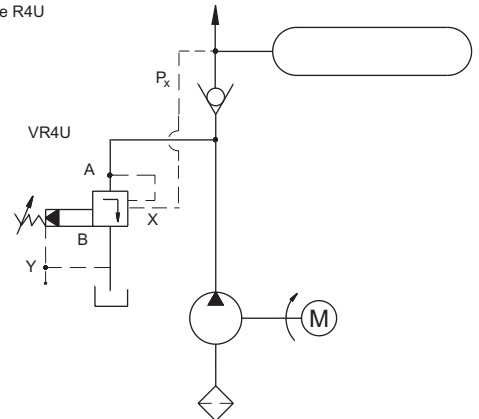

VR4U03

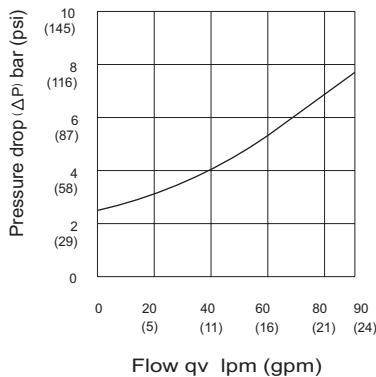

VR4U06

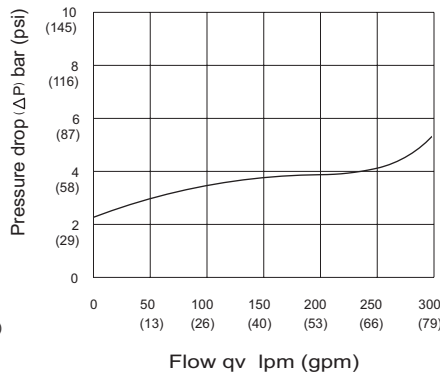

VR4U10

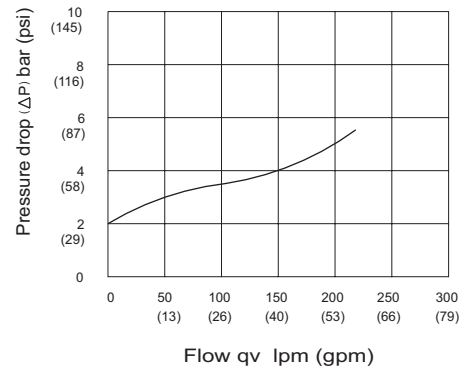

VR4U03 (3/8") SUBPLATE MOUNTING BODY (#3, #7 & #9)

Weight : 5.93 lbs (2.7 kg)

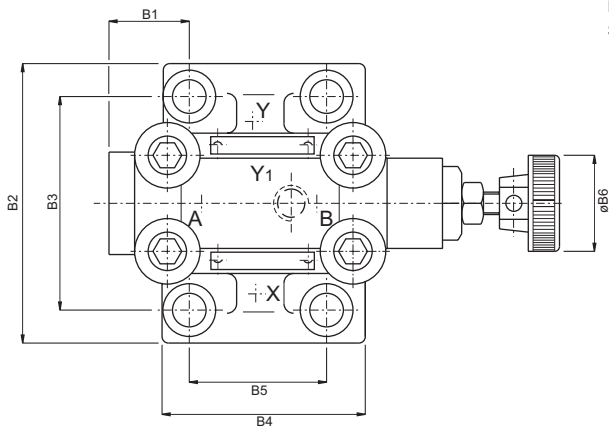
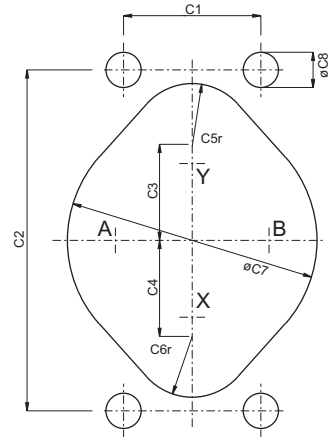
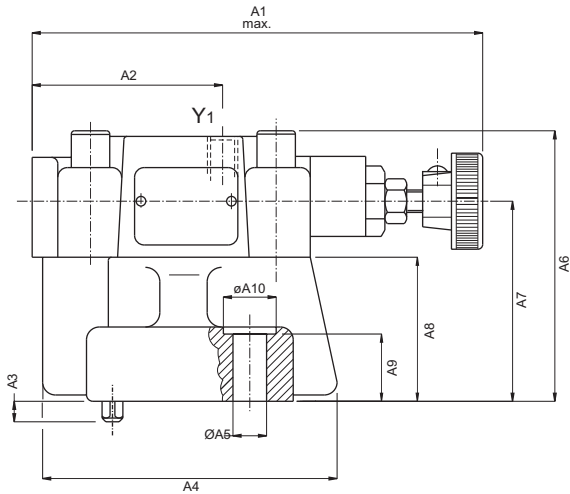

Block mounting face
Flatness 0.01 mm/100 mm length
Surface finish CLA 1.27 µm

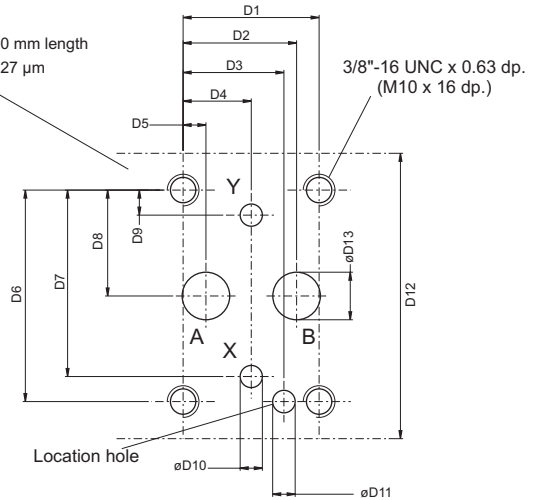

Dimensions	Dimensions	
	in	mm
A1	5.55	141.0
A2	2.34	59.5
A3	0.25	6.4
A4	3.622	92.0
A5	ø0.41	ø10.5
A6	3.33	84.5
A7	2.46	62.5
A8	1.77	45.0
A9	0.83	21.0
A10	ø0.65	ø16.5

Dimensions	Dimensions	
	in	mm
B1	1.14	29.0
B2	3.437	87.3
B3	2.626	66.7
B4	2.5	63.5
B5	1.69	42.9
B6	ø1.26	ø32.0

Dimensions	Dimensions	
	in	mm
C1	1.69	42.9
C2	4.19	106.5
C3	1.18	30.0
C4	1.18	30.0
C5	0.75 r	19.0 r
C6	0.75 r	19.0 r
C7	ø3.07	ø78.0
C8	ø0.43	ø11.0

Dimensions	Dimensions	
	in	mm
D1	1.69	42.9
D2	1.41	35.8
D3	1.253	31.8
D4	0.846	21.5
D5	0.283	7.2
D6	2.626	66.7
D7	2.315	58.8
D8	1.315	33.4
D9	0.311	7.9
D10	ø0.275	ø7.0
D11	ø0.28 x 0.315 dp.	ø7.1 x 8.0 dp.
D12	3.543	90.0
D13	ø0.59	ø15.0

Ports	Function
A	Pressure (inlet)
B	Tank (outlet)
X	Remote control or vent connection
Y(Y ₁)	External drain ¹⁾

1) Optional from pilot head or subplate.
Port Y₁ is only available at drain line (code 2) external from the pilot head.

VR4U03 (3/8") SUBPLATE

Weight : 4.4 lbs (2.0 kg)

PC

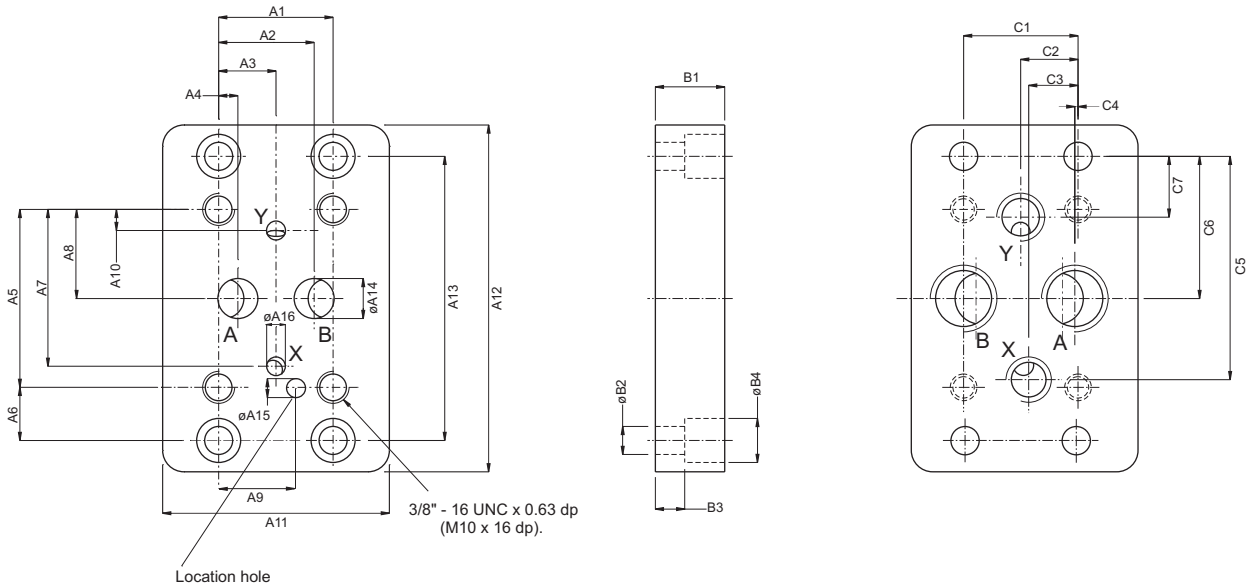

	Dimensions	
	in	mm
A1	1.69	42.9
A2	1.41	35.8
A3	0.846	21.5
A4	0.283	7.2
A5	2.626	66.7
A6	0.783	19.9
A7	2.315	58.8
A8	1.315	33.4
A9	1.25	31.8
A10	0.311	7.9
A11	3.346	85.0
A12	5.12	130.0
A13	4.19	106.5
A14	ø0.59	ø15.0
A15	ø0.28 x 0.315 dp.	ø7.1 x 8.0 dp.
A16	ø0.275	ø7.0

	Dimensions	
	in	mm
B1	1.024	26.0
B2	ø0.41	ø10.5
B3	0.433	11.0
B4	ø0.65	ø16.5

	Dimensions	
	in	mm
C1	1.69	42.9
C2	0.846	21.5
C3	0.73	18.5
C4	0.047	1.2
C5	3.295	83.7
C6	2.1	53.3
C7	0.9	22.8

Order No.	Port sizes		4 Mounting screws*		
	A+B	X+Y	Dimension	Order No.	min.tensile strength
VSS - P - 08 - G 112	1/2" NPTF	1/4" NPTF	3/8" - 16UNC 1 1/4 lg.	V358 - 16180	at p ≤ 210 bar = 100 daN/mm ² (Torque 68 Nm) at p > 210 bar = 120 daN/mm ² (Torque 82 Nm)
VSS - B - 08 - G 113	1/2" B.S.P.P	1/4" B.S.P.P.	M10 x 35mm DIN 912 - 12.9	V700 - 70039	

* Mounting screws are included in subplate order.
For valves ordered without subplate, mounting screws must be ordered separately.

VR4U03 (3/8") - THREADED BODY (#1, #4 & #6)

Weight : 7.03 lbs (3.2 kg)

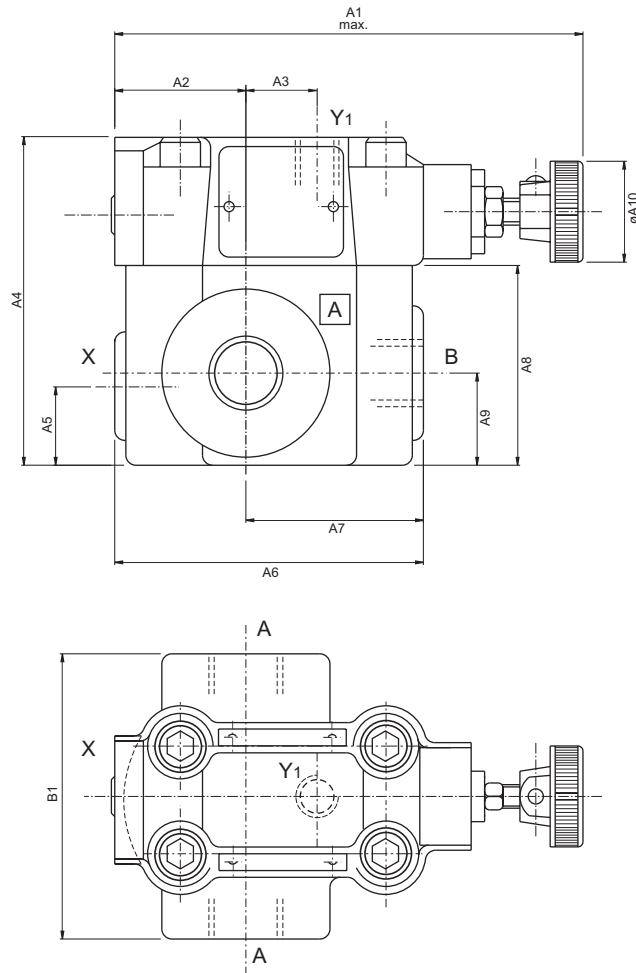

	Dimensions	
	in	mm
A1	5.55	141.0
A2	1.535	39.0
A3	0.807	20.5
A4	3.84	97.5
A5	0.92	23.3
A6	3.62	91.9
A7	2.08	52.8
A8	2.34	59.4
A9	1.08	27.4
A10	ø1.26	ø32.0

	Dimensions	
	in	mm
B1	3.34	84.8

Ports	Function	Port Sizes
A (2)	Pressure (inlet)	1/2" NPTF or G 1/2" or SAE - 8 (3/4" - 16 UNF)
B	Tank (outlet)	1/2" NPTF or G 1/2" or SAE - 8 (3/4" - 16 UNF)
X	Remote control or vent connection	1/4" NPTF or G 1/4" or SAE - 4 (7/16" - 20 UNF)
Y1	External drain	1/4" NPTF or G 1/4" or SAE - 4 (7/16" - 20 UNF)

CARTRIDGE WITH PILOT VALVE VR4U03 (#0, #E & #G)

Weight : 1.31 lbs (0.6 kg)

PC

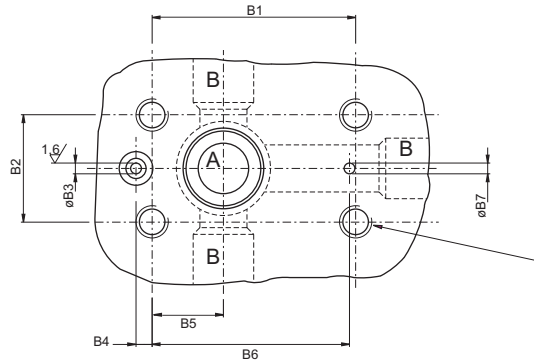
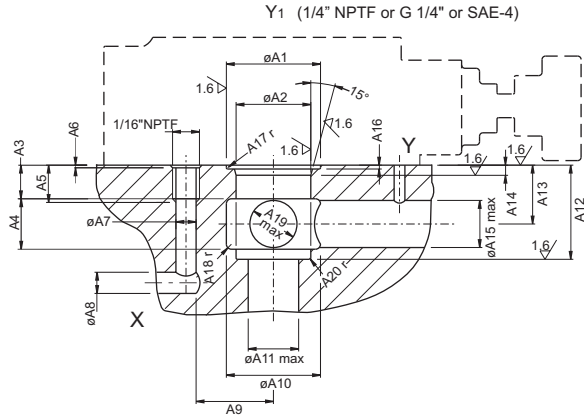

	Dimensions	
	in	mm
A1	ø1.102 ø1.107	ø28.0 ø28.1
A2	ø0.875 ø0.876	ø22.225 ø22.245
A3	0.4	10.0
A4	0.159	15.0
A5	0.437	11.1
A6	0.031	0.8
A7	ø0.236	ø6.0
A8	ø0.248	ø6.3
A9	0.905	23.0
A10	ø1.102	ø28.0
A11	ø0.59	ø15.0
A12	1.102 1.104	28.00 28.05
A13	0.69	17.5
A14	0.12	3.0
A15	ø0.55	ø14.0
A16	0.06/0.05	1.50/1.30
A17	0.016 r	0.4 r
A18	0.06 r	1.5 r
A19	ø0.58	ø14.0
A20	0.016 r	0.4 r

	Dimensions	
	in	mm
B1	2.383/2.367	60.52/60.12
B2	1.24/1.26	31.55/31.95
B3	ø0.126	ø3.2
B4	0.188	4.8
B5	2.311	58.7
B6	0.81	20.6
B7	ø0.126	ø3.2

Ports	Function
A	Pressure (Inlet)
B	Tank (Outlet)
X	External control connection
Y, Y ₁ ¹⁾	Drain

1) Port Y₁ is only available at drain line (code 2) external from the pilot head.

4 Mounting screws*	
Dimensions	Order No.
3/8" - 24 UNF x 1 ³ / ₄ lg. or M10 x 45mm, DIN 912 - 12.9	V359 - 15220 or V700 - 71602

* Mounting screws must be ordered separately