

FEATURES

Veljan VT* series Vane Pumps are high-performance fixed displacement pin vane design available in Single, Double, Triple and Drive Train configurations. These can be driven by fixed or variable speed prime movers.

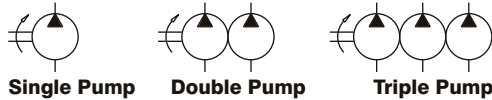

LONG SERVICE LIFE

Due to hydraulic pressure compensation and a rigid bearing arrangement, an outstanding operational life can be achieved by using Veljan Vane Pumps.

LARGE POWER RANGE

Veljan Vane Pumps offer a comprehensive range of Single, Double and Triple Vane Pumps in a large variety of flow capacities. Based on the individual maximum operating pressures, the corresponding power range varies. All pumps are light weight and compact in design, resulting in an exceptional power-to-weight ratio.

GREATER FLOW RANGE

Within the frame size of a pump, greater flow is achieved by increased displacement cam rings. "B" - 15 gpm, "C" - 31 gpm, "D" - 61gpm, "E" - 85 gpm.

LOW NOISE LEVEL

Reduced noise levels are well within the acceptable limits of the industry. Large size cartridge displacements optimize operation for the lowest noise level in the smallest envelope. Uni-directional cartridge pumps are more quiet in operation in comparison to bi-directional cartridge pumps.

MOUNTING FLEXIBILITY

Flexible and economical instillation - inlet and outlet ports can be arranged in different configurations, 4 positions for single pumps, 32 for double pumps and 128 for triple pumps.

MAXIMUM SPEED RATINGS

Speeds are influenced by specific gravity, viscosity and suction head. Maximum speed rating: 3600 rpm. Minimum speed rating: 400 rpm for mobile and 600 rpm for industrial applications. For specific speed, flow and pressure ratings of each series, please refer the general characteristics of Vane Pumps.

CARTRIDGE DESIGN

Veljan Vane Pumps feature pre-assembled cartridge kits which can be easily and quickly replaced without any major disassembly. The displacement of the pump within the same series can be changed by changing the camring or cartridge.

RELIABILITY

Excellent cold start capability and superior resistance to seizure make Veljan Vane Pumps highly reliable and efficient.

HIGHER PRESSURE

High pressure capability upto 4650 psi (320 bar).

HIGH EFFICIENCY

High volumetric efficiency (typically 94%) reduces heat generation, allows low speeds at full pressure and high mechanical efficiency (typically 94%) reduces energy consumption. Better efficiency under load increases productivity.

WIDER RANGE OF ACCEPTABLE VISCOSITIES

Viscosities from 2000 to 10 cst, permit colder starts and hotter running. The balanced design compensates for wear and temperature changes. Optimum operating viscosity of the oil should be between 16 cst (80 SUS) and 40 cst (180 SUS).

VERSATILE APPLICATIONS

Veljan Vane Pumps are used in all industrial and mobile applications of the industry and can be operated with mineral oils as well as fire resistant fluids.

FIRE RESISTANT FLUIDS

Phosphate esters, chlorinated hydrocarbons, water glycols and invert emulsions may be pumped at high pressures and with longer service life by these pumps.

ADVANTAGES

- ▶ Low ripple pressure reduces piping noise and increases life of other components in the circuit.
- ▶ High resistance to particle contamination because of double lip vane increases pump life.
- ▶ Large variety of options (cam displacement, shaft, port-positions) allows customized installation.
- ▶ Low speed, low pressure, high viscosity allows application in cold environments with minimum energy consumption and without risk of seizure.
- ▶ Camrings are dry lubricant coated and suitable for severe duty applications. This special coating helps in lubrication of the cam surface, especially during cold starts as also while in operation. Additionally this reduces wear which in turn extends life of the pump.
- ▶ Side feed holes reduce internal leakage, help balance internal pressures, improve lubrication and provide a cooling effect.
- ▶ Vane loading pins load the vane against the cam ring. Loading is in direct proportion to pump discharge pressure, which minimizes wear and prevents overshoot pressure and vane blow-off.
- ▶ The shaft option T (SAE J718c), allows direct drive (at 540 or 1000 RPM) on tractors.
- ▶ The double shaft seal (VT6* P) version and drain hole allow direct mounting onto gear boxes.

GENERAL CHARACTERISTICS

Series	Mounting Standard (SAE J744c ISO/3019-1)	Displacement (cm ³ /rev)	Speed		Max. Pressure		Weight (without connectors and bracket)		SAE 4-bolt J518-ISO/DIS 6162-1			Moment of Inertia																																																																																																																																																																																																																																																																																																																																																																																																																																				
			max	min	(psi)	(bar)	(lbs)	(kg)	suction	Pressure		lb.in ²	Kg m ² x10 ⁻⁴																																																																																																																																																																																																																																																																																																																																																																																																																																			
VTXB1	SAE - A	6 - 46	2500	600	3000	210	21.34	9.7	1" or 1¼"	3/4" or 5/8"		1.1	3																																																																																																																																																																																																																																																																																																																																																																																																																																			
VTXB2	SAE - B						23.98	10.9						VT6B	SAE - A	6 - 46	2500	600	3500	240	3.6	8.0	1¼"	¾"	1.1	3	VT6C / VT6CM	SAE - B	10.8 - 100.0	2800 ¹⁾	600 400	4000 ⁴⁾	275 ⁴⁾	34.0	15.5	1½"	1"	2.6	7.5	VT6CSH / VT6CSHM	SAE - B	10.8 - 100.0	2800 ¹⁾	600 400	4000 ⁴⁾	275 ⁴⁾	55.0	24.9	1½"	1" or ¾"	2.6	7.5	VT6CP	SAE - C	10.8 - 100.0	2800 ¹⁾	400	4000 ⁴⁾	275 ⁴⁾	39.7	18.0	2"	1¼"	2.7	7.8	VT6D / VT6DM	SAE - C	47.6 - 190.5	2500 ²⁾	600 400	3500 ⁴⁾	240 ⁴⁾	52.9	24.0	2"	1¼"	8.0	23.3	VT6E / VT6EM	SAE - C	132.3 - 269.8	2200 ³⁾	600 400	3500 ⁵⁾	240 ⁵⁾	95.5	43.3	3"	1½"	17.7	51.5	VT6GC	R.17-102	10.8 - 100.0	2800 ¹⁾	400	4000 ⁴⁾	275 ⁴⁾	39.7	18.0	1½"	1" SAE	3.1	9.1	VTXBB1	SAE - A	12 - 92	2500	600	3000	210	33	15.0	2"	P1		2.53	7.4	VTXBB2	SAE - B	¾" or 1/16"	¾" or 1/16"	VT6BB	SAE - B	¾"	¾"	VT6CB	SAE - B	17 - 140	2500	600	4000	275	53.9	24.5	2½"	1"	¼"	4.04	11.8	VT6CC / VT6CCM	SAE - B	P1 = 10.8 - 100.0 P2 = 10.8 - 100.0	2800	600 400	4000	275	57.4	26.0	2½" or 3"	1"	1" or ¾"	5.1	14.9	VT6CCSH / VT6CCSHM	SAE - B	P1 = 10.8 - 100.0 P2 = 10.8 - 100.0	2800	600 400	4000	275	75.0	34.0	2½" or 3"	1"	1" or ¾"	5.1	14.9	VT6GCC	R.17-102	P1 = 10.8 - 100.0 P2 = 10.8 - 100.0	2800	400	4000	275	60.0	27.2	2½" or 3"	1"	1" or ¾"	5.5	15.9	VT6DC / VT6DCM	SAE - C	P1 = 47.6 - 190.5 P2 = 10.8 - 100.0	2500	600 400	3500 4000	240 275	80.7	36.6	3"	1¼"	1" or ¾"	10.4	30.4	VT6DDS	SAE - C	P1 = 47.6 - 190.5 P2 = 47.6 - 190.5	2500	600	3500	240	123.4	56.0	4"	1¼"	1¼"	12.4	35.9	VT6EC / VT6ECM	SAE - C	P1 = 132.3 - 269.8 P2 = 10.8 - 100.0	2200	600 400	3500 4000	240 275	121.0	55.0	3½"	1½"	1"	25.0	73.4	VT6ED / VT6EDM	SAE - C	P1 = 132.3 - 269.8 P2 = 47.6 - 190.5	2200	600 400	3500 3500	240 240	145.5	66.0	4"	1½"	1¼"	25.0	73.4	VT6EE	ISO-3019-2 250 B4 HW	P1 = 132.3 - 269.8 P2 = 132.3 - 269.8	2200	600	3500	240	209.4	95.0	4"	1½"	1¼"	33.2	96.0	VT6EES	SAE - E													VT6CBB	SAE - B	P1 = 10.8 - 100.0 P2 = 6.5 - 39.7 P3 = 6.5 - 39.7	2500	600 400	4000 3500	275 240	70.4	32.0	2"	P1	P2	P3	--	--	VT6CCB	SAE - B	P1 = 10.8 - 100.0 P2 = 10.8 - 100.0 P3 = 6.5 - 39.7	2500	600 400	4000 3500	275 240	81.4	37.0	3"	1"	1"	3/4"	--	--	VT6DCB	SAE - C	P1 = 47.6 - 190.5 P2 = 10.8 - 100.0 P3 = 6.5 - 39.7	2500	600 400	4000 3500 3500	275 240 240	125.4	57.0	3"	1¼"	1"	3/4"	--	--	VT6DCC / VT6DCCM	SAE - C	P1 = 47.6 - 190.5 P2 = 10.8 - 100.0 P3 = 10.8 - 100.0	2500	600 400	3500 4000	240 275	134.5	61.0	4"	1¼"	1"	1" or ¾"	12.8	37.3	VT6DDCS	SAE - C	P1 = 47.6 - 190.5 P2 = 47.6 - 190.5 P3 = 10.8 - 100.0	2500	600	3500 4000	240 275	145.2	66.0	4"	1¼"	1¼"	1" or ¾"	14.6	42.6	VT6EDC	ISO/3019-2 250 B4 HW	P1 = 132.3 - 269.8	2200	600	3500	240									VT6EDCS / VT6EDCM	SAE E	P2 = 47.6 - 190.5 P3 = 10.8 - 100.0	400	3500 3500	240 275	220.4	100.0	4"	1½"	1¼"	1¾"	27.6	80.2	VT6CR / VT6CRM	SAE - B	10.8 - 100.0	2800	600 400	4000	275	37.6	17.1	1½"	1"		2.6	7.6	VT6DR / VT6DRM	SAE - C	47.6 - 190.5	2500	600 400	3500	240	63.9	29.0	2"	1¼"		8.16	23.4	VT6ER / VT6ERM	SAE - C	132.3 - 269.8	2200	600 400	3500	240	86.4	39.2	3"	1½"		17.7	51.6	VT6DCCR	SAE - C	P1 = 47.6 - 190.5 P2 = 10.8 - 100.0 P3 = 10.8 - 100.0	2500	600	3500 4000	240 275	136.7	62.0	4"	1¼"	1"	1" or ¾"	12.8	37.4	VT6EDCR	ISO/3019-2 250 B4 HW	P1 = 132.3 - 269.8 P2 = 47.6 - 190.5 P3 = 10.8 - 100.0	2200	600
VT6B	SAE - A	6 - 46	2500	600	3500	240	3.6	8.0	1¼"	¾"	1.1	3																																																																																																																																																																																																																																																																																																																																																																																																																																				
VT6C / VT6CM	SAE - B	10.8 - 100.0	2800 ¹⁾	600 400	4000 ⁴⁾	275 ⁴⁾	34.0	15.5	1½"	1"	2.6	7.5																																																																																																																																																																																																																																																																																																																																																																																																																																				
VT6CSH / VT6CSHM	SAE - B	10.8 - 100.0	2800 ¹⁾	600 400	4000 ⁴⁾	275 ⁴⁾	55.0	24.9	1½"	1" or ¾"	2.6	7.5																																																																																																																																																																																																																																																																																																																																																																																																																																				
VT6CP	SAE - C	10.8 - 100.0	2800 ¹⁾	400	4000 ⁴⁾	275 ⁴⁾	39.7	18.0	2"	1¼"	2.7	7.8																																																																																																																																																																																																																																																																																																																																																																																																																																				
VT6D / VT6DM	SAE - C	47.6 - 190.5	2500 ²⁾	600 400	3500 ⁴⁾	240 ⁴⁾	52.9	24.0	2"	1¼"	8.0	23.3																																																																																																																																																																																																																																																																																																																																																																																																																																				
VT6E / VT6EM	SAE - C	132.3 - 269.8	2200 ³⁾	600 400	3500 ⁵⁾	240 ⁵⁾	95.5	43.3	3"	1½"	17.7	51.5																																																																																																																																																																																																																																																																																																																																																																																																																																				
VT6GC	R.17-102	10.8 - 100.0	2800 ¹⁾	400	4000 ⁴⁾	275 ⁴⁾	39.7	18.0	1½"	1" SAE	3.1	9.1																																																																																																																																																																																																																																																																																																																																																																																																																																				
VTXBB1	SAE - A	12 - 92	2500	600	3000	210	33	15.0	2"	P1		2.53	7.4																																																																																																																																																																																																																																																																																																																																																																																																																																			
VTXBB2	SAE - B									¾" or 1/16"	¾" or 1/16"																																																																																																																																																																																																																																																																																																																																																																																																																																					
VT6BB	SAE - B									¾"	¾"																																																																																																																																																																																																																																																																																																																																																																																																																																					
VT6CB	SAE - B	17 - 140	2500	600	4000	275	53.9	24.5	2½"	1"	¼"	4.04	11.8																																																																																																																																																																																																																																																																																																																																																																																																																																			
VT6CC / VT6CCM	SAE - B	P1 = 10.8 - 100.0 P2 = 10.8 - 100.0	2800	600 400	4000	275	57.4	26.0	2½" or 3"	1"	1" or ¾"	5.1	14.9																																																																																																																																																																																																																																																																																																																																																																																																																																			
VT6CCSH / VT6CCSHM	SAE - B	P1 = 10.8 - 100.0 P2 = 10.8 - 100.0	2800	600 400	4000	275	75.0	34.0	2½" or 3"	1"	1" or ¾"	5.1	14.9																																																																																																																																																																																																																																																																																																																																																																																																																																			
VT6GCC	R.17-102	P1 = 10.8 - 100.0 P2 = 10.8 - 100.0	2800	400	4000	275	60.0	27.2	2½" or 3"	1"	1" or ¾"	5.5	15.9																																																																																																																																																																																																																																																																																																																																																																																																																																			
VT6DC / VT6DCM	SAE - C	P1 = 47.6 - 190.5 P2 = 10.8 - 100.0	2500	600 400	3500 4000	240 275	80.7	36.6	3"	1¼"	1" or ¾"	10.4	30.4																																																																																																																																																																																																																																																																																																																																																																																																																																			
VT6DDS	SAE - C	P1 = 47.6 - 190.5 P2 = 47.6 - 190.5	2500	600	3500	240	123.4	56.0	4"	1¼"	1¼"	12.4	35.9																																																																																																																																																																																																																																																																																																																																																																																																																																			
VT6EC / VT6ECM	SAE - C	P1 = 132.3 - 269.8 P2 = 10.8 - 100.0	2200	600 400	3500 4000	240 275	121.0	55.0	3½"	1½"	1"	25.0	73.4																																																																																																																																																																																																																																																																																																																																																																																																																																			
VT6ED / VT6EDM	SAE - C	P1 = 132.3 - 269.8 P2 = 47.6 - 190.5	2200	600 400	3500 3500	240 240	145.5	66.0	4"	1½"	1¼"	25.0	73.4																																																																																																																																																																																																																																																																																																																																																																																																																																			
VT6EE	ISO-3019-2 250 B4 HW	P1 = 132.3 - 269.8 P2 = 132.3 - 269.8	2200	600	3500	240	209.4	95.0	4"	1½"	1¼"	33.2	96.0																																																																																																																																																																																																																																																																																																																																																																																																																																			
VT6EES	SAE - E																																																																																																																																																																																																																																																																																																																																																																																																																																															
VT6CBB	SAE - B	P1 = 10.8 - 100.0 P2 = 6.5 - 39.7 P3 = 6.5 - 39.7	2500	600 400	4000 3500	275 240	70.4	32.0	2"	P1	P2	P3	--	--																																																																																																																																																																																																																																																																																																																																																																																																																																		
VT6CCB	SAE - B	P1 = 10.8 - 100.0 P2 = 10.8 - 100.0 P3 = 6.5 - 39.7	2500	600 400	4000 3500	275 240	81.4	37.0	3"	1"	1"	3/4"	--	--																																																																																																																																																																																																																																																																																																																																																																																																																																		
VT6DCB	SAE - C	P1 = 47.6 - 190.5 P2 = 10.8 - 100.0 P3 = 6.5 - 39.7	2500	600 400	4000 3500 3500	275 240 240	125.4	57.0	3"	1¼"	1"	3/4"	--	--																																																																																																																																																																																																																																																																																																																																																																																																																																		
VT6DCC / VT6DCCM	SAE - C	P1 = 47.6 - 190.5 P2 = 10.8 - 100.0 P3 = 10.8 - 100.0	2500	600 400	3500 4000	240 275	134.5	61.0	4"	1¼"	1"	1" or ¾"	12.8	37.3																																																																																																																																																																																																																																																																																																																																																																																																																																		
VT6DDCS	SAE - C	P1 = 47.6 - 190.5 P2 = 47.6 - 190.5 P3 = 10.8 - 100.0	2500	600	3500 4000	240 275	145.2	66.0	4"	1¼"	1¼"	1" or ¾"	14.6	42.6																																																																																																																																																																																																																																																																																																																																																																																																																																		
VT6EDC	ISO/3019-2 250 B4 HW	P1 = 132.3 - 269.8	2200	600	3500	240																																																																																																																																																																																																																																																																																																																																																																																																																																										
VT6EDCS / VT6EDCM	SAE E	P2 = 47.6 - 190.5 P3 = 10.8 - 100.0		400	3500 3500	240 275	220.4	100.0	4"	1½"	1¼"	1¾"	27.6	80.2																																																																																																																																																																																																																																																																																																																																																																																																																																		
VT6CR / VT6CRM	SAE - B	10.8 - 100.0	2800	600 400	4000	275	37.6	17.1	1½"	1"		2.6	7.6																																																																																																																																																																																																																																																																																																																																																																																																																																			
VT6DR / VT6DRM	SAE - C	47.6 - 190.5	2500	600 400	3500	240	63.9	29.0	2"	1¼"		8.16	23.4																																																																																																																																																																																																																																																																																																																																																																																																																																			
VT6ER / VT6ERM	SAE - C	132.3 - 269.8	2200	600 400	3500	240	86.4	39.2	3"	1½"		17.7	51.6																																																																																																																																																																																																																																																																																																																																																																																																																																			
VT6DCCR	SAE - C	P1 = 47.6 - 190.5 P2 = 10.8 - 100.0 P3 = 10.8 - 100.0	2500	600	3500 4000	240 275	136.7	62.0	4"	1¼"	1"	1" or ¾"	12.8	37.4																																																																																																																																																																																																																																																																																																																																																																																																																																		
VT6EDCR	ISO/3019-2 250 B4 HW	P1 = 132.3 - 269.8 P2 = 47.6 - 190.5 P3 = 10.8 - 100.0	2200	600	3500 4000	240 275	220.4	100.0	4"	1½"	1¼"	1" or ¾"	27.6	80.3																																																																																																																																																																																																																																																																																																																																																																																																																																		

1) Cartridges 025-028-031 = 2500 rpm max. 2) Cartridges 042-045-050-061 = 2200 rpm max. 3) Cartridges 085 = 2000 rpm max. 4) Cartridges 028-025-031-050(D) = 210 bar (3000 psi) max. int
 4) 061 (D) = 120 bar (1740 psi) max. int 061 = 80 bar (1160 psi) cont. 5) 085 (E) = 1232 psi (90 bar) max. int 085 (E) = 75 bar (1087 psi) cont.

* For operation with petroleum based fluids that contain additives which impart high anti-wear properties. (see page A0-8)

GENERAL CHARACTERISTICS

Series	Mounting Standard	Displacement (cm ³ /rev)	Speed		Max. Pressure		Weight (without connectors and bracket)		SAE 4-bolts J518-ISO/DIS 6162-1			Moment of Inertia		
			max	min	(psi)	(bar)	(lbs)	(kg)	suction	Pressure		Lb.in ²	Kg m ² x10 ⁻⁴	
VT7B	ISO 3019-2 100 A2 HW	5.7 - 50	3600 ¹⁾	600	4640 ⁴⁾	320 ⁴⁾	50.7	23.0	1½"	1" or ¾"		1.1	3.2	
VT7BS	SAE J744 SAE B													
VT7QC1	SAE B	10.8-100.0	3000 ²⁾	600	4350 ⁵⁾	300 ⁵⁾	50.7	23.0	1½"	1" or ¾"		2.6	7.5	
VT7QC2	SAE C													
VT7D	ISO 3019-2 125 A2 HW	43.9 - 158.0	3000 ²⁾	600	4350 ⁶⁾	300 ⁶⁾	57.3	26.1	2"	1¼"		5.7	19.5	
VT7DS	SAE J744 SAE C													
VT7E	ISO 3019-2 125 A2 HW	132.2 - 268.7	2200 ³⁾	600	3500 ⁷⁾	240 ⁷⁾	95.4	43.0	2"	1¼"		21.3	61.8	
VT7ES	SAE J744 SAE C													
VT7BB	ISO 3019-2 100 A2 HW	P1 = 5.7 - 50 P2 = 5.7 - 50	2200	600	4640	320	75.5	34.0	2½"	P1	P2	2.3	6.75	
VT7BBS	SAE J744 SAE B									1" or ¾"	¾"			
VT7QCC1	SAE B	P1 = 10.8-100.0 P2 = 10.8-100.0	3000	600	4350	300	75.5	34.0	2½"	1"	1" or ¾"	5.8	14.9	
VT7QCC2	SAE C													
VT7DB	ISO 3019-2 125 A2 HW	P1 = 43.9 - 158.0 P2 = 5.7 - 50	2500	600	3630	250	85.1	38.0	3"	1¼"	1" or ¾"	9.0	26.3	
VT7DBS	SAE J744 SAE C				4350	300								
VT7QDC	SAE J744 SAE C	P1 = 43.9-158.0 P2 = 10.8-100.0	2500	600	3630 4350	250 300	115.0	52.3	3"	1¼"	1" or ¾"	10.4	30.4	
VT7DD	ISO 3019-2 125 B4 HW	P1 = 43.9 - 158.0 P2 = 43.9 - 158.0	2500	600	3500	250	123.4	56.0	4"	1¼"	1¼"	12.4	35.9	
VT7DDS	SAE J744 SAE C													
VT7EB	ISO 3019-2 125 A2 HW	P1 = 132.2 - 268.7 P2 = 5.7 - 50.0	2200	600	3500	240	121.2	55.0	4"	1½"	1¼"	22.5	65.8	
VT7EBS	SAE J744 SAE C				4350	300								
VT7QEC	SAE J744 SAE C	P1 = 132.2-268.7 P2 = 10.8-100.0	2200	600	3500 4350	240 300	121.0	55.0	3½"	1½"	1"	25.0	73.4	
VT7ED	ISO 3019-2 125 A2 HW	P1 = 132.2 - 268.7 P2 = 43.9 - 158.0	2200	600	3500	240	145.5	66.0	4"	1½"	1¼"	27.2	78.9	
VT7EDS	SAE J744 SAE C				3630	250								
VT7EE	ISO 3019-2 250 B4 HW	P1 = 132.2 - 268.7 P2 = 132.2 - 268.7	2200	600	3500	240	209.4	95.2	4"	1½"	1¼"	33.2	90.0	
VT7EES	SAE J744 SAE E													
VT7DBB	SAE C	P1 = 43.9-158.0 P2 = 5.7-50.0 P3 = 5.7-50.0	2500	600	3500	240	134.5	61.0	4"	1¼"	1"	1" or ¾"	11.5	33.7
VT7QDCB	SAE C	P1 = 43.9-158.0 P2 = 10.8-100.0 P3 = 5.7-50.0			4000	275								
VT7QDCC	SAE C	P1 = 43.9-158.0 P2 = 10.8-100.0 P3 = 10.8-100.0			4000	275								
VT7DDB	ISO 3019-2 125 B4 HW	P1 = 43.9-158.0 P2 = 43.9-158.0 P3 = 5.7-50.0	2500	600	3630	250	145.5	66.0	4"	1¼"	1¼"	1" or ¾"	13.5	39.6
VT7DDBS	SAE J744 SAE C				4350	300								
VT7EDB	ISO 3019-2 250 B4 HW	P1 = 132.2-268.7 P2 = 43.9-158.0 P3 = 5.7-50.0	2200	600	3500	240	224.9	102.0	3"	1½"	1¼"	1" or ¾"	26.1	75.7
VT7EDBS	SAE J744 SAE E				3630	250								
VT7QEDC	ISO 3019-2 250 B4 HW	P1 = 132.2-268.7 P2 = 43.9-158.0	2200	600	3500	240	224.9	102.0	3"	1½"	1¼"	1" or ¾"	27.6	80.2
VT7QEDCS	SAE J744 SAE E				3630	250								

1) Cartridges B11-B12-B14-B15 = 3000 rpm max.

2) Cartridges 025-028-031 = 2500 rpm max.

2) Cartridges 045-050 = 2200 rpm max.

B35-B38 = 2800 rpm max. B42 = 2500 rpm max.

3) Cartridges 085 = 2000 rpm max.

4) Cartridges B11-B12-B14 = 300 bar (4350 psi) max.int

Cartridge B15 = 280 bar (4060 psi) max.int

5) Cartridges 022 = 275 bar (4000 psi) max.int

Cartridge 025 = 240 bar (3500 psi) max.int

Cartridge 028-031 = 210 bar (3000 psi) max.int

6) Cartridges B35-B38 = 280 bar (4060 psi) max.int

Cartridge B42 = 260 bar (3770 psi) max.int

Cartridge 045 = 240 bar (3500 psi) max.int

Cartridge 050 = 210 bar (3000 psi) max.int

7) Cartridges 085 = 90 bar (1300 psi) max.int

GENERAL CHARACTERISTICS

Series	Mounting Standard	Displacement (cm ³ /rev)	Speed		Max. Pressure		Weight (without connectors and bracket)		suction	SAE 4-bolts J518-ISO/DIS 6162-1			Moment of Inertia	
			max	min	(psi)	(bar)	(lbs)	(kg)		Pressure			Lb.In ²	Kg m ² x10 ⁻⁴
VT67BB	SAE B	12 - 100	2800	600	4350	300	57.2	26.0	2 1/2"	P1 1"	P2 1/4"	3.9	11.4	
VT67CB	SAE J744 SAE B	P1 = 10.8-100.0 P2 = 5.7-50.0	2800	600	4350	300	57.2	26.0	2 1/2"	1"	3/4"	3.9	11.4	
VT67DB	SAE J744 SAE C	P1 = 47.6-190.5 P2 = 5.7-50.0	2500	600	4350	300	80.5	36.6	3"	1 1/4"	3/4"	9.1	26.7	
VT67EB	SAE J744 SAE C	P1 = 132.2-269.8 P2 = 5.7-50.0	2200	600	4350	300	122.1	55.0	3 1/2"	1 1/2"	3/4"	23.8	69.8	
VT67EC	SAE J744 SAE C	P1 = 132.2-268.7 P2 = 10.8 - 100	2200	600	4000	275	121.2	55.0	3 1/2"	1 1/2"	1"	24.2	70.66	
VT67DBB	SAE J744 SAE C	P1 = 47.6-190.5 P2,P3 = 5.7-50.0	2500	600	4350	300	134.5	61.0	4"	P1	P2	P3	11.5	33.7
VT67DCB		1 1/4"								1"	3/4"			
VT67DCC	SAE J744 SAE C	P1 = 43.9-158 P2,P3 = 10.8-100.0	2200	600	4000	275	134.5	61.0	4"	1 1/4"	1"	1"or 3/4"	11.4	33.2
VT67DDCS	SAE J744 SAE C	P1,P2 = 43.9-158 P3 = 10.8-100.0	2200	600	4000	275	145.5	66.1	4"	1 1/4"	1 1/4"	1"or 3/4"	14.7	42.9
VT67EDB	ISO 3019-2 250 B4 HW	P1 = 132.2-269.8 P2 = 47.6-190.5 P3 = 5.7-50.0	2200	600	4350	300	220.4	100.0	4"	1 1/2"	1 1/4"	3/4"	26.1	76.6
VT67EDC	ISO 2019-2	P1 = 132.2-269.8 P2 = 43.9-158 P3 = 10.8-100.0	2200	600	4000	275	224.9	102.2	4"	1 1/2"	1 1/4"	1"or 3/4"	27.4	80.0

Calculations

To resolve	Performances required
Volumetric	
Displacement Vp [cm ³ /rev]	Requested flow Q [l/min]
Available flow Q [l/min]	Speed n [rev/min]
Input Power P [kW]	Pressure p [bar]

Routine
1. First calculation $V_p = \frac{1000 Q}{n}$
2. Choose Vp of pump immediatly greater (see tabulation)
3. Theoretical flow of this pump $Q_{th} = \frac{V \times n}{1000}$
4. Find Qs leakage function of pressure Qs = f(p) on curve at 10 or 24 cSt
5. available flow $Q_{in} = Q - Q_s$
Note: If this flow is too small or greater, other calculation must be done with other pump displacement.
6. Theoretical Input power $P_{in} = \frac{Q_{th} \times p}{600}$
7. Find Ps hydrodynamic power loss on curve.
8. Calculation of necessary Input Power $P_{in} = P + P_s$
9. Results
These calculations steps must be followed for each application

Example
Q = 60
n = 1500
p = 150
$V_p = \frac{1000 \times 60}{1500} = 40 \text{ cm}^3/\text{rev}$
VT6C 014 Vp = 46 cm ³ / rev
$Q_{th} = \frac{46 \times 1500}{1000} = 69 \text{ l/min}$
VT6C (AI-1-3): Qs = 5 l/min at 150 bar, 24 cSt
Q = 69 - 5 = 64 l/min
$P_{in} = \frac{69 \times 150}{600} = 17.3 \text{ kW}$
VT6C (AI-1-3): Ps at 1500 rev/min, 150 bar = 1.5 kW
P = 17.3 + 1.5 = 18.8 kW
$V = 46 \text{ cm}^3/\text{rev}$
Q = 64 l/min
P = 18.8 kW
} VT6C 014

INTERMITTENT PRESSURE RATING

VT6 units may be operated intermittently at pressures higher than the recommended continuous rating when the time weighted average of pressure is less than or equal to the continuous duty pressure rating.

This intermittent pressure rating calculation is only valid if other parameters; speed, fluid, viscosity and contamination level are respected.

For total cycle time more than 15 minutes please consult your VELJAN representative.

Example: VT6C-014

Duty cycle 4 min. at 275 bar
1 min. at 35 bar
5 min. at 160 bar

$$\frac{(4 \times 275) + (1 \times 35) + (5 \times 160)}{10} = 193.5 \text{ bar}$$

193.5 bar is lower than 240 bar allowed as continuous pressure for VT6C-014 with HF-O Fluid.

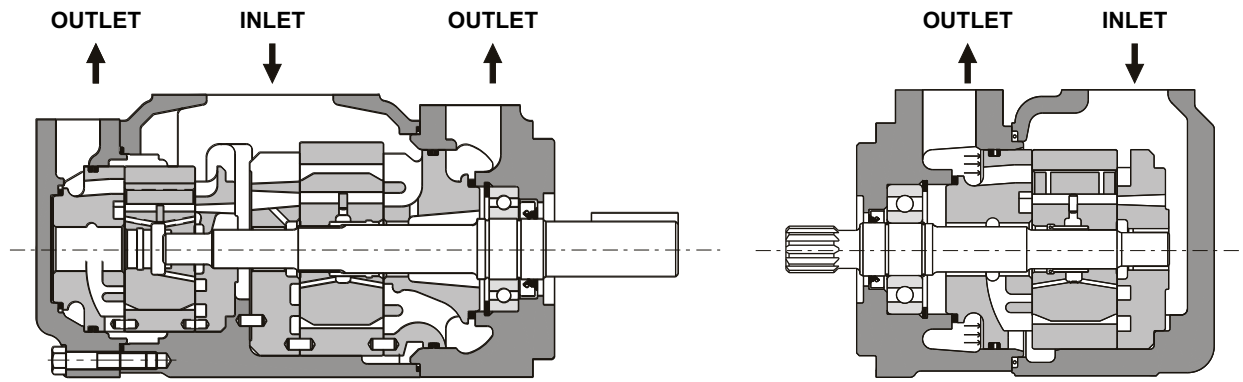

PUMP DESCRIPTION

Veljan Vane Pumps have a hydrostatically balanced cartridge which offers flexibility in pump sizes within a single series. A firm but light force against the vane is provided by the pin in order to follow the contour of the cam ring. All pumps can be supplied with flange or foot bracket mounting.

CHARACTERISTICS

Due to hydrostatic balance, the rotor carries no radial forces and, therefore, only transmits the torque generated by the operating pressure. Leakage is reduced to a minimum since the floating port plate is loaded by system pressure.

A wide viscosity range allows for operation under extreme temperature conditions. Longer service life, however, can be achieved by observing the recommended operating viscosity. The ambient temperature normally has no influence on the functional safety of the vane pumps.

PRINCIPLE OF OPERATION

The operating principle of a vane pump is illustrated in the figure above. A slotted rotor is driven within the cam ring by the shaft, coupled to a power source. As the rotor turns, vanes fitted in the radial slots of rotor follow the inner contour of the cam ring and provide two complete suction and pressure cycles during one revolution. Because of the eccentric design of the cam ring from the center line of the rotor, the rotor is loaded by the vanes only when they are on the major and minor arcs of the cam contour.

The displacement of the pump depends on the size of the cam ring and rotor and on the maximum distance the vane allowed to extend from the rotor surface to the cam ring surface.

The components of the cartridge are an elliptical cam ring, a slotted rotor, two port plates, vanes and vane pins fitted into the rotor slots. The inlet flow feeds through ports on both sides of the cartridge as well as through a large port through the cam ring at each suction ramp. This further permits greater displacement within the series, reduces wear and allows higher speed operation. As the outlet section is approached, the chamber volume decreases and the fluid is forced out into the system. System pressure is fed under the vanes, assuring their sealing contact against the camring during normal operation.

The pressure in the over-vane areas is equalized by the radial holes through the vanes. A firm but light force against the vane is provided by the pin subjected to the steady pin cavity pressure. This force assures smooth cam tracking by the vane. Thus in a light but steady contact, the vanes are held outward against the fluid film which separates them from the cam ring. Their radial position changes to follow the cam to adjust for fluid viscosity, contaminants and component wear.

The fluid film separates the rotor from the side port plates. The side port plates are clamped axially by an over balance of the internal pressure forces in the pumping cartridge. They accommodate dimensional changes due to temperature and pressure. Axial and radial running clearances, along with the lubricating oil film on the rotor and vanes, are optimized over the entire operating pressure range.

Rugged design and premium material selection, as well as the minimum number of rotating parts, contribute to the low noise levels and long efficient service life of Veljan Vane Pumps.

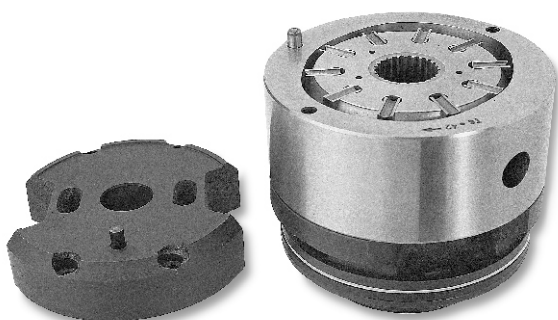

Pump cartridge

DOUBLE AND TRIPLE PUMPS

The VT* series Double Vane Pump is two hydraulic pumps and VT* series Triple Vane Pump is three hydraulic pumps in a single pump housing. Each is driven by the common shaft and is fed from the common inlet port. Each discharges from its separate outlet port and operates only at the pressure imposed on it. All pumps drain internally to the inlet port and hence no external drain is required.

MOBILE VERSION VANE PUMPS

The working principle of operation of these pumps is same as industrial version except for a few modifications in the internal design of components. The cartridges offered in this version are bi-directional and indicated by "B" description in cartridge model number. Pump rotation is easy to change by changing position of cam ring on port plate dowel pin hole in the bi-directional design pumps.

The design features that differ from the normal industrial version Vane Pump are illustrated in the figures below:

Vane is urged outward at suction ramp by pin force and centrifugal force.

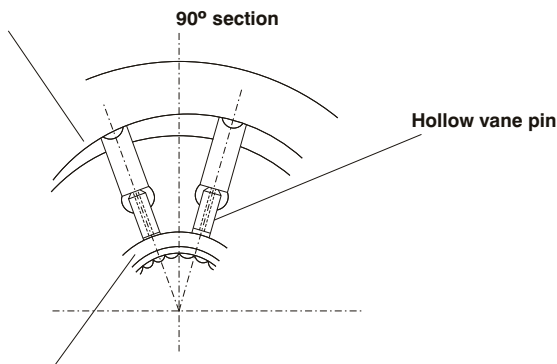

Pin cavity is at a steady pressure slightly higher than at discharge port.

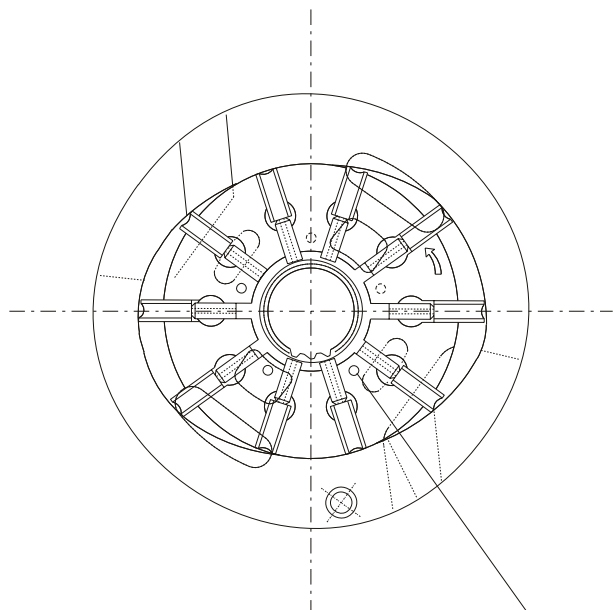

Lubrication holes for lubricating the port plates surfaces

GENERAL APPLICATION INSTRUCTIONS

1. Check speed range, pressure, temperature, fluid quality, viscosity and pump rotation.
2. Check Inlet conditions of the pump, if it can accept application requirement.
3. **Type of shaft:** If it would support operating torque.
4. Coupling must be chosen to minimize pump shaft load (weight, misalignment)
5. **Filtration:** Must be adequate for lowest contamination level.
6. **Environment of pump:** To avoid noise reflection, pollution and shocks.

PRIMING AT STARING

When the pump is set into operation for the first time, it must be primed at the lowest possible speed and pressure. When pressure relief valve is used at the outlet, it should be backed off to minimize return pressure. When possible an air bleed off should be provided in the circuit to facilitate purging of system air.

Never operate pump shaft at top speed and pressure without checking the pump priming is completed.

Absolute Inlet Pressure Pa min (bar)																						
Speed	Pump-cam VT6B								Pump-cam VT7B													
	rev/min	B02	B03	B04	B06	B08	B09	B12	B02	B03	B04	B05	B06	B07	B08	B09	B10	B11	B12	B14	B15	
1200	0.80	0.80	0.80	0.80	0.80	0.80	0.80		0.80	0.80	0.80	0.80	0.80	0.80	0.80	0.80	0.80	0.80	0.80	0.80		
1500	0.80	0.80	0.80	0.80	0.80	0.80	0.80		0.80	0.80	0.80	0.80	0.80	0.80	0.80	0.80	0.80	0.80	0.80	0.80		
1800	0.80	0.80	0.80	0.80	0.80	0.80	0.80		0.80	0.80	0.80	0.80	0.80	0.80	0.80	0.80	0.80	0.80	0.80	0.80		
2100	0.80	0.80	0.80	0.80	0.80	0.80	0.80		0.80	0.80	0.80	0.80	0.80	0.80	0.80	0.80	0.80	0.80	0.80	0.80		
2200	0.80	0.80	0.80	0.80	0.80	0.80	0.80		0.80	0.80	0.80	0.80	0.80	0.80	0.80	0.80	0.80	0.80	0.80	0.80		
2300	0.80	0.80	0.80	0.80	0.80	0.85	0.85		0.80	0.80	0.80	0.80	0.80	0.80	0.80	0.80	0.80	0.80	0.80	0.80		
2500	0.90	0.90	0.90	0.90	0.90	0.90	0.92		0.80	0.80	0.80	0.80	0.80	0.80	0.80	0.80	0.80	0.80	0.85	0.85		
2800									0.80	0.80	0.80	0.80	0.80	0.80	0.80	0.80	0.80	0.80	0.99	0.99		
3000									0.80	0.80	0.80	0.80	0.82	0.82	0.85	0.85	0.90	0.90	0.90	1.13	1.13	
3600									0.80	0.80	0.80	0.80	0.98	0.98	1.04	1.04	1.15					

Speed	Pump-cam VT6C												Pump-cam VT6D										Pump-cam VT6E							
	rev/min	003/008	010	012	014	015	017	022	025	028	031	014/020	024	028	031	035	038	042	045	050	061	042	045	050	052	057	062	066	072	085
1200	0.80	0.80	0.80	0.80	0.80	0.80	0.80	0.80	0.80	0.80		0.80	0.80	0.80	0.80	0.80	0.80	0.80	0.80	0.80		0.80	0.80	0.80	0.80	0.80	0.80	0.80	0.80	0.80
1500	0.80	0.80	0.80	0.80	0.80	0.80	0.80	0.80	0.80	0.80		0.80	0.80	0.80	0.80	0.80	0.80	0.80	0.80	0.80		0.80	0.80	0.80	0.80	0.80	0.80	0.85	0.80	0.85
1800	0.80	0.80	0.80	0.80	0.80	0.80	0.80	0.80	0.80	0.80		0.80	0.80	0.80	0.80	0.80	0.80	0.80	0.85	0.80		0.85	0.80	0.80	0.80	0.85	0.85	0.95	0.85	0.95
2100	0.80	0.80	0.80	0.80	0.80	0.80	0.85	0.90	0.90	0.90		0.80	0.82	0.85	0.90	0.92	0.95	0.95	0.98	0.98		0.98	0.90	0.90	0.90	0.95	0.95	1.00	0.95	
2200	0.80	0.80	0.80	0.80	0.80	0.85	0.90	0.95	0.98	0.98		0.88	0.88	0.92	0.95	0.98	1.00	1.02	1.05	1.05		1.02	1.00	1.05	1.00	1.00	1.00	1.09	1.00	
2300	0.80	0.85	0.85	0.90	0.90	0.90	0.95	0.98	1.00	1.00		0.95	0.95	1.00	1.00	1.02	1.05	1.08												
2500	0.90	0.90	0.92	0.95	0.95	0.95	0.98	1.05	1.08	1.11		1.00	1.10	1.18	1.23	1.29	1.29													
2800	1.00	1.00	1.00	1.00	1.00	1.03	1.05																							

Speed	Pump-cam VT7D												Pump-cam VT7E									
	rev/min	B14	B17	B20	B24	B28	B31	B35	B38	B42	045	050	042	045	050	052	057	062	066	072	085	
1200	0.80	0.80	0.80	0.80	0.80	0.80	0.80	0.80	0.80	0.80	0.80		0.80	0.80	0.80	0.80	0.80	0.80	0.85	0.85	0.90	
1500	0.80	0.80	0.80	0.80	0.80	0.80	0.80	0.80	0.80	0.80	0.80		0.80	0.80	0.80	0.80	0.80	0.80	0.85	0.85	0.90	
1800	0.80	0.80	0.80	0.80	0.80	0.80	0.80	0.80	0.80	0.85	0.85		0.85	0.80	0.80	0.80	0.85	0.85	0.95	0.85	1.00	
2100	0.80	0.80	0.80	0.80	0.80	0.80	0.80	0.80	0.80	0.98	0.98		0.90	0.90	0.90	0.90	0.95	0.95	1.00	1.00		
2200	0.80	0.80	0.80	0.80	0.80	0.80	0.80	0.80	0.80	1.05	1.08		1.00	1.00	1.00	1.00	1.00	1.00	1.09	1.05		
2300	0.80	0.80	0.80	0.80	0.80	0.80	0.80	0.80	0.80													
2500	0.80	0.80	0.80	0.80	0.80	0.80	0.85	0.86	0.90													
2800	0.80	0.82	0.83	0.86	0.88	0.90	0.97	1.00														
3000	0.80	0.86	0.88	0.95	1.00	1.05																

Inlet pressure is measured at inlet flange with petroleum base fluids at viscosity between 10 to 65 cSt.

The difference between inlet pressure at the pump flange and atmospheric pressure must not exceed 0.2 bar to prevent aeration.

Multiply Absolute Pressure by 1.25 for HF-3, HF-4 fluids.
by 1.35 for HF-5 fluids.

Use highest cartridge absolute pressure for double pump.

INTERNAL LEAKAGE

While these pumps are designed for high volumetric efficiency, the internal leakage mainly depends on the load, viscosity of oil and the operating temperature. The typical internal leakage curves are shown in respective pump section.

INSTALLATION INSTRUCTIONS

1. Check direction of rotation as per the arrow mark shown on the pump body.
2. Ensure coupling connection to the driven shaft through proper coupling to minimize pump shaft load.
3. Check the filter suitability for lowest contamination level.
4. Check inlet conditions of the pump. Intake condition for all pumps should be suitable for easy flow of oil. As far as possible, try to avoid bends and use large size pipes as recommended.
5. Check the shaft suitability for supporting operating torque.
6. Suction line pressure - it is recommended to maintain a pressure at the inlet port between 0 to 1.5 bar.

Flow rate and power consumption are proportional to the rotational speed.

MOTOR-PUMP COUPLING

Vane Pumps can be installed in any position but axial and radial loads are not allowed on the shaft. Appropriate couplings and bell housing to be used as required.

LIMIT OF SHAFT TORQUE

The values of torque needed to operate the pumps are shown for each type of pump in the installation dimensions.

RECOMMENDED FLUIDS

Petroleum based antiwear R & O fluids.

These are the recommended fluids for VT* series pumps. Maximum catalog ratings and performance data are based on operation with these fluids. These fluids are covered by Denison HF-0 and HF-2 specification.

ACCEPTABLE ALTERNATE FLUIDS

The use of fluids other than petroleum based antiwear R & O fluids, reduces the maximum ratings of the pumps to be reduced. In some cases the minimum replenishment pressures must be increased. Consult specific sections for more details. These fluids are HF-1= Non antiwear petroleum base, HF-5= Synthetic fluids, HF-3= Water in oil emulsions, HF-4= Water glycols, Esters & Rapeseed base Biodegradable fluids.

VISCOSITY

Max (cold start, low speed & pressure)	
Industrial Pump	860 mm ² /s (cSt), 3900 SUS
Mobile Pump	2000 mm ² /s (cSt), 9240 SUS
Max (full speed & pressure)	108 mm ² /s (cSt), 500 SUS
Optimum (max life)	30 mm ² /s (cSt), 140 SUS
Min (full speed & pressure for HF-1, HF-3, HF-4 & 5 fluids)	18 mm ² /s (cSt), 90 SUS
Min (full speed & pressure for HF-0, HF-2 fluids)	10 mm ² /s (cSt), 60 SUS

VISCOSITY INDEX

90° min. Higher values extend range of operating temperatures.

Maximum Fluid Temperature (θ)°K

HF-0, HF-1, HF-2	= 373 (+ 100°C, + 212°F)
HF-3, HF-4	= 323 (+ 50°C, + 122°F)
HF-5	= 343 (+ 70°C, + 158°F)
Biodegradable fluids (esters & rapeseed base)	= 338 (+ 65°C, + 149°F)
Minimum fluid Temperature (θ)°K	
HF-0, HF-1, HF-2, HF-5	= 255 (- 18°C, - 0.4°F)
HF-3, HF-4	= 283 (+ 10°C, + 50.0°F)
Biodegradable fluids (esters & rapeseed base)	= 253 (- 20.2°C, - 4.4°F)

FLUID CLEANLINESS

The fluid must be cleaned before and during operation to maintain contamination level of NAS 1638 class 8 (or ISO18/14) or better. Filters with 25 micron (or better, β10 ≥ 100) nominal rating may be adequate but do not guarantee the required cleanliness levels. Suction strainers must be of adequate size to provide minimum inlet pressure specified. 100 mesh (149 micron) is the finest mesh recommended. Use oversize strainers or omit them altogether in applications which require cold start or use fire resistant fluids.

OPERATING TEMPERATURES AND VISCOSITIES

Operating temperatures are a function of fluid viscosities, fluid type, and the pump. Fluid viscosity should be selected to provide optimum viscosity at normal operating temperatures. For cold starts, the pumps should be operated at low speed and pressure until fluid warms up to an acceptable viscosity for full power operation.

WATER CONTAMINATION IN THE FLUID

Maximum acceptable content of water.

- ▶ 0.10 % for mineral base fluids.
- ▶ 0.05 % for synthetic fluids, crankcase oils, biodegradable fluids.

If amount of water is higher, then it should be drained off the circuit.

SHAFTS, COUPLINGS AND FEMALE SPLINES

- ▶ The mating female spline should be free to float and find its own center. If both members are rigidly supported, they must be aligned within 0.15 mm(0,006") TIR or less to reduce fretting. The angular alignment of two splines axes must be less than ± 0.05 mm per 25.4 mm radius.(± 0.002 " per 1" radius.).
- ▶ The coupling spline must be lubricated with a lithium molydi- sulfide grease or a similar lubricant.
- ▶ The coupling must be hardened to a hardness between 27 and 45 RC.
- ▶ The female spline must be made to conform to the class 1 fit as described in SAE-J498b (1971). This is described as a Flat Root Side Fit.

KEYED SHAFTS

Veljan supplies the VT* series pin vane pumps with option of keyed & splined shafts. Keyed shafts are supplied with high strength heat-treated keys. Therefore, when installing or replacing these pumps, the heat-treated keys must be used in order to ensure maximum life in the application. If the key is replaced, it must be heat-treated between 27 and 34 RC hardness. The corners of the keys must be chamfered from 0.76mm to 1.02mm (0.03" to 0.04") at 45° to clear radii in the key way.

Alignment of keyed shafts must be within tolerances given for splined shafts.

SHAFT LOADS

These products are designed primarily for coaxial drives which do not impose axial or side loading on the shaft, which may include vibration and shock during operation of the machine or external load on the drive shaft. Please contact Veljan representative for further details.

DRIVE TRAIN VANE PUMP VT*R

ADAPTORS
SAE A
SAE B
SAE C
mounting

Coupling comes in a variety of options to meet SAE standards.

SAE A
SAE B
SAE BB
SAE C

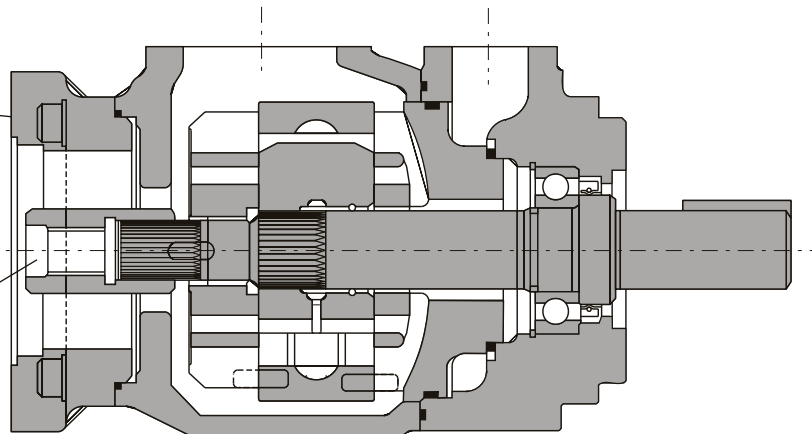

CONCEPT

Veljan VT6*R series Drive Train Vane Pumps have a rear pad for directly mounting and driving an additional pump. Many different multi-pump arrangements are thus possible. These Vane Pumps incorporate a mounting pad and internal variable Gear / Vane / Piston Pump.

REAR DRIVE MOUNTING

- ▶ This unit accepts a hydraulic pump with a mounting configuration conforming to SAE J 744c and ISO 3019-1
- ▶ Single Vane Pumps: SAE A/B/C adaptors SAE A/B/BB/C coupling.
- ▶ Triple Vane Pumps: SAE A adaptor and coupling.

APPLICATION ADVANTAGES

- ▶ Reduces installation costs by providing a single drive source for multiple pumps.
- ▶ Eliminates external drive couplings and reduces requirements of double shaft extensions or multiple electric motors.
- ▶ These configurations also provide valuable circuit and application flexibility.
- ▶ Wide range of flow levels on a common electric motor.
- ▶ Flexible, serviceable, quiet and energy-efficient hydraulic systems.
- ▶ Available for both mobile and industrial applications.

FORMULA FOR	LETTER FORMULA	WORD FORMULA
FLUID PRESSURE, P (lbs/in ²)	PRESSURE = $\frac{\text{FORCE (lbs)}}{\text{AREA (in}^2\text{)}}$	$P = \frac{F}{A}$
CYLINDER AREA (in ²)	AREA = $\frac{\pi}{4} \times \text{diameter}^2(\text{in})$ or $\times \text{radius}^2(\text{in})$	$A = \frac{\pi D^2}{4}$ or $.785 D^2$ or πr^2
FORCE (PUSH OR PULL)	FORCE = PRESSURE (psi) x AREA (in ²)	F = PA
PUMP INPUT POWER, HP	HORSEPOWER = $\frac{\text{FLOW (gpm)} \times \text{PRESSURE (psi)}}{1714 \times \text{OVERALL EFFICIENCY}}$	$HP = \frac{Q \cdot P}{1714 \cdot \eta_o}$
VELOCITY or SPEED (ft./sec)	VELOCITY = $\frac{231 \times \text{FLOW RATE gpm}}{12 \times 60 \times \text{AREA (sq. inches)}}$	$V = \frac{231 Q}{720 A}$
VOLUME, V (gpm)	VOLUME = $\frac{\pi \times \text{RADIUS}^2 (\text{inches}) \times \text{STROKE (inches)}}{231}$	$V = \frac{\pi r^2 L}{720 A}$
FLOW, Q (gpm)	FLOW = $\frac{\text{Displacement (in}^3\text{/rev)} \times \text{speed (rpm)}}{231}$	$Q = \frac{d \cdot n}{231}$
VOLUMETRIC EFFICIENCY η_v (PUMP)	Vol. Eff = $\frac{\text{OUTPUT (gpm)}}{\text{THEORITICAL (gpm)}} \times 100$	
OVERALL EFFICIENCY, η_o	Ove. Eff = $\frac{\text{OUTPUT HP}}{\text{INPUT HP}} \times 100$	
MOTOR TORQUE, T (inlbs/psi)	TORQUE = $\frac{\text{PRESSURE (psi)} \times \text{MOTOR DISPLACEMENT (in}^3\text{/rev)}}{2 \pi}$	$T = \frac{P d}{2 \pi}$
MOTOR TORQUE	= $\frac{63025 \times \text{HORSE POWER}}{\text{Speed (rpm)}}$	$T = \frac{63025 \text{ HP}}{n}$
	= $\frac{36.77 \times \text{FLOW RATE (gpm)} \times \text{PRESSURE (psi)}}{\text{Speed (rpm)}}$	$T = \frac{36.77 Q P}{n}$
MOTOR TORQUE, T/100 psi	TORQUE/ 100 psi = $\frac{\text{MOTOR DISPLACEMENT (in}^3\text{/rev.)}}{0.0628}$	$T/100 \text{ psi} = \frac{d}{0.0628}$
MOTOR SPEED, n (rpm)	SPEED = $\frac{231 \times \text{FLOW RATE (gpm)}}{\text{MOTOR DISPLACEMENT (in}^3\text{/rev.)}}$	$n = \frac{231 Q}{d}$
MOTOR POWER, HP	HORSE POWER = $\frac{\text{TORQUE OUTPUT (inch pounds)} \times \text{Speed (rpm)}}{63025}$	$HP = \frac{T \cdot n}{63025}$
VOLUMETRIC EFFICIENCY, η_v (MOTOR)	Vol. Eff = $\frac{\text{THEORITICAL gpm}}{\text{INPUT (gpm)}} \times 100$	

Pipe volume varies as the square of the diameter; volume in gallons = $0.0034 D L^2$

where D = inside diameter of pipe in inches L = length in inches

$$\text{Velocity in feet per second} = \frac{0.408 \times \text{flow (gpm)}}{D}$$

where D = inside diameter of pipe in inches

Specific gravity of oil is approximately 0.85

Thermal expansion of oil is about 1 cu. in. per 1 gallon per 10° F rise in temperature

Conversion Factors :

1 HP = 0.746 kW hr 1 bar = 14.5053 psi 1 kg = 2.2045 lbs

1 US gallon = 231 cubic inches. 3.8 lpm 1 kg = 9.8066 N

**VANE PUMP CHARACTERISTICS
OPERATING SPEED**

Maximum rated speeds are based on inlet pressure of 14.7 psi with the pump at sea level and operating with SAE 10 W oil at 40° to 80° C.

Minimum recommended speed is generally 600 rpm for industrial series pumps and 400 rpm for mobile series pumps. Depending upon pump size, operating pressure and environmental conditions, these speeds can be reduced or increased.

SUCTION PRESSURE

Recommended Suction (Inlet) Pressure is 0 to 5 psi gauge and should not exceed 20 psi (1.4 bar).

PRESSURE RATING

Pumps should not be operated at rated pressures at idle speeds for longer periods. In case they are run, overheating and damage can occur.

POSITIVE PRESSURE

A pressurised reservoir system does not ensure positive (supercharge) pressure at the pump inlet. Until the system has warmed up and the positive pressure actually exists at the pump inlet, pump should not be operated at high speeds.

SHAFT ALIGNMENT

Concentricity and angular alignment of shafts are very important to pump life. Misalignment can cause heavy loads on bearings leading to premature failure. Flexible coupling alignment is preferred and the usage of these couplings should be as per the recommendations of manufacturers.

Ensure that shaft is not subjected to excess torque and side loads.

Universal Joints

For double Universal Joint Couplings, the shafts must be parallel and the yokes must be in line. Maximum allowable offset should be minimised as per the application conditions. There should not be any looseness in the close fit of the pump shaft to the universal diametrical fit.

MOUNTING ACCESSORIES

Pumps with splined shafts are recommended for applications where the pump is coupled directly into a gear box. This is preferred more in mobile applications.

The possibility of interference between the shaft and the mating splines of the transmission, due to tolerance stack-up, can exist. This is reduced with the usage of tooth spline fits. A side tooth fit and short length of engagement permits more flexibility and less tendency for side loading than does a major diameter fit spline or long length spline fit.

**VANE MOTOR CHARACTERISTICS
OPERATING SPEED**

The Maximum speed (rpm) for the maximum pressure ratings of Veljan Vane Motors are as under :

	CONTINUOUS	INTERMITTENT
VM3B/VM3B1	3000	3600
VM4C/VM4C1 VM4SC/VM4SC1	2500	3600
VM4D/VM4D1 VM4SD/VM4SD1	2500	3000
VM4E/VM4E1 VM4SE/VM4SE1	2500	3000

Motors not to be operated for more than six seconds per minute of operation at the intermittent speeds.

Minimum operating speeds can be as low as 200 to 400 rpm. But as these motors are rated for high speed performance these are not very efficient at very low speeds. Depending upon torque requirements and characteristics of the driven load, lower operating speeds are recommended. Please contact Veljan representative for specific application of low speeds.

STALL TORQUE

Motor stall torque range between 60% and 100% of 1200 rpm running torque for a given pressure differential across the motor. This is dependent on the specific angular position of the shaft at stall and the volume of supply of oil to the motor.

HYDRAULIC BRAKING

Motors can be used as retarders but not as hydraulic brakes. Systems requiring positive holding capabilities must be provided with externally operated mechanical holding devices.

While using motor as a retarder, the maximum pressure is dependent on the speed. At speeds below 1200 rpm, maximum obtainable pressure is proportionally reduced relative to speed. Adequate pressure must be provided at the inlet port of the motor when it is used as a retarder, other wise cavitation can occur.

Consult Veljan representative for additional information for using motors as retarders.

DRIVE DATA

Veljan Vane units are designed for use on direct coaxial drives using spline connections or flexible coupling.

MOUNTING REQUIREMENTS

Dimensional control requirements of the mounting pad to which the pump or motor is fixed are as under :

The clearance between the male and female pilot diameters must be +0.0005 to 0.0020 in (+0.01 to 0.05 mm). Concentricity of the female pilot diameter relative to the effective axis of the female drive must be within 0.004 in (0.1mm).

Mounting face to which the pump or motor is assembled must be square to the axis of the female drive within 0.0015 inch per inch (0.0381 mm per mm).

Dimensions of keyed shaft receivers must be between +0.0001 and 0.0010 in (+0.003 to 0.03 mm) of the maximum shaft diameter shown in the installation dimensions of the Vane units.

CIRCUITARY REQUIREMENTS

In the event of acceleration or deceleration of the drive or driven unit, overrunning loads or system bleed off, the circuitary design and control valves must ensure a continuous supply of oil to the pump or motor. The oil supply should be adequate to prevent cavitation, but not excess which results in variation of speeds beyond the rated maximum speed.

Relief Valves must prevent surges from exceeding rated pressure ratings. Never assume that the relief valve setting is the maximum pressure a pump experiences. Shock conditions may exist which can exceed circuit and pump limitations.

PIPE LINES

Hydraulic Pipe Lines should be as short as possible with large inside diameters. For long lines, it is preferred to adapt larger capacity lines than the specified unit ports. Suction, outlet and drain lines should not be smaller than the nominal port size shown in installation drawings. usage of "Y" shaped inlet should be avoided to feed two separate pumps because one may be starved and cavitate.

The number of bends and fittings in the lines should be minimised as far as possible. In particular, bends to be avoided to the possible extent in the inlet line. High pressure lines and fittings are restrictive to flow and may result in excessive pressure drop through the system. They should be only used as required in the pressure line.

HOSES

Due to the movement of steering components during operation, the hydraulic lines should consist mainly of flexible hoses. Long lines may be partly flexible hose and partly rigid piping where flexibility is not required. While installing a hose, allow enough slack to avoid kinking A taut hose will not allow movement with pressure surges. Slack in the line compensates for surges, relieving strain.

During installation or while in operation, the hose should not be twisted. Twisting will weaken the hose and loosen the connections.

For power steering pumps using a remote reservoir, connecting hoses should not exceed three feet in length. It is preferred to design the reservoir such that there is always a static head on the pump inlet port.

As far as possible, we should minimise long loops in a line by using extra fittings. Hoses should be clamped to prevent rubbing and entanglement with moving parts. The Hoses should be run through shielded metallic guards when they are subject to chafing.

FLUID CONSIDERATIONS

Normal pump operating at rated conditions is based on the use of SAE W oil in the 40° to 80° C range.

PERMISSIBLE VISCOSITY

When operating with SAE 10W oil in the 860 to 4 cSt (4000 to 180 SUS) range (oil temperature - 12° to 35°C) the speed and pressure ratings of the pump should be limited to 50% or less of the respective rated value until the system has warmed up. Precaution must be taken while starting the system when fluid viscosity is greater than 860 cSt (4000 SUS). In such condition, we must warm up the hydraulic oil. Remote components such as motors, cylinders should be actuated during the process of warm-up.

Fluid viscosities must not be less than 60 SUS, and temperatures should not exceed 90° C because the life expectancy of rotating components and seals will decrease.

Care should be taken to use the appropriate oil of prescribed viscosity depending upon the climatic conditions.

Consult Veljan representative for reduction in pressure ratings, and modifications for usage of other fluids as per the operating conditions.

FLUID CLEANLINESS

Use of proper fluid is essential for long life of hydraulic components and systems. Hydraulic fluid must have the correct balance of cleanliness, antiwear additives, proper viscosity and inclusion of air.

Recommended cleanliness levels for petroleum oils under normal conditions are based on the highest fluid pressure levels in the system as indicated below.

Product	System Pressure Level		
	1000 psi (70 bar)	2000 psi (140 bar)	3000 psi (210 bar)
Vane Pumps * Vane Motors * (* fixed displacement)	20/18/15	19/17/14	18/16/13

Fluids other than petroleum, severe service cycles or temperature extremes are cause for adjustment of these cleanliness codes.

AERATION

Circuit design and reservoir must prevent aeration of the oil. Proper care must be taken to ensure that joint, seals and gaskets will not leak or deteriorate. This is most important in low pressure and suction lines. Connections should be tightened properly to prevent air from entering the system.

It is recommended to use sight glasses in the reservoir in order to determine whether significant amounts of air is present in the fluid or not. Fluid bubbles on the surface of the reservoir may indicate the presence of excessive aeration.

Note: Do not operate if the fluid is milky and not clear.

RESERVOIRS

OIL LEVEL

Oil level of the reservoir should be as high as possible above the suction line opening. All return lines should discharge near the tank bottom, always below the oil level, and far away from the pump inlet.

Reservoirs should incorporate means (dip stick, sight gauge etc.) for easy checking of the oil level. In the absence of these devices, the oil level cannot be checked and in case of a leak, the pump can be starved and damaged due to loss of lubrication property.

It is preferable for location of reservoirs above the pumps. This causes flooded suction for the pump and reduces the possibility of pump cavitation.

SUCTION AND RETURN LINES

Pump inlet and tank return lines should be attached to the reservoir by flanges or welded heavy duty coupling. If the inlet (suction) line is connected to the bottom of the reservoir, the coupling should extend above the bottom inside the tank.

This prevents residual dirt entering the suction line when the tank is cleaned. Proper seals should be used on all the suction line connections so that they will not leak nor deteriorate.

BAFFLE PLATE

A baffle plate in the reservoir is recommended to separate the suction and return lines. The plate helps return oil to circulate around the outer wall of the reservoir for cooling before it reenters the pump. It also helps entrained air to separate from the oil. Cascade effects are minimised by providing baffle plate opening.

MAGNETS

Magnets in a reservoir should be able to pick up ferrous particles not retained by filters or strainers. Magnets should be assembled to the support bars located between suction and return lines, and should be accessible for cleaning.

FILLER-CUM-BREATHER

Reservoirs are vented to the atmosphere through an opening that lets air leave or enter the space above the oil as the fluid level rises or falls. A filler-cum-breather unit which can filter air, is used to handle the air flow required to maintain atmospheric pressure whether the tank is full or empty.

PUMP START-UP PROCEDURE PREPARATION PRIOR TO START-UP

The reservoir and the pipe lines should be cleaned properly prior to filling with fluid.

FLUSHING

The reservoir should be filled with filtered hydraulic oil to a sufficient level to prevent vortexing at the suction connection to pump inlet. It is recommended to clean the system by flushing and filtering, using an external pump.

Before putting the oil into the system, the user must clean it accurately. It is recommended to fill the reservoir using mobile filtration units.

FILLING AND REMOVING AIR

If the pump is mounted above the oil level, it should be filled with the oil through the outlet port. If the pump is mounted below the fluid level, the pump outlet fitting can be loosened to allow fluid to displace the air. It is desirable to loosen the fill cap on the reservoir to allow the flow freely. When a solid stream of fluid without air begins to drain through the fitting, then it should be retightened.

An air bleed valve in the outlet line of the system is recommended to remove trapped air. The pump should be filled with oil before start-up, if this device is used.

Note :- The pump should not be operated with the outlet pressure lower than the inlet pressure.

PUMP START-UP

The pump should be always started on no load condition. Start the engine and run the pump in idle condition for approximately five minutes. Once the pump is started, it should prime and pump within a few seconds. If it does not, check for no restrictions between the reservoir and the inlet of the pump and no leaks in the inlet line and connections. Also ensure that trapped air can escape from the outlet.

After smooth run of the pump, start operating the controls of the system. Extend all actuators to maximum safe limit to completely fill the system with fluid.

Ensure that the fluid level is not below the "LOW" limit. In case it is low, add fluid to the reservoir to bring the fluid to the normal fill level.

COLD START

When operating with SAE 10 W oil in the 860 to 54 cSt (4000 to 250 SUS) range, the pressure should be limited to half or less of its rated value until the system is warmed up. For mobile applications, the speed should be also limited to half or less. While starting pumps with fluids greater the 860 cSt (4000 SUS), extreme care should be taken to warm up the entire system including cylinders and motors.

OPERATING TEMPERATURES

Viscosities must not be less than the minimum values shown in below. Temperatures should not exceed 90°C because the expected life of cartridge kits, seals and gaskets will decrease considerably.

For operation at high temperatures, consult Veljan Representative for additional information.

ROTATION

Pumps are offered for clockwise (right hand) rotation or counter clockwise (left hand) rotation. Rotation is viewed from the shaft end of the pump. Irrespective of the direction of rotation, the inlet and outlet ports of the pump remain same.

SEALS

Nitrile seals are standard and suitable for use with petroleum, water-glycol, water-in oil emulsion and high water base fluids. Phosphate ester fluids require the use of special seals.

FLUID SELECTION

Fluid in a hydraulic system performs the multiple functions of transmission of power, lubrication of components and cooling. It is essential in a hydraulic system and proper selection is a necessity for satisfactory operation and life of components.

The basic requirements of a good petroleum oil for hydraulic systems are.

1. Sufficient anti-wear additives
2. Proper viscosity at the operating temperature
3. Adequate rust and oxidation inhibitors

A good quality fluid with high viscosity index and with anti frothing and anti-oxidizing agents conforming to international standards (ie. APIMS, VDMA 248 18, DIN 51524 and 51525) will provide these characteristics.

The oil viscosity should be suitable to the type of hydraulic pumps and motors installed and the operating temperatures of the circuit.

SUCTION PRESSURE AND OPERATING TEMPERATURE REQUIREMENTS

Application	Recommended Operating Suction Pressure range - gauge psi (bar)	Maximum Positive Suction Pressure - gauge psi (bar)	Minimum Suction Pressure - absolute psi (bar)	Maximum Operating Temperature °C
Industrial	0 to 5.0 (0 to 0.31)	20 (1.4)	12.0 (0.83)	66
Mobile			14.5 (1.0)	90

VISCOSITY REQUIREMENTS

Application	Recommended Operating Viscosity Range cSt	Maximum Viscosity at Startup cSt	Minimum Viscosity cSt	
			Continuous	intermittent
Industrial	15 to 54	865	15	10
Mobile			10	6.5

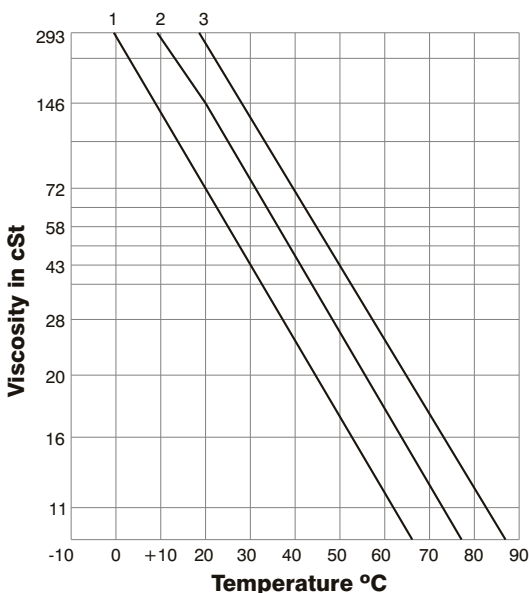

	1	2	3
DIN 51524 standard	H-LP 32	H-LP 46	H-LP 68
Viscosity cSt at 50° C	16-20	24-28	31-39
IP	Hydrus 32	Hydrus 46	Hydrus 68
BP	Energol HLP 32	Energol HLP 46	Energol HLP 68
CASTROL	Hyspin AWS 32	Hyspin AWS 46	Hyspin AWS 32
ESSO	Nuto H 32	Nuto H 46	Nuto H 68
SHELL	Tellus 32	Tellus 32	Tellus 32
CHEVRON	EP Hydraulic Oil 32	EP Hydraulic Oil 32	EP Hydraulic Oil 32
IOC	Servosystem 32	Servosystem 46	Servosystem 68

In the above diagram are shown the typical curves viscosity versus temperature for the commonly used oils. The oils are subdivided in three groups, each one with a different viscosity. In the table below the codes corresponding to different oil manufacturers are indicated.

In general, most hydraulic pumps and motors operate satisfactorily with an oil having a viscosity around 28 cSt at the operating temperature. Since the normal operating temperature of most hydraulic systems is about 50°C, the oil widely used is that corresponding to curve "2" of table having viscosity 24-28 cSt at 50°C.

If the operation temperature exceeds 50° C, an oil having viscosity as per curve "3" and for lower operation temperature an oil having viscosity as per curve "1" are to be used.

In actual usage, less viscous oils (10 cSt) at 50° C or more viscous oil (60-68 cSt) can be used. Please ensure that less viscous oils are used for lower pressure applications (to minimise pressure drop) and more viscous oils for higher pressure applications (to minimise internal leakage). Please note that a too viscous oil can bring more difficulty in the start at ambient temperature and can cause noise and cavitation damages to the pump. In view of this, check the recommendations of the manufacturer of pumps and motors.

The operation temperature has a catalytic action as for the pollution and for the chemical-physical ageing. In particular, the temperature allows the build-up of oxygen compounds and these oxides bring sludge and deposits in the oil.

The recommended operating temperature shall be in the range of 40° to 50° C and should avoid exceeding 70° C as beyond this limit the seals begin to wear faster.

The oil change must be made as a thumb rule for every 3000 hours. It is desirable to analyse oil samples to check its properties (chemical & physical) since the suggested time above is approximate and this depends only on the plant characteristics, operating characteristics, climatic conditions, accuracy of filtration and maintenance.

FIRE RESISTANT FLUIDS

(Phosphate Ester, Water Glycol)

The mineral oils have very low ignition and self combustion temperature. When they ignite, the combustion spreads and hence the danger is more. To prevent fire risk in case of leakage of such fluids, special materials are used which have great resistance to fire.

For Phosphate Ester Fluids, the installation should comply with :

- Suitable seals and flexible pipes (preferably Viton or PTFE)
- Inside surfaces of the reservoir and surfaces that can be in contact with the fluid need not be painted.
- Accurate and continuous filtration of the circuit due to higher fluid density.
- Ample sizing of components and pipings due to higher kinematic viscosity.

These fluids allow very high operation temperatures (even 100° C). They have high resistance and hence do not require special maintenance except frequent check of the water content. For Water-Glycol fluids (compound mixed with water 40 to 50% and ethylene or propylene glycol or polyethylene glycol), the combustion resistance is due to water content.

The installations for water glycol fluids should comply with :

- Suitable seals
- Not painting the inside surface of the reservoir
- Bigger size of the reservoir (generally 10 times the pump delivery)
- Efficient temperature control of the oil
- Reduction of pump speed (1000 to 1200 rpm)
- Reduction of rated pressure 1000 - 1300 psi (70-90 bar)
- Limited flow speed (max 3m/sec)

FILTRATION

The filtering function must eliminate the particles and micro particles that circulate in the system to ensure maximum efficiency and long life of the components.

The selection of the characteristics of the filter is based on the operating requirements and the components that need to be protected.

The normal ratings of filtration is as under :

- For industrial plants - 25 μ rating
- For system equipped with proportional valves - min. 5 μ

The location of the filter in the system should be such that they are easily accessible for periodical cleaning. Filters with visual or electric clogging indicators are generally proffered for better control.

