

# IPH 5

Standard design

www.khadamathydraulic.com  
 Tell: 021-55882749  
 Tell: 021-33488178  
 Fax: 021-33488105

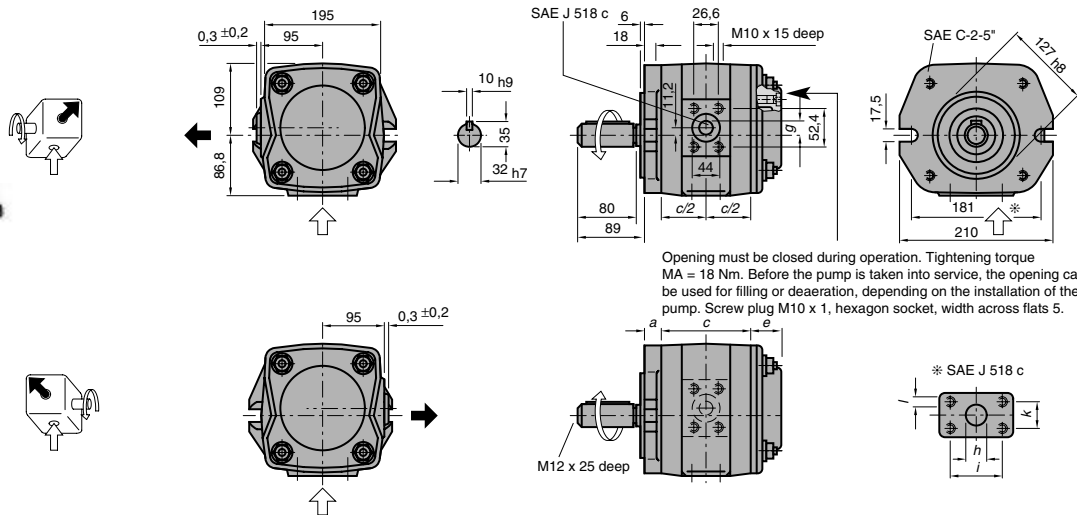

Weight and dimensions										
	a	b	c	e	g	h	i	k	l	kg
IPH 5 – 40	22	55	138	35	24	35	70	36	M 12 x 19 deep	26.8
IPH 5 – 50	22	55	145	35	27	42	70	36	M 12 x 19 deep	28.3
IPH 5 – 64	22	55	155	35	29	42	70	36	M 12 x 19 deep	30

SAE flange no.	
↑	↓
12	14
12	14
12	14

Performance data as per page 5  
 For SAE suction and discharge flanges see page 22

Type	Size	Suction port radial Sense of rotation	Mounting flange SAE-2-hole flange	Alternative: SAE-4-hole flange	Shaft end
IPH 5	40				
	50				
	64				

Ordering-code