

IPC 6

Standard design

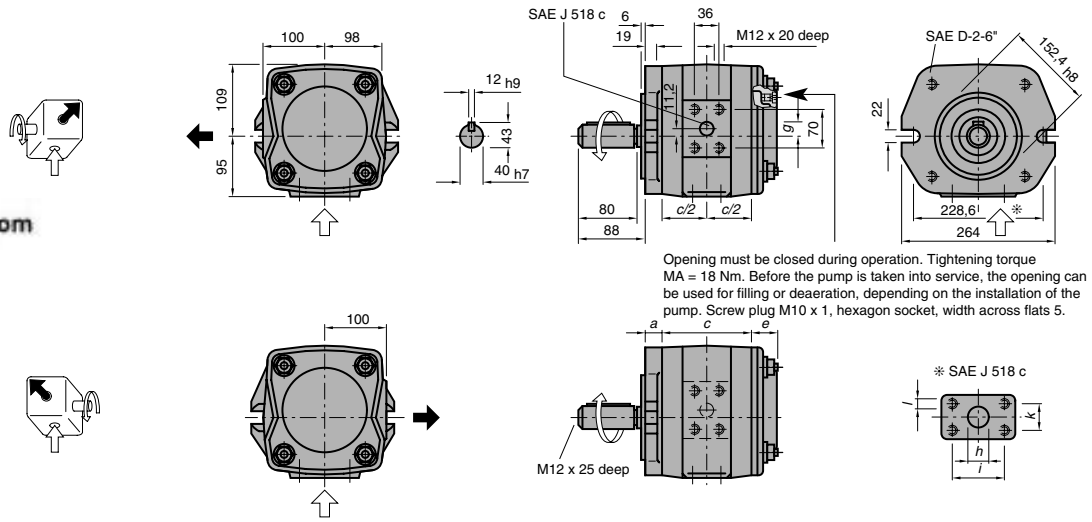

www.khadamathydraulic.com
 Tell: 021-55882749
 Tell: 021-33488178
 Fax: 021-33488105



Weight and dimensions										
	<i>a</i>	<i>b</i>	<i>c</i>	<i>e</i>	<i>g</i>	<i>h</i>	<i>i</i>	<i>k</i>	<i>l</i>	<i>kg</i>
IPC 6 – 80	22	59	148	35	23	45	77.8	42.9	M 12 x 20	30.7
IPC 6 – 100	22	59	158	35	27	50	77.8	42.9	M 12 x 20	32.6
IPC 6 – 125	22	59	170	40	30	50	77.8	42.9	M 12 x 20	35.0

SAE flange no.	
↑	↓
14	15
14	15
14	15

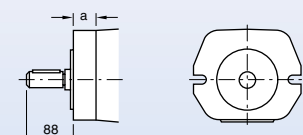
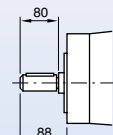
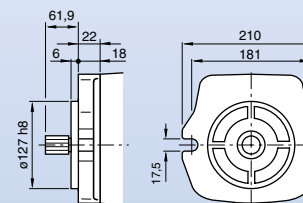
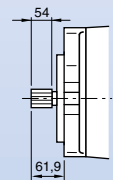
Performance data as per page 5
 For SAE suction and discharge flanges see page 22.
 With pressures exceeding 210 bar, only use Voith flange
 no. 14 or other permissible pressure flange.

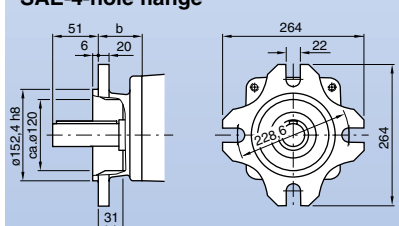
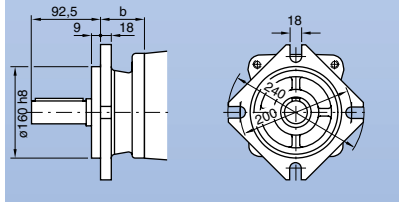
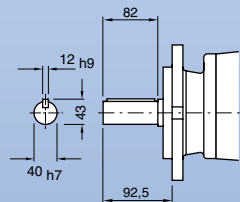
Type	Size	Sense of rotation	Mounting flange	Shaft end
IPC 6	80	 1	SAE-2-hole flange  Dimensions as above 0 1	 Dimensions as above
	100		Alternatives: SAE-2-hole flange for splined shaft  Direct mounting on equipment with SAE connection. 7 0	 Involute splines ANSI B92 1a 17 T 12/24 DP 30°
	125	 6		
		SAE-4-hole flange  Dimensions as above 1 1		
			VDMA 24560 DIN ISO 3019/2 4-hole flange  Dimensions as above 5 1	 Dimensions as above
Ordering-code				