

IPC 7

Standard design

www.khadamathydraulic.com
 Tell: 021-55882749
 Tell: 021-33488178
 Fax: 021-33488105

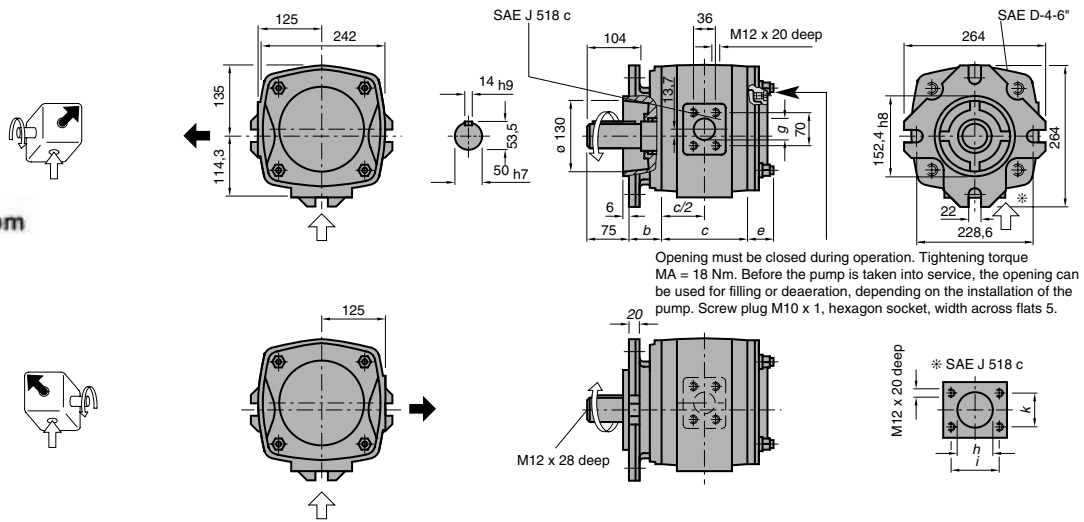

Weight and dimensions

	a	b	c	e	g	h	i	k	l	kg
IPC 7 – 160	–	63	162	48	30	56	89	50.8	M 12 x 20	50
IPC 7 – 200	–	63	174	46	34	62	89	50.8	M 12 x 20	54
IPC 7 – 250	–	63	188	42	38	72	106.3	62	M 16 x 25	59

SAE flange no.

SAE flange no.	SAE flange no.
14	16
14	16
14	17

Performance data as per page 5
 For SAE suction and discharge flanges see page 22.
 Observe permissible operating pressures for pressure flanges.

Type	Size	Sense of rotation	Mounting flange	Shaft end
IPC 7	160		SAE-4-hole flange 	
	200		Alternatives: VDMA 24560 DIN ISO 3019/2 4-hole flange 	
	250			SAE-4-hole flange

Ordering-code