

SINGLE VANE PUMP TYPE VK-20 Y VQ-20

DIMENSIONS IN MILLIMETERS. 1" = 25,4 mm

	FLOW							SPEED (rpm)		PRES (BAR)		CONNECTION		WEIGHT (Kgs.)
	Lts.at 1000 rpm	8	18	27	29	36	39	46	Min.	Max.	Contin.	Intermit.	Inlet	
Gal.at 1200 rpm	2	5	8	9	11	12	14	600	2500	175	210	Ø 1 1/2"	Ø 3/4"	12

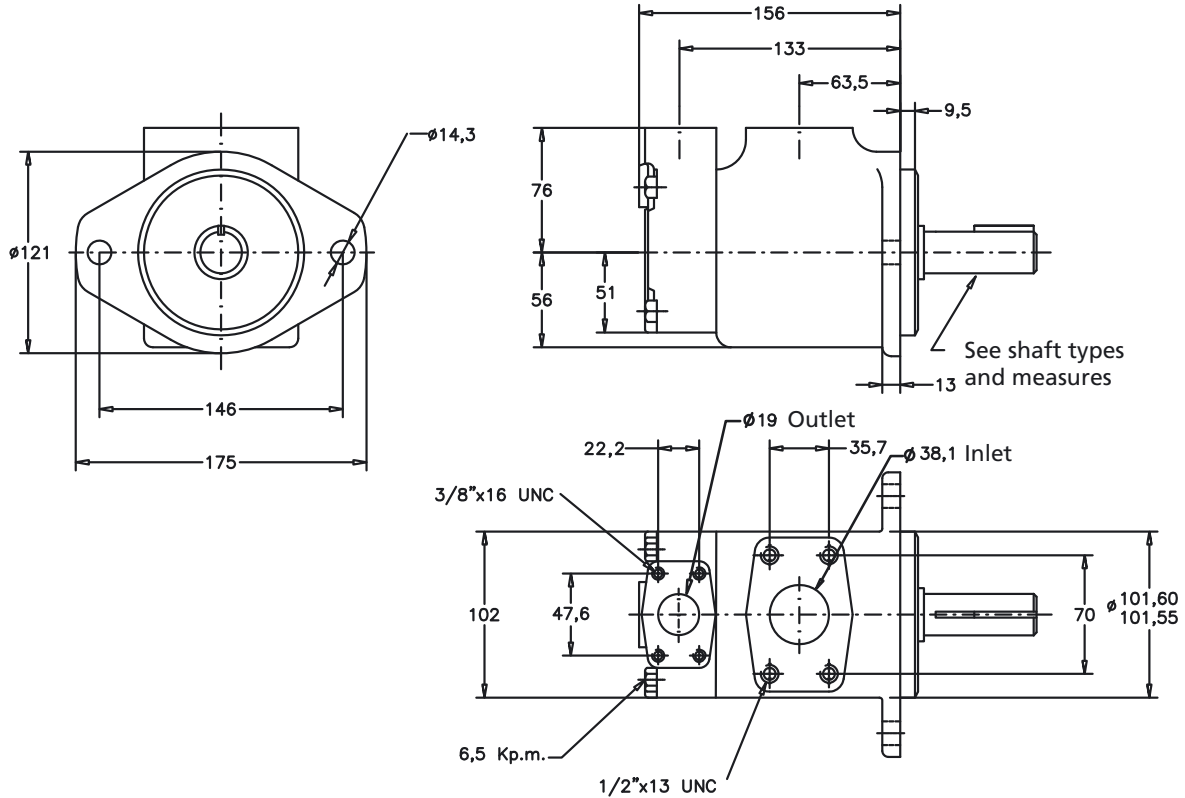

N°1 Shaft

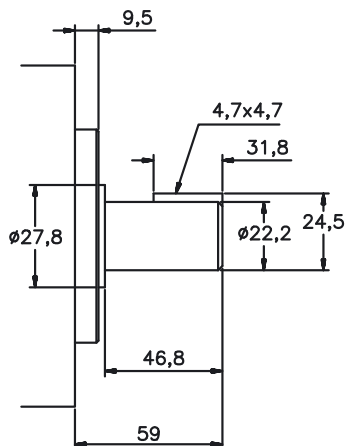

N°151 Shaft

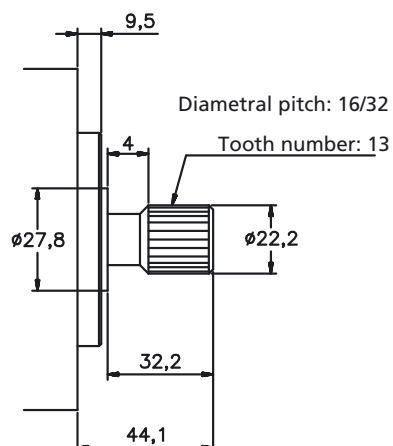

SINGLE VANE PUMP TYPE VK-20 Y VQ-20



FLOW AND INPUT POWER DIAGRAMS

----- Max. pressure (210 bar) _____ Min. Pressure (7 bar)

