

DT6 DOUBLE VANE PUMPS ORDERING CODE

DATA SHEET

DT6* - CC - * - B - 17/14 - 1 - R - 00 - B - 1 - 00

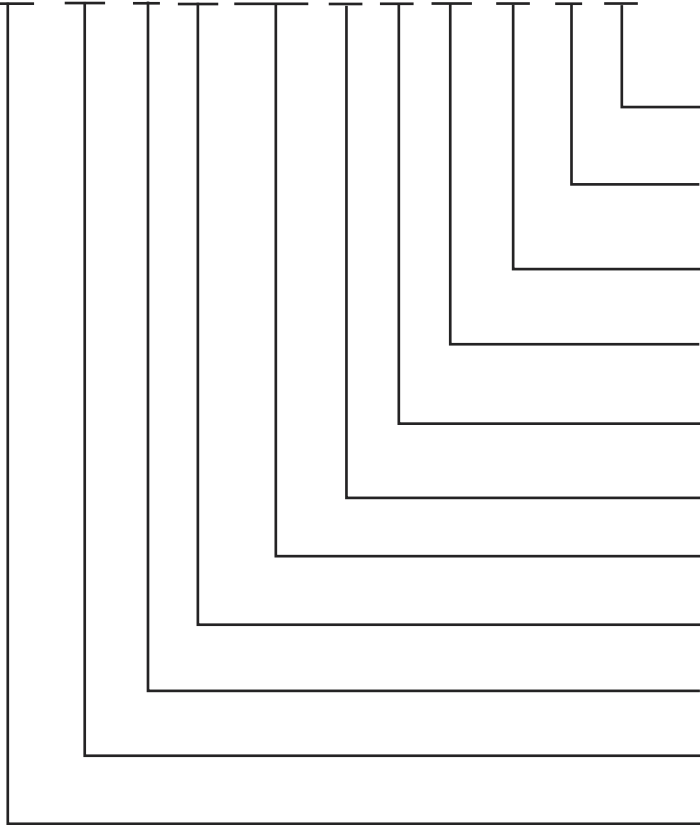

- Special threads (ask for available threads)
 UNC: 00, 01, 10, 11
 Metric: 0M, W0, 1M, W1
- Seal Class 1: NBR
 5: VITON
- Design letter
- Porting combination (see diagrams)
 (Viewed from shaft)
- Direction of rotation R: clockwise
 L: counterclockwise
- Type of Shaft (see particular pump model)
- Flow(see particular pump model)
- Bidirectional
 M: 1 shaft seal
 P: 2 shaft seals
 *: special shafts only
- Size (CC, DC, EC, ED)
- Vane pumps "DT6" series

GENERAL CHARACTERISTICS

GENERAL CHARACTERISTICS

DOUBLE VANE PUMP S

Pump Model	P1			P2			Maxim. speed*	Minim. speed	Front flange standard SAE j744c ISO 3019-1	Weight Kgs	SAE 4 Holes flange		
	Cartridge Model	Theoretical displacement Cm ³ /rev	Maxim. Pressure Bar	Cartridge Model	Theoretical displacement Cm ³ /rev	Maxim. Pressure Bar					Suction S	Pressure	
												P1	P2
DT6CC/M	003 a 031	10.8 a 100	275	003 a 031	10.8 a 100	275	2800	500	SAE B	26	2 1/2" 6 3/8"	1" 1" 6 3/4"	
DT6DC/M	014 a 061	47.6 a 190.5	240	003 a 031	10.8 a 100	275	2800	500	SAE C	37	3" 1 1/4"	1" 1"	
DT6EC/M	042 a 085	132.3 a 269.8	240	003 a 031	10.8 a 100	275	2200	500	SAE C	55	3 1/2" 1 1/2"	1" 1"	
DT6ED/M	042 a 085	132.3 a 268.8	240	014 a 061	47.6 a 190.5	240	2200	500	SAE C	66	4" 1 1/2"	1" 1"	

***IMPORTANT** C - 025,028,031 - 2500 rpm maximum 028,031 - 210 bar max intermittent
D - 042,045,050 - 2200 rpm maximum 050 - 210 bar maximum intermittent - 061 - 120 bar maximum intermittent
E - 085 - 2000 rpm maximum - 90 bar maximum intermittent
See page 41 for further information about speed and pressure

Above mentioned values of maximum speed and maximum pressure are based on use of antiwear oil only. Please contact TDZ for particular values when different fluids are used, (synthetic fluids, water in oil emulsions, water glycol, etcetera)

DOUBLE VANE PUMPS - PORTING COMBINATION

DT6CC-DT6DC-DT6EC

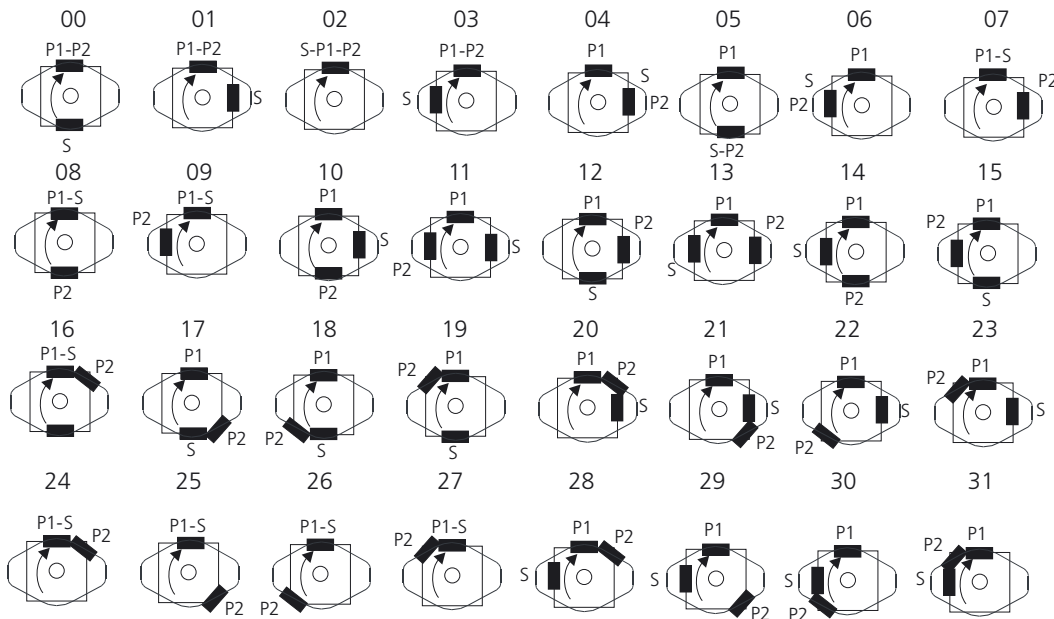

DOUBLE VANE PUMPS - PORTING COMBINATION

DT6ED

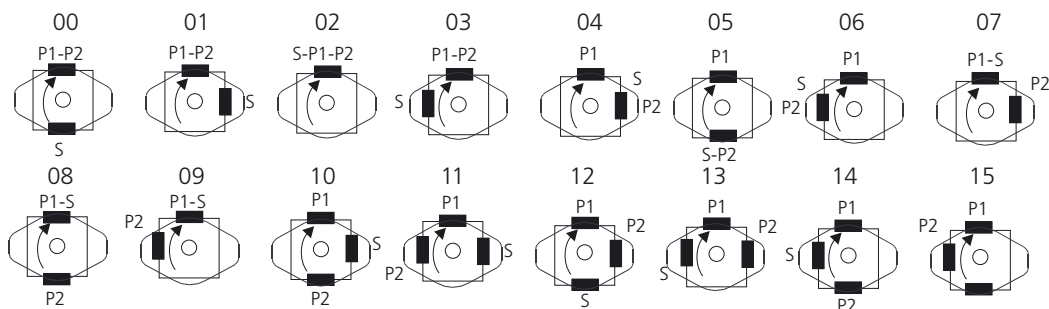

S= Suction port | P1= Shaft end pressure port | P2= Cover end pressure port

DOUBLE PUMPS DT6CC - OPERATING CHARACTERISTICS

DATA SHEET

SHAFT END SECTION

FLOW													SPEED (rpm)		PRESSURE (bar)		
													Mín.	Máx.	Intermit.	Contin.	
Lts/min.at 1000 rpm	11	17	21	26	34	37	46	58	64	70	79	89	100				
Gal/min.at 1200 rpm	3	5	6	8	10	12	14	17	20	22	25	28	31	500	2800*	275	240*

* See page 41 for further information about speed & pressure.

COVER END SECTION

FLOW													SPEED (rpm)		PRESSURE (bar)		
													Mín.	Máx.	Intermit.	Contin.	
Lts/min.at 1000 rpm	11	17	21	26	34	37	46	58	64	70	79	89	100				
Gal/min.at 1200 rpm	3	5	6	8	10	12	14	17	20	22	25	28	31	500	2800*	275	240*

* See page 41 for further information about speed & pressure.

DT6CC - FLOW & INPUT POWER DIAGRAMS

SHAFT END

See **DT6C** Single Pumps for flow and input power diagrams (page 42)

COVER END

See **DT6C** Single Pumps for flow and input power diagrams (page 42)

DT6DC - OPERATING CHARACTERISTICS

DATA SHEET

SHAFT END SECTION

FLOW											SPEED (rpm)		PRESSURE (bar)		
Lts/min.at 1000 rpm	48	66	80	90	98	111	120	136	146	158	191	Mín.	Máx.	Intermit.	Contin.
Gal/min.at 1200 rpm	14	20	24	28	31	35	38	42	45	50	61	500	2500*	240	210

* See page 41 for further information about speed & pressure.

COVER END SECTION

FLOW											SPEED (rpm)		PRESSURE (bar)				
Lts/min.at 1000 rpm	11	17	21	26	34	37	46	58	64	70	79	89	100	Mín.	Máx.	Intermit.	Contin.
Gal/min.at 1200 rpm	3	5	6	8	10	12	14	17	20	22	25	28	31	500	2800*	275	240*

* See page 41 for further information about speed & pressure.

DT6DC - FLOW & INPUT POWER DIAGRAMS

SHAFT END

See **DT6D** Single Pumps for flow and input power diagrams (page 44)

COVER END

See **DT6D** Single Pumps for flow and input power diagrams (page 42)



DOUBLE PUMPS DT6DC - DIMENSIONS

DIMENSIONS IN MILLIMETERS. 1" = 25,4 mm

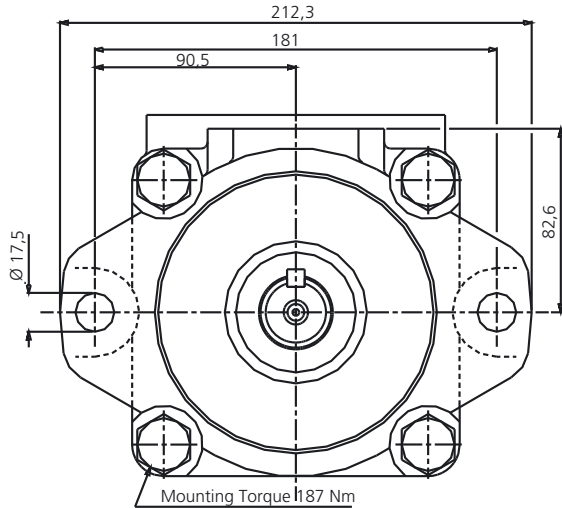

Mounting Torque 187 Nm

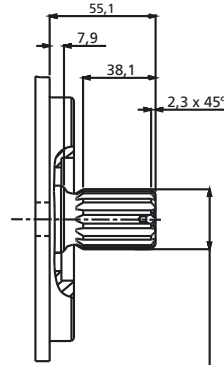

Shaft Code 3

SAE C Splined shaft
1-J498b 12/24 d.p. -
14 Teeth
30° Pressure angle

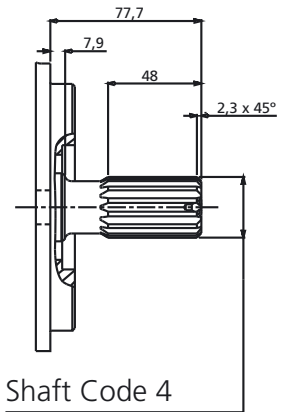

Shaft Code 4

Splined no SAE shaft
1-J498b 12/24 d.p. -
14 Teeth
30° Pressure angle

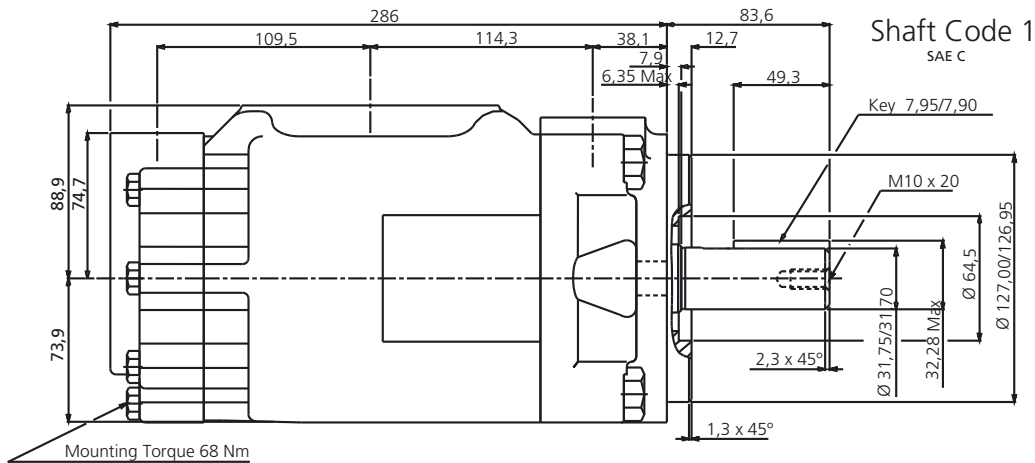

Mounting Torque 68 Nm

Shaft Code 1

SAE C

Key 7,95/7,90

Mounting W/connection variables				
Port	Code	A	B	C
P2	00 & M0	52,4	26,2	25,4
P2	01 & M1	47,6	22,2	19,0

Shaft Torque Limits (cc/rev x bar)		
Pumps	Shaft code	V x P max (P1+P2)
DT6DC	1	43240
	2	38996

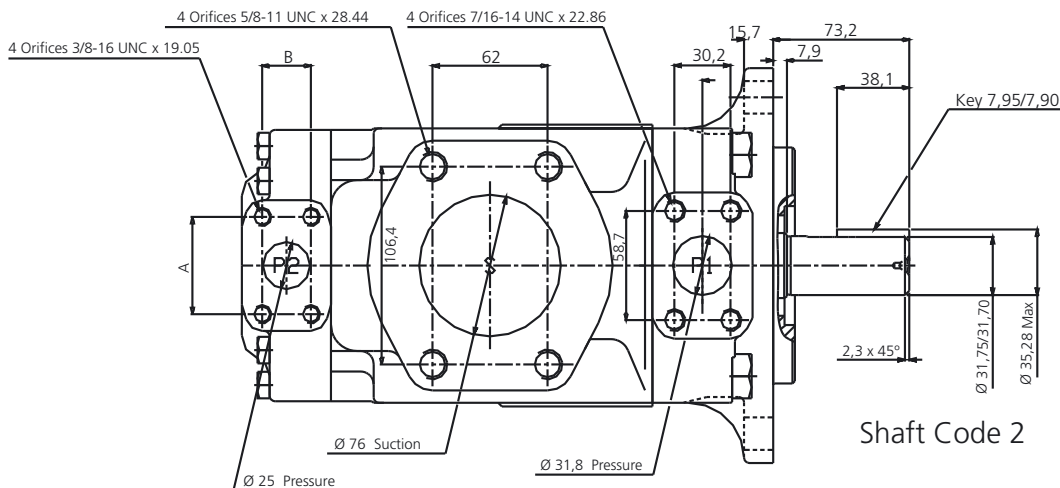

Shaft Code 2

DT6EC - OPERATING CHARACTERISTICS

DATA SHEET

SHAFT END SECTION

	FLOW								SPEED (rpm)		PRESSURE (bar)	
	Lts/min.at 1000 rpm	132	142	156	165	197	213	227	270	Min.	Máx.	Intermit.
Gal/min.at 1200 rpm	42	45	50	52	62	66	72	85	500	2200*	240	210

* See page 41 for further information about speed & pressure.

COVER END SECTION

	FLOW												SPEED (rpm)		PRESSURE (bar)		
	Lts/min.at 1000 rpm	11	17	21	26	34	37	46	58	64	70	79	89	100	Min.	Máx.	Intermit.
Gal/min.at 1200 rpm	3	5	6	8	10	12	14	17	20	22	25	28	31	500	2800*	275	240*

* See page 41 for further information about speed & pressure.

DT6EC - FLOW & INPUT POWER DIAGRAMS

SHAFT END

See **DT6E** Single Pumps for flow and input power diagrams (page 46)

COVER END

See **DT6C** Single Pumps for flow and input power diagrams (page 42)

DOUBLE PUMPS DT6EC - DIMENSIONS

DIMENSIONS IN MILLIMETERS. 1" = 25,4 mm

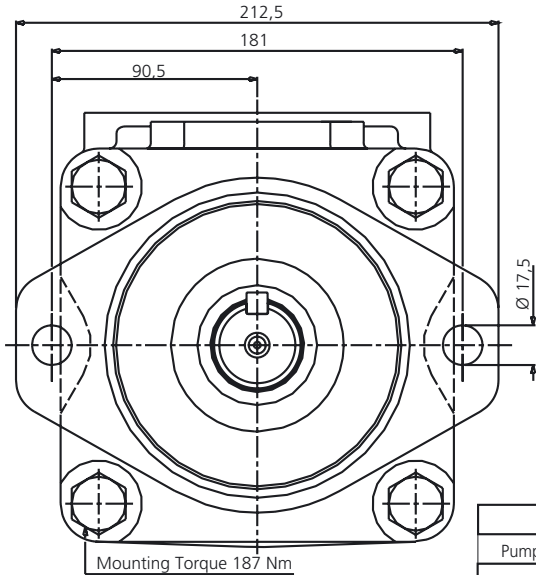

Mounting Torque 187 Nm

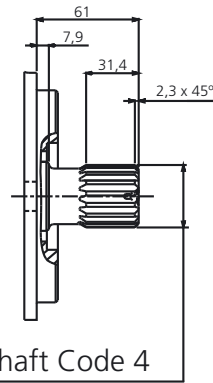

Shaft Code 4

SAE CC Splined shaft
1-J498b 12/24 d.p. -
17 Teeth
30° Pressure angle

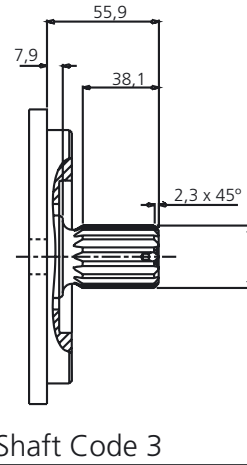

Shaft Code 3

SAE C Splined shaft
1-J498b 12/24 d.p. -
14 Teeth
30° Pressure angle

Shaft Torque Limits (cc/rev x bar)		
Pump	Shaft Code	V x P max (P1+P2)
DT6EC	1	72306
	2	34590
	3	61200

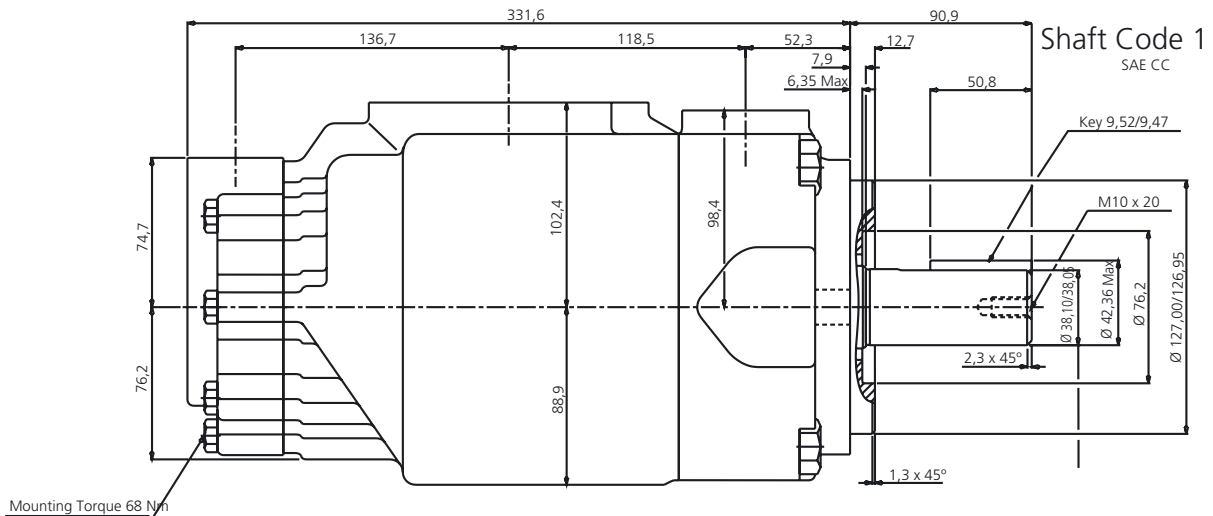

Mounting Torque 68 Nm

Shaft Code 1

SAE CC

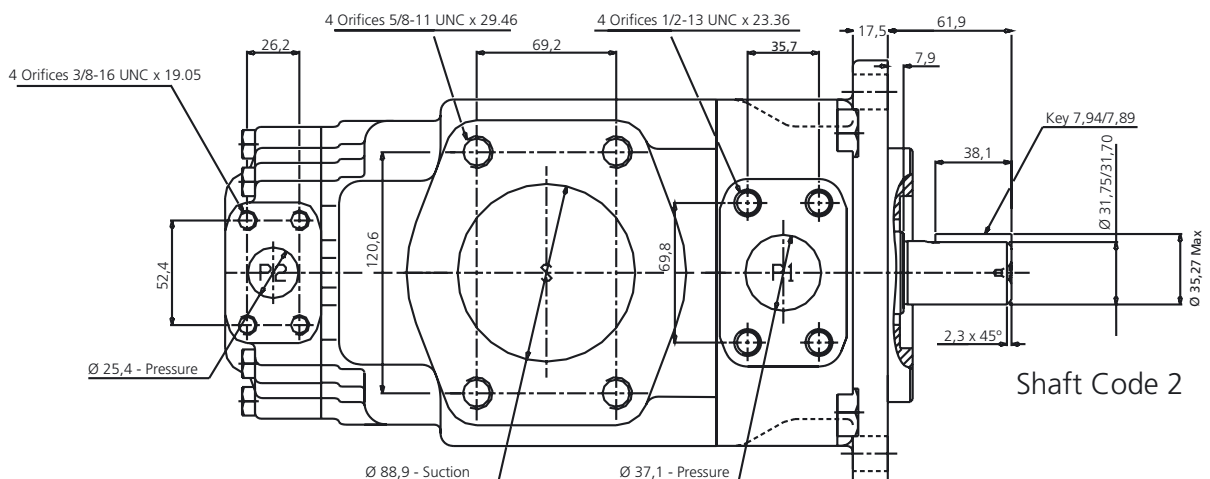

Shaft Code 2

DT6ED - OPERATING CHARACTERISTICS

DATA SHEET

SHAFT END SECTION

FLOW										SPEED (rpm)		PRESSURE (bar)		
Lts/min.at 1000 rpm	132	142	156	165	197	213	227	270			Mín.	Máx.	Intermit.	Contin.
Gal/min.at 1200 rpm	42	45	50	52	62	66	72	85			500	2200*	240	210

* See page 41 for further information about speed & pressure.

COVER END SECTION

FLOW											SPEED (rpm)		PRESSURE (bar)		
Lts/min.at 1000 rpm	48	66	80	90	98	111	120	136	146	158	191	Mín.	Máx.	Intermit.	Contin.
Gal/min.at 1200 rpm	14	20	24	28	31	35	38	42	45	50	61	500	2500*	240	210

* See page 41 for further information about speed & pressure.

DT6ED - FLOW & INPUT POWER DIAGRAMS

SHAFT END

See **DT6E** Single Pumps for flow and input power diagrams (page 46)

COVER END

See **DT6D** Single Pumps for flow and input power diagrams (page 44)

DOUBLE PUMPS DT6ED - DIMENSIONS

DIMENSIONS IN MILLIMETERS. 1" = 25,4 mm

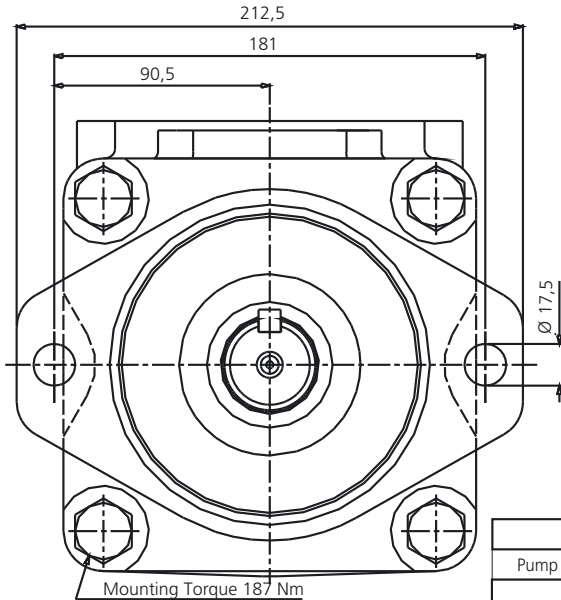

Mounting Torque 187 Nm

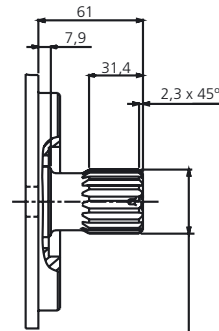

Shaft Code 4

SAE CC Splined shaft
1-J498b 12/24 d.p. -
17 Teeth
30° Pressure angle

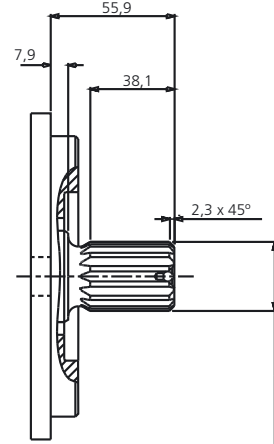

Shaft Code 3

SAE C Splined shaft
1-J498b 12/24 d.p. -
14 Teeth
30° Pressure angle

Shaft Torque Limits (cc/rev x bar)		
Pump	Shaft Code	V x P max (P1+P2)
DT6ED	1	72306
	2	34590
	3	61200

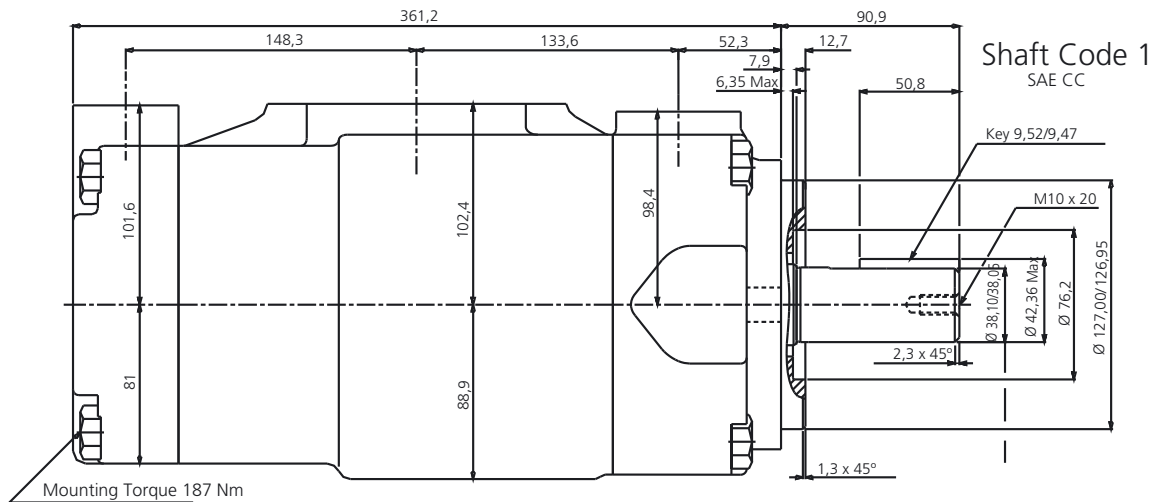

Mounting Torque 187 Nm

Shaft Code 1
SAE CC

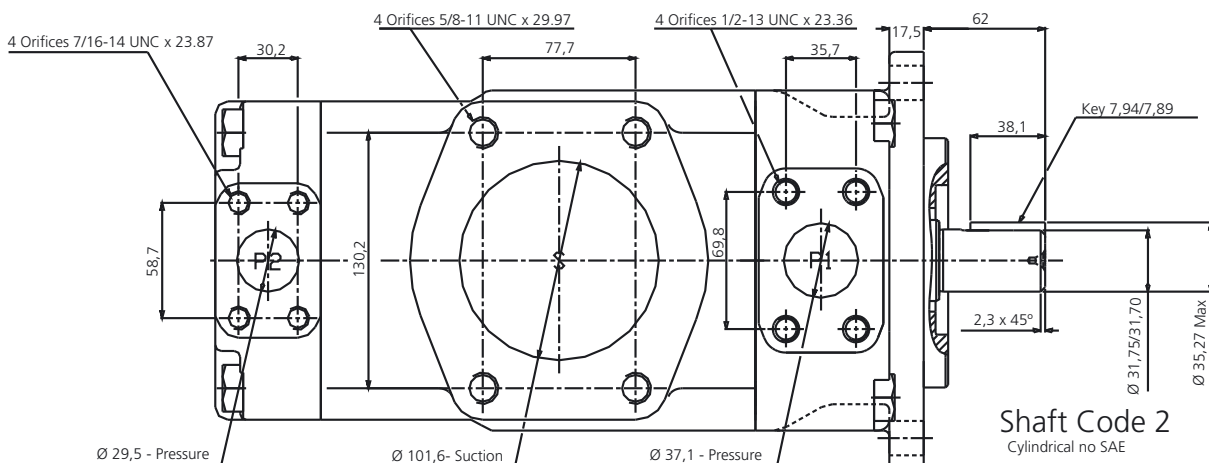

Shaft Code 2
Cylindrical no SAE