

# SERVO VALVES

## PILOT OPERATED FLOW CONTROL VALVES WITH ANALOG INTERFACE

78 SERIES  
STANDARD AND HIGH RESPONSE VERSIONS



Rev. M, March 2013

HIGH PERFORMANCE, FLOW CONTROL  
IN A SIMPLE, DEPENDABLE, RUGGED  
AND LONG-LIFE DESIGN

Whenever the highest levels of motion control performance and design flexibility are required, you'll find Moog expertise at work. Through collaboration, creativity and world-class technological solutions, we help you overcome your toughest engineering obstacles. Enhance your machine's performance. And help take your thinking further than you ever thought possible.

## TABLE OF CONTENTS

INTRODUCTION.....	2
Product Overview .....	3
Features and Benefits.....	4
Description of operation.....	5
TECHNICAL DATA .....	6
78 Series - Standard Response Servo Valves.....	6
78 Series - High Response Servo Valves .....	8
Electrical data.....	10
Installation Drawings and Null Adjust Instructions.....	11
78 Series Hole Pattern for Mounting Surface....	13
BACKGROUND .....	14
Null Flow Adjustment .....	14
Flow calculation.....	15
Null Cut Options .....	15
Related Products .....	16
Routine Maintenance Guidelines .....	17
About Moog.....	18
ORDERING INFORMATION.....	20
Accessories and Spare Parts.....	20
Ordering Code .....	21



This catalog is for users with technical knowledge. To ensure all necessary characteristics for function and safety of the system, the user has to check the suitability of the products described herein. The products described herein are subject to change without notice. In case of doubt, please contact Moog.

Moog is a registered trademark of Moog Inc. and its subsidiaries. All trademarks as indicated herein are the property of Moog Inc. and its subsidiaries. For the full disclaimer refer to [www.moog.com/literature/disclaimers](http://www.moog.com/literature/disclaimers).

For the most current information, visit [www.moog.com/industrial](http://www.moog.com/industrial) or contact your local Moog office.

## PRODUCT OVERVIEW

The 78 series is part of the Moog family of Mechanical Feedback (MFB) Servo Valves. They are throttle valves for 3 and 4 way applications. This series has a high performance, two-stage design that covers a range of rated flows from 75 to 150 l/min (20 to 40 gpm) at 35 bar (500 psi) valve drop per spool land. These valves are intended for position, speed, pressure or force control applications that require high dynamic response. The 78 series MFB offers high dynamics, high resolution and low hysteresis due to its low friction double nozzle pilot stage.

The design is simple and rugged for dependable, long life operation. The output stage is a closed center, 4 way sliding spool. The pilot stage is comprised of a symmetrical, double nozzle dry torque motor. The 2<sup>nd</sup> stage spool position is controlled by a carbide tipped feedback wire. The carbide ball on the end of the feedback wire is a mandatory design requirement that ensures high accuracy, reliable operation and long service life. All of our servo valves are known for high accuracy and reliable operation even in the harshest industrial applications.

This family of valves is considered a flow control servo valve with an analog interface, but does not contain integrated electronics. The options in this series include standard and high response, special null (spool) cuts, seal materials and connectors. Intrinsically safe and flameproof designs for use in hazardous environments are also available with specific models certified to FM, ATEX, CSA and TIIS (Asian) standards.

All of our valves are backed by Moog Global Support, our promise to provide world-class repair and maintenance services delivered by our trained technicians. Each valve possesses a long life design, controlled by proven servo valve technology that has an outstanding history of 60 years of meeting the motion control needs of our customers. All of this makes Moog servo valves the best choice for your hydraulic motion control requirements.

	Standard response valves with Ø 0.625 spool			High response valves with Ø 0.406 spool	
<b>Valve design</b>	2-stage, with spool and bushing and dry torque motor				
<b>Mounting pattern</b>	Unique to 78 Series				
<b>Maximum operating pressure to ports P, T, A, B</b>	210 bar (3000 psi)				
<b>Maximum flow</b>	208 l/min (54.9 gpm)			156 l/min (41.2 gpm)	
<b>Pilot stage</b>	Nozzle Flapper				
<b>Rated flow at <math>\Delta p_N</math> 35 bar/spool land (500 psi/spool land)</b>	75 l/min (20 gpm)	115 l/min (30 gpm)	150 l/min (40 gpm)	75 l/min (20 gpm)	115 l/min (30 gpm)
<b>Step response time for 0 to 100 % stroke</b>	30 ms		40 ms	15 ms	20 ms



Intrinsically safe valve versions are available for use in hazardous locations. Specific models are certified to FM, ATEX, CSA and TIIS standards. Contact Moog for details.

## FEATURES AND BENEFITS

The 78 Series is proven technology that performs reliably in machines where high performance, stability and accuracy are required. Moog's Mechanical Feedback Valves are designed to provide high reliability and long service life. The current technology reflects over 60 years of experience of servo control in some of the world's most demanding environments.

<b>Features</b>	<b>Benefits</b>
100% factory tested to ensure critical specification performance	Ensures smooth and easy startup, reduces downtime and insures long life in critical industrial applications
2 Stage Design	Enables high machine performance, faster cycle times and greater accuracy - all resulting in higher productivity
Dual Coil torque motor	Redundancy for high reliability
Dual Precision Nozzles in Torque Motor	Precision flow control and predictability
Dry torque motor design	Eliminates potential contamination issues in the air gaps of the torque motor that could cause machine downtime
Hardened 440C Bushing and Spool	Provides for high life, wear resistance when used in the harsh environments; provides for low sliding friction during use
Emergency failsafe positioning	Most valves are set up to return to a failsafe position when the command signal is interrupted or eliminated
Field replaceable pilot stage filter	Enables preventive maintenance in the field, saving precious machine downtime and service costs
External null bias adjustment	Enables technicians to manually adjust the null bias of the valve to adapt to the conditions of the machine (see section on null flow adjustment - Page 14). This feature provides a simple adjustment to machine performance without the need to adjust a controller.

## DESCRIPTION OF OPERATION

The 78 Series Flow Control Servo Valve consists of a polarized electrical torque motor and two stages of hydraulic power amplification. The torque motor armature extends into the air gaps of the magnetic flux circuit and is supported in this position by a flexure tube. The flexure tube acts as a seal between the electromagnetic and hydraulic sections of the valve. The 2 torque motor coils surround the armature, one on each side of the flexure tube.

The flapper of the first stage hydraulic amplifier is rigidly attached to the midpoint of the armature. The flapper extends through the flexure tube and passes between 2 nozzles, creating two variable orifices between the nozzle tips and the flapper. The pilot pressure is controlled by the flapper/nozzle variable orifice and is in turn fed to the end areas of the second stage spool. This action creates a differential pressure from one end of the spool to the other and results in spool displacement. The spool displacement causes a force in the feedback wire which opposes the original input signal torque. Spool movement continues until the feedback wire force equals the input signal force.

The second stage is a conventional four-way spool design in which output flow from the valve, at a fixed valve pressure drop, is proportional to spool displacement from the null position. A cantilever feedback spring is fixed to the flapper and engages a slot at the center of the spool. Displacement of the spool deflects the feedback spring which creates a force on the armature/flapper assembly.

Input signal induces a magnetic charge in the armature and causes a deflection of the armature and flapper. This assembly pivots about the flexure tube and increases the size of one nozzle orifice and decreases the size of the other.

### Electro-hydraulic Servo Valve Cut-away

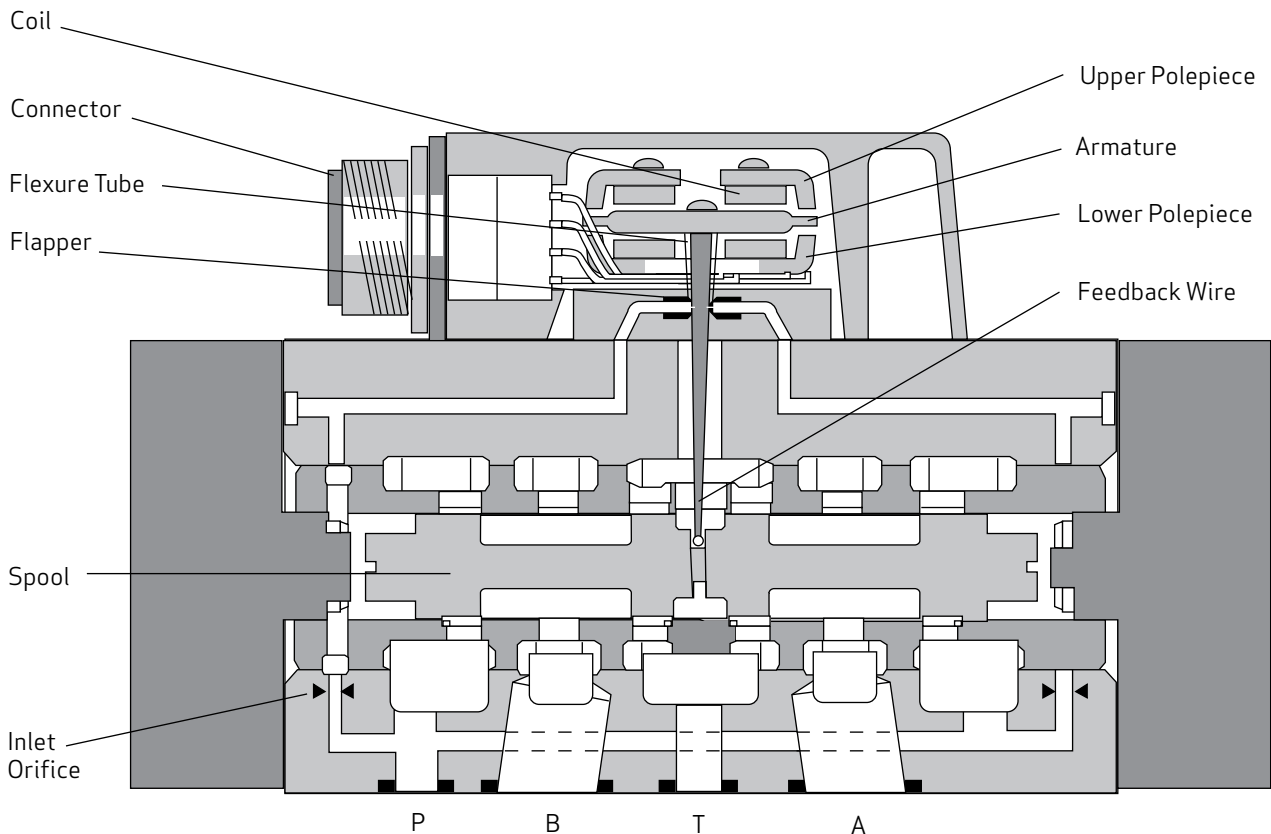

## 78 SERIES - STANDARD RESPONSE SERVO VALVES

### General Technical Data

<b>Valve design</b>	2-stage, with spool and bushing and dry torque motor
<b>Pilot stage</b>	Nozzle Flapper
<b>Mounting pattern</b>	Unique to 78 Series
<b>Installation position</b>	Any orientation, fixed or movable
<b>Weight</b>	2.86 kg (6.3 lb)
<b>Storage temperature range</b>	-40 to +60 °C (-40 to +140 °F)
<b>Ambient temperature range</b>	-40 to +135 °C (-40 to +275 °F)
<b>Vibration resistance</b>	30 g, 3 axis, 10 Hz to 2 kHz
<b>Shock resistance</b>	30 g, 3 axis
<b>Seal material</b>	Fluorocarbon (FKM) 85 Shore D Others upon request

### Hydraulic Data

<b>Maximum operating pressure to ports P, T, A, B</b>	210 bar (3,000 psi)		
<b>Rated flow at <math>\Delta p_N</math> 35 bar/spool land (500 psi/spool land)</b>	75 l/min (20 gpm)	115 l/min (30 gpm)	150 l/min (40 gpm)
<b>Maximum flow</b>	208 l/min (54.9 gpm)		
<b>Null adjust authority</b>	Greater than 10 % of rated flow		
<b>Hydraulic fluid</b>	Hydraulic oil as per DIN 51524 parts 1 to 3 and ISO 11158. Other fluids on request.		
Temperature range	-40 to +60 °C (-40 to +140 °F)		
Recommended viscosity range	10 to 85 mm <sup>2</sup> /s (cSt)		
Maximum permissible viscosity range	5 to 1250 mm <sup>2</sup> /s (cSt)		
<b>Recommended cleanliness class as per ISO 4406</b>			
For functional safety	17/14/11		
For longer service life	15/13/10		
<b>Recommended filter rating</b>			
For functional safety	$\beta_{10} = 75$ (10 $\mu$ m absolute)		
For longer life	$\beta_5 = 75$ (5 $\mu$ m absolute)		

### Static and Dynamic Data

<b>Sample deviation of rated flow</b>	±10 %		
<b>Step response time for 0 to 100 % stroke</b>	30 ms	30 ms	40 ms
<b>Threshold</b>	0.5 %		
<b>Hysteresis</b>	< 3.0 %		
<b>Null shift at <math>\Delta T = 38</math> °C (100 °F)</b>	< 2.0 %		

## 78 SERIES - STANDARD RESPONSE SERVO VALVES

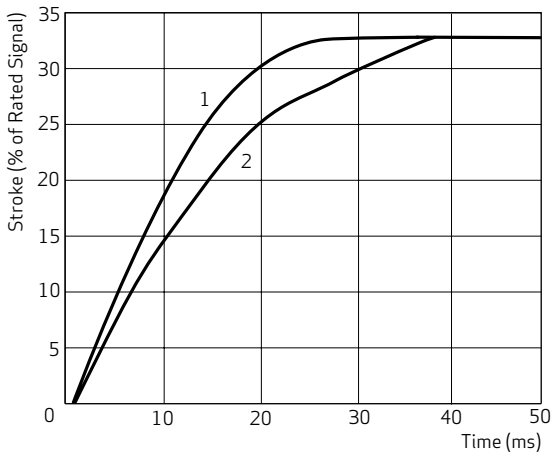

**Reduced Amplitude Step Response**

33 % step  
 Plot 1 = 75/115 l/min (20/30 gpm)  
 Plot 2 = 150 l/min (40 gpm)

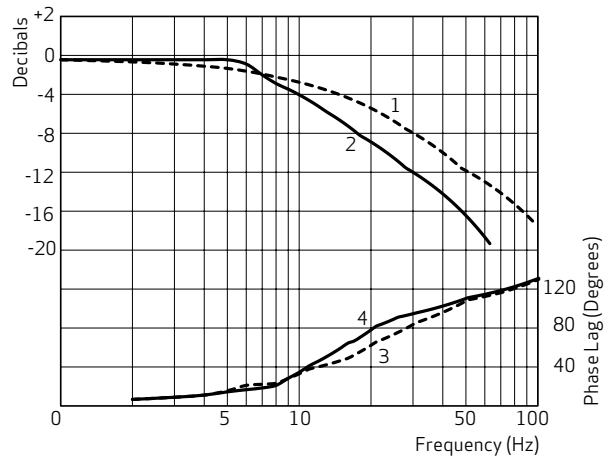

**Standard Frequency Response**

75/115 l/min (20/30 gpm)  
 Plot 1 & 3 =  $\pm 40$  % rated signal  
 Plot 2 & 4 =  $\pm 100$  % rated signal

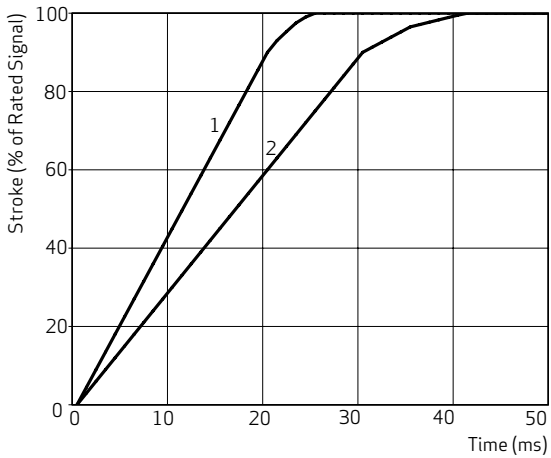

**Full Amplitude Step Response**

100 % step  
 Plot 1 = 75/115 l/min (20/30 gpm)  
 Plot 2 = 150 l/min (40 gpm)

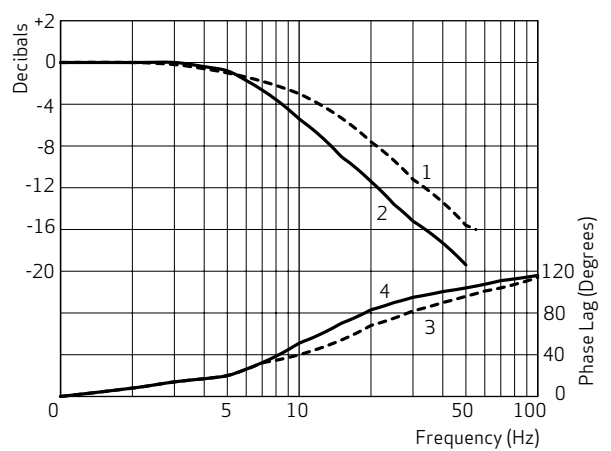

**Standard Frequency Response**

154 l/min (40 gpm)  
 Plot 1 & 3 =  $\pm 40$  % rated signal  
 Plot 2 & 4 =  $\pm 100$  % rated signal

**Note:** Measured with 210 bar (3,000 psi), DTE<sup>®</sup>-24 fluid at +38 °C (+100 °F)

## 78 SERIES - HIGH RESPONSE SERVO VALVES

### General Technical Data

<b>Valve design</b>	2-stage, with spool and bushing and dry torque motor	
<b>Pilot stage</b>	Nozzle Flapper	
<b>Mounting pattern</b>	Unique to 78 Series	
<b>Installation position</b>	Any orientation, fixed or movable	
<b>Weight</b>	2.86 kg (6.3 lb)	
<b>Storage temperature range</b>	-40 to +60 °C (-40 to +140 °F)	
<b>Ambient temperature range</b>	-40 to +135 °C (-40 to +275 °F)	
<b>Vibration resistance</b>	30 g, 3 axis, 10 Hz to 2 kHz	
<b>Shock resistance</b>	30 g, 3 axis	
<b>Seal material</b>	Fluorocarbon (FKM) 85 Shore D Others upon request	

### Hydraulic Data

<b>Maximum operating pressure to ports P, T, A, B</b>	210 bar (3,000 psi)	
<b>Rated flow at <math>\Delta p_N</math> 35 bar/spool land (500 psi/spool land)</b>	75 l/min (20 gpm)	115 l/min (30 gpm)
<b>Maximum flow</b>	156 l/min (41.2 gpm)	
<b>Null adjust authority</b>	Greater than 10 % of rated flow	
<b>Hydraulic fluid</b>	Hydraulic oil as per DIN 51524 parts 1 to 3 and ISO 11158. Other fluids on request.	
Temperature range	-40 to +60 °C (-40 to +140 °F)	
Recommended viscosity range	10 to 85 mm <sup>2</sup> /s (cSt)	
Maximum permissible viscosity range	5 to 1250 mm <sup>2</sup> /s (cSt)	
<b>Recommended cleanliness class as per ISO 4406</b>		
For functional safety	17/14/11	
For longer service life	15/13/10	
<b>Recommended filter rating</b>		
For functional safety	$\beta_{10} = 75$ (10 $\mu$ m absolute)	
For longer life	$\beta_5 = 75$ (5 $\mu$ m absolute)	

### Static and Dynamic Data

<b>Sample deviation of rated flow</b>	±10 %	
<b>Step response time for 0 to 100 % stroke</b>	15 ms	20 ms
<b>Threshold</b>	0.5 %	
<b>Hysteresis</b>	< 3.0 %	
<b>Null shift at <math>\Delta T = 38</math> °C (100 °F)</b>	< 2.0 %	



## 78 SERIES - HIGH RESPONSE SERVO VALVES

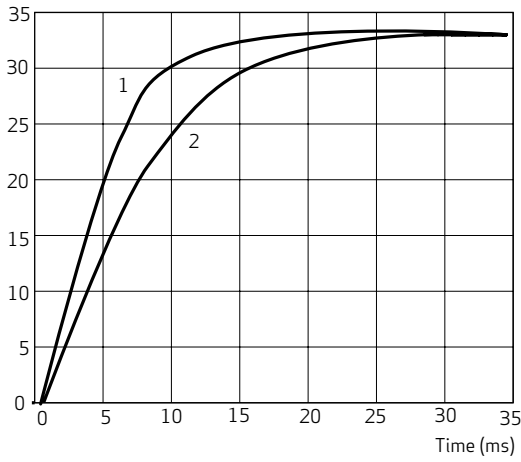

**Reduced Amplitude Step Response**

33 % step  
 Plot 1 = 75 l/min (20 gpm)  
 Plot 2 = 115 l/min (30 gpm)

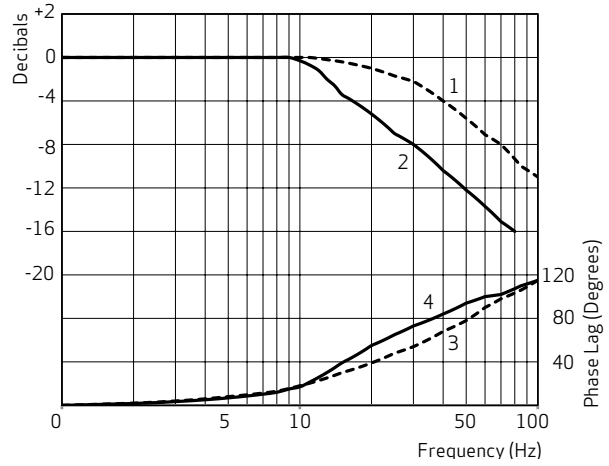

**High Frequency Response**

75 l/min (20 gpm)  
 Plot 1 & 3 = ±40 % rated signal  
 Plot 2 & 4 = ±100 % rated signal

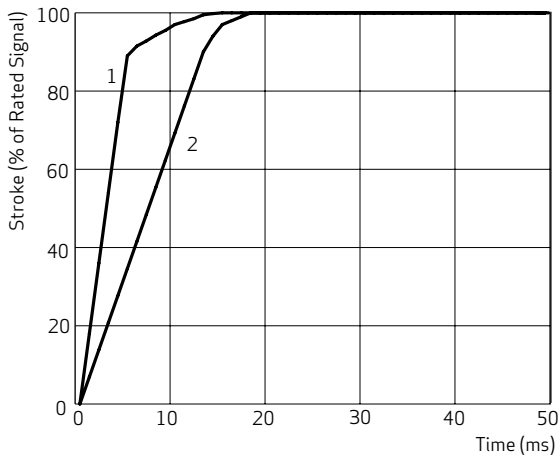

**Full Amplitude Step Response**

100 % step  
 Plot 1 = 75 l/min (20 gpm)  
 Plot 2 = 115 l/min (30 gpm)

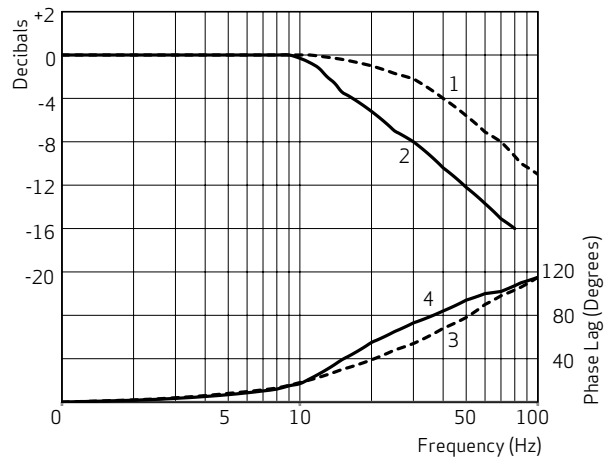

**High Frequency Response**

115 l/min (30 gpm)  
 Plot 1 & 3 = ±40 % rated signal  
 Plot 2 & 4 = ±100 % rated signal

**Note:** Measured with 210 bar (3,000 psi), DTE<sup>®</sup>-24 fluid at +38 °C (+100 °F)

## ELECTRICAL DATA

### Rated current and coil resistance

A variety of coils are available for 78 Series Servo Valves, which offer a wide choice of rated currents.

### Coil impedance

The resistance and inductance of standard coils are given below. The 2 coils in each Servo Valve are wound with equal turns giving a normal production tolerance on coil resistance of  $\pm 12\%$ . Copper magnet wire is used, so the coil resistance will vary significantly with temperature. The effects of coil resistance changes can be essentially eliminated through use of a current feedback servoamplifier having high output impedance.

Inductance is determined under pressurized operating conditions and is greatly influenced by back electromagnetic forces of the torque motor. These effects vary with most operating conditions, and vary greatly with signal frequencies above 100 Hz. The apparent coil inductance values given are determined at 50 Hz.

Ordering code	Recommended rated current [mA]			Coil resistance [Ohms/coil at 25 °C (77 °F)]	Power consumption [W]		
	Command signal				Single coil	Series coil	Parallel coil
	Single coil	Series coil	Parallel coil		Single coil	Series coil	Parallel coil
<b>4</b>	$\pm 8$	$\pm 4$	$\pm 8$	1,000	0.064	0.032	0.032
<b>H</b>	$\pm 15$	$\pm 7.5$	$\pm 15$	200	0.045	0.023	0.023
<b>L</b>	$\pm 40$	$\pm 20$	$\pm 40$	80	0.128	0.064	0.064
<b>Z</b>	$\pm 200$	$\pm 100$	$\pm 200$	22	0.856	0.428	0.428

Ordering code	Approximate coil inductance [H]		
	Measured at 50 Hz		
	Single coil	Series coil	Parallel coil
<b>4</b>	3.2	9.7	2.6
<b>H</b>	0.72	2.2	0.59
<b>L</b>	0.22	0.66	0.18
<b>Z</b>	0.07	0.21	0.06

### Coil connections

A 4-pin electrical connector that mates with an MS3106F14S-2S is standard. All 4 torque motor leads are available at the connector so that external connections can be made for series, parallel, or differential operation. 78 Series Servo Valves can be supplied on special order with other connectors or pigtail.

#### Connection for valve opening $P \rightarrow B, A \rightarrow T$

##### Single

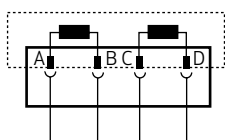

A (+), B (-) or C (+), D (-)

##### Series

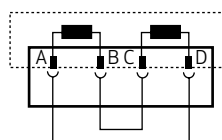

A (+), D (-), B and C connected

##### Parallel

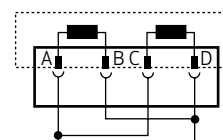

A and C (+), B and D (-)

# INSTALLATION DRAWINGS AND NULL ADJUST INSTRUCTIONS

## Mechanically Adjustable Installation

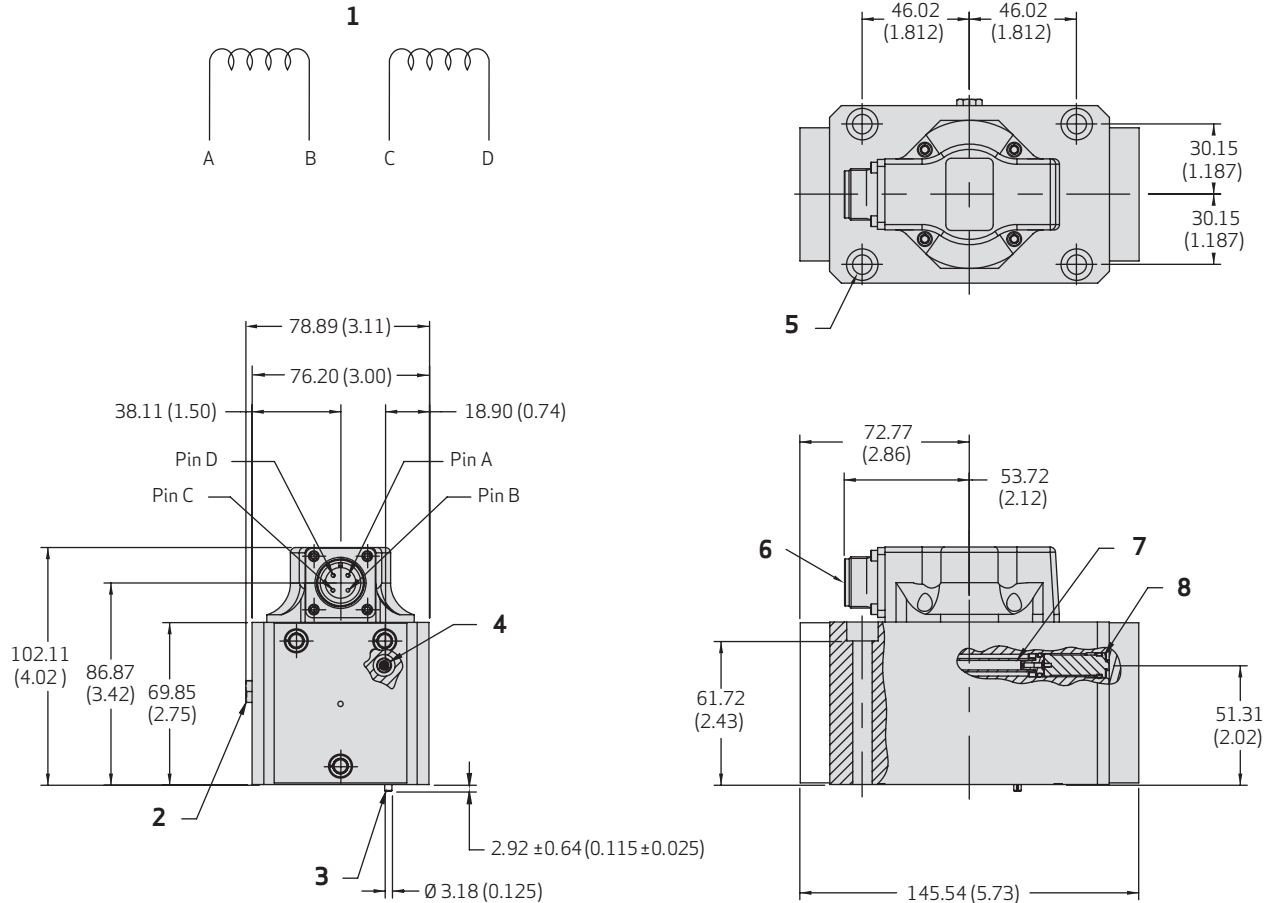

Note: Dimensions in mm (in)

- 1 Typical wiring schematic
- 2 Null adjust screw (requires 3/8" offset wrench and 3/32" Allen wrench)
- 3 Locating pin (refer to section Hole Pattern for positon)
- 4 Filter and plug location

- 5 4 x Ø 8.33 mm (0.328 in) thru Ø 13.51 mm (0.532 in) to depth shown in section Mounting Holes
- 6 Mating connector mates with MS3106-14S-2S (MOOG P/N: -49054F14S2S)
- 7 Filter
- 8 Filter plug

**Notes:**

**Fluid**

Industrial hydraulic fluid per DIN 51524 parts 1 to 3 and ISO 11158, maintained to ISO 4406 Code 17/14/11 recommended. Viscosity 10 to 85 mm<sup>2</sup>/s (cSt) at 38 °C (60 to 300 SUS at 100 °F).

**Operating Temperature Range**

Fluid: -40 to +60 °C (-40 to +140 °F)  
 Ambient: -40 to +135 °C (-40 to +275 °F).

**Valve Phasing**

Flow out port B results when:  
 Series coils: B & C connected, A+, D-  
 Parallel coils: A & C connected, B & D connected, A+/B- or C+/D-  
 Single coils: A+/B- or C+/D-.

**Surface**

Surface to which valve is mounted requires flatness of 0.01 mm (0.004 in) over 100 mm (3.94 in) and an average finish R<sub>a</sub> better the 0.8 µm (0.000032 in).

**Null Adjust**

Flow out port B results with the clockwise rotation of the null adjust screw.

**Port**

14.23mm (0.562 in) Ø counter-bored 17.65 mm (0.695 in) inside Ø by 22.23 mm [0.875 in] outside Ø.

**Recommended Seals**

90 durometer 1.78 mm (0.070 in) cross section, 9.63 mm (0.739 in) inside Ø o-rings. Reference MS28775-18 o-rings to be compatible with the hydraulic fluid.

# INSTALLATION DRAWINGS AND NULL ADJUST INSTRUCTIONS

## Magnetically Adjustable Installation

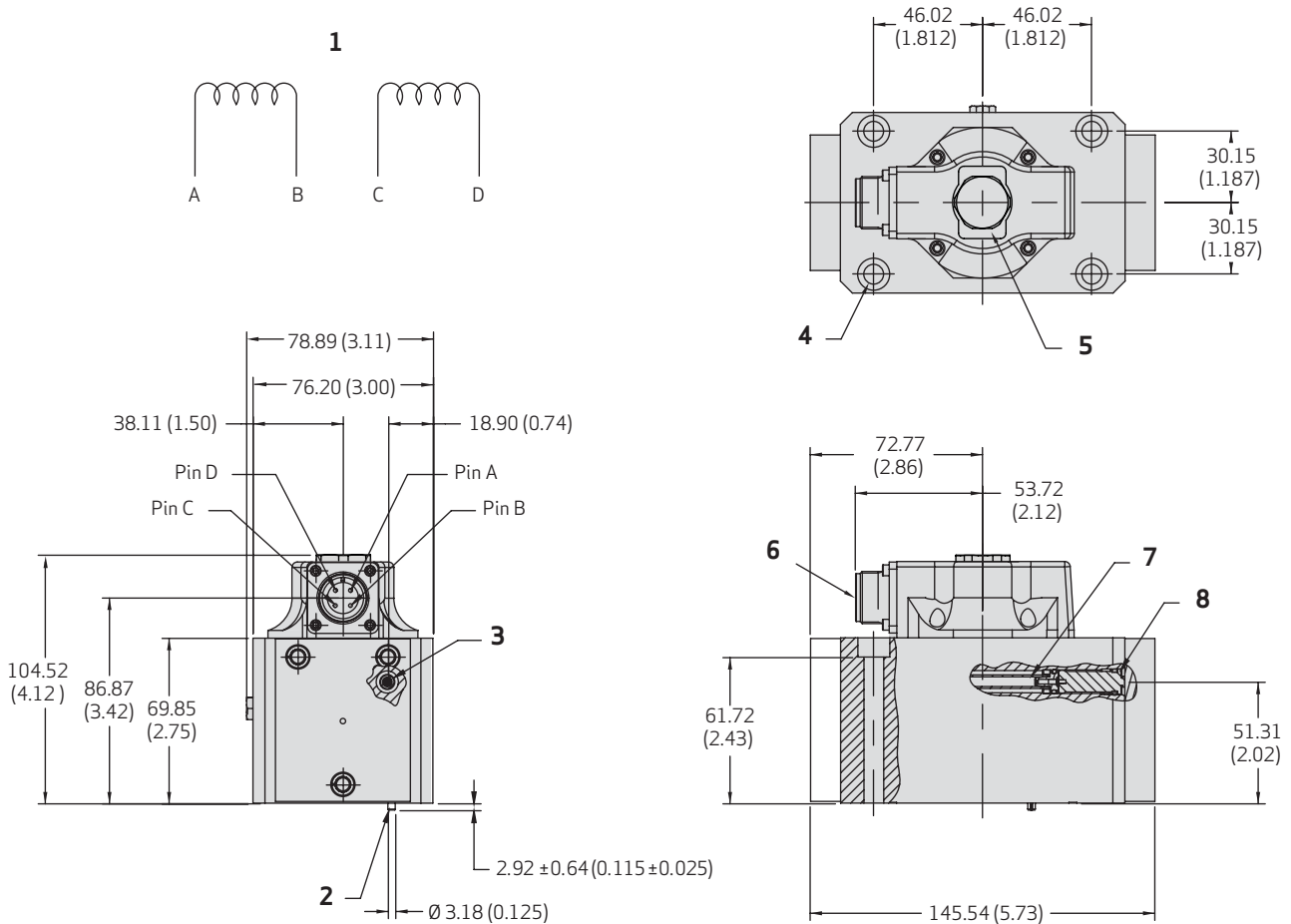

Note: Dimensions in mm (in)

- 1 Typical wiring schematic
- 2 Null adjust screw (requires 3/8" offset wrench and 3/32" Allen wrench)
- 3 Locating pin (refer to section Hole Pattern for position)
- 4 Filter and plug location

- 5 4 x Ø 8.33 mm (0.328 in) thru Ø 13.51 mm (0.532 in) to depth shown in section Mounting Holes
- 6 Mating connector mates with MS3106-14S-2S (MOOG P/N: -49054F14S2S)
- 7 Filter
- 8 Filter plug

### Notes:

#### Fluid

Industrial hydraulic fluid per DIN 51524 parts 1 to 3 and ISO 11158, maintained to ISO 4406 Code 17/14/11 recommended. Viscosity 10 to 85 mm<sup>2</sup>/s (cSt) at 38 °C (60 to 300 SUS at 100 °F).

#### Operating Temperature Range

Fluid: -40 to +60 °C (-40 to +140 °F)  
Ambient: -40 to +135 °C (-40 to +275 °F).

#### Valve Phasing

Flow out port B results when:  
Series coils: B & C connected, A+, D-  
Parallel coils: A & C connected, B & D connected, A+/B- or C+/D-  
Single coils: A+/B- or C+/D-.

#### Surface

Surface to which valve is mounted requires flatness of 0.01 mm (0.004 in) over 100 mm (3.94 in) and an average finish R<sub>a</sub> better than 0.8 µm (0.000032 in).

#### Null Adjust

Flow out port B results with the clockwise rotation of the null adjust screw.

#### Port

14.23mm (0.562 in) Ø counter-bored 17.65 mm (0.695 in) inside Ø by 22.23 mm [0.875 in] outside Ø.

#### Recommended Seals

90 durometer 1.78 mm (0.070 in) cross section, 9.63 mm (0.739 in) inside Ø o-rings. Reference MS28775-18 o-rings to be compatible with the hydraulic fluid.

## 78 SERIES PORT PATTERN

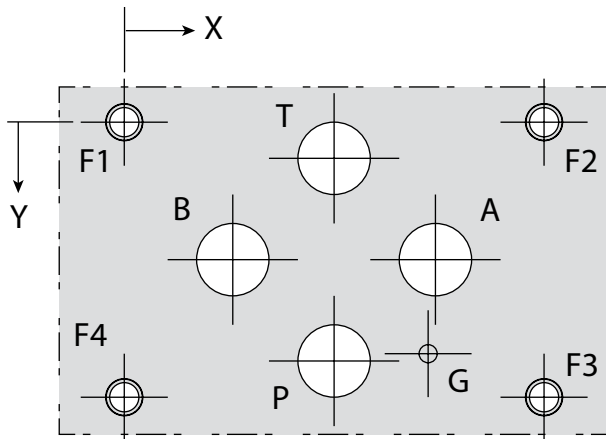

Designation		P	A	B	T	G	F1	F2	F3	F4
Size Ø	mm	15.88	15.88	15.88	15.88	3.96	M8	M8	M8	M8
	in	0.625	0.625	0.625	0.625	0.156	5/16-18	5/16-18	5/16-18	5/16-18
Position X	mm	46.02	68.25	23.80	46.02	66.65	0	92.08	92.08	0
	in	1.812	2.687	0.937	1.812	2.624	0	3.625	3.625	0
Position Y	mm	52.37	30.15	30.15	7.92	50.77	0	0	60.33	60.33
	in	2.062	1.187	1.187	0.312	1.999	0	0	2.375	2.375

### Notes

- Surface:  
Surface to which the valve is mounted requires flatness of 0.01 mm (0.004 in) over 100 mm (3.94 in), and an average finish  $R_a$  better than 0.8  $\mu\text{m}$  (0.000032 in).
- Ports:  
For maximum flow the ports P, T, A, and B must be designed with diameters of 16 mm (0.625 in).
- Recommended seals:  
90 durometer 1.78 mm (0.070 in) cross section, 9.63 mm (0.739 in) inside diameter O-rings. Reference MS28775-18 O-rings to be compatible with the hydraulic fluid.

## NULL FLOW ADJUSTMENT

It is often desirable to mechanically adjust the null bias of the servo valve independently of other system parameters. The external null flow adjustment provides for simple realignment of the mechanical center of the valve with its electrical center. Our adjustment allows an operator to affect the null flow approximately  $\pm 10\%$  by following the procedure below.

We have 2 methods by which we can adjust the null bias externally. In the first method, the valves are equipped with mechanical null bias adjustment located in the side of the valve body. In the second method, the valves have a feature in the torque motor cover that allows you to slightly alter the magnetic field above the torque motor, thereby changing the null bias.

### Mechanical Adjustment Procedure

With zero current (electrical connector disconnected). Using a 9.5 mm (3/8 in) offset wrench, loosen the self-locking fitting until the null adjustor pin can be rotated. (This should usually be less than  $\frac{1}{2}$  turn). DO NOT remove the self-locking fitting. Insert a 2.4 mm (3/32 in) Allen wrench in the null adjustor pin. Use the 2.4 mm (3/32 in) Allen wrench to rotate the mechanical adjustor pin to obtain the desired null flow. Re-torque the self locking fitting to 6.4 Nm (57 lbf in).

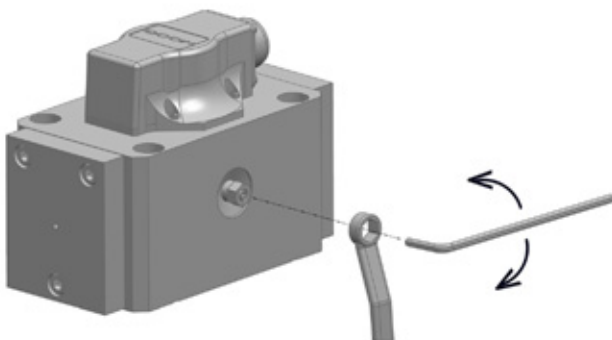

### Magnetic Adjustment procedure

The magnetic null adjustment allows at least  $\pm 10\%$  adjustment to the null flow. The magnetic null adjustor is located on top of the motor cap which if rotated magnetically biases the first stage torque motor. With zero current (electrical connector disconnected). Using a 22.2 mm (7/8 in) wrench, rotate the magnetic adjustor on top of the motor cap clockwise. If the flow is to the B-port and acceptable, the adjustor should not be rotated more than  $\pm 90$  degrees. If the flow is to the B-port and unacceptable, rotate the adjustor 180 degrees from the zero null bias which will result in null flow to the A-port with a clockwise rotation. Again, no more than  $\pm 90$  degrees.

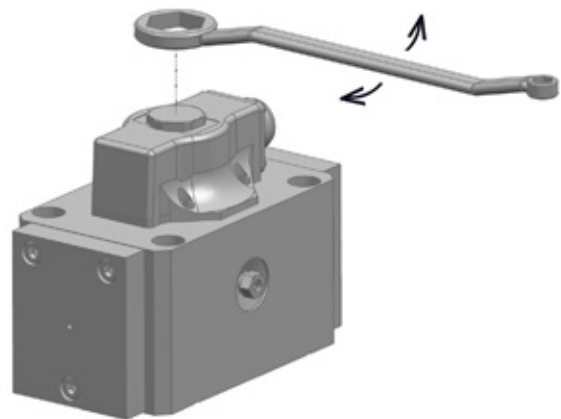

# FLOW CALCULATION

The actual flow is dependent upon electrical command signal and valve pressure drop. The flow for a given valve pressure drop can be calculated using the square root function for sharp edge orifices.

$$Q = Q_N \cdot \sqrt{\frac{\Delta p}{\Delta p_N}}$$

- Q [l/min (gpm)]      actual flow
- Q<sub>N</sub> [l/min (gpm)]      rated flow
- Δp [bar(psi)]      actual pressure drop per spool land
- Δp<sub>N</sub> [bar(psi)]      rated pressure drop per spool land

Flow diagram

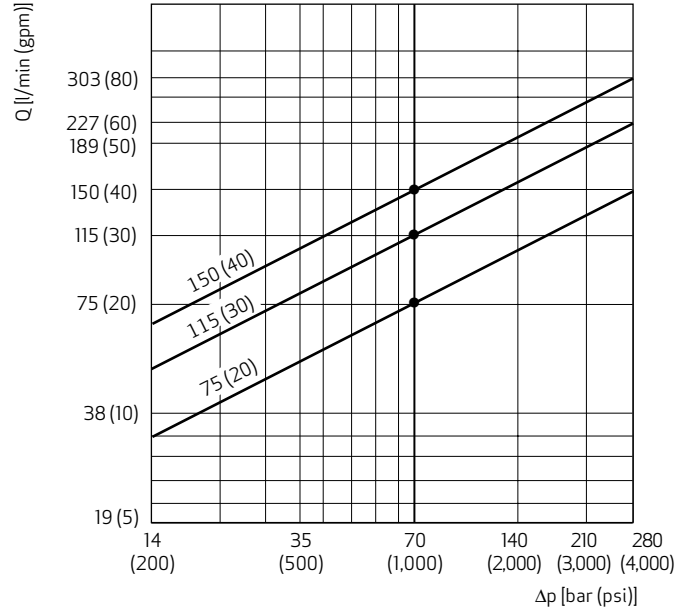

# NULL CUT OPTIONS

See Ordering Code for reference.

## Standard Axis Cut

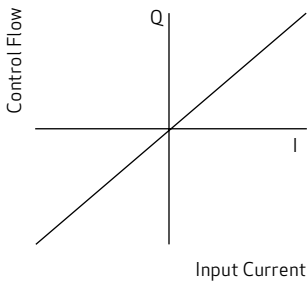

Default, without request for optional cuts

## Underlapped

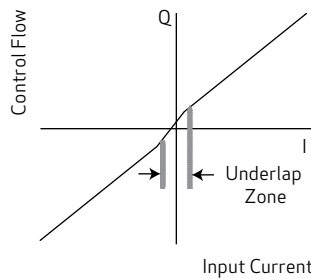

Normally used in hydraulic motor applications

## Overlapped

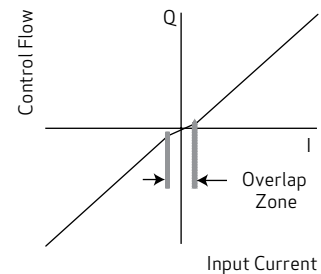

Normally used in failsafe considerations

## RELATED PRODUCTS

### DIN Rail Modules - Analog Control Cards

Moog's DIN rail mounted module analog control cards are ideal for use in enclosures where space is limited. Modules include servoamplifiers, transducer conditioning electronics, command and auxiliary function modules, valve drive amplifiers, and power supplies. All of these modules are CE marked and require a 24 V<sub>DC</sub> supply. The modules mount to standard 35 mm DIN rail mount for easy installation and removal.



DIN Rail Module

### Portable Valve Testers - Evaluates Valves in the Field

Valve testers are a cost effective method for evaluating valves in the field. They provide a quick and easy means of differentiating between hydraulic and electronic problems.

There are five models to choose from, each with different levels of capability and flexibility to meet your specific requirements. All valve testers have a compact, easily portable design.



Valve Tester

### Mounting Manifolds - Easier Installation and Maintenance

Various mounting manifolds are available for standard industrial valves, including base and adapter types for mounting and flushing requirements. Other hardware such as bolts and connectors are also available.

The specific accessories you may need for a particular model are listed in the relevant product catalogs and can be ordered through your local office.



Mounting Manifolds

### Filtration - Oil Filtration Requirements for Industrial Servo Systems

The most effective way to reduce life cycle costs of an oil hydraulic system is through close attention to contamination control.

For industrial servo systems the ideal system filter arrangement is summarized as follows:

- Use a 15 micron (Beta 15  $\geq$  75) high pressure filter without by-pass just before the valve or critical parts of the valve (e.g. pilot)
- Use a 3 micron (Beta 3  $\geq$  75) low pressure filter in the return or bypass line.
- Use a filter in the tank breather that is at least the same filtration level as the finest filter in the system.

This recommendation is based on the fact that most servo and proportional valves can accept the odd particle up to 25 microns so the pressure filter will protect the valve from catastrophic failure. The real work is done by the low pressure filter reducing small particle contamination which is the prime contributor to component wear and silting.



Hydraulic Filters

Assuming that the filters are properly dimensioned and care is taken during initial installation and maintenance, the aim should be to limit oil contamination to 16/13 (under the old ISO 4406) or 19/16/13 (under the new ISO 4406).

For long life, the maximum levels per the old and new ISO are 15/12 and 18/15/12, respectively. It is important to note that these are maximum contamination levels and with proper care and regular filter change, significantly lower levels can and should be achieved. Attention must also be paid to a number of other factors that contribute to oil condition problems such as elevated temperatures, high tank humidity, "dirty" new oil.



## ROUTINE MAINTENANCE GUIDELINES

Every six months or 4,000 operating hours, check for proper operation of the control valve assembly by performing the preventative maintenance steps outlined below. These checks do not require removal of the valve from the process line. If a problem is suspected, repair the valve assembly prior to returning the unit to service.

- Replace the hydraulic element
- Stroke the valve and check for smooth, full-stroke operation; unsteady motion could indicate a servo valve, actuator or process valve problem

### General Information

#### Effects when Storing Valves

The following effects may occur when storing valves for a long time:

- Sealing materials become brittle, possibly resulting in leaks
- Hydraulic fluid becomes gummy, possibly resulting in friction
- Electrolytic capacitors of the valve electronics may fatigue, possibly resulting in adverse effects on the valve electronics

#### Storage Time

The storage time starts at stock receipt and ends at mounting of the valve.

#### Preservatives

If conservation is carried out, use only conservatives which are compatible with the sealing materials and do not effect the valve, spare parts and accessories.

### Before Storage

#### Note:

If the valves are exposed to aggressive environmental influences during storage, vacuum packaging may be necessary.

We recommend the following preparatory measures for storage:

#### Mount the shipping plate on the valve.

This is the only way of adequately protecting the valves against the ingress of dirt and moisture and protecting the seals against the effects of ozone and UV

#### Put the valve, spare parts and accessories into the original packaging.

Package each valve separately

#### Enclose anti-tarnish paper or package the valve, spare parts and accessories with corrosion inhibiting film.

(Only for storage time > 1 year.)

Multipacks of single valves in their individual packages are allowed

#### Seal the original packaging properly.

This is the only way of adequately protecting the valves, spare parts and accessories against damage

### Storage Conditions

We recommend the following ambient conditions for storage:

#### Dust-free, moderately ventilated

#### As vibration-free and shock-free as possible

Shock resistance (as per EN 60068-2-27): 50 g, 6 directions, half-sine 3 ms

Vibration resistance (as per EN 60068-2-6): 30 g, 3 axes, frequency 10 to 2,000 Hz

#### Temperature

Recommended: +15 to +25 °C (+59 to +77 °F)

Permissible: -40 to +80 °C (-40 to +176 °F)

Temperature fluctuations >10 °C (50 °F) must be avoided!

**Distance to shielded radiators:** > 1 m (3 ft)

#### No direct exposure to sunlight

#### No sources of light with a high UV content

UV rays generate ozone, which damage sealing materials.

**Relative air humidity:** < 65 %, non condensing

### After Storage

>We recommend to check the original packaging, valve, spare parts and accessories for possible damage or alterations due to storage, that is, before use.

Damaged or not functional valves, spare parts and accessories must not be started up.

Sealing materials with the following characteristics must not be used:

- Contamination
- Cracking
- Hardening/softening
- Stickiness
- Discoloration

#### Storage Time > 5 Years

We recommend that the valve be checked by us or one of our authorized service centers after a storage time of more than 5 years.

#### Storage Time > 10 Years

After a storage time of more than 10 years the valves have to be checked by us or one of our authorized service centers.

## ABOUT MOOG

Moog Inc. is a worldwide designer, manufacturer and integrator of precision control components and systems. Moog's Industrial Group designs and manufactures high performance motion control solutions combining electric, hydraulic, and hybrid technologies with expert consultative support in a range of applications including energy production and generation machinery, industrial production machinery and simulation and test equipment. We help performance-driven companies design and develop their next-generation machines. Moog Industrial Group, with fiscal year 2011 sales of USD 629 million and over 40 locations worldwide, is part of Moog Inc. (NYSE:MOG.A and MOG.B) which has sales of USD 2.3 billion.

Moog maintains facilities in 26 countries around the globe. This vast scope ensures that our engineers remain close to the needs of machine builders and provide flexible design solutions and technical expertise tailored to our customers' toughest challenges.

Moog experts work in close collaboration with machine builders and application engineers to design motion control systems for greater productivity, higher reliability, superior connectivity, less costly maintenance and more effective operations. Our regional presence, industry knowledge and design flexibility ensures Moog motion control solutions are tailored to their environment—from meeting operating regulations and performance standards, to taking machine performance to a higher level.

## Products

At the heart of every Moog solution is an array of products engineered for precision, high performance and reliability. For more than six decades, Moog products have been specified for critical machine applications.

Some are developed specifically for unique operating environments. Others are standard equipment on machines across many industries. All are continuously improved to take advantage of the latest technology breakthroughs and advancements.

Moog products include:

- Servo Valves and Proportional Valves
- Servo Motors and Servo Drives
- Servo Controllers and Software
- Radial Piston Pumps
- Actuators
- Integrated Hydraulic Manifold Systems and Cartridge Valves
- Slip Rings
- Motion Bases



Servo Valves



Active Cartridge Valves



Radial Piston Pumps



Servo Drives

## ABOUT MOOG

### Solutions

#### Hydraulic solutions

Since Bill Moog invented the first commercially viable servo valve in 1951, Moog has set the standard for world-class hydraulic technology. Today, Moog products are used in a variety of applications - providing high power, enhanced productivity and ever better performance for some of the worlds most demanding applications.

#### Electric solutions

Clean operation, low noise generation, less maintenance and reduced power consumption make Moog electric solutions ideal for applications worldwide. Moog is the ideal partner for applications where transitioning technologies requires special expertise.

#### Hybrid solutions

By incorporating the advantages of existing hydraulic and electric technologies - including modular flexibility, increased efficiency and cleanliness - into innovative hybrid solutions, Moog offers new performance potential in specialized applications.

### Moog Global Support

Moog Global Support is our promise to offer world-class Repair and Maintenance Services delivered expertly by our trained technicians. With the reliability only available from a leading manufacturer with facilities around the world, Moog offers you service and expertise you can count on to keep your equipment operating as it should.

This promise offers many benefits to our customers including:

- Reduce your downtime by keeping critical machines running in peak performance
- Protect your investment by ensuring reliability, versatility and long-life of products
- Better plan your maintenance activities and make systematic upgrades
- Leverage our flexible programs to meet the unique service requirements of your facility

Look to Moog for global support including:

- Repair services using OEM parts are performed by trained technicians to the latest specifications
- Stock management of spare parts and products to prevent unplanned downtime



Flight Simulation



Formula One Simulation Table

- Flexible programs, tailored to your needs such as upgrades, preventative maintenance and annual/multi-year contracts
- On-site services bring the expertise to you, providing quicker commissioning, set-up and diagnostics
- Access to reliable services that are guaranteed to offer consistent quality anywhere in the world

For more information on Moog Global Support visit [www.moog.com/industrial/service](http://www.moog.com/industrial/service).



## ACCESSORIES AND SPARE PARTS

### Series Dependent Accessories and Spare Parts

#### Accessories 78 Series

Part designation	Description	Part number
Mating connector	4 pin electrical connector	-49054F014S02S
Mounting Manifold	Base mounting manifold	A31545AM001
Flushing plate	Manifold employed in place of valve when initially cleaning hydraulic fluids	A37333AM001
AMO manifold	Adjustable metering orifice manifold used to bleed fluid between A and B ports for better pressure control	A37425AM003
CRV manifold	Cross port relief manifold used to limit pressure levels in ports A and B	A37563AM001-xxxx
Safety manifold	Sandwich manifold used to lock, extend and retract cylinder upon loss of electrical signal or hydraulic pressure	B64470AMxxxxx
Mounting screws (Metric)	Quantity 4: M8 x 75 long; torque 12 to 15 Nm (106 to 133 lbf in)	B64929-008B075
Mounting screws (Inch)	Quantity 4: 0.312-18 x 3.0 long; torque 12 to 15 Nm (106 to 133 lbf in)	C66391-248B

#### Spare Parts 78 Series

Part designation	Description	Material	Part number
Base O-ring	Quantity 4: for P, T, A, and B ports 18.8 mm (0.739 in) inside diameter x 1.8 mm (0.070 in) cross section. Equivalent MIL-R- 83248 size -018	Fluorocarbon (FKM) 85 Shore D	-42082-021
Filter replacement kit	Quantity 2: O-ring 6 mm (0.239 in) inside diameter x 1.8 mm (0.070 in) cross section. Equivalent MIL-R- 83248 size -010  Quantity 2: O-ring 6.9 mm (0.270 in) inside diameter x 1.8 mm (0.070 in) cross section. Equivalent MIL-R- 83248 size -5-052  Quantity 2: O-ring 7.6 mm (0.301 in) inside diameter x 1.8 mm (0.070 in) cross section. Equivalent MIL-R- 83248 size -011  Quantity 1: filter tube 60 µm	Fluorocarbon (FKM) 85 Shore D	B52555RK052K001
Replaceable filter	Filter tube 60 µm		C39486-005-060

#### Documents (not included in scope of delivery)

Part designation	Description	Remark	Part number
Catalog	78 series general information	Note: Visit <a href="http://www.moog.com/industrial/literature">www.moog.com/industrial/literature</a> to download document	CDL6272
Service manual	78 standard series	Note: Visit <a href="http://www.moog.com/industrial/literature">www.moog.com/industrial/literature</a> to download document	CDS6569
Service manual	78 intrinsically safe (K) series	Note: Visit <a href="http://www.moog.com/industrial/literature">www.moog.com/industrial/literature</a> to download document	CDS6752
Service manual	78 explosion proof (N) series	Note: Visit <a href="http://www.moog.com/industrial/literature">www.moog.com/industrial/literature</a> to download document	CDS6857

# ORDERING CODE

Model number (assigned at the factory)

Type designation

78

- - - - - 1 2 3 4 5 6 7 8 9 10

Optional feature	
	Series specification
K	Intrinsically safe
N	Flameproof

Model designation

Variant

1 Valve version	
S	Standard response
H	High response

2 Rated flow in l/min (gpm)		
For $\Delta p_N = 70$ bar (1,000 psi) per spool land		
07	75	(20)
11	115	(30)
15	150	(40)

3 Maximum operating pressure in bar (psi)		
F	210	(3,000)

4 Bushing/spool design (see Null Cut Options for designation)	
O	4-way/axis cut/linear
D	4-way/ $\pm 10$ % overlap/linear
X	Special

10 Signals for 100 % spool stroke	
4	$\pm 4$ mA series ( $\pm 8$ mA parallel)
H	$\pm 7.5$ mA series ( $\pm 15$ mA parallel)
L	$\pm 20$ mA series ( $\pm 40$ mA parallel)
Z	$\pm 100$ mA series ( $\pm 200$ mA parallel)
Y	Special signal (on request)

9 Valve connector	
A	Connector over C1 (A) - side (RH)
B	Connector over C2 (B) - side (LH)
T	Connector over T
X	Special connector

8 Seal material	
V	Fluorocarbon (FKM) 85 Shore D
N	Nitrile/Buna N (NBR) 90 Shore D
	Others on request

7 Pilot connections and pressure		
4	Pressure in bar (psi)	Supply
	17 to 210 (250 to 3,000)	Internal

6 Spool position without electrical signal	
M	Mid position

5 Pilot stage design	
F	Standard dynamics
G	High dynamics

All combinations may not be available.

## Preferred Models

Model Number	Type Designation	Rated signal. single coil	Rated flow	Coil resistance	Maximum operating pressure
-078-121D	H07FOGM4VBL	$\pm 40$ mA	75 l/min (20 gpm)	80 $\Omega$	210 bar (3,000 psi)
-078-131D	H11FOGM4VBL	$\pm 40$ mA	115 l/min (30 gpm)	80 $\Omega$	210 bar (3,000 psi)
-078-136D	S15FOGM4VTL	$\pm 40$ mA	150 l/min (40 gpm)	80 $\Omega$	210 bar (3,000 psi)
-078-139D	S15FOGM4VBZ	$\pm 200$ mA	150 l/min (40 gpm)	22 $\Omega$	210 bar (3,000 psi)
-078-149D	S07FOFM4VBZ	$\pm 200$ mA	75 l/min (20 gpm)	22 $\Omega$	210 bar (3,000 psi)
-078-224D	S11FOGM4VBZ	$\pm 200$ mA	115 l/min (30 gpm)	22 $\Omega$	210 bar (3,000 psi)

# TAKE A CLOSER LOOK.

Moog designs a range of motion control products that complement the performance of those featured in this catalog. Visit our website for more information and contact the Moog facility nearest you.

Argentina  
+54 11 4326 5916  
info.argentina@moog.com

India  
+91 80 4057 6666  
info.india@moog.com

Singapore  
+65 677 36238  
info.singapore@moog.com

Australia  
+61 3 9561 6044  
info.australia@moog.com

Ireland  
+353 21 451 9000  
info.ireland@moog.com

South Africa  
+27 12 653 6768  
info.southafrica@moog.com

Brazil  
+55 11 3572 0400  
info.brazil@moog.com

Italy  
+39 0332 421 111  
info.italy@moog.com

Spain  
+34 902 133 240  
info.spain@moog.com

Canada  
+1 716 652 2000  
info.canada@moog.com

Japan  
+81 46 355 3767  
info.japan@moog.com

Sweden  
+46 31 680 060  
info.sweden@moog.com

China  
+86 21 2893 1600  
info.china@moog.com

Korea  
+82 31 764 6711  
info.korea@moog.com

Switzerland  
+41 71 394 5010  
info.switzerland@moog.com

Finland  
+358 10 422 1840  
info.finland@moog.com

Luxembourg  
+352 40 46 401  
info.luxembourg@moog.com

Turkey  
+90 216 663 6020  
info.turkey@moog.com

France  
+33 1 4560 7000  
info.france@moog.com

The Netherlands  
+31 252 462 000  
info.thenetherlands@moog.com

United Kingdom  
+44 168 429 6600  
info.uk@moog.com

Germany  
+49 7031 622 0  
info.germany@moog.com

Norway  
+47 6494 1948  
info.norway@moog.com

USA  
+1 716 652 2000  
info.usa@moog.com

Hong Kong  
+852 2 635 3200  
info.hongkong@moog.com

Russia  
+7 8 31 713 1811  
info.russia@moog.com

**[www.moog.com/industrial](http://www.moog.com/industrial)**

Moog is a registered trademark of Moog Inc. and its subsidiaries. All trademarks as indicated herein are the property of Moog Inc. and its subsidiaries.

CSA is a registered trademark of CSA International

DTE is a registered trademark of Exxon Mobil Corporation

©2012 Moog Inc. All rights reserved. All changes are reserved.

78 Series Flow Control Servo Valves  
PIM, Rev. M, March 2013, Id. CDL6272-en