

Service Data

# Vickers® Cylinders



[www.khadamathydraulic.com](http://www.khadamathydraulic.com)  
Tell: 021-55882749  
Tell: 021-33488178  
Fax: 021-33488105

## Series TV Hydraulic Cylinders

Installation & Service Manual



# Contents

---

Introduction .....	3
Cylinder Installation .....	4
Troubleshooting .....	5
Service .....	6
Exploded View .....	8
Maintenance .....	8
Seal Kits .....	10
Replacement Parts .....	12
How to Order .....	18
Model Code (Cylinder Identification) .....	19

# Introduction

## Purpose of manual

This manual has been prepared to assist users of Vickers Series TV cylinders for properly maintaining and repairing their units. In the sections that follow, instructions are given for proper installation, maintenance and overhaul.

## General information

Model codes have many variations within a basic model series. They are covered by variables in the model code. Service inquiries should always include the complete model code number as stamped on the head or cap and the three digit plant code.

## How to order

Vickers has developed an easy system for ordering Series TV Cylinders. This system has been developed to improve ease of ordering. The model code consists of sixteen alpha-numeric digits which fully describe the most common standard options offered.

To specify your Series TV cylinder, review the Model Code section for a full description of each option available and corresponding code.

## Custom cylinders

Although the model code has been arranged to cover the vast majority of available options, there will be occasions when an option which cannot be coded will be required. When such an option has been specified, enter an "X" for the appropriate item in the model code. For example, an application which requires a custom thread on the end of the piston rod, an "X" is inserted for item 7. The cylinder will include a unique five digit design number.

## Replacement cylinders

Every custom cylinder is assigned a unique design number. This number is contained in the last five digits of the sixteen digit model code. Item 12 is always an alpha character. The "Stroke" and "Extra Rod Projection" positions (items 12 through 16) become the "Design Number" items for custom cylinders. When ordering a replacement part or cylinder, give the sixteen digit model code or the five digit design number to your local Vickers Representative.

## Replacement parts

Each design number has a completed bill of materials on file in a quick retrieval computerized storage system. This gives the Field Sales Representatives rapid access in identifying and specifying genuine Vickers replacements parts.

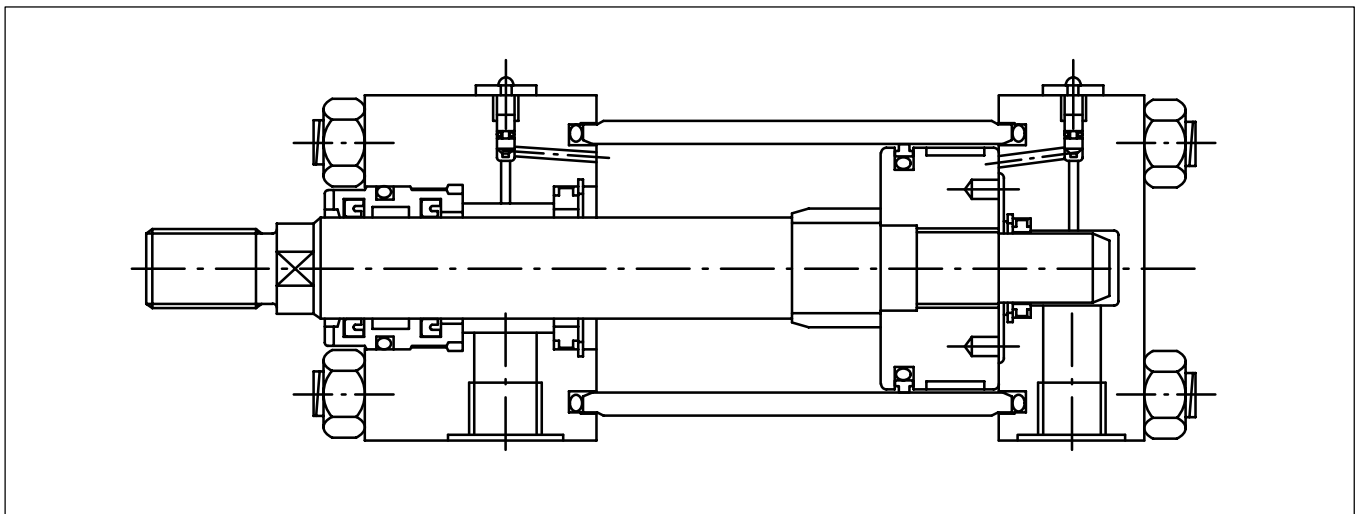

Figure 1. TV Cylinder Section View

# Cylinder Installation

---

All Vickers Series TV cylinders are individually tested and inspected before shipment to assure freedom from defects. Plugs are inserted in the ports to protect threads and keep foreign matter from entering the cylinder prior to installation.

## Mounting and alignment

Position the cylinder loosely in the mounting and check the alignment of the piston rod with the load connection at **both ends of the stroke**. If the cylinder is too large to move by hand, proceed with piping and installation and operate cylinder throughout the stroke prior to connection.

Trunnion and swivel mount bearings should fit closely for the entire length of the pin, and must be square with the load connection throughout the stroke.

Flush or foot mounted cylinders may be pinned or keyed to prevent shifting during high shock loads.

Always use the wrench flats when connecting piston rod to load to prevent damage to the sealing surface. Tighten piston rod against shoulder. If cylinder has been pressurized, relieve all pressure prior to turning the piston rod.

## Piping connections

All piping connections should be deburred and the system thoroughly flushed to purge all contaminants prior to connecting cylinder ports. Care should be taken to prevent over tightening of the piping connections.

## Cylinder operation

Cycle cylinder a few times with reduced load and pressure. Hydraulic cylinders may be erratic due to trapped air, but will normally purge themselves after several cycles. Some cylinders may be equipped with air bleed screws which can be slowly loosened with a male metric key wrench, then re-tightened after air is purged.

Cushioned cylinders are adjusted and tested prior to shipping, but usually require additional adjustment after connection to the work load. The cushion adjustment screw has a retainer plate to prevent inadvertent removal of the screw. A male metric hex wrench is required to adjust the cushion screw.

To increase effectiveness of the cushion, turn the adjustment screw clockwise. To provide less cushion, turn the screw counterclockwise. Most orifices are fully open with two full turns of the screw from the closed position.

The final position of the screw should be a balance between any shock or bounce at the start of the cushion and the final impact of the piston at the end of stroke.

# Troubleshooting

Most problems in fluid power circuits result in a gradual or sudden loss of power in the work cylinders, which may cause them to stall or move slower than required. This chart assumes that all other components of the circuit such as the pump, relief valve, control valves, hydraulic supply, etc. have been checked and the problem has been isolated to the cylinder.

Properly installed and maintained cylinders should function for millions of cycles. Premature cylinder failures are usually caused by system or application problems that can be prevented. The purpose of this chart is to aid in identifying and correcting the most common causes of premature cylinder malfunction.

<b>Check Cylinder for Evidence of:</b>	<b>Caused By:</b>	<b>Action Required:</b>
Excessive wear on piston rod.	Side load due to misalignment between cylinder and load.	Check alignment of rod with load connection at all points in stroke.
	Pivot mount cylinder without proper stop tubing.	Follow Vickers cylinder catalog design recommendations.
Contamination in cylinder.	Exceptionally dirty environment.	Clean and flush the entire system, deburr connections.
	Worn rod wiper.	Shield piston rod area from direct contact with contaminant.
Impact damage or broken parts.	Lack of, or improperly adjusted cushions.	Reference adjustment instructions in this manual.
	Load and piston speed combination exceeds cylinder cushion capacity.	Consult your Vickers Sales Engineer.
	Lack of, or improperly adjusted speed controls.	Add or adjust flow controls to reduce piston speed.
	Excessive system pressure.	Reduce pressure to minimum required to move the load.
Permanent deformation or damaged static seals.	System pressure in excess of cylinder rating.	Follow Vickers cylinder catalog design recommendations.
	High pressure developed in cylinder cushion.	Consult your Vickers Sales Engineer.
	Cylinder externally loaded while control valve is closed.	Reduce load magnitude or resize cylinder.
Seal damage such as loss of elasticity, shape, etc.	Excessive temperature in environment or system.	Install replacement sealing system with proper rating.
	Incompatible hydraulic fluid.	Refer to Vickers cylinder catalog for compatible sealing system.
	Cylinder stored in horizontal position for extended period.	Replace seals, store vertically with rod up.

Table 1.

# Service

The following instructions illustrate the complete rebuilding of your Vickers Series TV hydraulic cylinder.

Refer to Figure 4 exploded view.



## CAUTION

Before breaking a circuit connection, make certain that power is OFF and system pressure has been released. Lower all vertical cylinders, discharge accumulators, and block any load whose movement could generate pressure. Plug all removed units and cap all lines to prevent the entry of dirt into the system.

### Required tools

- Spanner wrench
- Adjustable wrench
- Soft brass tool
- Thin tool
- Copper padded vice
- Rubber mallet
- Torque wrench

### Replacing rod seals

1. Once the cylinder is removed from service, fully retract the piston rod and remove all port connections. Drain any hydraulic fluid by manually cycling the cylinder. Large cylinders can be carefully cycled with air pressure.
2. The Quick Change rod cartridge allows rod seal replacement without disturbing the tie rods. Remove any burrs from the wrench flat area of the piston rod. Place the cylinder in a vice, rod end up if possible. Remove the rod cartridge by rotating it counterclockwise with a spanner wrench. (If an appropriate spanner wrench is not available, service is best performed by disassembling the entire cylinder. The cartridge can then be removed by placing a bar such as a square shanked screw driver in the cartridge slots, after removing the rod from the head.)
3. Remove the rod seal from the cartridge by carefully prying it out of the groove with a dull brass (or other soft material tool.)

4. Remove the elastomer wiper from the outer most groove by carefully prying it out of the groove with the dull brass tool.
5. The non-metallic wear band can be removed from the cartridge in a similar fashion.
6. Lightly lubricate the new rod seal, o-rings, wear band and wiper. Install them in the cartridge as shown in Figure 2. Carefully lead the outside sealing edge into each groove. Be careful not to damage the seal or wiper.

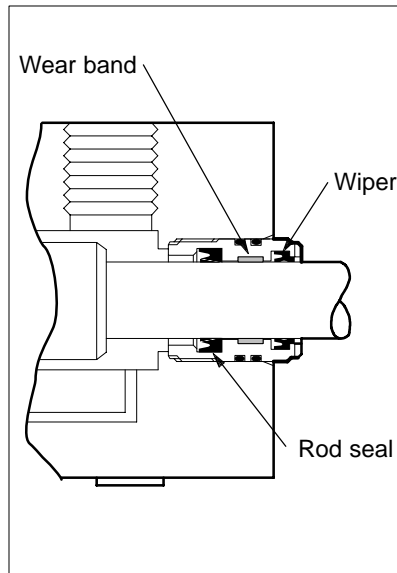

Figure 2.

7. Carefully replace the cartridge on the rod so that seal or wiper lips are not damaged when placing them over the piston rod. Threaded cartridges should be turned clockwise and tightened with a spanner wrench.
8. The bolt cartridges on larger rods of units produced prior to 1996 use a retainer plate. Slide the retainer plate into position. Replace the retainer screws, and tighten in a cross sequence pattern. Torque to the values shown in Table 2.

Bore (mm)	Rod (mm)	Torque	
		(ft. lb.)	(Nm)
125	90	34	45

160	110	26	35
200	140	52	70

Table 2.

### Complete rebuild

1. Repeat steps 1, 2, 3, 4 and 5 in **Replacing rod seals** section.
2. Remove the tie rod nuts, loosening in a cross sequence pattern. Carefully remove the cap or head from the tie rods and inspect for damage or signs of contamination.
3. Remove the cylinder body from the head/cap. Slide the piston rod assembly out of the cylinder body. It is not normally necessary to remove the tie rods if threaded into a tapped head or cap for servicing, unless the tapped head or cap is mechanically damaged.
4. The piston does not have to be removed from the rod for normal piston seal replacement. The piston seal can be removed by inserting a thin tool under the seal and running it around the circumference of the piston. The elastomer energizer under the face seal should also be removed.
5. Remove the nonmetallic wear band which simply snaps into the groove on the piston's outer diameter.
6. If piston removal is required, clamp the piston rod securely in a copper padded vice to protect the rod finish.

- Heat the piston to approximately 175°C with a torch or oven to break the anaerobic adhesive. Insert a spanner wrench in the drilled holes on the piston face and break the seal by rapping the wrench with a rubber mallet, rotating the piston in a counterclockwise direction.

On small cylinders, an alternate method not requiring a spanner wrench is to clamp the piston in a soft jawed vice and turn the rod, using an adjustable wrench on the rod flats.



**CAUTION**

**THE PISTON IS HOT!**

- Unscrew the piston and set it aside.
- Remove the cushion collar from the rod, if the cylinder is cushioned on the head end. Let the rod cool before re-assembly.
- Snugly secure the rod into the vice. Replace the cushion collar on the rod (if required). Thoroughly clean all metallic surfaces with a non-petroleum based cleaner and a wire brush, if necessary.
- Apply anaerobic adhesive near the rod shoulder (or collar) on the rod threads and on the piston I.D. threads.

**NOTE**

Be sure to follow the adhesive manufacturer's recommendations regarding surface preparation, priming requirements, proper adhesive for the thread size, and cure time prior to pressurization. Failure to do so could result in improper sealing and retention.

- Tighten the piston on the rod to the torque listed in Table 3, using the spanner wrench holes provided in the piston.
- Install new seals by placing one side in the piston groove and stretching the seal around the piston circumference with the thin tool used in disassembly. The elastomer

energizer should be installed in the bottom of the groove before installing the plastic face seal, as shown in Figure 3.

Rod Ø (mm)	Piston Torque	
	(ft. lb.)	(Nm)
12	15	20
14	20	27
18	30	40
22	30	40
28	40	54
36	40	54
45	50	67
56	100	135
70	135	180
90	250	340
110	400	540
140	550	740

Table 3.

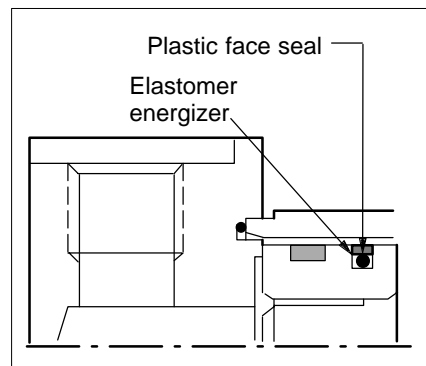

Figure 3.

- Cylinder body O-rings are easily removed using a thin blade tool. Care should be taken to avoid damaging the surface finish in the groove with the tool.
- Metallic cushion sleeves can be replaced by removing the snap ring sleeve retainers.

Note the sleeve orientation in the groove before removal. Some sleeves are not symmetrical and new sleeves must be installed in the groove in the same orientation.

- Shorter cylinders are more easily assembled in a vertical position. Insert the body O-ring in the cap body groove and position the cylinder body on the cap.
- Snap the wear band on the piston into the wide groove. Lubricate the piston O.D. and seals. Carefully insert the piston rod assembly into the cylinder body. The body is designed to easily accept the piston with the sealing system in place.
- Install the body O-ring in the head body groove. When properly installed, the O-ring should remain in the head when inverted. Grease will hold the o-ring in place if required. Place the cylinder head with tie rods on the body.
- Repeat steps 6, 7 and 8 in "Replacing rod seals" section.
- Start the tie rod nuts until snug against the head or cap and lay the cylinder on its side. Secure the cylinder horizontally into a vice or clamped to a flat surface.
- Tighten the tie rod nuts gradually in a cross sequence pattern to equally distribute forces around the cylinder with a torque wrench. The required torque values are listed in Table 4. Check each nut a second time after reaching full torque.

Rod Ø (mm)	Tie Rod Torque*	
	(ft. lb.)	(Nm)
25	4	5,5
32	7	11
40	14	19
50	33	45
63	50	68
80	105	140
100	150	205
125	340	460
160	690	935
200	1120	1520

Table 4.

\*Recommended torque values using MoS<sub>2</sub> lubricant with 0.12 coefficient of friction.

# Exploded view

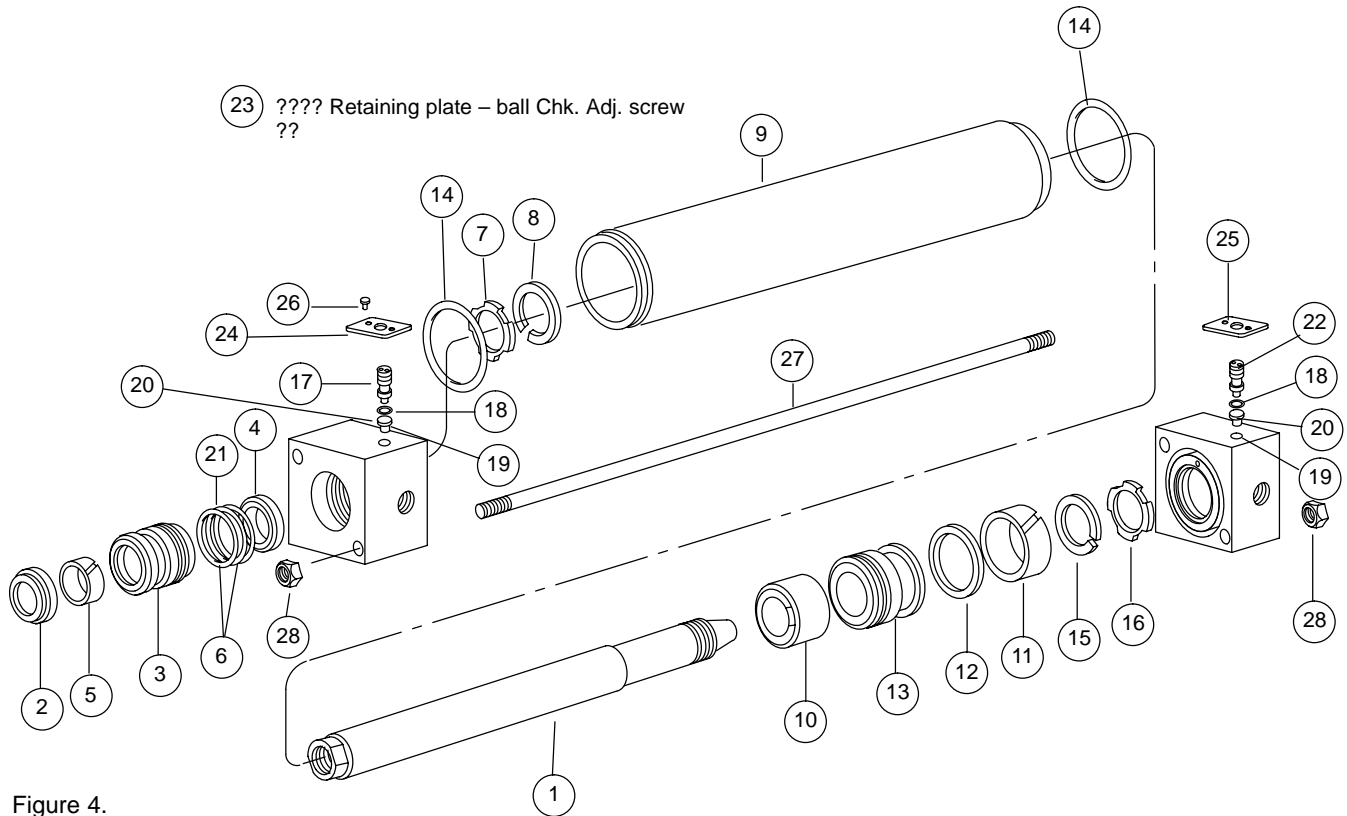

Figure 4.

## Maintenance

### Inspection

All parts in the unit must be kept clean during the overhaul. Handle each part with care and always work in a clean area.

Periodic inspection of the fluid condition and tube or piping connections can save time consuming breakdowns and unnecessary parts replacement. The following should be checked regularly:

1. All hydraulic connections must be kept tight. A loose connection in a pressure line will permit the fluid to leak out. If the fluid level becomes so low as to uncover the inlet pipe opening in the reservoir, extensive damage to the pump can result. In suction or return lines, loose connections permit air to be drawn into the system resulting in noisy and/or erratic operation.
2. Clean fluid is the best insurance for long service life. Therefore, the reservoir should be checked periodically for dirt or other contaminants. If the fluid becomes contaminated, the system should be drained and the reservoir cleaned before new fluid is added.
3. Filter elements also should be checked and replaced periodically. A clogged filter element results in a higher pressure drop. This can force particles through the filter which would ordinarily be trapped, or can cause the by-pass to open, resulting in a partial or complete loss of filtration.
4. Air bubbles in the reservoir can ruin the pump and other components. If bubbles are seen, locate the source of the air and seal the leak.



---

## Cleanliness

Thorough precautions should always be observed to insure the hydraulic system is clean:

1. Clean (flush) entire new system to remove paint, metal chips, welding shot, etc.
2. Filter each change of oil to prevent introduction of contaminants into the system.
3. Provide continuous oil filtration to remove sludge and products of wear and corrosion generated during the life of the system.
4. Provide continuous protection of system from entry of airborne contamination by sealing the system and/or by proper filtration of the air.
5. During usage, proper oil filling and servicing of filter, breathers, reservoirs, etc., cannot be over emphasized.
6. Thorough precautions should be taken by proper system and reservoir design, to insure that aeration of the oil will be kept to a minimum.

Vickers supports and recommends the hydraulic Systems Standards for Stationary Industrial Machinery advanced by the American National Standards Institute; ANSI/(NFPA/JIC) T2.24.1-1991. Key elements of this Standard as well as other vital information on the correct methods for treating hydraulic fluid are included in Vickers publication #561; "Vickers Guide to Systemic Contamination Control," available from your local Vickers distributor or by contacting Vickers. Recommendations on filtration and the selection of products to control fluid condition are included in this publication.

## Sound Level

Noise is only indirectly affected by the fluid selection, but the condition of the fluid is of paramount importance in obtaining optimum reduction of system sound levels.

Some of the major factors affecting the fluid conditions that cause the loudest noises in a hydraulic system are:

1. Very high viscosities at start-up temperature can cause pump noises due to cavitation.
2. Running with a moderately high viscosity fluid will slow the release of air captured in the fluid. The fluid will not be completely purged of such air in the time it remains in the reservoir before recycling through the system.
3. Aerated fluid can be caused by ingestion of air through the pipe joints of inlet lines, high velocity discharge lines, cylinder rod packings or by fluid discharging above the fluid level in the reservoir. Air in the fluid causes a noise similar to cavitation.

## Hydraulic Fluid Recommendations

Oil in a hydraulic system performs the dual function of lubrication and transmission of power. It constitutes a vital factor in a hydraulic system, and careful selection of it should be made with the assistance of a reputable supplier. Proper selection of oil assures satisfactory life and operation of system components with particular emphasis on hydraulic pumps. Any oil selected for use with pumps is acceptable for use with valves, cylinders or motors.

Order literature #694 for oil selection recommendations.

## Adding Fluid to the System

When hydraulic fluid is added to the system, it should be pumped through a 10 micron absolute filter. The use of a Vickers Clean Cart portable filtering transfer unit to filter clean fluid into the system is recommended. For further information on the Clean Cart transfer unit, obtain service drawing #601.

It is important that the fluid be kept clean and free from any substance that may cause improper operation or wear to the cylinder, pump and other hydraulic units. Therefore, the use of cloth to strain the fluid should be avoided to prevent lint from entering the system.

## Replacement Parts

Reliable operation throughout the specified operating range is assured only if genuine Vickers parts are used. Sophisticated design processes and materials are used in the manufacture of our parts. Substitutes may result in early failure.

## Product Life

The service life of these products is dependent on environment, duty cycle, operating parameters and system cleanliness. Since these parameters vary from application to application, the ultimate user must determine and establish the periodic maintenance required to maximize life and detect potential component problems.

## Fluids

Proper fluid condition is essential for long and satisfactory life of hydraulic components and systems. Hydraulic fluid must have the correct balance of cleanliness, materials and additives for protection against wear of components, elevated viscosity and inclusion of air.

Essential information on the correct methods for treating hydraulic fluid is included in Vickers publication 561; "Vickers Guide to Systemic Contamination Control," available from your local Vickers distributor or by contacting Vickers, Incorporated.

Recommendation of filtration and the selection of products to control fluid condition are included in #561.

Recommended cleanliness levels using petroleum oil under common conditions is based on the highest fluid pressure levels in the system.

Fluids other than petroleum, severe service cycles or temperature extremes are cause for adjustment of these cleanliness codes. See Vickers Publication #561 for exact details.

## System Pressure Level

Product	70 bar	140 bar	210+ bar
Cylinders	20/18/15	20/18/15	20/18/15

# Seal Kits

Bore Size	Rod Diameter	Rod Cartridge Seals Kits (1)			Piston Seal Kits (2)		
		"N" Normal	"L" Low Friction	"T" High Temperature	"N" Normal	"L" Low Friction	"T" High Temperature
		Seal Kit No.	Seal Kit No.	Seal Kit No.	Seal Kit No.	Seal Kit No.	Seal Kit No.
25	12	6533N-TVBB	6533L-TVBB	6543T-TVBB	6633N-TVBB	6633L-TVBB	6643T-TVBB
	18	6533N-TVCE	6533L-TVCE	6543T-TVCE	6633N-TVBB	6633L-TVBB	6643T-TVBB
32	14	6533N-TV2C	6533L-TV2C	6543T-TV2C	6633N-TV2C	6633L-TV2C	6643T-TV2C
	22	6533N-TVDG	6533L-TVDG	6543T-TVDG	6633N-TV2C	6633L-TV2C	6643T-TV2C
40	18	6533N-TVCE	6533L-TVCE	6543T-TVCE	6633N-TVCE	6633L-TVCE	6643T-TVCE
	22	6533N-TVDG	6533L-TVDG	6543T-TVDG			
	28	6533N-TVEJ	6533L-TVEJ	6543T-TVEJ			
50	22	6533N-TVDG	6533L-TVDG	6543T-TVDG	6633N-TVDG	6633L-TVDG	6643T-TVDG
	28	6533N-TVEJ	6533L-TVEJ	6543T-TVEJ			
	36	6533N-TVGL	6533L-TVGL	6543T-TVGL			
63	28	6533N-TVEJ	6533L-TVEJ	6543T-TVEJ	6633N-TVEJ	6633L-TVEJ	6643T-TVEJ
	36	6533N-TVGL	6533L-TVGL	6543T-TVGL			
	45	6533N-TVHN	6533L-TVHN	6543T-TVHN			
80	36	6533N-TVGL	6533L-TVGL	6543T-TVGL	6633N-TVGL	6633L-TVGL	6643T-TVGL
	45	6533N-TVHN	6533L-TVHN	6543T-TVHN			
	56	6533N-TVKQ	6533L-TVKQ	6543T-TVKQ			
100	45	6533N-TVHN	6533L-TVHN	6543T-TVHN	6633N-TVHN	6633L-TVHN	6643T-TVHN
	56	6533N-TVKQ	6533L-TVKQ	6543T-TVKQ			
	70	6533N-TVLS	6533L-TVLS	6543T-TVLS			
125	56	6533N-TVKQ	6533L-TVKQ	6543T-TVKQ	6633N-TVKQ	6633L-TVKQ	6643T-TVKQ
	70	6533N-TVLS	6533L-TVLS	6543T-TVLS			
	90	6533N-TVNU	6533L-TVNU	6543T-TVNU			
160	70	6533N-TVLS	6533L-TVLS	6543T-TVLS	6633N-TVLS	6633L-TVLS	6643T-TVLS
	90	6533N-TVNU	6533L-TVNU	6543T-TVNU			
	110	6533N-TVLW	6533L-TVLW	6543T-TVLW			
200	90	6533N-TVNU	6533L-TVNU	6543T-TVNU	6633N-TVNU	6633L-TVNU	6643T-TVNU
	110	6533N-TVLW	6533L-TVLW	6543T-TVLW			
	140	6533N-TVNZ	6533L-TVNZ	6543T-TVNZ			

(1) Rod Cartridge Seal Kits Include:

- 1 Rod wiper
- 1 Rod seal
- 1 Rod Wear band
- 2 O.D. Bearing seal
- 1 Back-up ring (when req'd)

(2) Piston Seal Kits Include:

- 2 Body O-rings
- 1 Piston wear band
- 1 Piston seal

# Exploded view

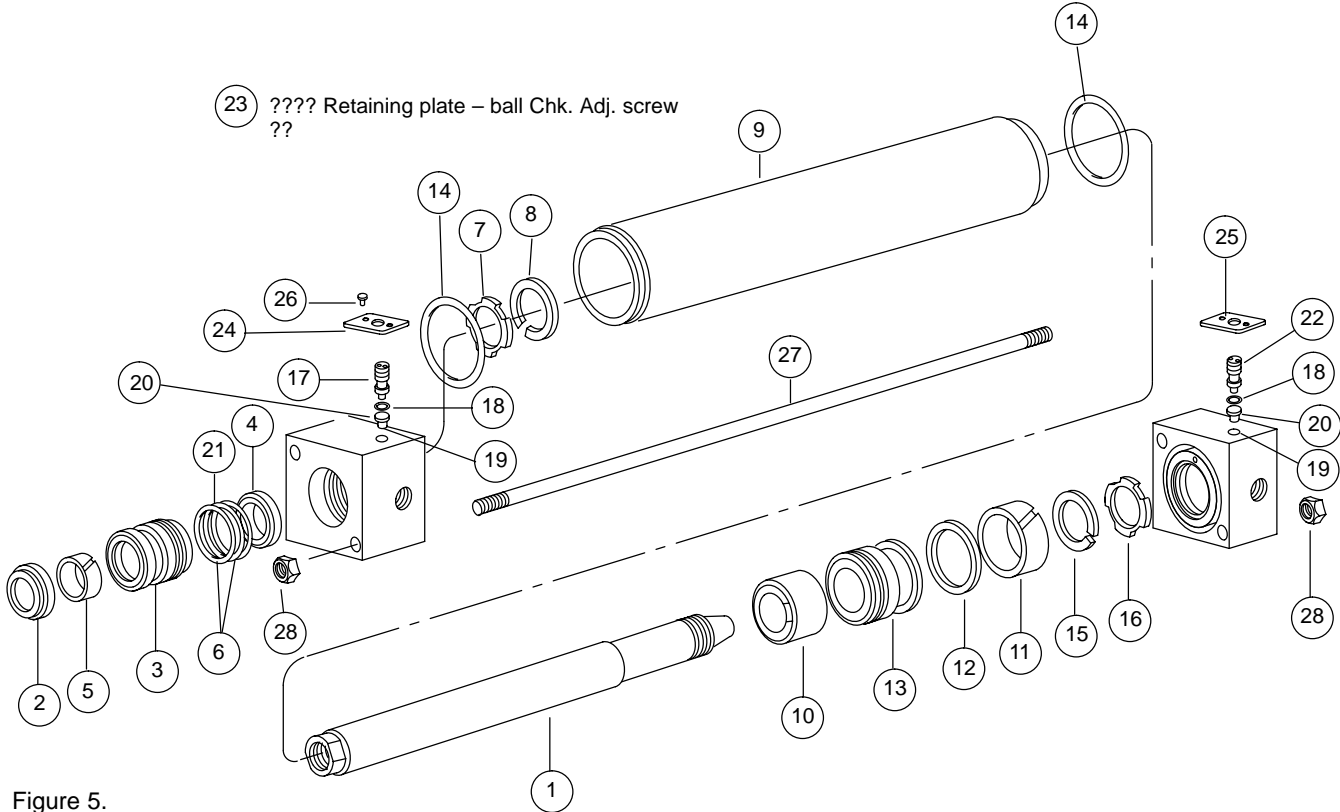

Figure 5.

# Replacement Parts - Single Rod Cylinders

Refer to Figure 5.

Key No.	Part Name	No Req'd	BORE SIZE 25	BORE SIZE 25	BORE SIZE 32	BORE SIZE 32
			ROD 12	ROD 18	ROD 14	ROD 22
**1	Piston rod (# = rod end type) Non-cushioned Cushioned head end Cushioned cap end Cushioned both ends Specify stroke	1	TV82B□BA10B__	TV82E□BA10B__	TV82C□2A10B__	TV82G□2A10B__
		1	TV82B□BF10B__	TV82E□BF10B__	TV82C□2F10B__	TV82G□2F10B__
		1	TV82B□BC10B__	TV82E□BC10B__	TV82C□2C10B__	TV82G□2C10B__
		1	TV82B□BL10B__	TV82E□BL10B__	TV82C□2L10B__	TV82G□2L10B__
*2	Rod wiper (Normal sealing system option)	1	7946-012	7946-018	7946-014	7946-022
3	Rod bearing- Place appropriate code into □ in part no. A = Normal sealing; B = Low friction/high temp.	1	TV81B□000	TV81E□000	TV81C□000	TV81G□000
*4	Rod seal (Normal sealing system option)	1	7942-012	7942-018	7942-014	7942-022
*5	Rod wear band	1	8126-012	8126-018	8126-014	8126-022
*6	Seal O.D. bearing	2	5145-019-A	5145-023-A	5145-023-A	5145-026-A
7	Cushion sleeve (Head end) (Rod end cushion cylinders only)	1	N/A	N/A	N/A	N/A
8	Retainer ring (Head end) (Rod end cushion cylinders only)	1	N/A	N/A	N/A	N/A
9	Body (Consult factory if intermediate trunnion mount) Specify stroke	1	TV57BA _____	TV57BA _____	TV572A _____	TV572A _____
10	Cushion collar	1	TV93BB1C	TV93EB1C	TV93C21C	TV93G21C
*11	Piston wear band	1	7949-025	7949-025	7949-032	7949-032
*12	Piston seal (Normal sealing system option)	1	7948-025	7948-025	7948-032	7948-032
13	Piston	1	TV53BF0B7	TV53BF0E7	TV532F0C7	TV532F0G7
*14	Body O-ring (Normal sealing system option)	2	5145-023-A	5145-023-A	5145-027-A	5145-027-A
15	Retainer ring (Cap end) (Cap cushioned cylinders only)	1	N/A	N/A	N/A	N/A
16	Cushion sleeve (Cap end) (Cap cushioned cylinders only)	1	N/A	N/A	N/A	N/A
17	Cushion adjusting screw (2 req'd if cushioned both ends)	1 or 2	TV95-025	TV95-025A	TV95-025	TV95-025A
18	Cushion adjusting O-ring (2 req'd if cushioned both ends)	1 or 2	5145-003-A	5145-003-A	5145-003-A	5145-003-A
19	Steel ball (1 req'd if cushioned head end)	1	02-152533	02-152533	02-152533	02-152533
20 ***	Ball retainer (1 req'd if cushioned head end)	1 or 2	TV98-025	TV98-025	TV98-025	TV98-025
*21	Back-up ring	1	N/A	N/A	N/A	N/A
22 ***	Air bleeder screw	A/R	TV94-025	TV94-025	TV94-025	TV94-025
23	Retaining plate – Ball check adj. screw	1 per screw	7971-025	7971-025	7971-025	7971-025
24	Retaining plate – Cushion adj. screw	1 per screw	7972-025	7972-025	7972-025	7972-025
25	Retaining plate – Air bleed adj. screw	1 per screw	7973-025	7973-025	7973-025	7973-025
26	Retaining plate drive screws (Included with retaining plate)	A/R				
27	Tie rods (Specify mtg. style/bore & stroke)	4	TV56 _ A _____	TV56 _ A _____	TV56 _ B _____	TV56 _ B _____
28	Tie rod nuts (Specify mtg. style/bore & stroke)	A/R	5305-003	5305-003	5305-004	5305-004

Notes:

\* Sold in seal kit only

\*\* A four character suffix will appear at the end.

\*\*\* Order item #18 for O-rings req'd

# Replacement Parts

Refer to Figure 5.

Key No.	No Req'd	BORE SIZE 40	BORE SIZE 40	BORE SIZE 40	BORE SIZE 50	BORE SIZE 50	BORE SIZE 50
		ROD 18	ROD 22	ROD 28	ROD 22	ROD 28	ROD 36
**1	1 1 1 1	TV82E□CA10B— TV82E□CF10B— TV82E□CC10B— TV82E□CL10B—	TV82G□CA10B— TV82G□CF10B— TV82G□CC10B— TZ82G□CL10B—	TV82J□CA10B— TV82J□CF10B— TV82J□CC10B— TV82J□CL10B—	TV82G□DA10B— TV82G□DF10B— TV82G□DC10B— TV82G□DL10B—	TV82J□DA10B— TV82J□DF10B— TV82J□DC10B— TV82J□DL10B—	TV82L□DA10B— TV82L□DF10B— TV82L□DC10B— TV82L□DL10B—
*2	1	7946-018	7946-022	7946-028	7946-022	7946-028	7946-033
3	1	TV81E□000	TV81G□000	TV81J□000	TV81G□000	TV81J□000	TV81L□000
*4	1	7942-018	7942-022	7942-028	7942-022	7942-028	7942-036
*5	1	8126-018	8126-022	8126-028	8126-022	8126-028	7944-036
*6	2	5145-023-A	5145-026-A	5145-029-A	5145-026-A	5145-029-A	5145-133-A
7	1	SH-92-R-15	N/A	N/A	N/A	N/A	N/A
8	1	5194-118-HD	N/A	N/A	N/A	N/A	N/A
9	1	TV57CA_____	TV57CA_____	TV57CA_____	TV57DA_____	TV57DA_____	TV57DA_____
10	1	TV93EC1C	TV93GC1C	TV93JC1C	TV93GD1C	TV93JD1C	TV93LD1C
*11	1	7949-040	7949-040	7949-040	7949-050	7949-050	7949-050
*12	1	7948-040	7948-040	7948-040	7948-050	7948-050	7948-050
13	1	TV53CF0E7	TV53CF0G7	TV53CF0J7	TV53DF0G7	TV53DF0J7	TV53DF0L7
*14	2	5145-030-A	5145-030-A	5145-030-A	5145-034-A	5145-034-A	5145-034-A
15	1	5194-75-DG	5194-75-DG	5194-75-DG	5194-100-DG-R	5194-100-DG-R	5194-100-DG-R
16	1	SH-92-B-15	SH-92-B-15	SH-92-B-15	TV920135A	SH-92-B-20	SH-92-B-20
17	1 or 2	TV95-040	TV95-040	TV95-040	TV95-040	TV95-040	TV95-040
18	1 or 2	5145-005-A	5145-005-A	5145-005-A	5145-005-A	5145-005-A	5145-005-A
19	1	N/A	02-157952	02-157952	02-157952	02-157952	02-157952
20 ***	1	N/A	TV98-040	TV98-040	TV98-040	TV98-040	TV98-040
*21	1	N/A	N/A	N/A	N/A	N/A	N/A
22 ***	A/R	TV94-040	TV94-040	TV94-040	TV94-040	TV94-040	TV94-040
23	1 per screw	7971-040	7971-040	7971-040	7971-040	7971-040	7971-040
24	1 per screw	7972-040	7972-040	7972-040	7972-040	7972-040	7972-040
25	1 per screw	7973-040	7973-040	7973-040	7973-040	7973-040	7973-040
26	A/R						
27	4	TV56 _ C_____	TV56 _ C_____	TV56 _ C_____	TV56 _ E_____	TV56 _ E_____	TV56 _ E_____
28	A/R	5305-006	5305-006	5305-006	5305-010	5305-010	5305-010

**Notes:**

- \* Sold in seal kit only
- \*\* A four character suffix will appear at the end.
- \*\*\* Order item #18 for O-rings req'd.

Refer to Figure 5.

Key No.	Part Name	No Req'd	BORE SIZE 63	BORE SIZE 63	BORE SIZE 63	BORE SIZE 80
			ROD 28	ROD 36	ROD 45	ROD 36
**1	Piston rod Non-cushioned (# = rod end type) Cushioned head end Cushioned cap end Specify stroke Cushioned both ends	1 1 1 1	TV82J□EA10B___ TV82J□EF10B___ TV82J□EC10B___ TV82J□EL10B___	TV82L□EA10B___ TV82L□EF10B___ TV82L□EC10B___ TV82L□EL10B___	TV82N□EA10B___ TV82N□EF10B___ TV82N□EC10B___ TV82N□EL10B___	TV82L□GA10B___ TV82L□GF10B___ TV82L□GC10B___ TV82L□GL10B___
*2	Rod wiper (Normal sealing system option)	1	7946-028	7946-036	7946-045	7946-036
3	Rod bearing- Place appropriate code into # in part no. A = Normal sealing; B = Low friction/high temp.	1	TV81J□000	TV81L□000	TV81N□000	TV81L□000
*4	Rod seal (Normal sealing system option)	1	7942-028	7942-036	7942-045	7942-036
*5	Rod wear band	1	8126-018	7944-036	7944-045	7944-036
*6	Seal O.D. bearing (2 req'd w/gland drain)	1	5145-029-A	5145-133-A	5145-141-A	5145-133-A
7	Cushion sleeve (Head end) (Rod end cushion cylinders only)	1	SH-92-R-25	N/A	N/A	SH-92-R-32
8	Retainer ring (Head end) (Rod end cushion cylinders only)	1	5194-200-HD-R	N/A	N/A	5194-250-DG-R
9	Body (Consult factory if intermediate trunnion mount) Specify stroke	1	TV57EA _____	TV57EA _____	TV57EA _____	TV57GA _____
10	Cushion collar	1	TV93JE1C	TV93LE1C	TV93NE1C	TV93LG1C
*11	Piston wear band	1	7949-063	7949-063	7949-063	7949-080
*12	Piston seal (Normal sealing system option)	1	7948-063	7948-063	7948-063	7948-080
13	Piston	1	TV53EF0J7	TV53EF0L7	TV53EF0N7	TV53GF0L7
*14	Body O-ring (Normal sealing system option)	2	5145-145-A	5145-145-A	5145-145-A	5145-152-A
15	Retainer ring (Cap end) (Cap cushioned cylinders only)	1	5194-100-DG-R	5194-100-DG-R	5194-100-DG-R	5194-100-DG
16	Cushion sleeve (Cap end) (Cap cushioned cylinders only)	1	SH-92-B-25	SH-92-B-25	SH-92-B-25	SH-92-B-32
17	Cushion adjusting screw (2 req'd if cushioned both ends)	1 or 2	TV95-040	TV95-040	TV95-040	TV95-080
18	Cushion adjusting O-ring (2 req'd if cushioned both ends)	1 or 2	5145-005-A	5145-005-A	5145-005-A	5335-020-A
19	Steel ball (1 req'd if cushioned head end)	1 or 2	N/A	02-157952	02-157952	N/A
20 ***	Ball retainer (1 req'd if cushioned head end)	1 or 2	N/A	TV98-040	TV98-040	N/A
*21	Back-up ring	1	N/A	N/A	N/A	N/A
22 ***	Air bleeder screw	A/R	TV94-040	TV94-040	TV94-040	TV94-080
23	Retaining plate – Ball check adj. screw	1 per screw	7971-040	7971-040	7971-040	7971-080
24	Retaining plate – Cushion adj. screw	1 per screw	7972-040	7972-040	7972-040	7972-080
25	Retaining plate – Air bleed adj. screw	1 per screw	7973-040	7973-040	7973-040	7973-080
26	Retaining plate drive screws (Included with retaining plate)	A/R				
27	Tie rods (Specify mtg. style/bore & stroke)	4	TV56 _ E _____	TV56 _ E _____	TV56 _ E _____	TV56 _ F _____
28	Tie rod nuts (Specify mtg. style/bore & stroke)	A/R	5305-010	5305-010	5305-010	5305-014

Notes:

\* Sold in seal kit only

\*\* A four character suffix will appear at the end.

\*\*\* Order item #18 for O-rings req'd

Refer to Figure 5.

Key No.	No Req'd	BORE SIZE 80	BORE SIZE 80	BORE SIZE 100	BORE SIZE 100	BORE SIZE 100	BORE SIZE 120
		ROD 45	ROD 56	ROD 45	ROD 56	ROD 70	ROD 56
**1	1 1 1 1	TV82N□GA10B— TV82N□GF10B— TV82N□GC10B— TV82N□GL10B—	TV82Q□GA10B— TV82Q□GF10B— TV82Q□GC10B— TZ82Q□GL10B—	TV82N□HA10B— TV82N□HF10B— TV82N□HC10B— TV82N□HL10B—	TV82Q□HA10B— TV82Q□HF10B— TV82Q□HC10B— TV82Q□HL10B—	TV82S□HA10B— TV82S□HF10B— TV82S□HC10B— TV82S□HL10B—	TV82Q□KA10B— TV82Q□KF10B— TV82Q□KC10B— TV82Q□KL10B—
*2	1	7946-045	7946-056	7946-045	7946-056	7946-070	7946-056
3	1	TV81N□000	TV81Q□000	TV81N□000	TV81Q□000	TV81S□000	TV81Q□000
*4	1	7942-045	7942-056	7942-045	7942-056	7942-070	7942-056
*5	1	7944-045	7944-056	7944-045	7944-056	7944-070	7944-056
*6	2	5145-141-A	5145-151-A	5145-141-A	5145-151-A	5145-154-A	5145-151-A
7	1	SH-92-R-32	N/A	N/A	N/A	N/A	N/A
8	1	5194-250-DG-R	N/A	N/A	N/A	N/A	N/A
9	1	TV57GA _____	TV57GA _____	TV57HA _____	TV57HA _____	TV57HA _____	TV57KA _____
10	1	TV93NG1C	TV93QG1C	TV93NH1C	TV93QH1C	TV93SH1C	TV93QK1C
*11	1	7949-080	7949-080	7949-100	7949-100	7949-100	7949-125
*12	1	7948-080	7948-080	7948-100	7948-100	7948-100	7948-125
13	1	TV53GF0N7	TV53GF0Q7	TV53HF0N7	TV53HF0Q7	TV53HF0S7	TV53KF0Q7
*14	2	5145-152-A	5145-152-A	5145-155-A	5145-155-A	5145-155-A	5145-251-A
15	1	5194-125-DG	5194-75-DG	N/A	N/A	N/A	N/A
16	1	SH-92-B-32	SH-92-B-32	N/A	N/A	N/A	N/A
17	1 or 2	TV95-080	TV95-080	TV95-080	TV95-080	TV95-080	TV95-080
18	1 or 2	5335-020-A	5335-020-A	5335-020-A	5335-020-A	5335-020-A	5335-020-A
19	1	02-157950	02-157950	02-157950	02-157950	02-157950	02-157950
20 ***	1	TV98-080	TV98-080	TV98-080	TV98-080	TV98-080	TV98-080
*21	1	N/A	N/A	N/A	N/A	N/A	N/A
22 ***	A/R	TV94-080	TV94-080	TV94-080	TV94-080	TV94-080	TV94-080
23	1 per screw	7971-080	7971-080	7971-080	7971-080	7971-080	7971-080
24	1 per screw	7972-080	7972-080	7972-080	7972-080	7972-080	7972-080
25	1 per screw	7973-080	7973-080	7973-080	7973-080	7973-080	7973-080
26	A/R						
27	4	TV56 _ F _____	TV56 _ F _____	TV56 _ F _____	TV56 _ F _____	TV56 _ F _____	TV56 _ H _____
28	A/R	5305-014	5305-014	5305-014	5305-014	5305-014	5305-016

Notes:

\* Sold in seal kit only

\*\* A four character suffix will appear at the end.

\*\*\* Order item #18 for O-rings req'd.

Refer to Figure 5.

Key No.	Part Name	No Req'd	BORE SIZE 125	BORE SIZE 125	BORE SIZE 160	BORE SIZE 160
			ROD 70	ROD 90	ROD 70	ROD 90
**1	Piston rod (# = rod end type) Non-cushioned Cushioned head end Cushioned cap end Cushioned both ends Specify stroke	1 1 1 1	TV82S□KA10B___ TV82S□KF10B___ TV82S□KC10B___ TV82S□KL10B___	TV82U□KA10B___ TV82U□KF10B___ TV82U□KC10B___ TV82U□KL10B___	TV82S□LA10B___ TV82S□LF10B___ TV82S□LC10B___ TV82S□LL10B___	TV82U□LA10B___ TV82U□LF10B___ TV82U□LC10B___ TV82U□LL10B___
*2	Rod wiper (Normal sealing system option)	1	7946-070	7946-090	7946-070	7946-090
3	Rod bearing- Place appropriate code into # in part no. A = Normal sealing; B = Low friction/high temp.	1	TV81S□000	TV81U□000	TV81S□000	TV81U□000
*4	Rod seal (Normal sealing system option)	1	7942-070	7942-090	7942-070	7942-090
*5	Rod wear band	1	7944-070	7944-090	7944-070	7944-090
*6	Seal O.D. bearing	2	5145-154-A	5145-156-A	5145-154-A	5145-156-A
7	Cushion sleeve (Head end) (Rod end cushion cylinders only)	1	N/A	N/A	N/A	N/A
8	Retainer ring (Head end) (Rod end cushion cylinders only)	1	N/A	N/A	N/A	N/A
9	Body (Consult factory if intermediate trunnion mount) Specify stroke	1	TV57KA _____	TV57KA _____	TV57LA _____	TV57LA _____
10	Cushion collar	1	TV93SK1C	TV93UK1C	TV93SL1C	TV93UL1C
*11	Piston wear band	1	7949-125	7949-125	7949-160	7949-160
*12	Piston seal (Normal sealing system option)	1	7948-125	7948-125	7948-160	7948-160
13	Piston	1	TV53KF0S7	TV53KF0U7	TV53LF0S7	TV53LF0U7
*14	Body O-ring (Normal sealing system option)	2	5145-251-A	5145-251-A	5145-363-A	5145-363-A
15	Retainer ring (Cap end) (Cap cushioned cylinders only)	1	N/A	N/A	N/A	N/A
16	Cushion sleeve (Cap end) (Cap cushioned cylinders only)	1	N/A	N/A	N/A	N/A
17	Cushion adjusting screw (2 req'd if cushioned both ends)	1 or 2	TV95-080	TV95-080	TV95-160	TV95-160
18	Cushion adjusting O-ring (2 req'd if cushioned both ends)	1 or 2	5335-020-A	5335-020-A	5335-021-A	5335-021-A
19	Steel ball (1 req'd if cushioned head end)	1 or 2	02-157950	02-157950	02-157953	02-157953
20 ***	Ball retainer (1 req'd if cushioned head end)	1 or 2	TV98-080	TV98-080	TV98-160	TV98-160
*21	Back-up ring	1	N/A	TV80U0	N/A	TV80U0
22 ***	Air bleeder screw	A/R	TV94-080	TV94-080	TV94-160	TV94-160
23	Retaining plate – Ball check adj. screw	1 per screw	7971-080	7971-080	7971-160	7971-160
24	Retaining plate – Cushion adj. screw	1 per screw	7972-080	7972-080	7972-160	7972-160
25	Retaining plate – Air bleed adj. screw	1 per screw	7973-080	7973-080	7973-160	7973-160
26	Retaining plate drive screws (Included with retaining plate)	A/R				
27	Tie rods (Specify mtg. style/bore & stroke)	4	TV56 _ H _____	TV56 _ H _____	TV56 _ J _____	TV56 _ J _____
28	Tie rod nuts (Specify mtg. style/bore & stroke)	A/R	5305-016	5305-016	5305-018	5305-018

Notes:

\* Sold in seal kit only

\*\* A four character suffix will appear at the end.

\*\*\* Order item #18 for O-rings req'd



Refer to Figure 5.

Key No.	Part Name	No Req'd	BORE SIZE 160	BORE SIZE 200	BORE SIZE 200	BORE SIZE 200
			ROD 110	ROD 90	ROD 110	ROD 140
**1	Piston rod (# = rod end type) Non-cushioned Cushioned head end Cushioned cap end Cushioned both ends Specify stroke	1 1 1 1	TV82W□LA10B TV82W□LF10B TV82W□LC10B TV82W□LL10B	TV82U□NA10B TV82U□NF10B TV82U□NC10B TV82U□NL10B	TV82W□NA10B TV82W□NF10B TV82W□NC10B TV82W□NL10B	TV82Z□NA10B TV82Z□NF10B TV82Z□NC10B TV82Z□NL10B
*2	Rod wiper (Normal sealing system option)	1	7946-110	7946-090	7946-110	7946-140
3	Rod bearing- Place appropriate code into # in part no. A = Normal sealing; B = Low friction/high temp.	1	TV81W□000	TV81U□000	TV81W□000	TV81Z□000
*4	Rod seal (Normal sealing system option)	1	7942-110	7942-090	7942-110	7942-140
*5	Rod wear band	1	7944-110	7944-090	7944-110	7944-140
*6	Seal O.D. bearing	2	5145-161-A	5145-156-A	5145-161-A	5145-163-A
7	Cushion sleeve (Head end) (Rod end cushion cylinders only)	1	N/A	N/A	N/A	N/A
8	Retainer ring (Head end) (Rod end cushion cylinders only)	1	N/A	N/A	N/A	N/A
9	Body (Consult factory if intermediate trunnion mount) Specify stroke	1	TV57LA _____	TV57NA _____	TV57NA _____	TV57NA _____
10	Cushion collar	1	TV93WL1C	TV93UN1C	TV93WN1C	TV93ZN1C
*11	Piston wear band	1	7949-160	7949-200	7949-200	7949-200
*12	Piston seal (Normal sealing system option)	1	7948-160	7948-200	7948-200	7948-200
13	Piston	1	TV53LF0W7	TV53NF0U7	TV53NF0W7	TV53NF0Z7
*14	Body O-ring (Normal sealing system option)	2	5145-363-A	5145-369-A	5145-369-A	5145-369-A
15	Retainer ring (Cap end) (Cap cushioned cylinders only)	1	N/A	N/A	N/A	N/A
16	Cushion sleeve (Cap end) (Cap cushioned cylinders only)	1	N/A	N/A	N/A	N/A
17	Cushion adjusting screw (2 req'd if cushioned both ends)	1 or 2	TV95-160	TV95-160	TV95-160	TV95-160
18	Cushion adjusting O-ring (2 req'd if cushioned both ends)	1 or 2	5335-021-A	5335-021-A	5335-021-A	5335-021-A
19	Steel ball (1 req'd if cushioned head end)	1 or 2	02-157953	02-157953	02-157953	02-157953
20 ***	Ball retainer (1 req'd if cushioned head end)	1 or 2	TV98-160	TV98-160	TV98-160	TV98-160
*21	Back-up ring	1	5138-161	5138-156	5138-161	5138-168
22 ***	Air bleeder screw	A/R	TV94-160	TV94-160	TV94-160	TV94-160
23	Retaining plate – Ball check adj. screw	1 per screw	7971-160	7971-160	7971-160	7971-160
24	Retaining plate – Cushion adj. screw	1 per screw	7972-160	7972-160	7972-160	7972-160
25	Retaining plate – Air bleed adj. screw	1 per screw	7973-160	7973-160	7973-160	7973-160
26	Retaining plate drive screws (Included with retaining plate)	A/R				
27	Tie rods (Specify mtg. style/bore & stroke)	4	TV56 _ J _____	TV56 _ L _____	TV56 _ L _____	TV56 _ L _____
28	Tie rod nuts (Specify mtg. style/bore & stroke)	A/R	5305-018	5305-019	5305-019	5305-019

Notes:

\* Sold in seal kit only

\*\* A four character suffix will appear at the end.

\*\*\* Order item #18 for O-rings req'd

# How to Order

---

## Standard Cylinders

Vickers has created an easy system for ordering Series TV Cylinders. This system has been developed to improve our service to you. The model code consists of sixteen alpha-numeric digits which fully describe the most common standard options offered on Series TV cylinders.

To specify your Series TV cylinder, review the following pages for a full description of each option available and select the desired code.

This model code system will:

- **Simplify the re-order process.**  
Each Vickers Series TV cylinder is assigned a sixteen digit model code. That code is unique to a particular cylinder description. That way, when you re-order a Series TV cylinder, you're assured of exactly the same top quality cylinder design.
- **Improve identification.**  
Every Series TV cylinder has its sixteen digit model code clearly marked on the product, impression stamped in the metal head or cap. Each sixteen digit code completely describes a specific cylinder. This allows seals and replacement components to be easily identified in the field.
- **Facilitate communications.**  
This fully descriptive model code system allows you to work directly with your local Vickers sales engineer to identify and service your Vickers cylinder.

## Custom Cylinders

### New Cylinders

Although the model code has been arranged to cover the vast majority of available options, there will be occasions when you require an option which cannot be coded. When specifying such an option, enter an "X" for the appropriate item in the sixteen digit model code, then describe your requirements. For example, if you have an application which requires a custom thread on the end of the piston rod, enter an "X" for item 7. Then add a full description at the end of the model code, such as "With 3.25 inch total rod projection and M22 x 1.5 thread 1.375 inches long." The cylinder will then be given a unique five digit design number on receipt of order (as explained below).

### Replacement Cylinders

Every Vickers custom cylinder is assigned a unique design number. This number is contained in the last five digits of the sixteen digit model code, and item 12 is always a alpha character (see page 19). In other words, the "Stroke" and "Extra Rod Projection" locations (items 12 through 16) become the "Design Number" items for custom cylinders. When ordering a replacement cylinder, simply give the sixteen digit model code or the five digit design number to your local Vickers Sales Representative.

### Replacement Parts

Each design number is stored in a quick retrieval computerized storage system. This gives our field sales representatives rapid access to assist you in identifying and specifying genuine Vickers replacement parts.

# Model Code

(All dimensions are in mm)

## TV 17 HN 7 N 7 K W 108 PC

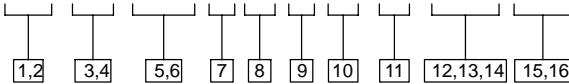

### 1,2 Series

TV – ISO 6020-2 / DIN 24554  
Interchangeable hydraulic cylinder

### 3,4 Mounting style

Code Mounting style

01<sup>D</sup>  
(MS2<sup>D</sup>)

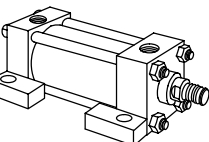

04 Keyed Side Lug

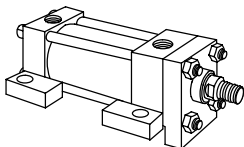

07<sup>D</sup>  
(ME5<sup>D</sup>)  
Head DIN Rectangular  
Flange

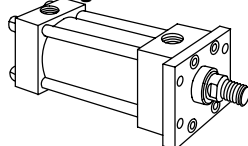

09  
(ME5  
)  
Head ISO Rectangular

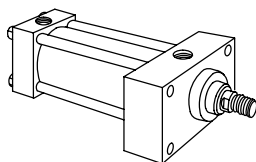

10  
(MP1  
)  
Cap Clevis

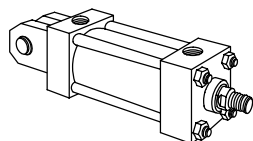

Code Mounting style

11<sup>D</sup>  
(MP5<sup>D</sup>)  
Cap Rectangular Flange

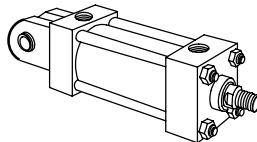

14<sup>D</sup>  
(ME6<sup>D</sup>)  
Cap Rectangular

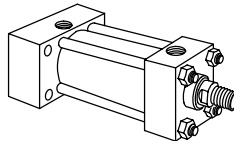

15<sup>D</sup>  
(MT4<sup>D</sup>)  
Intermediate Trunnion

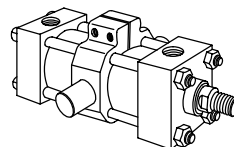

16  
(MT2)  
Cap Trunnion

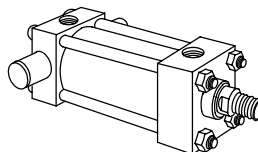

17  
(MT1)  
Head Trunnion

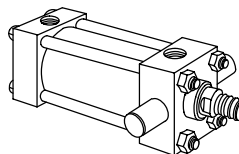

21  
(MX2  
)  
Cap Extended Tie Rod

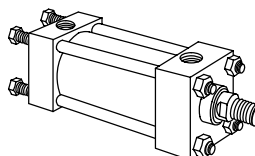

Code Mounting style

22  
(MX3  
)  
Head Extended Tie Rod

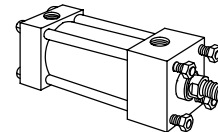

23  
(MX1  
)  
Both Ends Ex-  
tended  
Tie Rod

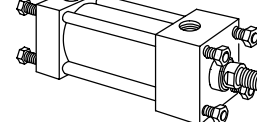

25 Double Rod, Side Lug

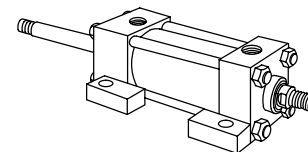

47  
(MP3  
)  
Cap Fixed Eye

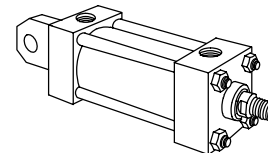

### Code Other mounting styles

- 24 No Mount
- 33 Double Rod Rectangular
- 34 Double Rod Intermediate Trunnion
- 35 Double Rod Head Trunnion
- 39 Double Rod Extended Tie Rod
- 40 Double Rod Both Ends Extended Tie Rod
- 41 Double Rod No Mount

<sup>D</sup> Conforms to DIN 24554

# Model Code

(All dimensions are in mm)

## TV 17 HN 7 N 7 K W 108 PC

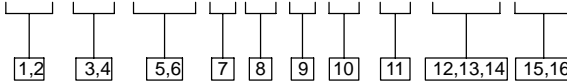

### 5,6 Bore and rod diameters

Code	Bore	Rod
BB –	25	12
BE –	25	18
2C –	32	14
2G –	32	22
CE –	40	18
CG –	40	22
CJ –	40	28
DG –	50	22
DJ –	50	28
DL –	50	36
EJ –	63	28
EL –	63	36
EN –	63	45
GL –	80	36
GN –	80	45
GQ –	80	56
HN –	100	45
HQ –	100	56
HS –	100	70
KQ –	125	56
KS –	125	70
KU –	125	90
LS –	160	70
LU –	160	90
LW –	160	110
NU –	200	90
NW –	200	110
NZ –	200	140

### 7 Rod end type - metric

Code	Rod End Style
<b>0</b> Intermediate male metric thd.	
<b>1</b> Short female metric thread	
<b>6</b> Plain no attachment	
<b>7</b> Small male metric thread	
<b>L</b> Extended small male metric thread	
<b>N</b> Extended intermediate male metric thread	

### 8 Sealing system

Code	Fluid Type
<b>N</b> –	Normal
<b>L</b> –	Low friction and water glycol
<b>T</b> –	High temperature

### 9 Ports

For maximum reliability, SAE ports are recommended.

Code	Port Style
<b>3</b> SAE/UN O-ring	Straight thread O-ring seal port
<b>4</b> Oversize SAE/UN O-ring	When boss is required
<b>5</b> NFPA standard SAE/UN O-ring	Straight thread O-ring seal port
<b>6</b> SAE 4-bolt manifold	
<b>7<sup>D</sup></b> BSPP	
<b>8</b> Oversize BSPP	When boss is required
<b>9</b> Metric	
<b>0</b> Oversize metric	When boss is required
<b>A</b> ISO 6149-1 O-ring	Straight thread O-ring seal port
<b>B</b> Oversize ISO 6149-1 O-ring	When boss is required

<sup>D</sup> Conforms to DIN 24554

**10 Port location**

Ports are located as shown below when viewing cylinder from head end (mounting end of double rod cylinder).

With some mounting styles, certain port locations cannot be selected due to interference with the mounting.

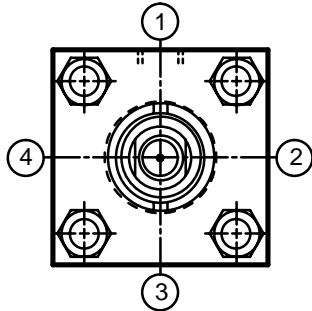

Code	Head	Cap
K <sup>D</sup> -	1	1
L -	1	2
M -	1	3
N -	1	4
P -	2	1
R -	2	2
S -	2	3
T -	2	4
U -	3	1
V -	3	2
W -	3	3
Y -	3	4
1 -	4	1
2 -	4	2
3 -	4	3
4 -	4	4

**11 Cushion location**

Cushions are located as shown in item 10 when viewing cylinder from head end (mounting end of double rod cylinders). “-” in table indicates no cushion.

Code	Head	Cap
A -	-	-
B -	-	1
C -	-	2
D -	-	3
E -	-	4
F -	1	-
G -	2	-
H -	3	-
J -	4	-
K -	1	1
L -	1	2
M -	1	3
N -	1	4
P -	2	1
R <sup>D1</sup> -	2	2
S -	2	3
T -	2	4
U -	3	1
V -	3	2
W <sup>D</sup> -	3	3
Y -	3	4
1 -	4	1
2 -	4	2
3 -	4	3
4 -	4	4

**12,13,14 Stroke length**

Items 12, 13, 14 indicate stroke length from 001 millimeters through 999 millimeters.

**15,16 Enter applicable code for either:**

**Extra rod projection (“C” dimension)**

Item 15 and 16 indicate extra rod projection from 00 through 99 mm.

- or -

**Air bleed or proximity switch location**

Item 15 indicates air bleeds (H)<sup>D</sup> gland drains (G), or proximity switches (P).

Item 16 indicates location of air bleeds, gland drain\*, or proximity switches as shown in item 10 when viewing cylinder from head end (mounting end of double rod cylinders). “-” in table indicates no air bleed or proximity switch.

Code	Head	Cap
B -	-	1
C -	-	2
D -	-	3
E -	-	4
F* -	1	-
G* -	2	-
H* -	3	-
J* -	4	-
K -	1	1
L -	1	2
M -	1	3
N -	1	4
P -	2	1
R <sup>D1</sup> -	2	2
S -	2	3
T -	2	4
U -	3	1
V -	3	2
W <sup>D</sup> -	3	3
Y -	3	4
1 -	4	1
2 -	4	2
3 -	4	3
4 -	4	4

\* Gland drain optional on Head only.

<sup>D</sup> Conforms to DIN 24554

<sup>D1</sup> Conforms to DIN 24554 for TV01 (MS2) mounting only,