

Eaton®
Gear Motors

 www.khadamahydraulic.com
Tell: 021-55882749
Tell: 021-33488178
Fax: 021-33488105

No. 7-133
Revised February, 1990

EATON

Repair Information

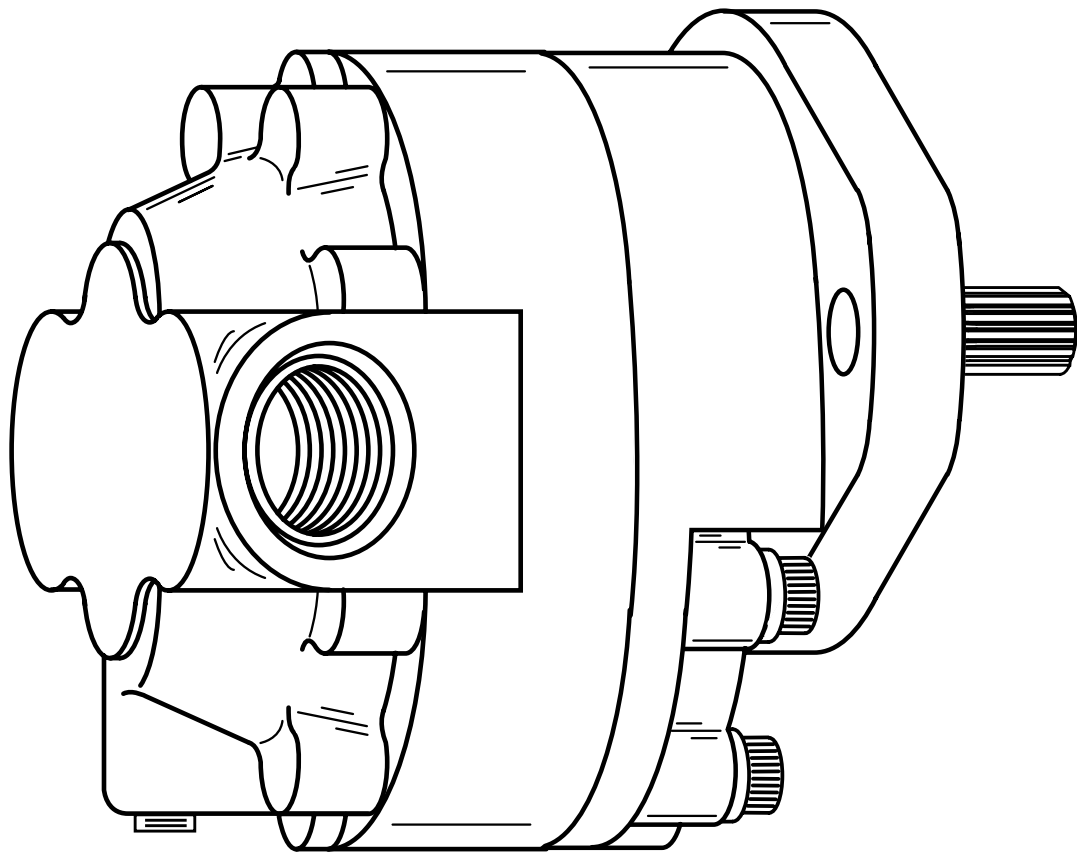

Model 21300 Gear Motor "B1" Series

 www.khadamahydraulic.com
Tell: 021-55882749
Tell: 021-33488178
Fax: 021-33488105

Parts Drawing

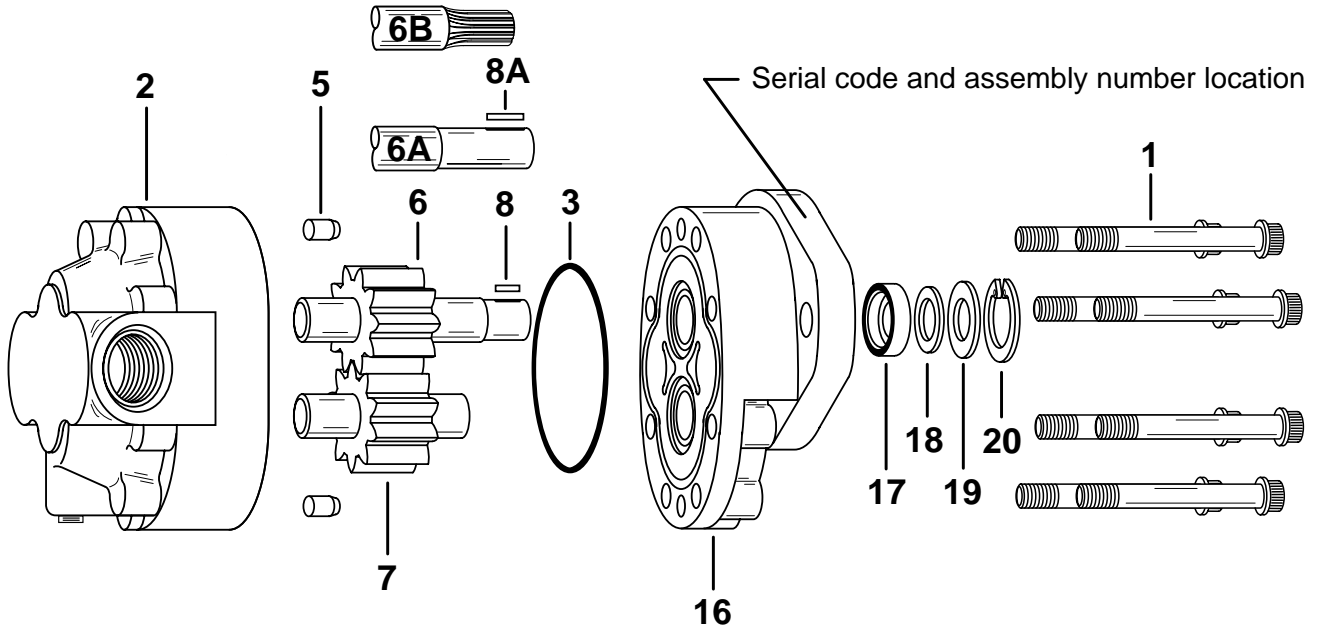

Parts List

| Item No. | Description | Qty |
|----------|---|-----|
| 1 | Cap screws | 8 |
| 2 | Housing Assembly | 1 |
| + *3 | O-ring, 1/16 in. Dia. x 3 in. I.D. [1,59mm Dia. x 76,2mm I.D.] | 1 |
| 5 | Dowel Pin | 2 |
| 6 | Drive Gear Assembly | 1 |
| 7 | Idler Gear Assembly | 1 |
| 8 | Key, .50 [12.7] Lg. | 1 |
| 8A | Key, .97 [24.6] Lg. | 1 |
| 16 | Front Plate Assembly | 1 |
| + 17 | Shaft Seal | 1 |
| + 18 | Back-up Washer | 1 |
| + 19 | Washer | 1 |
| + 20 | Retaining Ring | 1 |
| + *S | Seal Repair Kit (21300-923) | 1 |

+ Included in Seal Repair Kit

* Units built before mid 1985 may require o-ring 16015-551, 3/32 in. dia. x 3 in. I.D., provided in seal repair kit.

Tools Required for Disassembly and Reassembly

- 3/8 in., 12 Point Socket
- Ratchet Wrench
- Torque Wrench (100 lb-ft)
- Screwdriver
- Soft Face Hammer
- Seal Driver or Similar Tool
- Light Petroleum Jelly

Repair Information - Model 21300

Work in a clean area, cleanliness is extremely important when repairing hydraulic motors. Before disconnecting the lines, clean port area of motor. Disconnect hydraulic lines, removing motor assembly from vehicle and plug ports. Thoroughly clean the outside of motor. After cleaning, remove port plugs and drain oil.

Disassembly

- 1 Remove key from drive shaft if keyed drive gear assembly(6 or 6A) is used.
- 2 Put a location mark across front plate and housing assembly. This will assure proper reassembly.
- 3 Clamp motor in vise, shaft end up.
- 4 Remove cap screws(1) eight each.
- 5 Remove motor from vise, hold motor in hands and bump shaft against wooden block to separate front plate(16) from housing (2).
- 6 Remove drive gear assembly(6) and idler gear assembly(7) from housing assembly.
- 7 Remove o-ring (3), retaining ring (20), washer (19), back-up washer (18),and shaft seal (17) from front plate(16).
- 8 Do Not Remove check valves in the side ported housing assemblies. Located in both ports as shown below. Note check valves are loctited in.

Note: Check Valves are Loctited in position. Do Not Remove

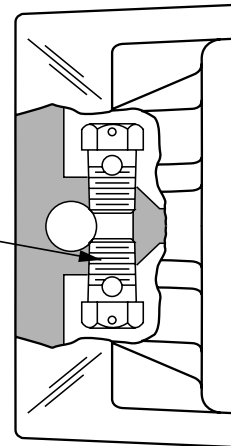

Inspect Parts for Wear

General

- 1 Clean and dry all parts.
- 2 Remove all nicks and burrs from all parts with emery cloth.
- 3 Replace gear assembly if shaft measures less than .686 in. [17,42mm] in bushing area. (one gear assembly may be replaced separately; shafts and gears are available as assemblies only.)

Gear Assembly

- 1 Check spline drive shaft for twisted or broken teeth or check keyed drive shaft for broken or chipped keyway.
- 2 Inspect both the drive gear and idler gear shafts at bushing points and seal area for rough surfaces and excessive wear.
- 4 Inspect gear face for scoring and excessive wear.
- 5 Replace gear assembly if gear width is below the following dimensions. Refer to chart on this page.
- 6 Assure that retaining rings are in grooves on either side of drive and idler gears.
- 7 If edge of gear teeth are sharp, break edge with emery cloth.

| | Model Number | | | | | | | | |
|--|----------------|----------------|-----------------|-----------------|-----------------|-----------------|-----------------|------------------|------------------|
| | 21300 | 21301 | 21302 | 21303 | 21304 | 21305 | 21306 | 21307 | 21308 |
| Pump Disp. cu. in./rev. [mL/rev.] | .40 [6,6] | .49 [8,0] | .58 [9,5] | .70 [11,5] | .84 [13,8] | 1.02 [16,7] | 1.24 [20,3] | 1.48 [24,3] | 1.77 [29,0] |
| Gear Width inches [millimeters] | .310 [7,87] | .371 [9,42] | .441 [11,20] | .535 [13,59] | .636 [16,15] | .767 [19,48] | .924 [23,47] | 1.107 [28,12] | 1.327 [33,71] |

Inspection Continued

Front Plate and Housing Assembly

1 Inspect I.D. of bushing in housing and front plate. Replace the housing or front plate if I.D. of bushings exceed .693 in. [17,6mm] (Bushings are not available as separate items).

2 Bushings in front plate are pressed .045 in. [1,14mm] below the face of the front plate.

3 Check for scoring on the inside face of housing assembly and face of front plate. Replace if wear exceeds .0015 in. [0,038mm].

4 Check gear pockets inside housing for excessive scoring or wear. Replace if I.D. of gear pockets exceeds 1.719 in. [43,5mm].

5 Inspect check valves within the side port housing. Visually checking to make sure check valves are secure. If not replace housing.

Reassembly

1 Replace the shaft seal and o-ring as new parts.

2 Install new o-ring (3) in groove of front plate (16).

3 Dip gear assemblies into oil and slip into front plate bushings.

4 Apply a thin coat of petroleum jelly to both milled gear pockets of housing (2).

5 Slide housing (2) over gears and shafts until dowel pins are engaged. Make sure location mark on housing and front plate match.

6 Secure with cap screws (1). Tighten evenly in a crisscross pattern to 22 to 25 lbs. ft.[29,8 to 33,9 N·m] torque.

7 Liberally oil shaft seal(17) and install over drive shaft, carefully so that rubber sealing lips are not cut. Place back-up washer(18) and washer(19) over drive shaft and onto shaft seal. Place a sleeve over shaft and press in shaft seal and washers until retaining ring groove appears.

8 Place retaining ring (20) into housing. Using sleeve again to press retaining ring in until it seats in groove.

9 Install key on keyed shaft.

Placing Motor Back Into Operation

When placing a rebuilt motor back into operation, it is important to follow the break-in procedure to prevent damaging the motor. If at all possible, run the motor at operating R.P.M. for 10 minutes with the motor disconnected from the machine. If the motor cannot be run without being connected to the machine, make all the necessary connections and run motor at operating R.P.M. for 10 minutes at minimal load. Increase the load

on the motor and run for 3 minutes at operating R.P.M. Place a full load on motor and run for 3 minutes at operating R.P.M. Idle engine and inspect for external leaks and check to be sure that all connections are tight. NOTE: If dual rotation motor, run in both directions during break in procedure. The motor is now ready to be placed back into service.

Trouble Shooting 21300 Motor

| Problem | Possible Causes | Correction |
|-------------------------|--|--|
| 1. Erratic motor R.P.M. | <ul style="list-style-type: none"> a. Oil supply low. b. Oil too heavy. c. Oil filter plugged. | <ul style="list-style-type: none"> a. Fill reservoir. b. Change to proper viscosity. c. Clean filters. |
| 2. Oil heating | <ul style="list-style-type: none"> a. Oil supply low. b. Contaminated oil. c. Setting of relief valve too high or too low. d. Oil in system too light. | <ul style="list-style-type: none"> a. Fill reservoir. b. Drain reservoir and refill with clean oil. c. Set to correct pressure. d. Drain reservoir and refill with proper viscosity oil. |
| 3. Shaft seal leakage. | <ul style="list-style-type: none"> a. Worn shaft seal. b. Bushings out of position c. Excessive internal wear. | <ul style="list-style-type: none"> a. Replace shaft seal. b. & c. If replacing the shaft seal does not stop leakage. the motor should be disassembled and checked for items b. and c. under causes. |
| 4. Foaming oil. | <ul style="list-style-type: none"> a. Low oil level. b. Air leaking into suction line of pump. c. Wrong kind of oil. | <ul style="list-style-type: none"> a. Fill reservoir. b. Tighten fittings. c. Drain and fill reservoir with non-foaming oil. |

