

**Eaton**<sup>®</sup>  
Hydrostatic Pumps

 [www.khadamathydraulic.com](http://www.khadamathydraulic.com)  
Tell: 021-55882749  
Tell: 021-33488178  
Fax: 021-33488105

No. 7-606  
March, 1995

**EATON**

## Repair Information

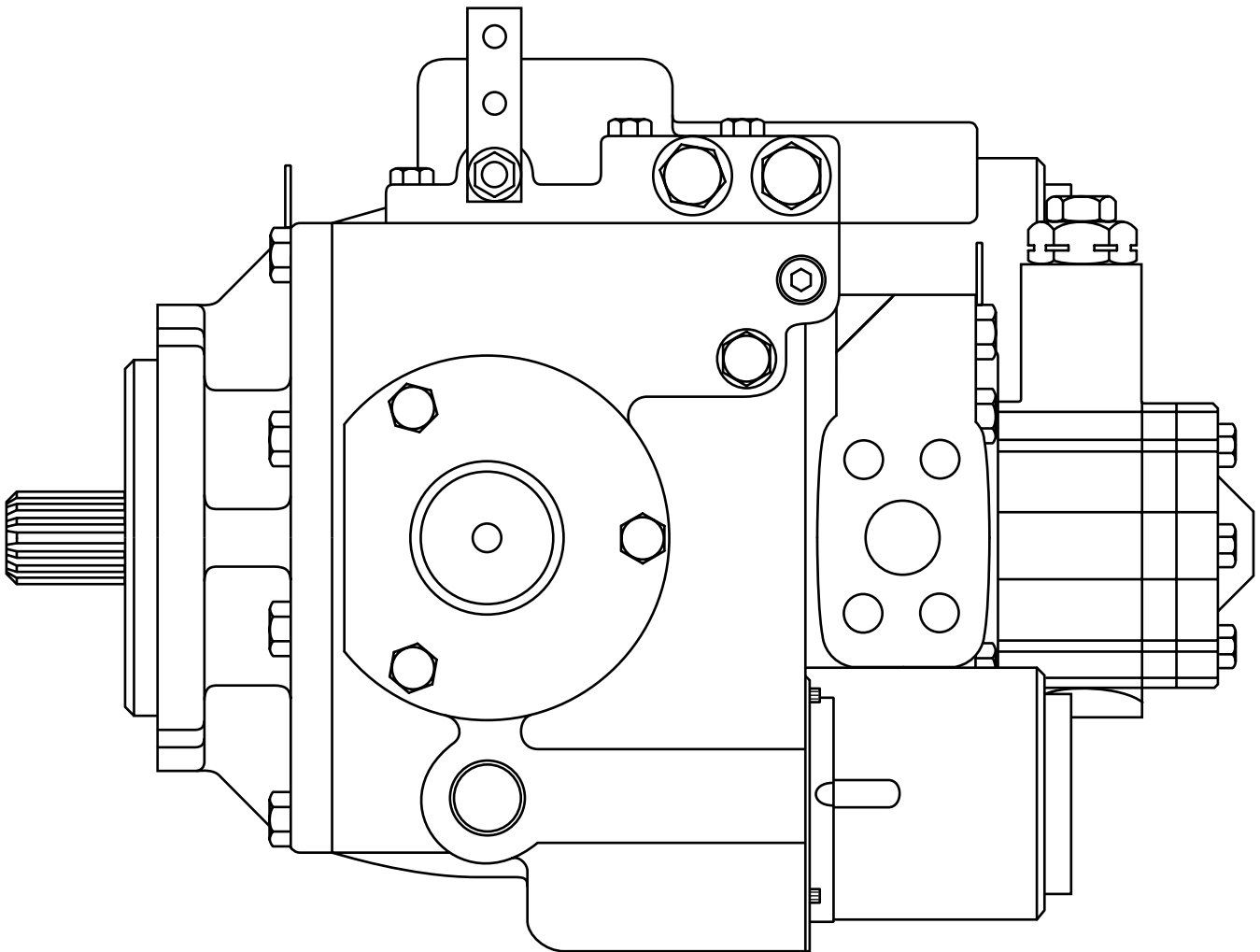

### Series 1 Models 33-64 Hydrostatic Variable Pumps

 [www.khadamathydraulic.com](http://www.khadamathydraulic.com)  
Tell: 021-55882749  
Tell: 021-33488178  
Fax: 021-33488105

## Table of Contents

	page
Introduction .....	2
ID Tag .....	3
Required Tools .....	3
Exploded View Drawing and Part Names .....	4
Disassembly .....	6
Reassembly .....	12
Appendix A: IPOR End Cover .....	21
Appendix B: Power Limiter Valve End Cover .....	22
Appendix C: Control Orifice Installation and Removal .....	23
Appendix D: Charge Pump Repair .....	24
Appendix E: Special Tools .....	25
Hydraulic Fluid Requirements .....	27

---

## Introduction

This manual provides service information for Eaton Models 33 thru 64 Variable Pumps. Step by step instructions for the complete disassembly, inspection and reassembly of the pump are given. The following recommendations should be followed to insure successful repairs:

- Most repairs require the removal of the pump from the vehicle.
- Cleanliness is extremely important.
- Clean the port areas thoroughly before disconnecting the hydraulic lines.
- Plug the pump ports and cover the open hydraulic lines immediately after they're disconnected.
- Drain the oil and clean the exterior of the pump before making repairs.
- Wash all metal parts in clean solvent.
- Use compressed air to dry the parts. Do not wipe them dry with paper towels or cloth; Lint in a hydraulic system will cause damage.
- The compressed air should be filtered and moisture free.
- Always use new seals when reassembling hydraulic pumps.
- For replacement parts and ordering information refer to parts list 6-608.
- Lubricate the new rubber seals with a petroleum jelly like Vaseline before installation.
- Torque all bolts over gasketed joints, then repeat the torquing sequence to make-up for gasket compression.
- **Verifying the accuracy of pump repairs on an authorized test stand is essential.**

## ID Tag

### A - Displacement (cu.in./rev.)

0033 = 3.3  
0039 = 3.9  
0046 = 4.6  
0054 = 5.4  
0064 = 6.4  
0076 = 7.6

### B - Identifies Type of Product

21 = Variable Displacement Pump  
31 = Fixed Displacement Motor  
41 = Variable Displacement Motor  
61 = Tandem Variable Displacement Pumps

### C - Identifies Specific Unit Configuration

### D - Month of Manufacture

### E - Year of Manufacture

### F - Specific Serial Number of Unit

### G - Identifies Direction of Input Shaft

(Pumps Only) Rotation

Observed from Shaft End of Unit

CW = Clockwise

CCW = Counterclockwise

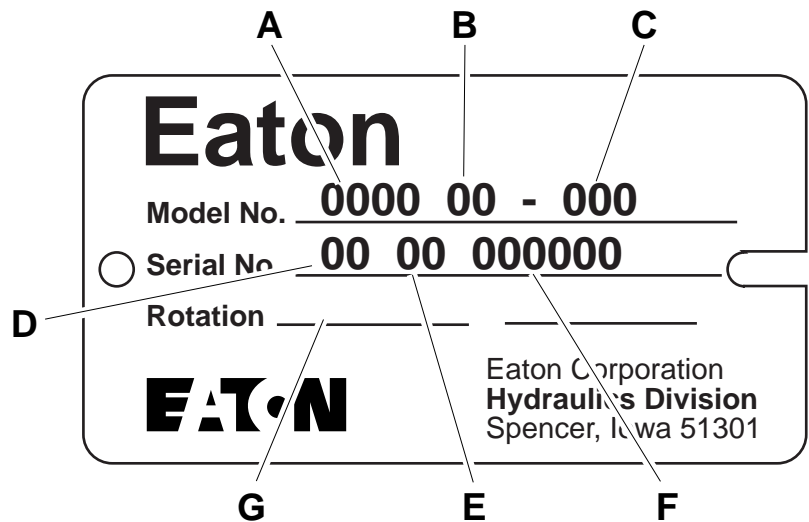

## Required Tools

- 9/64 in. Hex Key
- 1/4 in. Hex Key
- 1/2 in. Socket
- 9/16 in. Socket
- 5/8 in. Socket
- 3/4 in. Socket
- 7/8 in. Socket
- 1 in. Socket
- 1-3/8 in. Socket
- Dial Indicator with Magnetic Base
- Spring Compression Scale (0-10 lbs)
- No. 5 or 7 Retaining Ring Pliers
- Small Pair of External Retaining Ring Pliers (45° or 90°)
- Adjustable joint Pliers
- 3 in.X 1/4-20 Bolt
- Breaker Bar or Ratchet Wrench
- Torque Wrench (200 lb-ft capacity)
- 18 to 20 in. Adjustable Wrench
- Shaft End Spacer (Special)
- Hammer ( steel and Plastic)
- Depth Micrometer with Extensions
- Parallel Bars
- Slide Hammer
- Split Blade Bearing Puller
- Prick Punch
- Scribe
- Punch
- Arbor Press
- Clean, Lint Free Cloths
- Loctite
- Light Petroleum Jelly
- Suitable Solvents and Cleaners
- Rotating Seal Puller (Special)
- Low Clearance Bearing Puller (Special)
- Bearing Cone Driver (Special)
- Check Valve Puller (Special)

Special Tools are shown on pages 25 and 26.

# Exploded View Drawing

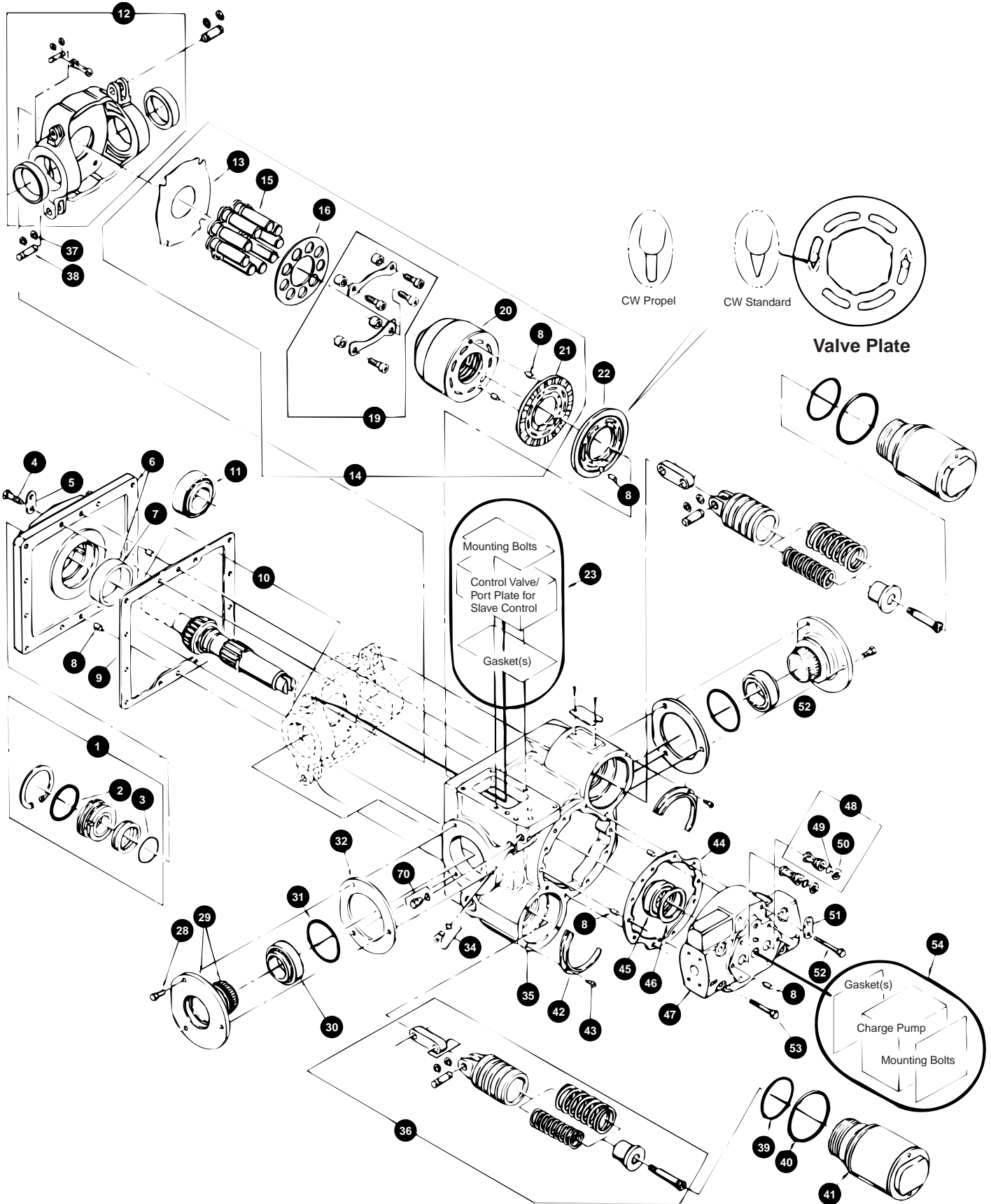

### Models 33 thru 64 Variable Pump Parts

Item No.	Description	Qty.	Item No.	Description	Qty.
1	Shaft Seal Kit	1	31	O-ring	2
2	O-ring	1	32	Trunnion Shims	◆
3	O-ring	1	34	Plug and O-ring	1
4	Mounting Flange Bolt	12	35	Pump Housing	1
5	Shipping Strap	2	36	Servo Piston S/A	2
6	Mounting Flange S/A	1	37	Retaining Ring	8
7	Bearing Cup	1	38	Pin	4
8	Dowel Pin	9	39	O-ring	2
9	Mounting Flange Gasket	1	40	O-ring	2
10	Drive Shaft S/A	1	41	Servo Sleeve	2
11	Replacement Bearing Kit	◆	42	Servo Sleeve Retainer	2
12	Swashplate S/A	1	43	Cap Screw	6
13	Thrust Plate	1	44	End Cover Gasket	1
14	Rotating Group	1	45	End Cover Bearing	1
15	Piston and Slipper S/A	9	46	Shaft Shims	◆
16	Slipper Retainer Plate	1	47	End Cover	1
19	Retaining Strap and Bolts	2	48	Check Valve S/A	2
20	Cylinder Barrel	1	49	O-ring	2
21	Bearing Plate	1	50	Back-up Ring	2
22	Valve Plate	1	52	End Cover Bolt	6
23	Control Valve Option	1	53	End Cover Bolt	2
28	Trunnion Bolt	6	54	Charge Pump	1
29	Trunnion S/A	2	70	Plug and O-ring	1
30	Replacement Bearing Kit	◆			

◆ Parts used as required.

## Hydrostatic Variable Pump Repairs

### Disassembly

Due to the complexity of the heavy duty pump certain subassemblies are disassembled, inspected, and reassembled upon removal from the pump. This procedure insures repair accuracy and helps avoid the loss of small parts.

- 1 Clean the exterior of the pump and drain the oil.
- 2 Position the pump so the shaft seal is accessible.

**Important:** Cleanliness is extremely important; be sure that no contaminants get into the pump.

- 3 Using a retaining ring pliers remove the retaining ring.

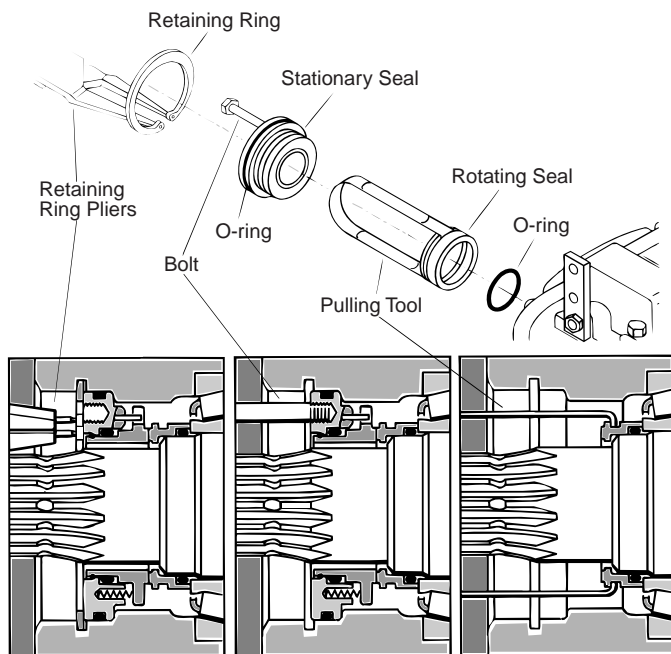

Figure 1

- 4 Screw a 3 in. X 1/4-20 bolt into the threaded hole in the stationary seal. Pull on the bolt to remove the seal.

5 Use the special pulling tool, Owatonna Tool Co. P/N CAS 1844, to remove the rotating seal, see figure 1. If the special tool is not available pull out the rotating seal with a wire bent to the shape of the puller.

**Note:** Detailed drawings of all special tools are given in Appendix E, in the back of this manual.

- 6 Remove the o-ring; it will either be in the rotating seal or on the shaft.

**Note:** If you are just replacing the shaft seal jump ahead to step 105 on page 20.

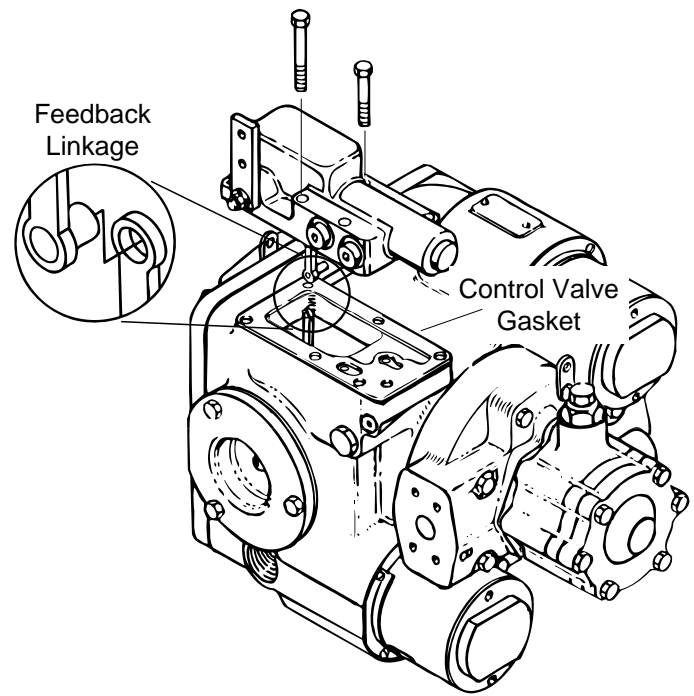

Figure 2

- 7 Remove the six hex head bolts that hold the control valve to the pump.

8 Lift the control valve away from the pump and disengage the feedback linkage, see figure 2.

- 9 Remove the control valve gasket.

10 Inspect the control valve: Start by thoroughly flushing the control valve with clean solvent. Then blow it dry with compressed air. Be sure to blow through all of the control valve's internal passages.

Inspect the control valve linkage. Move the control lever back and forth; it should move freely without binding. There should be no free play in the feedback link or control lever.

Check the control valve orifice; if it is plugged after flushing clean or replace it. Appendix C gives information on orifice replacement.

**Important:** The control orifice may be installed in different locations depending on which pump control is used. If it is removed a new orifice must be installed in the same location.

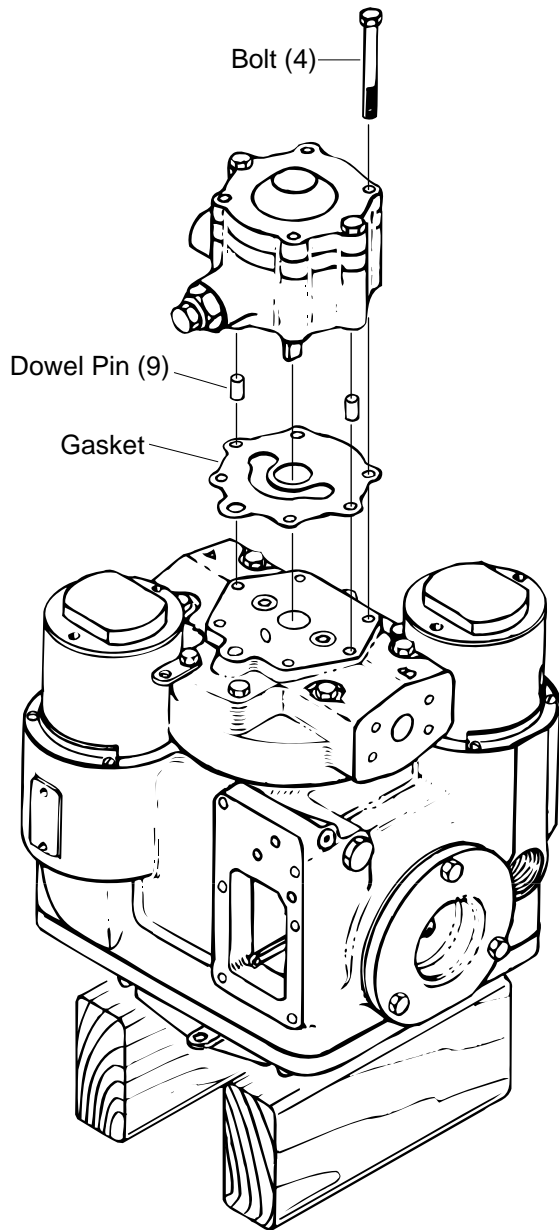

Figure 3

**11** Reposition the pump so the shaft is vertical and the charge pump is on top. Stand the pump on two blocks of wood as shown in figure 3.

**12** Remove the four bolts that hold the charge pump to the end cover, see figure 3. The two remaining bolts hold the charge pump together.

**Note:** Information on charge pump repair is given in Appendix D.

**13** Lift the charge pump from the end cover. Remove the gasket and two dowel pins.

**Note:** Keep track of the dowel pins, see figures 3, 5, and 8. There is a total of nine dowel pins in the pump. It is a good idea to put them in a small box so they don't get lost.

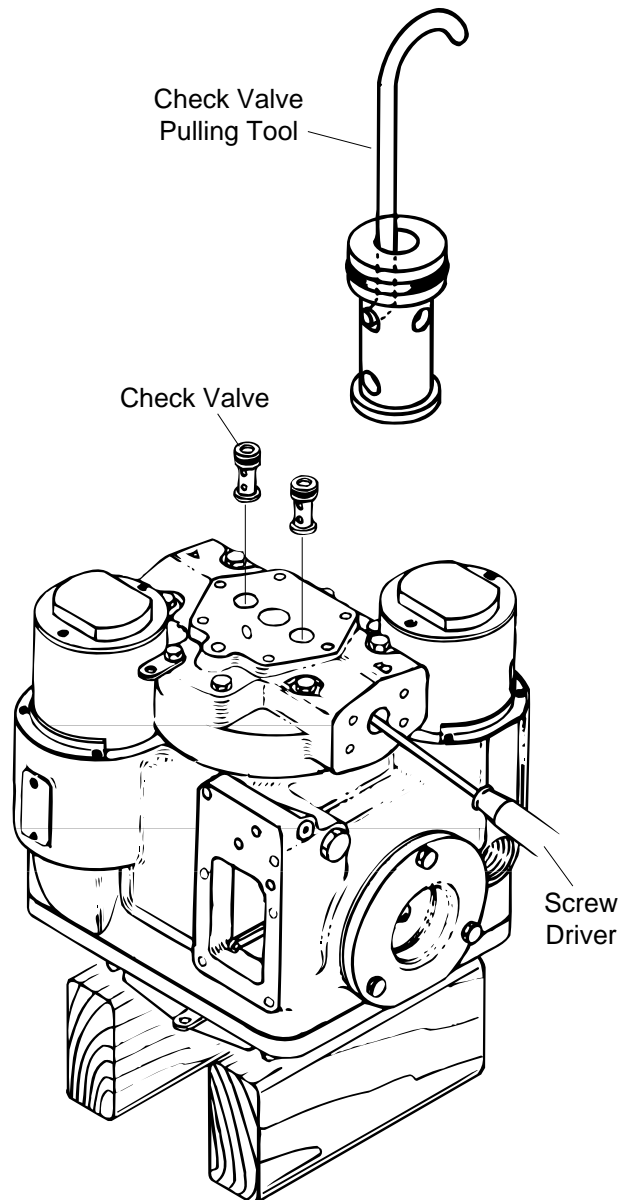

Figure 4

**14** Pull the two check valves from the end cover; Hook the short end of the pulling tool in one of the check valve cross holes, see figure 4.

If the pulling tool is unavailable remove each check valve by inserting a screw driver into the output port and prying up on the bottom of the check valve.

**Note:** A detailed drawing of the check valve pulling tool is given in Appendix E.

**15** Remove the o-rings and back-up rings from the check valves.

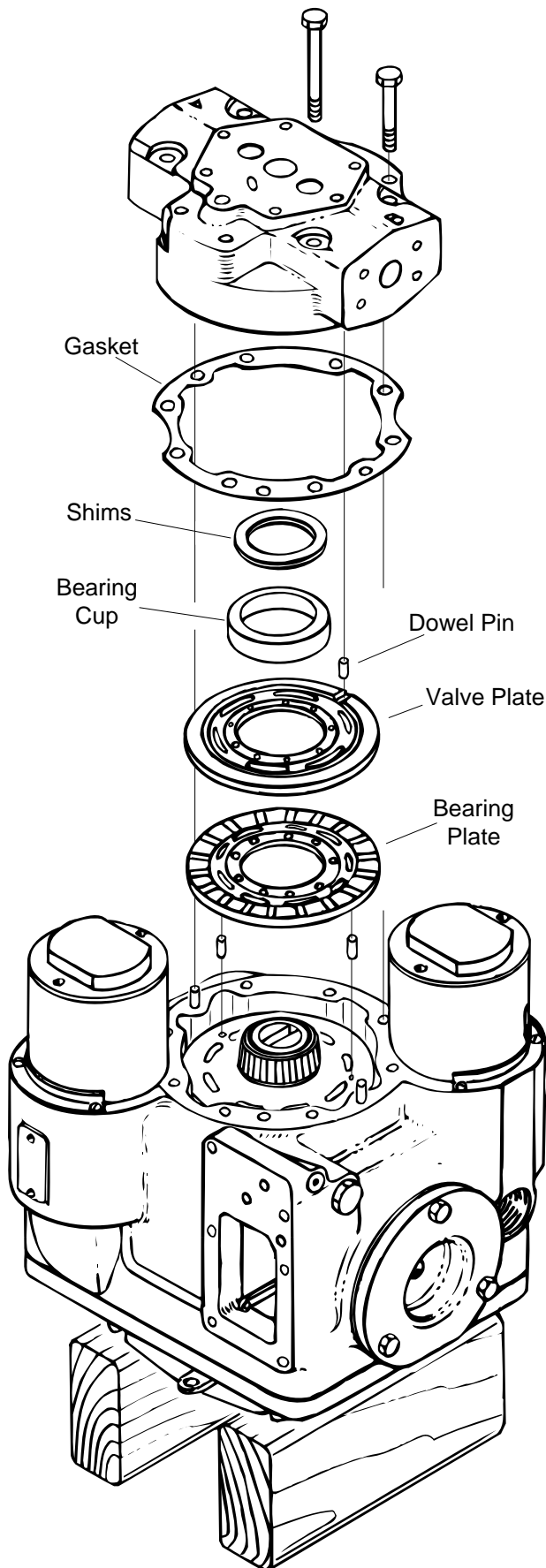

Figure 5

**16** Remove the end cover.

**Caution:** The cylinder barrel spring pre-load will damage the pump's internal parts if the end cover is removed incorrectly.

Start by removing six of the eight bolts that hold the end cover to the pump. Leave two bolts that are directly across from each other tight.

Next, loosen the two remaining bolts one or two turns. The end cover should rise as the bolts are loosened. If it doesn't tap it with a plastic hammer to break the gasket seal.

After the gasket seal is broken loosen the bolts gradually and evenly until the cylinder barrel spring pre-load is relieved.

Remove the bolts and lift the end cover from the pump. Be careful; do not drop the valve plate, it may lift away with the end cover.

**Important:** Use care when handling the pump's internal parts. They are machined to extremely close tolerances.

**17** Turn the end cover over and set it on a clean cloth.

**Important:** Always protect machined surfaces.

**Note:** The standard end cover is shown in figure 5. Two optional end covers are available. Use the same removal procedure for the optional end covers. Breakdowns of the optional end covers are shown in the appendices:

Optional End Cover	Appendix	Page
IPOR	A	21
Power Limiter Valve	B	22

**18** Remove the valve plate and dowel pin; they will either be on the end cover or bearing plate.

**Note:** Pump valve plates are unidirectional and must be matched to the input direction of the pump. The metering slots indicate the valve plate's direction, see figure 6. Also be aware that there are different shaped metering slots; 'V' shaped metering slots are standard, and kidney shaped metering slots are on propel valve plates.

**19** The bearing cup is slip-fit into the end cover. The shims under the bearing cup adjust the shaft end play. It is not necessary to remove these parts at this time.

**20** Remove the bearing plate.

**21** Remove the end cover gasket.



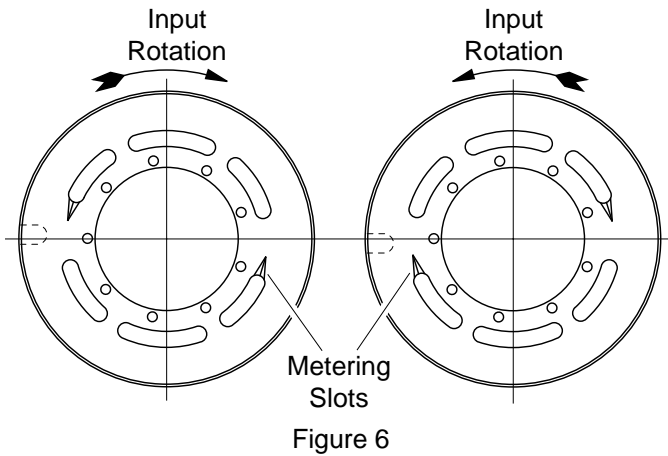

Figure 6

**22** Remove the two dowel pins from cylinder barrel face, see figure 5.

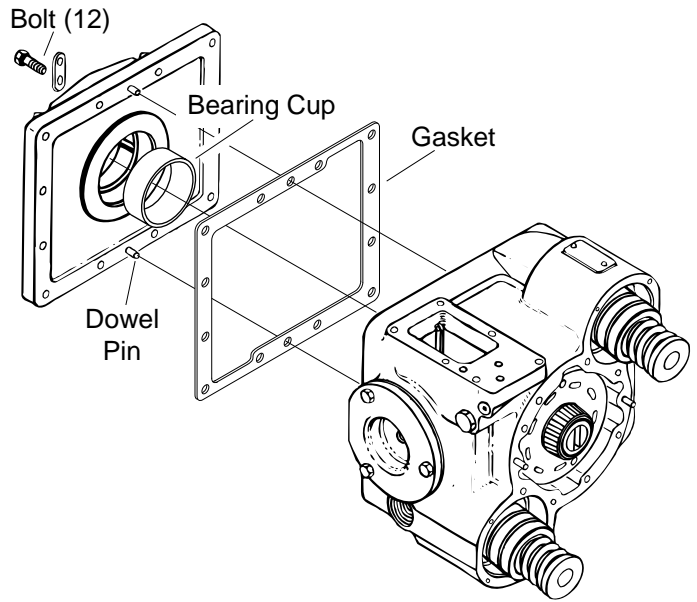

Figure 8

**28** Reposition the pump so the control valve mount is on top.

**29** Remove the twelve hex head bolts that hold the mounting flange to the pump.

**30** Remove the mounting flange, tapping it with a plastic hammer will help to break it loose.

**31** Remove the mounting flange gasket.

**Note:** Do not remove the bearing cup from the mounting flange unless it is damaged. Go to step 34 if the bearing cup is undamaged.

**32** Use an internal bearing puller or a long punch to remove the old bearing cup. Be careful; do not damage the mounting flange.

**33** Press the new bearing cup into the mounting flange. Be sure that it is pressed all the way to the bottom of the recess.

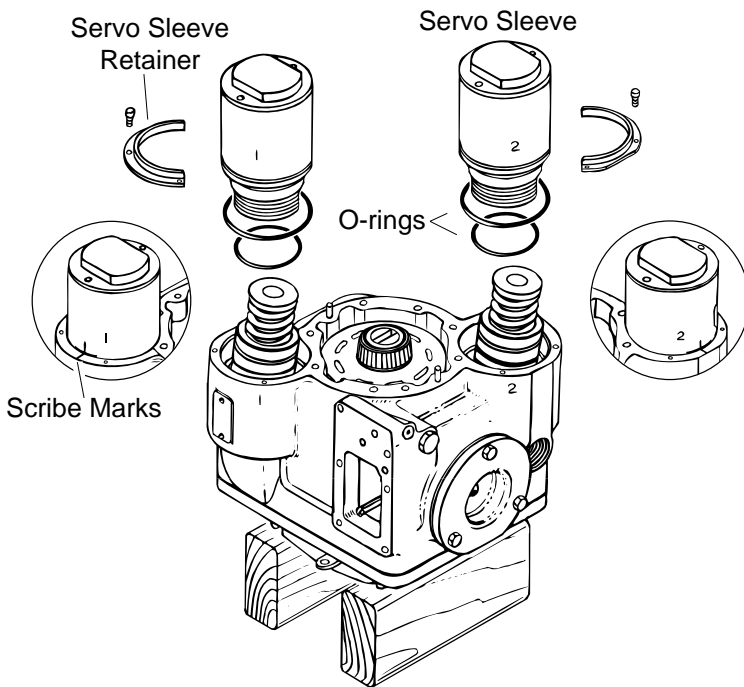

Figure 7

**23** Mark the pump housing and servo sleeves so they can be reinstalled in the same locations.

**24** Remove the servo sleeve retainers.

**25** Scribe position marks on each servo sleeve; Make a horizontal line where the servo sleeve and pump housing meet. Then make a vertical line that starts on the servo sleeve and ends on the housing, see figure 7. These marks will indicate how far to screw the servo sleeves in during reassembly.

**26** Remove the servo sleeves.

**27** Remove two o-rings from each servo sleeve.

## Hydrostatic Variable Pump Repairs

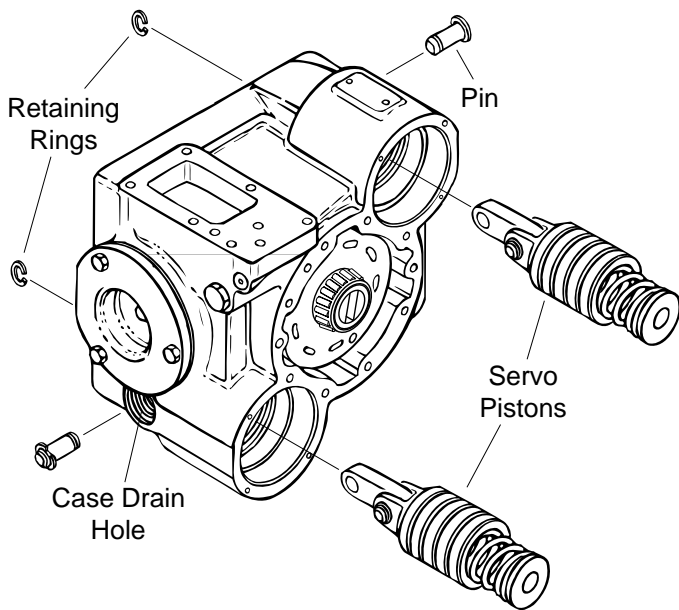

Figure 9

**34** Remove the inside retaining ring from each of the pins that connect the servo piston links to the swashplate. Slide the pins out through the case drain holes and remove the servo pistons, see figure 9.

**Note:** Disassembly of the servo pistons is not required unless they are damaged.

**35** Mark the pump housing and the trunnions so they can be reinstalled in the same locations.

**36** Repeat the following steps to remove each trunnion:

Remove the three hex head bolts that hold the trunnion to the pump

The trunnion fits into the pump tightly; use a slide hammer to loosen it. Screw the slide hammer into the threaded hole in the trunnion. The sizes of the threaded trunnion holes are listed below:

Model Number	Screw Size
33, 39, 46	3/8-16
54, 64	7/16-14

Remove the trunnions and shims.

**Important:** Keep the shims with each trunnion; they must be reinstalled on the same trunnion during reassembly. The shims pre-load the trunnion bearings.

Remove the o-ring from the trunnion, see figure 10.

**37** If the trunnion bearings are damaged replace them. A split blade bearing puller will be needed to remove the bearing cone from the trunnion. Use a press to install the new bearing cone.

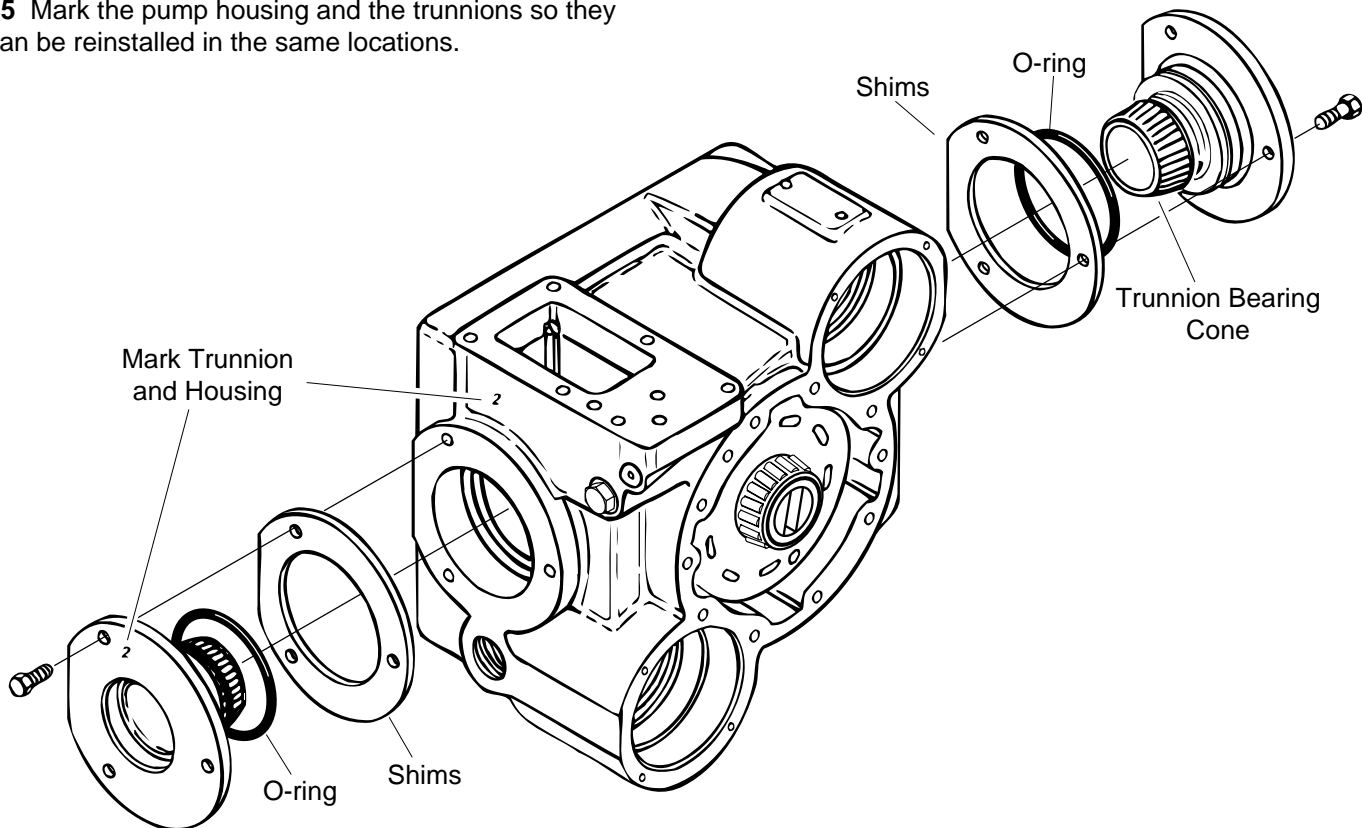

Figure 10

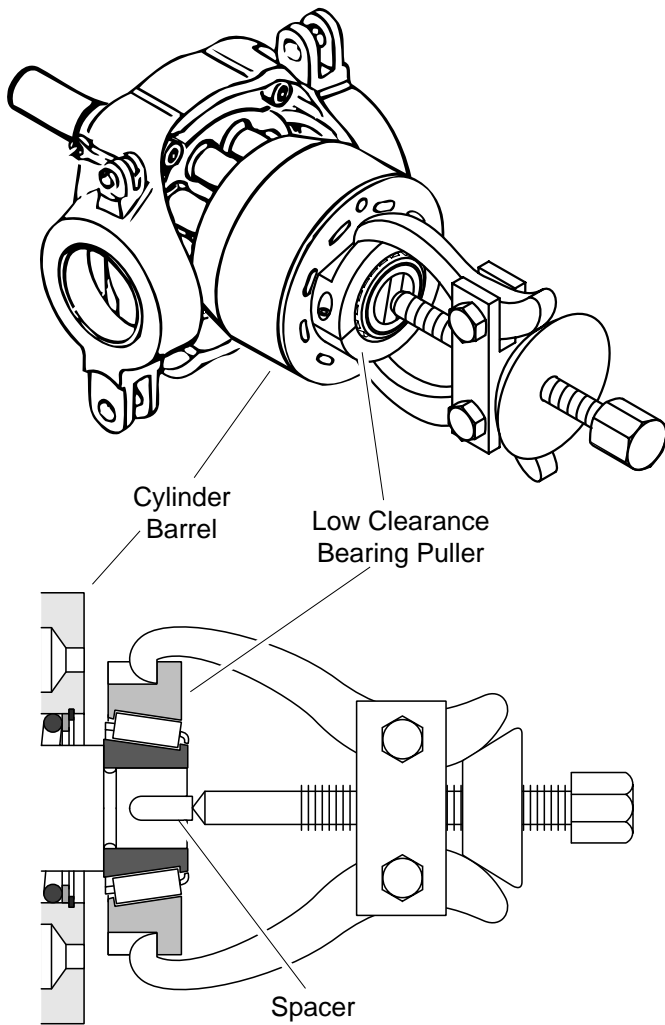

Figure 11

**38** Carefully remove the swashplate, cylinder barrel and shaft through the mounting flange end of the housing.

**39** Pull the end cover bearing cone from the shaft. Use a special low clearance bearing puller and place a spacer in the slot in the shaft.

**Note:** Detailed drawings of the low clearance bearing puller and spacer are given in Appendix E. The low clearance bearing puller was designed to protect the cylinder barrel face, see cut-away in figure 11. The spacer will prevent the slotted end of the shaft from spreading.

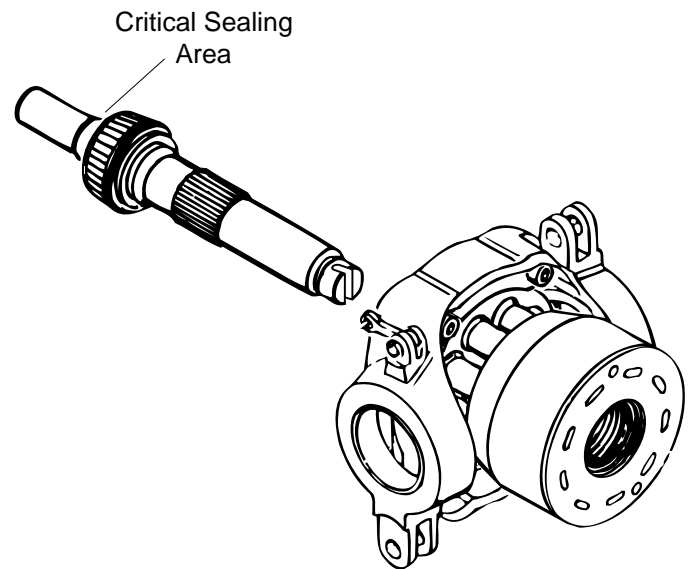

Figure 12

**40** Remove the shaft and bearing assembly from the swashplate and cylinder barrel. Keep the cylinder barrel and pistons together.

**Note:** Do not remove the bearing cone from the shaft unless it is damaged. Go to step 43 if the bearing cone is undamaged.

**41** Press the old bearing cone from the shaft.

**Caution:** Do not damage the sealing area of the shaft, see figure 12. The shaft sealing area is between the bearing journal and the keyway or splined end of the shaft. This area is extremely critical.

**42** Press the new bearing cone onto the shaft. Use the special stop limit tool shown in Appendix E of this manual. The position of the bearing cone on the shaft is important.

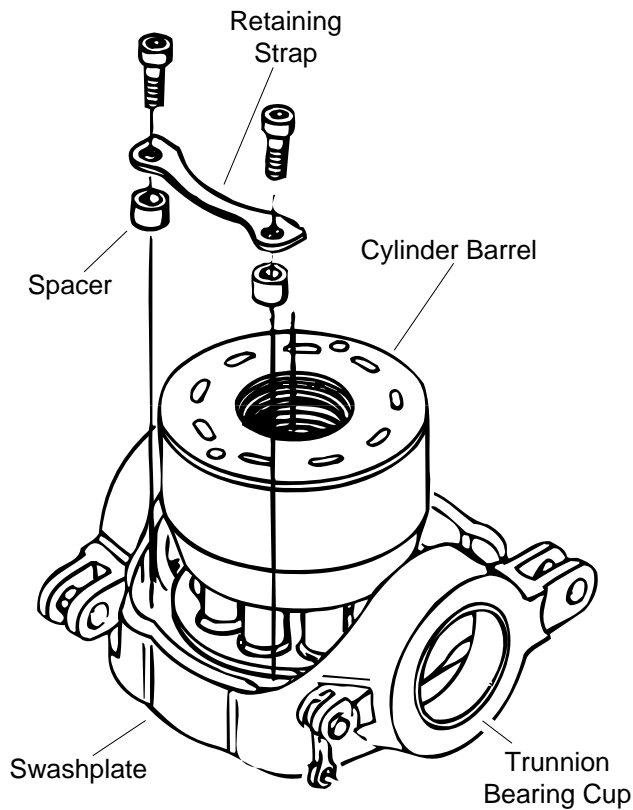

Figure 13

**43** Set the swashplate and cylinder barrel assembly on one of the trunnions; in this position it will be easier to break the retaining strap bolts loose. Remove one of the retaining straps and loosen the other.

**Important:** keep the cylinder barrel and pistons together.

**44** Reposition the swashplate and cylinder barrel assembly so the cylinder barrel is on the bottom. Remove the swashplate by lifting it slightly and sliding it over to disengage the retaining strap.

**45** Remove the retaining strap and thrust plate from the swashplate.

**46** Replace the trunnion bearing cups if they are damaged. Use a long punch to remove the old bearing cups, then carefully press the new bearing cups into the swashplate.

## Reassembly

Inspect the cylinder barrel, pistons, piston slippers, and thrust plate. Replace any worn or damaged parts. Check all mating surfaces; replace any parts with scratches or burrs that could cause leakage. Inspect parts for excessive wear and replace as necessary. Wash all metal parts in clean solvent and blow them dry with compressed air. Do not wipe parts dry with paper towels or cloth. Lint in a hydraulic system will cause damage.

Always use new seals when reassembling hydraulic pumps. Refer to parts list 6-608 for seal part numbers, replacement parts, and ordering information.

**Important:** During reassembly lubricate the new rubber seals with a petroleum jelly like Vaseline. Also lubricate all machined surfaces and bearings with clean hydraulic fluid.

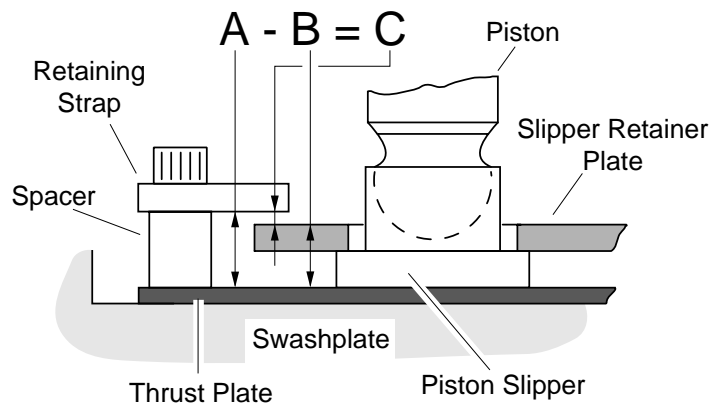

Figure 14

**47** Before beginning reassembly check the piston slipper clearance:

First, use a vernier calipers to measure the spacer height, height "A" in figure 14.

Next, measure the thickness of the slipper retainer plate and piston slippers, Thickness "B" in the figure.

Finally, calculate the piston slipper clearance "C" by subtracting thickness "B" from height "A".

**Clearance "C" must not exceed .008 in. [,20 mm].**

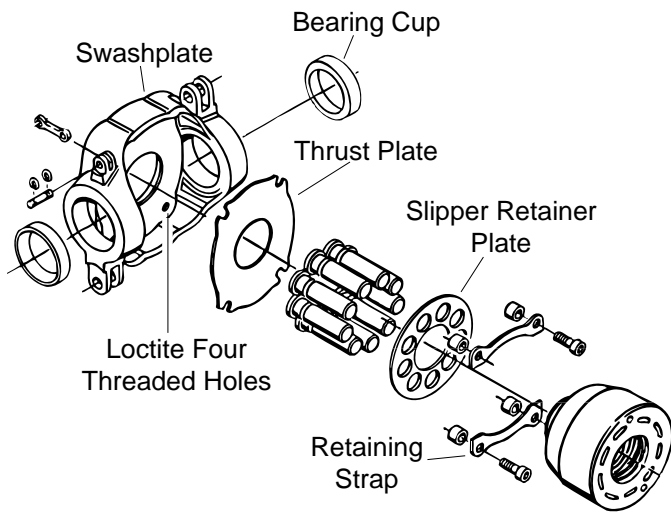

Figure 15

**48** Position the cylinder barrel, pistons, and slipper retainer so the piston slippers are on top.

**49** Apply two drops of Loctite 271 in each of the four retaining strap holes in the swashplate. Apply the Loctite no closer than two threads from the running surface. Do not apply Loctite to the retaining strap bolts.

**Caution:** Remove all excess Loctite, it will contaminate the pump if not removed.

**50** Place the thrust plate in the swashplate.

**51** Install one of the retaining straps, and leave the bolts loose.

**52** Apply a light coating of clean hydraulic fluid to the thrust plate.

**53** Fit the swashplate onto the cylinder barrel assembly. Be sure the slipper retainer plate is between the swashplate and retaining strap.

**54** Turn the swashplate and cylinder barrel over so the swashplate is on the bottom.

**55** Install the second retaining strap and tighten all four retaining strap bolts to 18 lb-ft [25 Nm]. Remove all excess Loctite.

**56** Liberally lubricate the pistons slippers, thrust plate, retainer plate, pistons, and cylinders. These parts must have sufficient start-up lubrication.

**57** Slide the shaft and bearing assembly through the swashplate into the cylinder barrel.

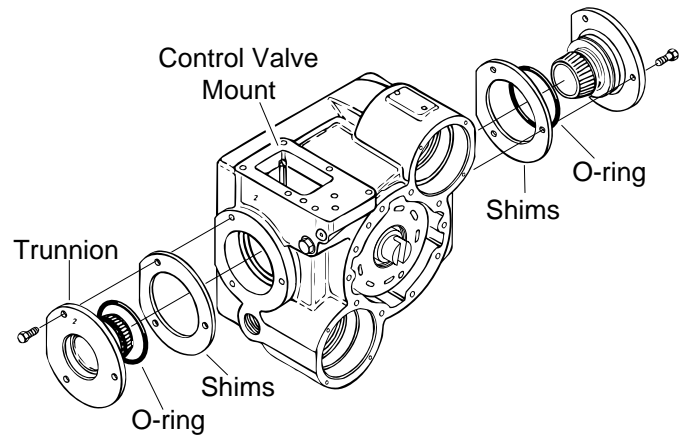

Figure 16

**58** Carefully, put the swashplate, cylinder barrel, and shaft into the pump housing. Be sure the feedback linkage is by the control valve mount.

**59** Lubricate and install a new o-ring on each trunnion.

**60** Install the trunnions and shims in their original locations.

**61** Install the trunnion bolts and tighten them to the specified torque given below:

Model Number	Trunnion Bolt Torque
33, 39, 46	28 lb-ft [38 Nm]
54, 64	44 lb-ft [60 Nm]

## Hydrostatic Variable Pump Repairs

**62** After the bolts are torqued strike one of the trunnions to free up the swashplate's movement.

**63** Measure the swashplate breakaway force with a spring compression scale. Attach the scale to the feedback linkage as shown in figure 17. A swashplate breakaway force of 2 to 5 lb [0,9 to 2,3 Kg] is required. Add or subtract trunnion shims as needed.

**Important:** The trunnion shims on each side of the pump should be equal thickness. The maximum allowable difference between the sides is .010 in. [0,3 mm].

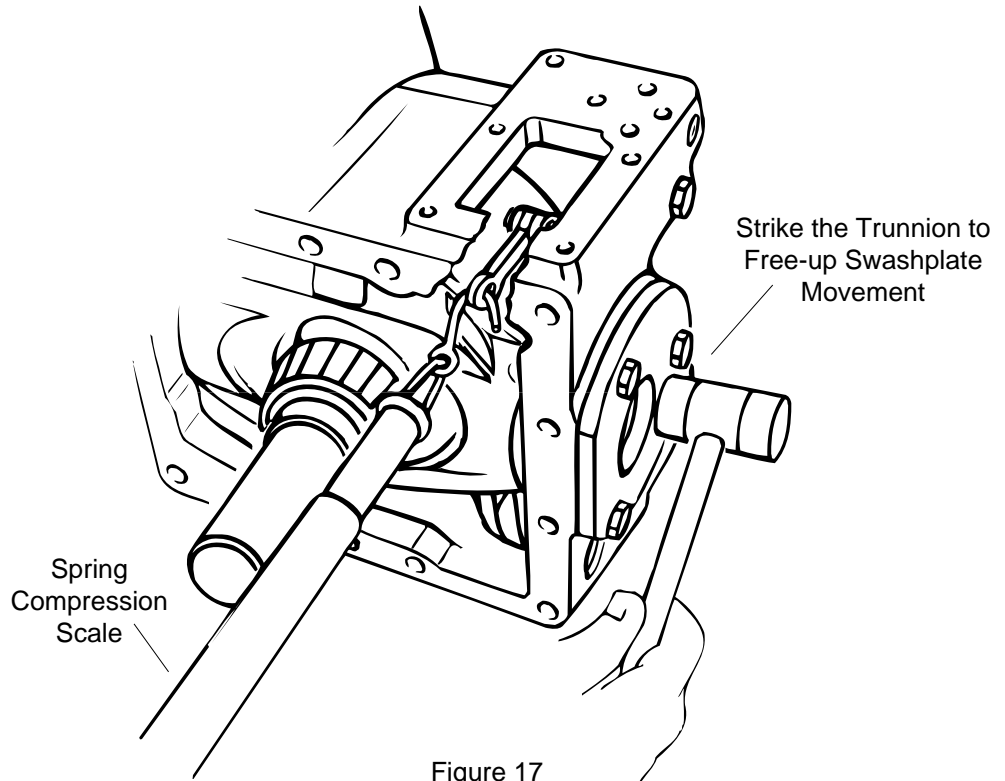

Figure 17

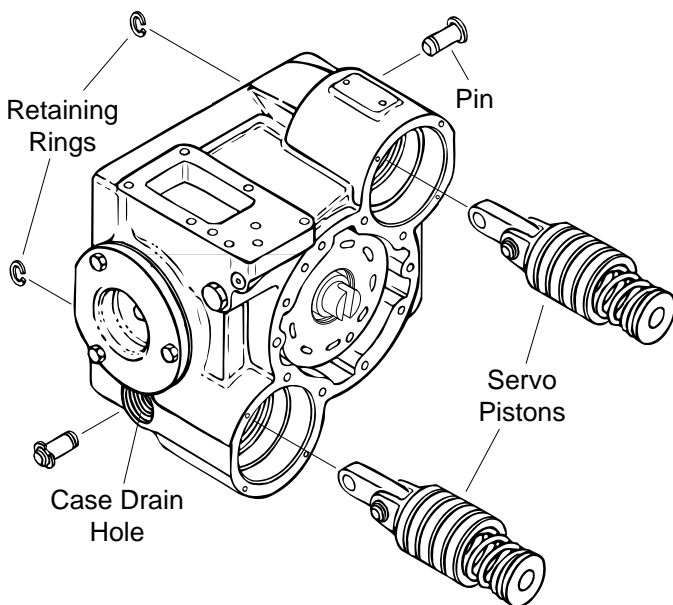

Figure 18

**64** Install the servo pistons. Line up the servo piston links and install the pins through the case drain holes as shown in figure 18.

**65** Carefully remove the shaft and bearing assembly. Reposition the pump so it is sitting on the mounting flange gasket surface.

**Note:** Do not let the cylinder barrel slide off of the pistons.

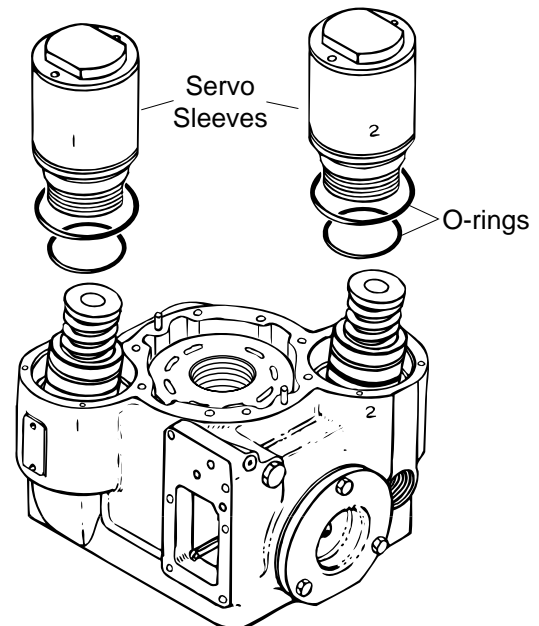

Figure 19

**66** Lubricate and install new o-rings on the servo sleeves.

**67** Install each servo sleeve in its original location. Start by lifting one of the servo pistons, tilting the swashplate to its maximum angle, then carefully fit the servo sleeve over the piston. Next, lower the servo sleeve and piston into the pump housing until the threads meet. Finally, screw the servo sleeve in until the scribe marks line up. Repeat this procedure for the second servo sleeve.

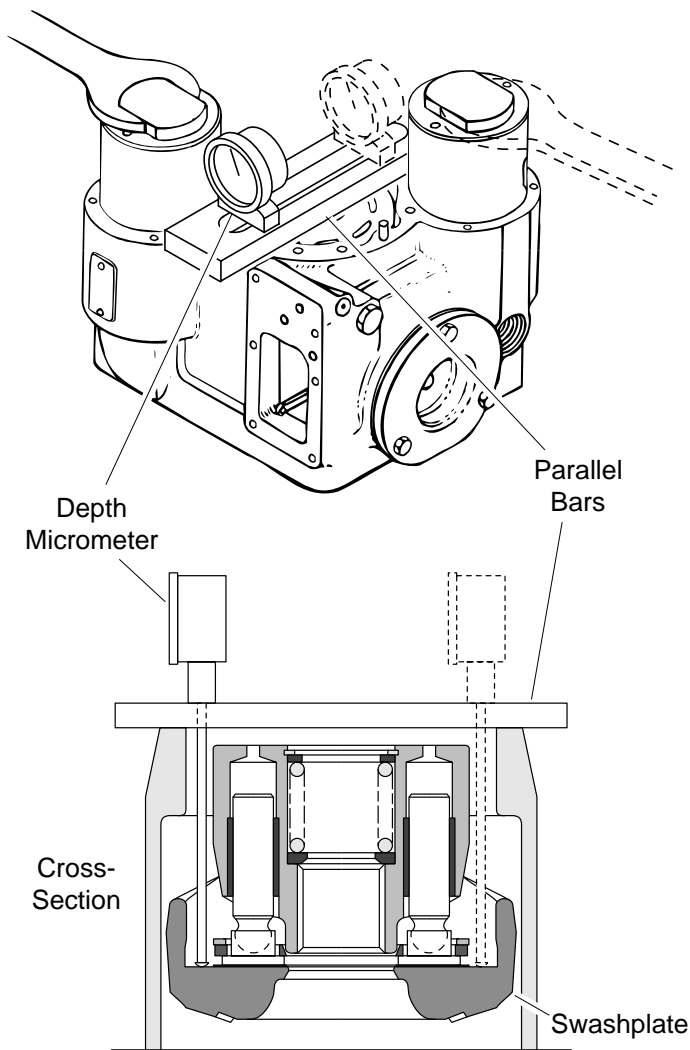

Figure 20

**68** Check the zero angle of the swashplate.

**Important:** Zeroing the swashplate insures that the springs on the servo pistons will return the swashplate to neutral when the control lever is centered.

**69** Place parallel bars across the end cover gasket surface and measure the depth to the swashplate on each side of the cylinder barrel, as shown in figure 20.

**The maximum allowable difference in the measurements is .0005 inch [.012 mm].**

**The springs on the servo pistons must hold the swashplate tight; The maximum allowable swashplate rock is .001 inch [.03 mm].**

Screw the servo sleeves in or out to adjust the zero angle of the swashplate.

**70** Install the servo sleeve retainers and re-stake if necessary.

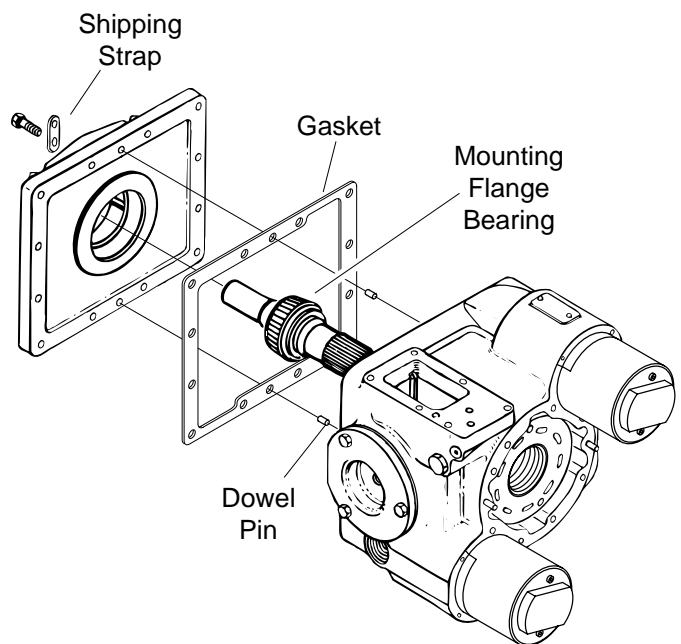

Figure 21

**71** Reposition the pump so the control valve mount is on top. Be careful do not let the cylinder barrel slide out off the pump.

**72** Carefully slide the shaft and bearing assembly into the pump.

**73** Install two dowel pins in the holes in the mounting flange surface of the pump housing.

**74** Place a new mounting flange gasket on the pump housing. Hold it in place with petroleum jelly.

**75** Lubricate the mounting flange bearing with clean hydraulic fluid

**76** Install the mounting flange on the pump.

**77** Install the twelve mounting flange bolts. Remember to install the shipping strap. Tighten the bolts to the torque specified in the table below:

Model Number	Mounting Flange Bolt Torque
33, 39, 46	28 lb-ft [38 Nm]
54, 64	44 lb-ft [60 Nm]

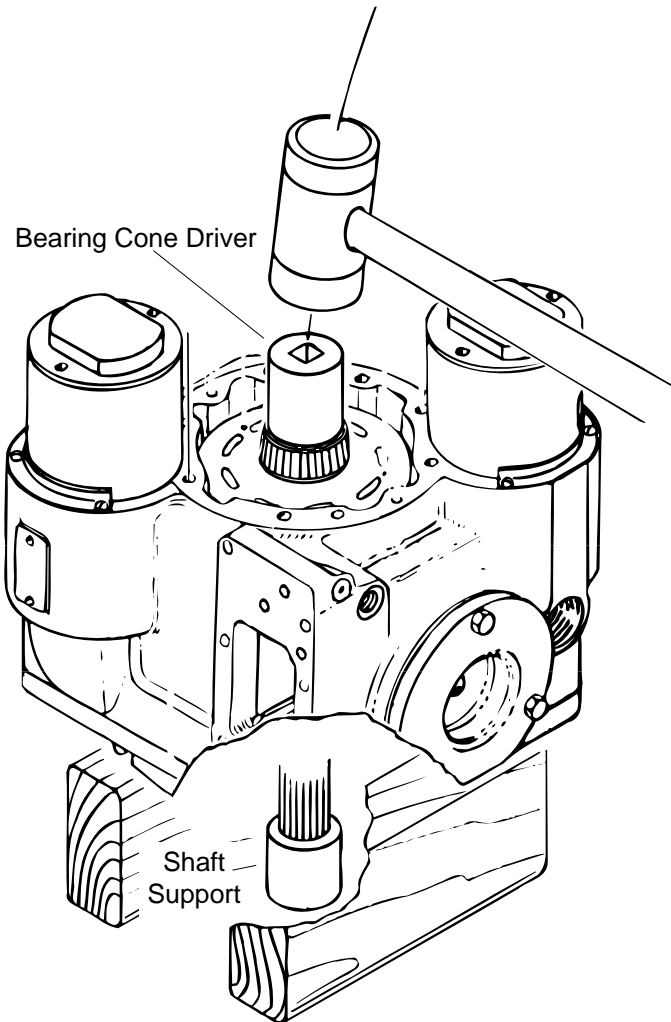

Figure 22

**78** Turn the pump over so the shaft is vertical and the mounting flange is down.

**79** Support the pump's shaft and use a bearing driver to install the end cover bearing cone, see figure 22. Be sure the bearing cone is seated against the shoulder of the shaft.

**Note:** A detailed drawing of the bearing cone driver is shown in Appendix E of this manual.

**80** Remove the shaft support.

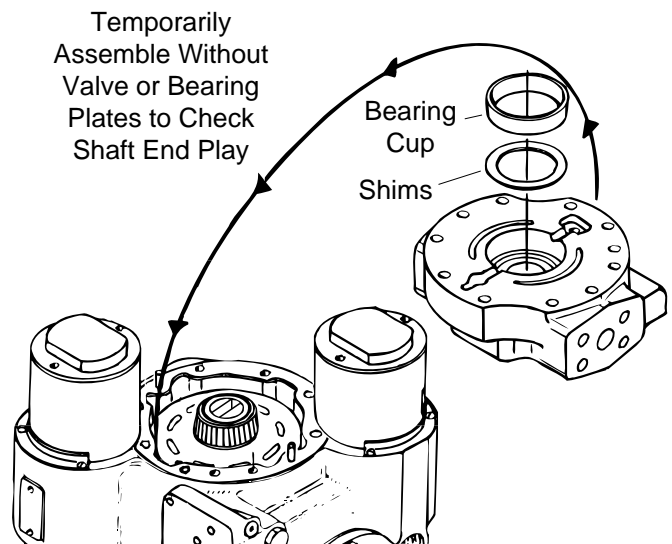

Figure 23

**81** Install two dowel pins in the holes in the end cover surface of the pump housing.

**82** Install a new end cover gasket.

**83** Check the pump shaft end play before installing the bearing and valve plates.

Be sure the bearing cup and shims are in the end cover and place it on the pump.

Install the eight end cover bolts and tighten them alternately to the torque specified in the table below:

Model Number	End Cover Bolt Torque
33, 39, 46	39 lb-ft [53 Nm]
54, 64	63 lb-ft [85 Nm]

Turn the pump over so the mounting flange and shaft are on top. Place a block of wood under the end cover so the weight of the pump is not on the servo sleeves.



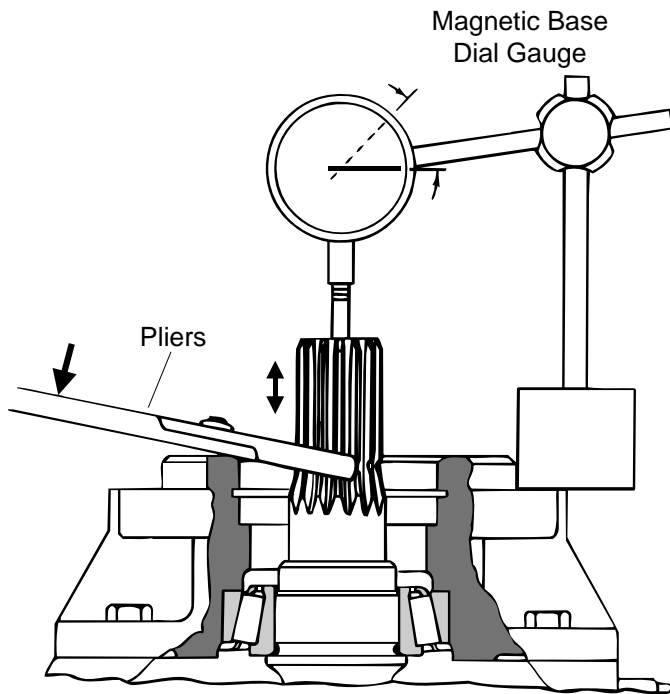

Figure 24

Gently tap the shaft into the pump with a plastic hammer to seat the bearings.

Place a dial gauge, with a magnetic base over the shaft as shown in figure 24. Grasp the shaft low with a pliers and pry it up to get the end play reading.

**The pump shaft end play must be from .002 in. to .007 in. [.05 mm to .17 mm].**

Adjust the end play by adding or subtracting shims from under the end cover bearing cup.

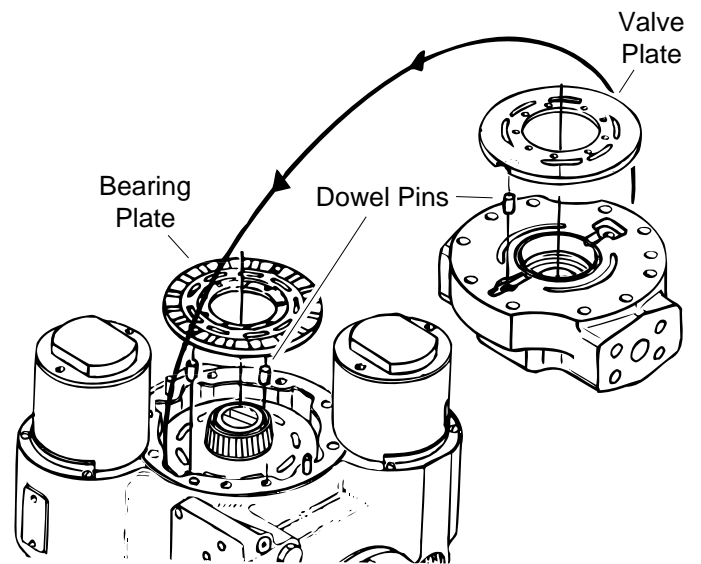

Figure 25

**84** Turn the pump over and remove the end cover.

**85** Install two dowel pins in the holes in the cylinder barrel face.

**86** Place the bearing plate on the cylinder barrel and engage it with the dowel pins.

**87** Liberally lubricate the bronze surface of the bearing plate with clean hydraulic fluid.

**88** Install a dowel pin in the hole in the end cover.

**89** Place the valve plate on the end cover. Be sure it engages with the dowel pin.

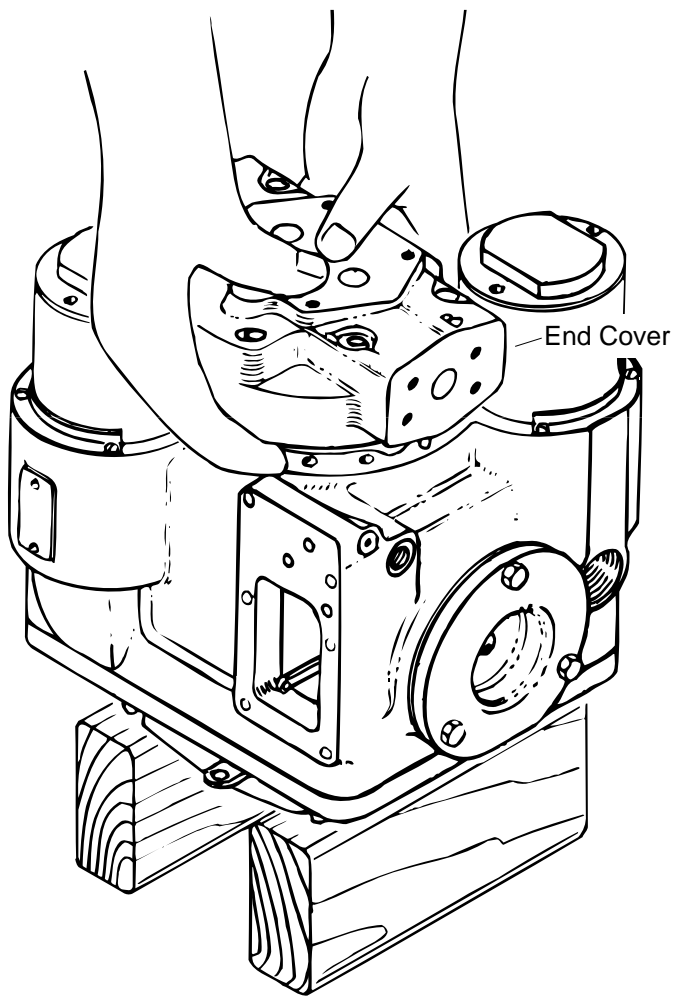

Figure 26

**90** Holding the valve plate in place carefully install the end cover.

**Note:** Use petroleum jelly to help hold the valve plate to the end cover.

**91** Install the eight end cover bolts, remember the shipping strap.

**92** Tighten the end cover bolts evenly so the cylinder barrel spring pre-load is taken-up gradually. Torque them alternately to the specifications given in the table below:

Model Number	End Cover Bolt Torque
33, 39, 46	39 lb-ft [53 Nm]
54, 64	63 lb-ft [85 Nm]

**93** Lubricate and install new o-rings and back-up rings on the check valves. The back-up ring must be installed on the charge pump side of the o-ring, see figure 27.

**94** Install the check valves in the pump end cover. Push them down until their tops are flush with the surface of the end cover.

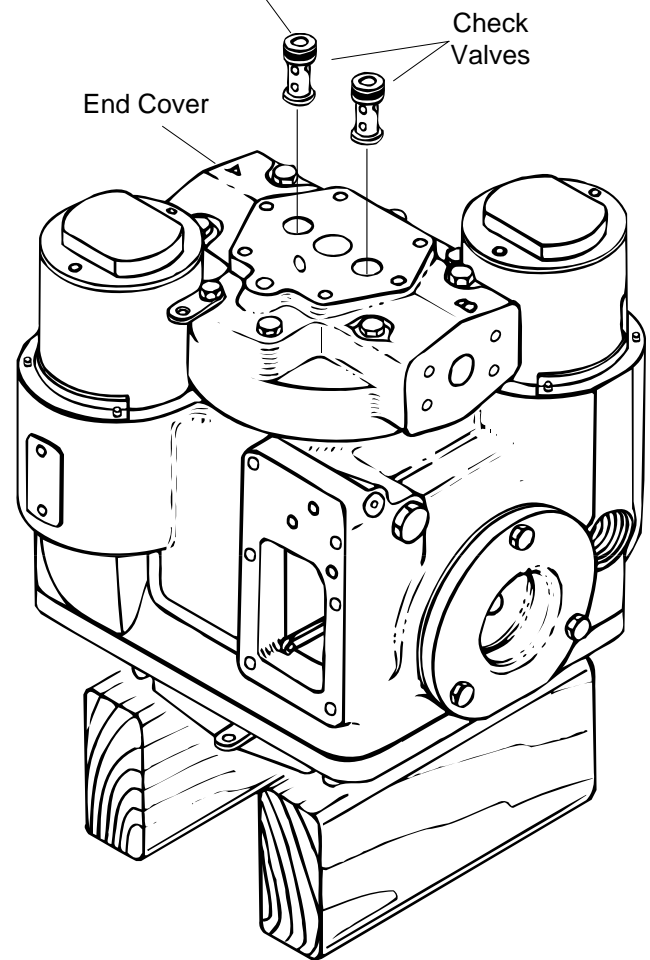
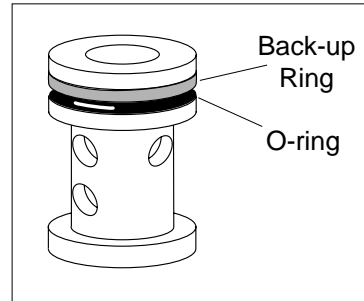

Figure 27

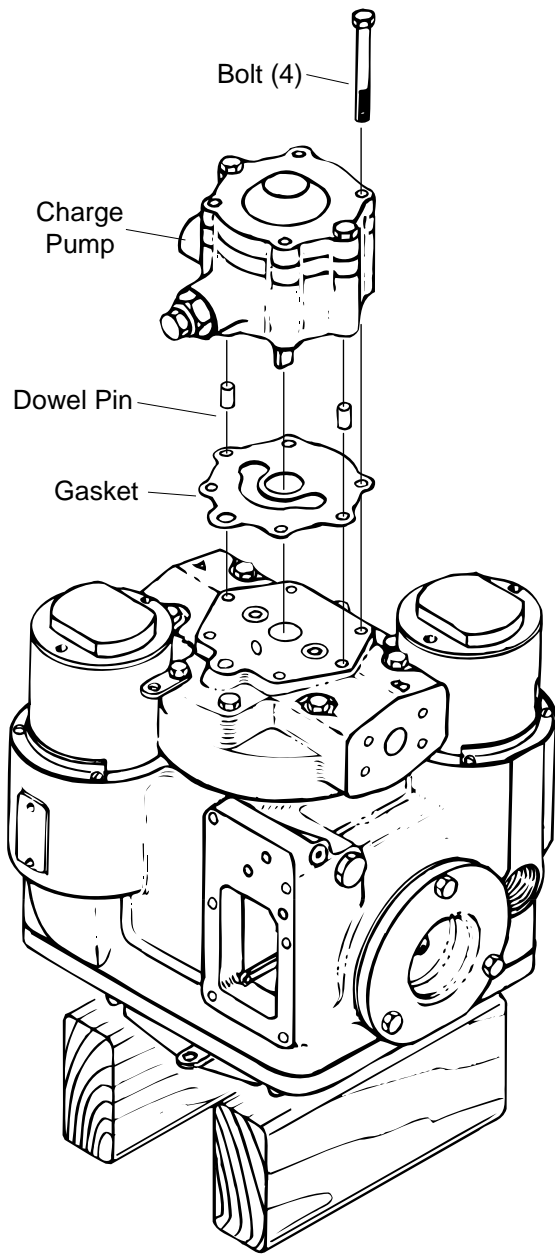

Figure 28

**95** Install the two remaining dowel pins in the holes in the end cover, see figure 28.

**96** Place a new charge pump gasket on the end cover.

**97** Rotate the charge pump shaft so the tang and the dowel pin holes line-up correctly with the pump. Then carefully install the charge pump.

**Note:** Some charge pumps have splined drives.

**98** Install the four hex head bolts that hold the charge pump to the pump end cover. Torque them alternately to 25 lb-ft [34Nm]. Charge pumps that have 'A' or 'B' pads require a torque of 22 lb-ft [30 Nm].

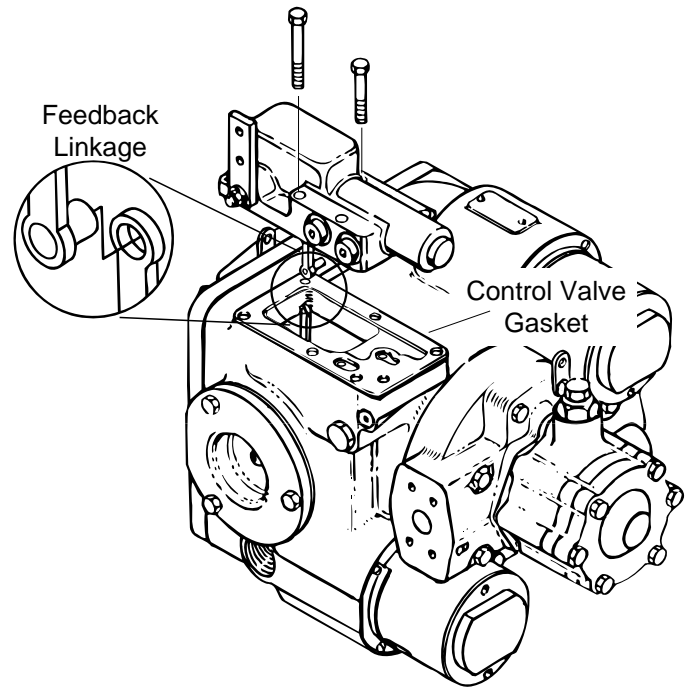

Figure 29

**99** Reposition the pump so the control valve mount is on top.

**100** Place a new control valve gasket on the pump.

**101** Connect the feedback linkage and position the control valve on the pump.

**Important:** When the control valve is positioned on the pump make sure the feedback linkage points towards the end cover.

**102** Install the six hex head bolts and tighten them finger tight.

**103** Move the control lever back and forth; it should move freely in both directions and self-center. If it doesn't recheck the feedback linkage.

**104** Tighten the six hex head bolts to 16 lb-ft [22 Nm].

## Hydrostatic Variable Pump Repairs

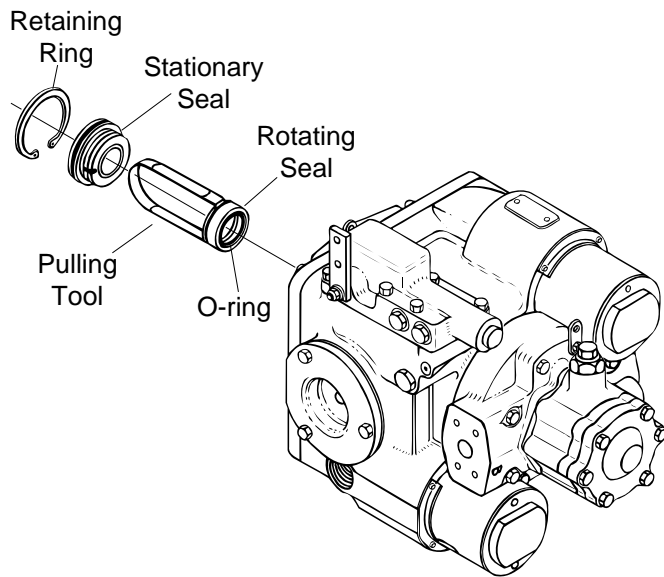

Figure 30

**105** Reposition the pump so the shaft seal can be installed.

**Note:** Eaton recommends replacing the entire shaft seal. Use Shaft Seal Kit P/N 990231.

**Important:** The metal-to-metal sealing surfaces are critical. Clean the areas of contact with a suitable solvent then blow them dry. The solvent must evaporate without leaving a residue. Do not touch the sealing surfaces after cleaning.

**106** Apply petroleum jelly to the o-ring and install it in the rotating seal

**107** Apply a light coating of clean hydraulic oil to the cleaned metal sealing surface of the rotating seal.

**108** Install the rotating seal using the special pulling tool (CAS 1844).

**109** Screw a 3 in. X 1/4-20 bolt into the threaded hole in the new stationary seal. The bolt provides a convenient means for holding the seal.

**110** Apply petroleum jelly to the o-ring that is around the largest part of the stationary seal.

**111** Apply a light coating of clean hydraulic oil to the cleaned metal sealing surface of the stationary seal.

**112** Install the stationary seal.

**113** Using the retaining ring pliers install the retaining ring with the beveled side out, be sure that it is seated properly.

**Caution: Verifying the accuracy of repairs on an authorized test stand is essential.**

## Appendix A: IPOR End Cover

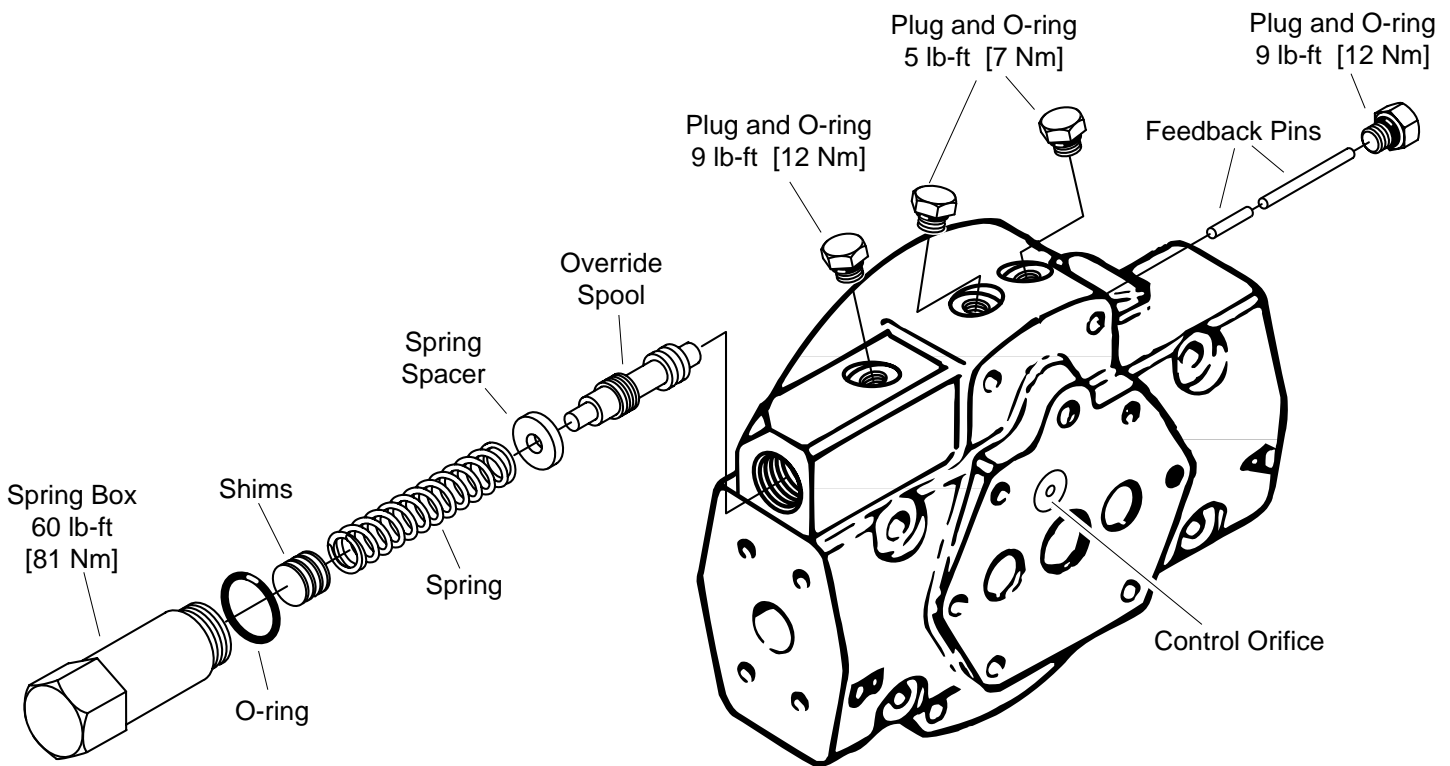

Figure 31

After the end cover has been removed from the pump, disassemble it as shown in figure 31.

Flush the end cover's internal passages and wash the IPOR parts with clean solvent. Blow the parts dry with compressed air.

Inspect the parts and replace any that are worn or damaged.

Inspect the control orifice, see figure 31, if it is plugged after flushing replace it.

To remove the plugged orifice, strike it in the center with a center punch. This will curl the orifice so it can be removed.

Install a new orifice of the same size. The orifice size is stamped on the orifice in thousandths of an inch, example: 57 = .057 in.

Place the orifice in the orifice pocket so the size is visible.

Stake the orifice in six places with a center punch.

Insure that the orifice is properly seated after staking.

**Important:** Do not flatten and reuse orifices.

Reassemble the end cover. Install new o-rings and torque the plugs and spring box to the specifications given in figure 31.

### IPOR Pressure Setting

The IPOR pressure setting is adjusted by adding or removing shims. An .018 inch shim changes the pressure override setting by 500 psi. Shims totaling .125 inch will provide an override setting of approximately 5000 psi. Because of tolerances the actual pressure override must be measured with a gauge while the pump is operating.

Appendix B: Power Limiter Valve End Cover

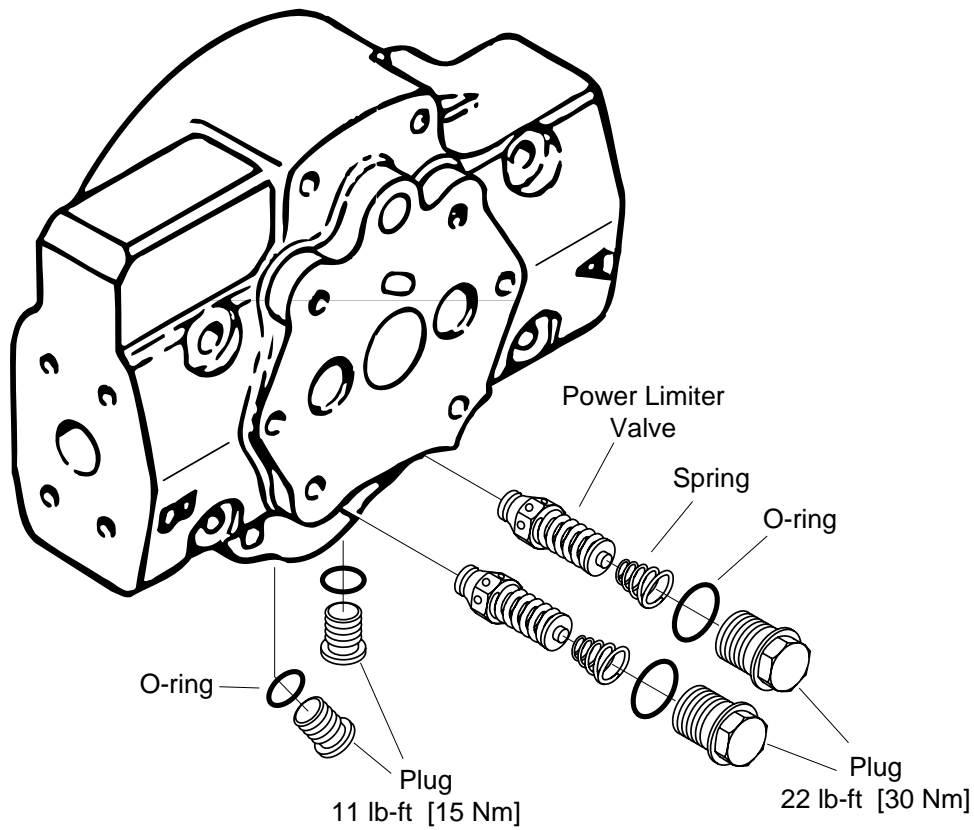

Figure 32

After the end cover has been removed from the pump, disassemble it as shown in figure 32.

Flush the end cover's internal passages and wash the power limiter parts with clean solvent. Blow the parts dry with compressed air.

Inspect the parts and replace any that are worn or damaged.

Reassemble the end cover. Install new o-rings and torque the plugs to the specifications given in figure 32.

**Power Limiter Valve Pressure Setting**

The pressure setting is stamped on the power limiter valve. If there is a two digit code find the pressure setting in the table. If the power limiter valve has a three digit number, multiply the number by 10 to get the pressure setting, example: 550 = 5500 psi.

Power Limiter Valve Settings	
2 Digit Code	Pressure Setting (psi)
54	4000
59	4500
56	5000
63	5500
21	5800
57	6000

## Appendix C: Control Orifice Installation and Removal

There are two types of control valve orifices: the plate orifice and the plug orifice.

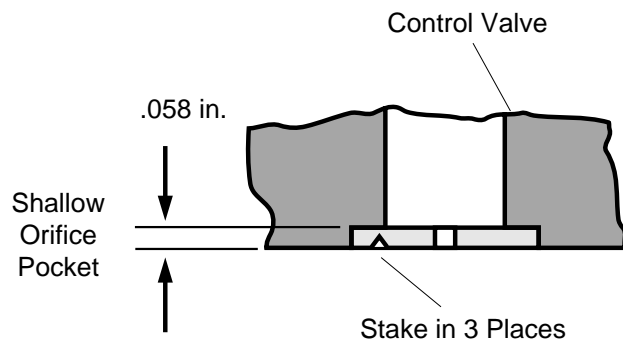

**Plate Orifice**

The plate orifice is used in control valves that have shallow orifice pockets.

The orifice size is stamped on the orifice in thousandths of an inch, example: 57 = .057 in.

### Installation:

Place the orifice in the orifice pocket so the size is visible.

Stake the orifice in three places with a center punch.

Insure that the orifice is properly seated after staking.

### Removal:

To remove the plate orifice, strike it in the center with a center punch. This will curl the orifice so it can be removed.

**Important:** Do not flatten and reuse orifices.

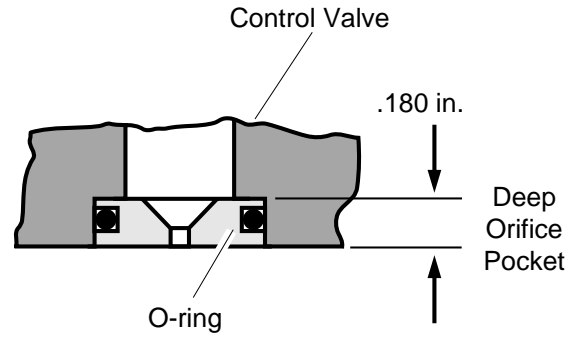

**Plug Orifice**

The plug orifice is used in control valves that have deep orifice pockets. The plug orifice replaces the hat orifice.

### Installation:

Before installing the plug orifice be sure that the o-ring is in place. Apply petroleum jelly to the edge of plug orifice and o-ring.

Carefully insert the plug orifice into the orifice pocket. The large opening in the plug must go into the control valve.

### Removal:

To remove the plug orifice, insert a stiff wire, that has been bent to form a hook, through the orifice hole. Hook the inside of the plug orifice and pull it out of the pocket.

**Important:** Removing the orifice may damage it, so do not reuse orifices.

Appendix D: Charge Pump Repair

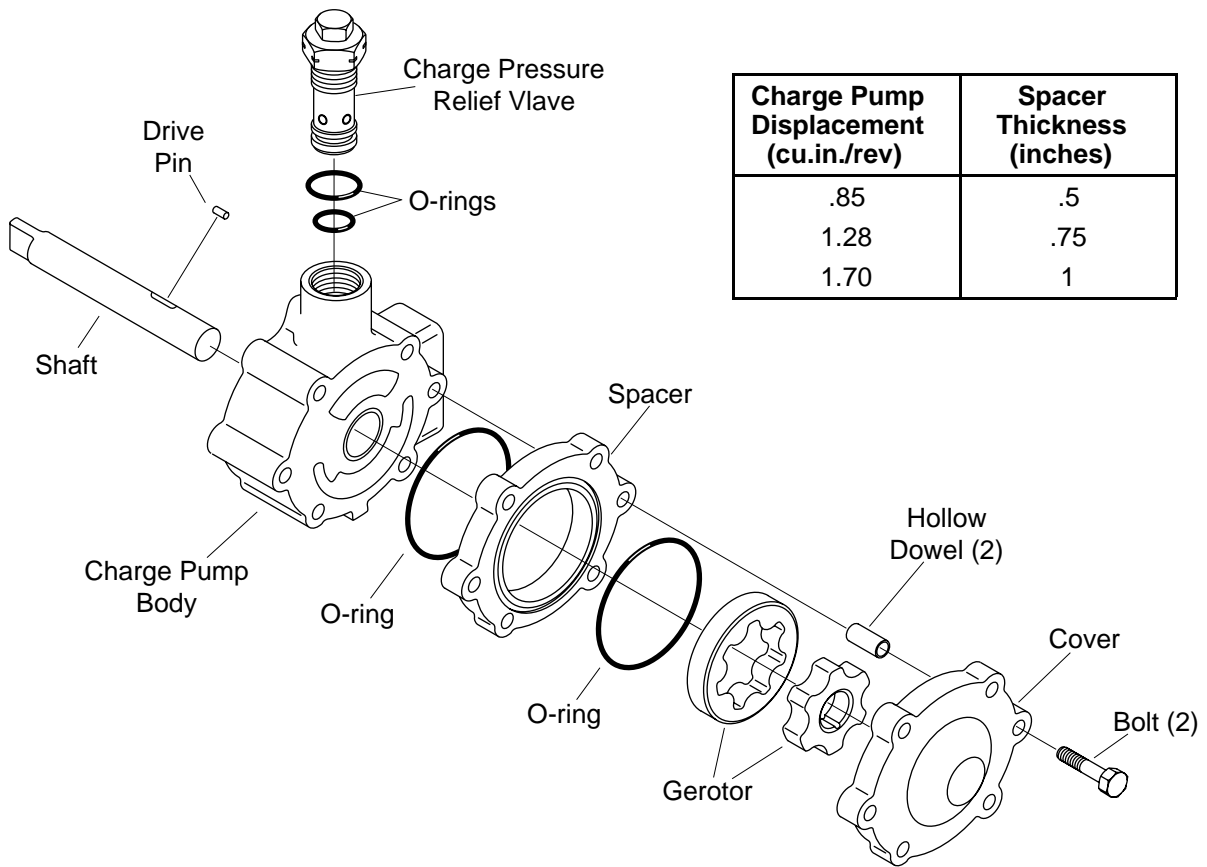

Figure 33

Disassemble the charge pump by removing the two bolts that hold it together, as shown in figure 33.

**Note:** Figures 33 and 34 show a standard charge pump. The repair procedures given here apply to optional charge pumps too.

Wash the parts in clean solvent and blow them dry with compressed air.

Inspect the parts and replace any that are worn or damaged.

The three digit number stamped on the charge pressure relief valve indicates its pressure setting. Multiply this number by ten to get the pressure setting in PSI. Example: 022 = 220 PSI.

Assemble the charge pump using new o-rings. Lubricate the o-rings with petroleum jelly before assembly. Apply a coating of clean hydraulic fluid to the gerotor to provide start up lubrication.

Tighten the two bolts that hold the charge pump together to 17 lb-ft [23 Nm]. Tighten the charge pressure relief valve to 80 lb-ft [108 Nm].

**Important:** The charge pump’s rotation direction must match the rotation direction of the pump.

The charge pump’s rotation direction can be identified by checking the alignment of the beads on the pump body and spacer. Figure 34 summarizes charge pump rotation identification.

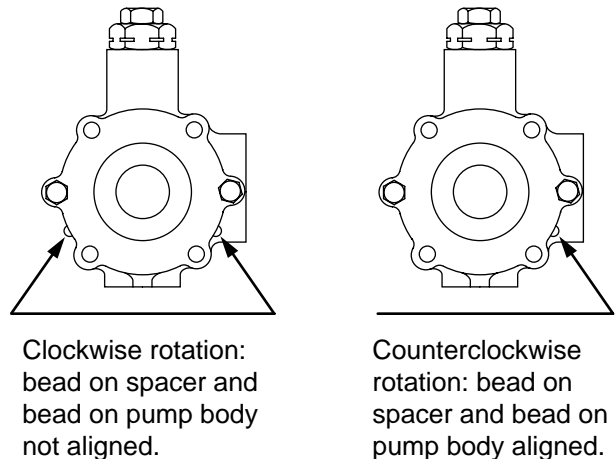

Figure 34



## Appendix E: Special Tools

(All dimensions are given in inches.)

### Bearing Cone Drive

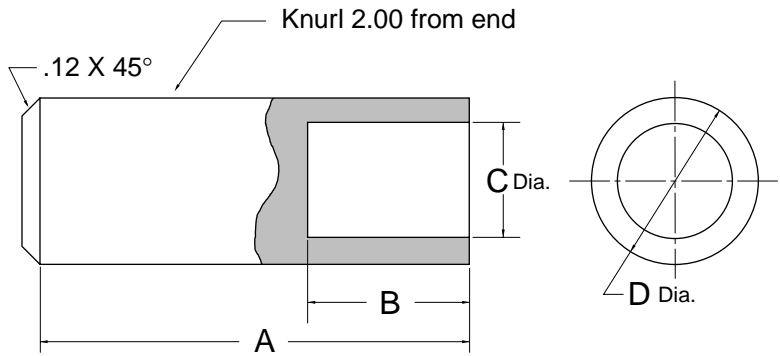

Model	A	B	C	D
33, 39, 46	4.0	1.5	1.01	1.25
54, 64	4.0	1.5	1.25	1.48

Material / Heat Treatment; C.R.S. / 50-55 Rc

### Check Valve Puller

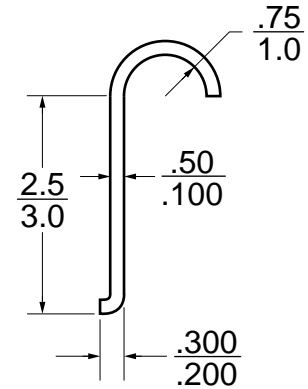

Material - Steel

### Low Clearance Bearing Puller

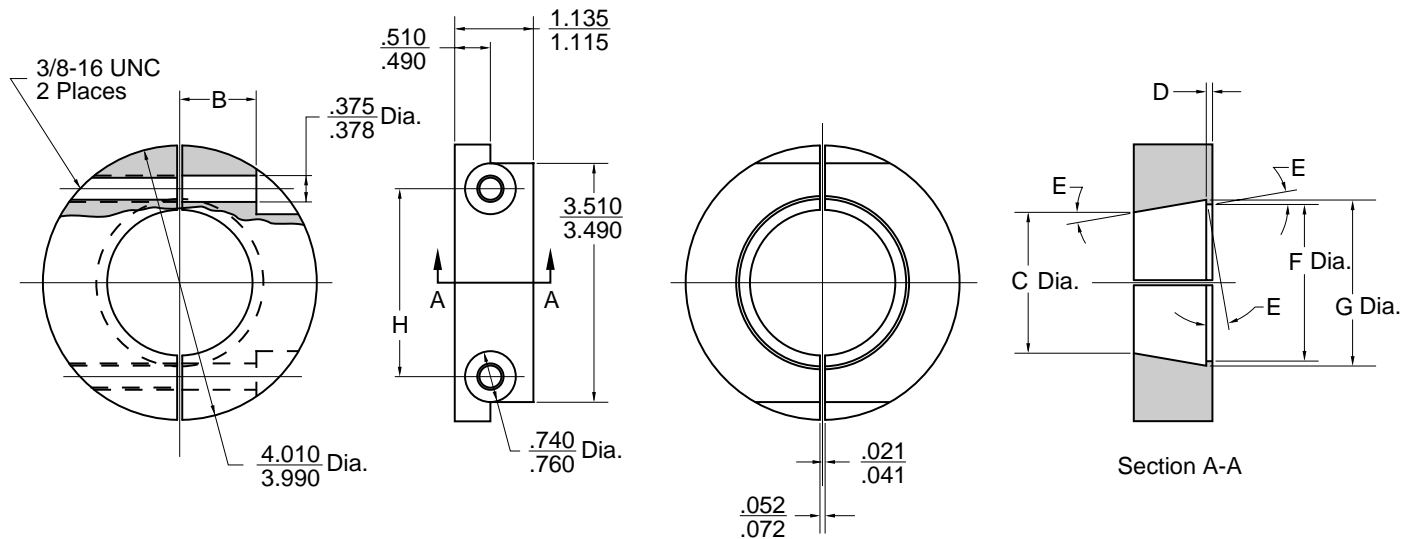

Model	B	C	D	E	F	G	H
33, 39, 46	$\frac{1.050}{1.070}$	1.565 Ref.	$\frac{1.35}{1.29}$	13°	$\frac{1.907}{1.913}$	$\frac{2.020}{2.026}$	$\frac{2.622}{2.628}$
54, 64	$\frac{1.115}{1.135}$	1.603 Ref.	$\frac{.141}{.135}$	20°	$\frac{2.223}{2.229}$	$\frac{2.318}{2.324}$	$\frac{2.747}{2.753}$

Material / Heat Treatment; Stentor / 45-55 Rc

# Hydrostatic Variable Pump Repairs

## Stop Limit Tool

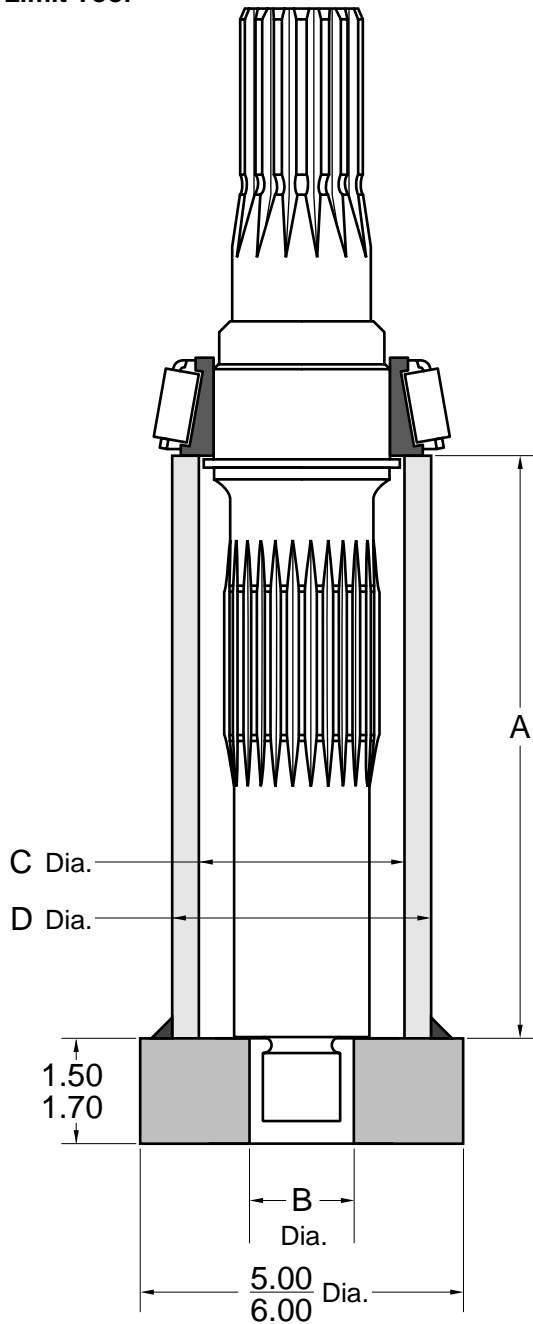

	Model	
	33, 39, 46,	54, 64
<b>A</b> ±.001	5.803	6.682
<b>B</b>	$\frac{1.00}{1.20}$	$\frac{1.30}{1.32}$
<b>C</b>	$\frac{2.20}{2.30}$	$\frac{2.20}{2.30}$
<b>D</b>	3.00 min.	3.00 min.

Material - Steel

## Shaft End Spacer

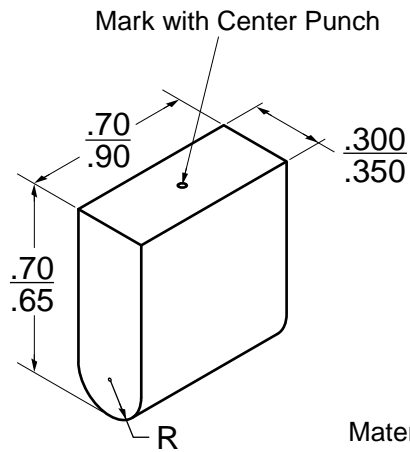

Material - Steel

## Rotating Seal Puller

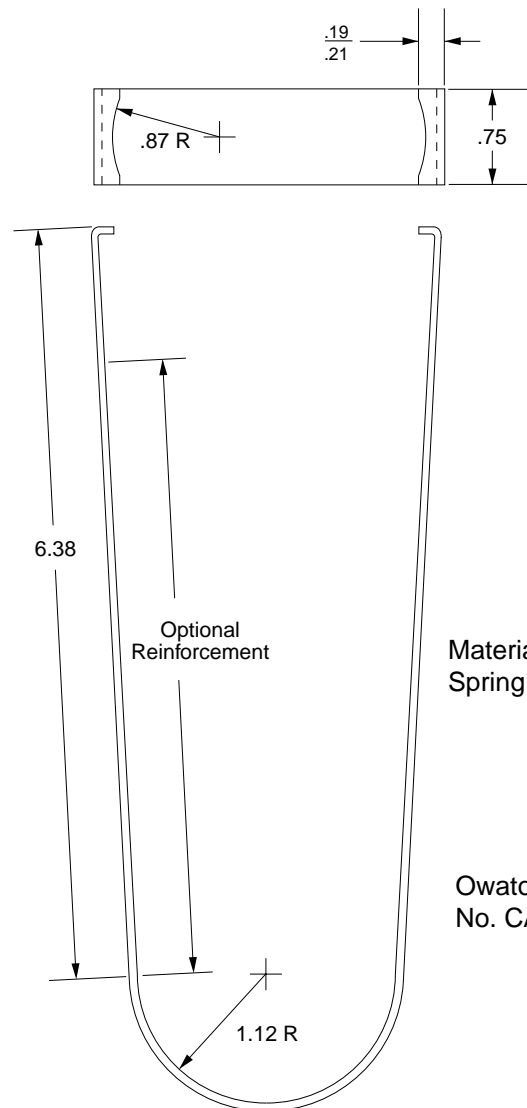

Material; SAE 1074 Spring Steel 16 Ga.

Owatonna Tool Co.  
No. CAS 1844

## Hydraulic Fluid Recommendations

A reputable supplier can help you make the best selection of hydraulic fluid for use in Eaton hydrostatic products.

For satisfactory operation the following recommendations apply:

1. The filter system used in the hydraulic circuit should be capable of cleaning and maintaining the hydraulic fluid to meet ISO Cleanliness Code 18/13 per SAE J1165. This code allows a maximum of 2500 particles per milliliter greater than 5  $\mu\text{m}$  and a maximum of 80 particles per milliliter greater than 15  $\mu\text{m}$ .
2. At normal operating temperatures optimum viscosity ranges from 80-180 SUS (16-39 cSt). Viscosity should never fall below 60 SUS (10 cSt) and, at the lowest expected start-up temperature, should not exceed 10,000 SUS (2158 cSt).
3. The fluid should be chemically stable, incorporating rust and oxidation inhibitors.

### Specific types of fluid that meet these requirements are:

- Premium quality, industrial anti-wear type hydraulic fluid
- Engine crankcase oil — SAE 10w, SAE 20w-20, SAE 30
- Automatic transmission oil
- Hydraulic transmission oil
- Synthetic fire resistant fluid — Quintolubric, Cosmolubric, or equivalent

**Note:** If the natural color of the fluid has become black or milky it is possible that an overheating or water contamination problem exists.

Take level readings when fluid is cold.

Information contained in this catalog is accurate as of the publication date and is subject to change without notice. Performance values are typical values. Customers are responsible for selecting products for their applications using normal engineering methods.

Eaton Corporation  
**Hydraulics Division**  
15151 Highway 5  
Eden Prairie, MN 55344  
Telephone: 612/937-7254  
Fax: 612/937-7130

Eaton Ltd.  
**Hydraulics Division**  
Glenrothes, Fife  
Scotland, KY7 4NW  
Telephone: +44 (0) 1592-771-771  
Fax: +44 (0) 1592-773-184

Eaton GmbH  
**Hydraulics Division**  
Am Schimmersfeld 7  
40880 Ratingen, Germany  
Telephone: +49 (0) 2102-406-830  
Fax: +49 (0) 2102-406-800

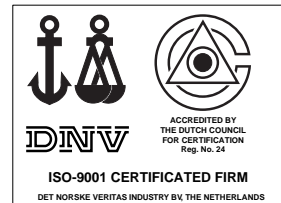

**Quality System Certified**  
Products in this catalog are  
manufactured in an  
ISO-9001-certified site.

[www.eatonhydraulics.com](http://www.eatonhydraulics.com)

Form No. 7-606  
March, 1995

Copyright Eaton Corporation 1995  
All Rights Reserved  
Printed in USA

