



Check Valves

C* G-800 Series

***Note**

The valve seat is installed through the front as shown on the C3G, C4G & C5G series. On the C2G series, the seat is installed from the back of the mounting surface.



CAUTION

When a C5G is used to replace a C2G or C3G, drill an appropriate hole in the mounting surface to accommodate the extra rest pin of the C5G and plug the unused hole. The pins prevent reversal of the valve on the mounting surface, which could cause a system malfunction and/or injury to personnel.

If body is required, order a new valve.

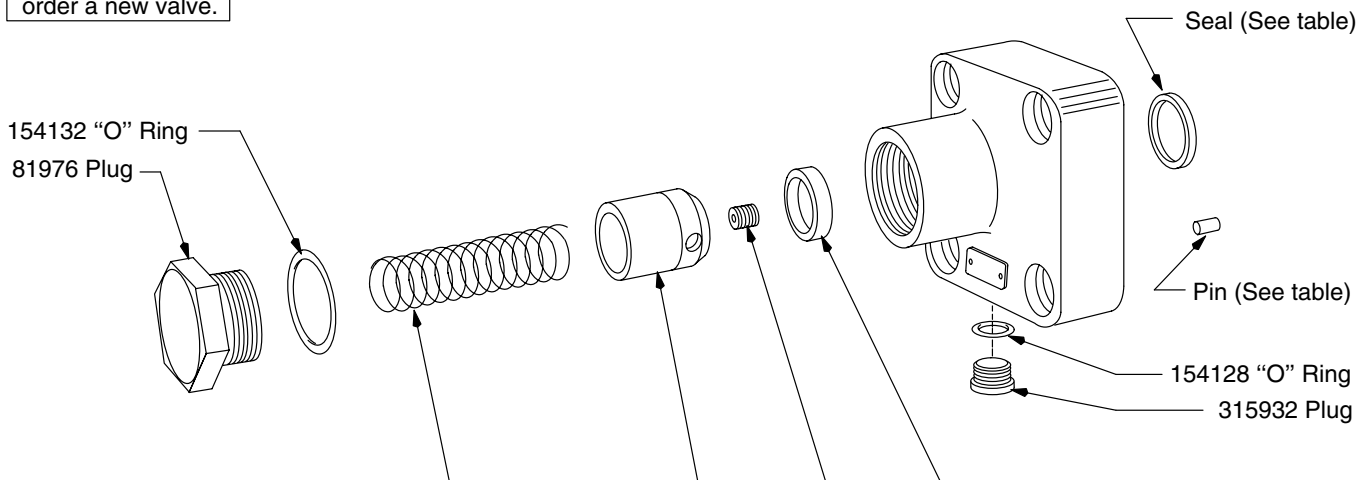

Model	Spring	Cracking Pressure	Valve	Plug	*Seat	Seals (2 req'd)	Pin (2 req'd)		
C2G-815	2943	5 PSI	81589	—	104403	262395	102679		
C3G/C4G-815					263886	154020	160571		
C5G-815					263886	154020	160571		
C2G-815-S2	36316	35 PSI			104403	262395	102679		
C3G/C4G-815-S2					263886	154020	160571		
C5G-815-S2					263886	154020	160571		
C2G-815-S3	25896	50 PSI			104403	262395	102679		
C3G/C4G-815-S3					263886	154020	160571		
C5G-815-S3					263886	154020	160571		
C2G-815-S8	32999	75 PSI			104403	262395	102679		
C3G/C4G-815-S8					263886	154020	160571		
C5G-815-S8					263886	154020	160571		
C2G-815-S12	2943	5 PSI	108708	81592	104403	262395	102679		
C3G/C4G-815-S12					263886	154020	160571		
C5G-815-S12					263886	154020	160571		
C2G-815-S17	84235	125 PSI			104403	262395	102679		
C3G/C4G-815-S17					263886	154020	160571		
C5G-815-S17					263886	154020	160571		
C2G-815-S19	2287	20 PSI			81589	—	104403	262395	102679
C3G/C4G-815-S19							263886	154020	160571
C5G-815-S19							263886	154020	160571
C2G-815-S20	83902	1 PSI					104403	262395	102679
C3G/C4G-815-S20							263886	154020	160571
C5G-815-S20							263886	154020	160571

Order and use mounting bolt kit BK CG825-615 if a C4G/C5G-825 valve is used to replace a C2G-825 or a C3G-825 valve.

If body is required, order a new valve.



CAUTION

When a C5G is used to replace a C2G or C3G, drill an appropriate hole in the mounting surface to accommodate the extra rest pin of the C5G and plug the unused hole. The pins prevent reversal of the valve on the mounting surface, which could cause a system malfunction and/or injury to personnel.

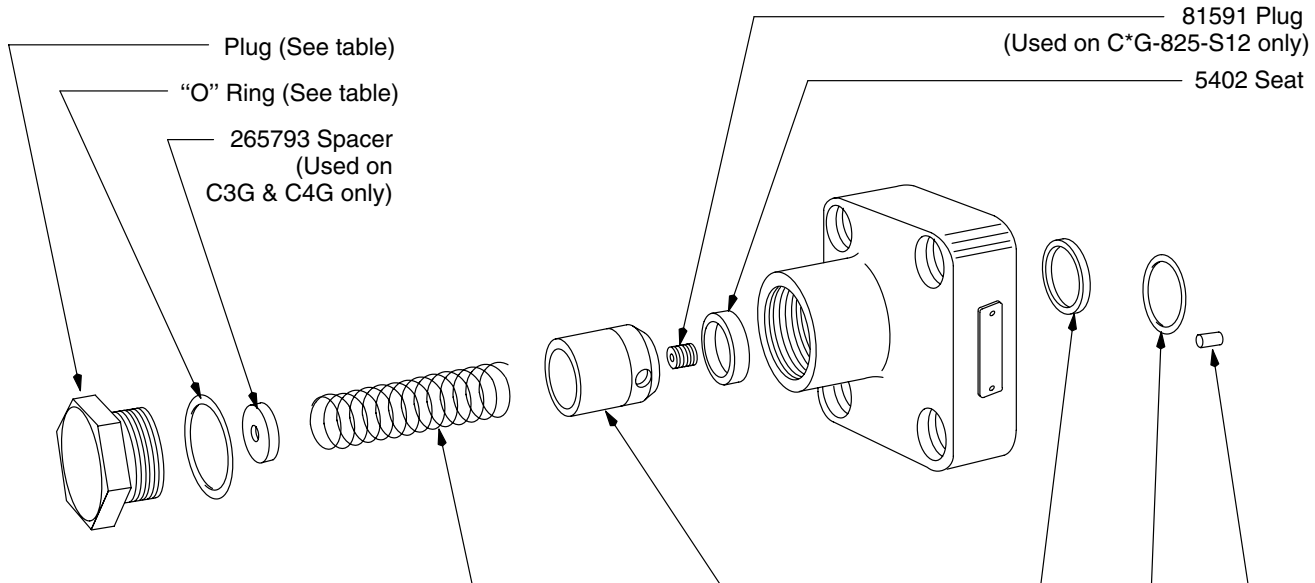

Model	Spring	Cracking Pressure	Valve
C2G-825	2284	5 PSI	108359
C3G/C4G-825			
C5G-825			
C2G-825-S2	2953	35 PSI	
C3G/C4G-825-S2			
C5G-825-S2			
C2G-825-S3	29059	50 PSI	
C3G/C4G-825-S3			
C5G-825-S3			
C2G-825-S8	39778	75 PSI	
C3G/C4G-825-S8			
C5G-825-S8			
C2G-825-S12	2284	5 PSI	182004
C3G/C4G-825-S12			
C5G-825-S12			
C2G-825-S17	64062	125 PSI	108359
C3G/C4G-825-S17			
C5G-825-S17			
C2G-825-S19	106669	20 PSI	
C3G/C4G-825-S19			
C5G-825-S19			
C2G-825-S20	2950	1 PSI	
C3G/C4G-825-S20			
C5G-825-S20			
C5G-825-S44	64062	125 PSI	

Model	Seals		Pin (2 req'd)
	Inlet	Outlet	
C2G	42310		102679
C3G			
C4G	▲154026	▲154077	160571
C5G			

Plug	"O" Ring	Model
14137	▲154077	C2G/C3G/C4G
347831	▲161467	C5G
Torque plug to 40-50 lb.ft. (54-68 N.m)		

C3G/C4G/C5G-825 Seal Kits	
Standard	919381
F3	919382

For satisfactory service life of these components, use full flow filtration to provide fluid which meets ISO cleanliness code 16/13 or cleaner. Selections from pressure, return, and in-line filter series are recommended.