

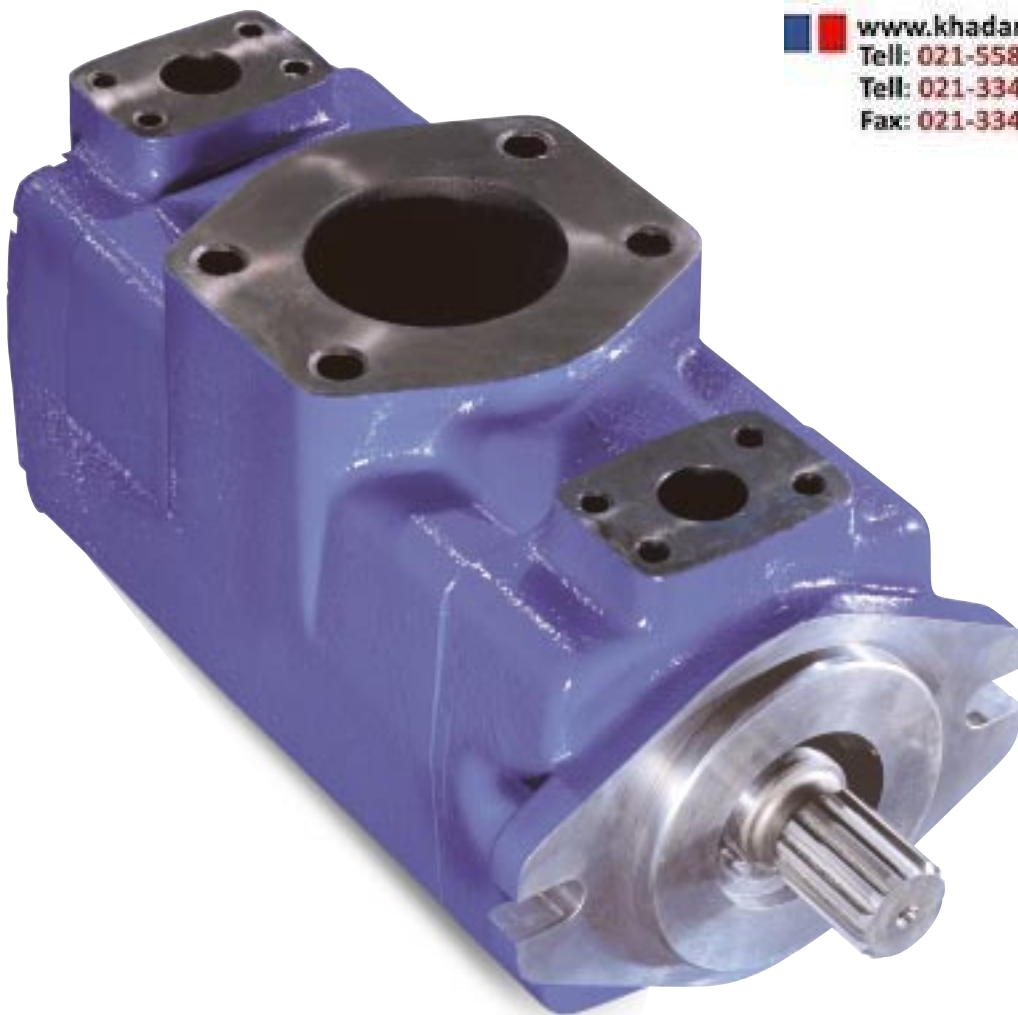

EATON

Vickers

VMQ Series Vane Pumps

Fixed Displacement
 For Industrial and
 Mobile Applications



www.khadamahydraulic.com
 Tell: 021-55882749
 Tell: 021-33488178
 Fax: 021-33488105

VICKERS®

Table of Contents

 www.khadamathydraulic.com
Tell: 021-55882749
Tell: 021-33488178
Fax: 021-33488105

Introduction and Application3
Section Views4
Description5
Operational Recommendations6
Performance Data - Industrial7
Performance Data - Mobile8
Sound Data9
Model Code - Single and Thru-Drive Pumps10
Model Code - Double Pumps11
Model Code - Triple Pumps12
Output Flow - Industrial13
Output Flow - Mobile21
Input Power - Industrial29
Input Power - Mobile37
Installation Dimensions - Single Pumps47
Installation Dimensions - Thru-Drive Pumps50
Pump Selection for Thru-Drive Pumps56
Installation Dimensions - Double Pumps57
Installation Dimensions - Triple Pumps61
Shaft Options63
Torque Loading67
Water Glycol Guidelines68
Fluid Cleanliness Recommendations69
Moments of Inertia and Weights70
Conversions71
Contact Details73

The latest state-of-the-art Vickers™ VMQ fixed displacement vane pumps set new standards of performance and efficiency for both industrial and mobile applications. Originally launched in 1995, the new VMQ series features design enhancements in all areas, resulting in a unique combination of higher pressure capabilities and outstandingly low noise levels.

Vickers™ VMQ pumps provide continuous pressure ratings up to 293 bar (4250 psi) for the 25 frame size and displacements up to 463 cm³/r (28.25 in³/r) with the triple pump version. In addition, further reductions in noise levels of an intrinsically quiet design offer real possibilities in traditional internal gear pump applications.

The highly seizure-resistant surface of the bronze wafer plate is particularly forgiving in cold start-up applications.

Performance

Vickers™ VMQ pumps meet global SAE and ISO standards. Three single-pump and three thru-drive frame sizes are available in 20 displacements, ranging from 10 cm³/r (0.62 in³/r) to 215 cm³/r (13.12 in³/r). Four double-pump configurations offer combined displacements from 20 cm³/r (1.23 in³/r) up to 373 cm³/r (22.76 in³/r). Two triple-pump configurations can combine displacements from 110 cm³/r (6.71 in³/r) to 463 cm³/r (28.25 in³/r).

Continuous outlet pressure ratings reach 293 bar (4250 psi), with permissible peak pressures up to 310 bar (4500 psi).

Features and Benefits

- Hydraulically balanced design (no internal radial forces) gives almost limitless shaft and bearing life.
- Extremely low noise levels enhance operator comfort.
- Shafts easily handle maximum pressures, ensuring exceptionally long shaft life.
- Unique bi-metallic wafer plate allows for cold start-ups.
- Efficient design means pumps perform under the harshest speed, temperature and cyclical loading conditions.
- Removable cartridges, usually with pump in-line, facilitate maintenance or flow changes.
- Twenty displacements allow selection of the best flow output for optimum use of energy.
- Interchangeable cartridges between single, thru-drive, double and triple pumps, simplify cartridge selection and reduce inventory.
- High volumetric efficiencies.
- Compatible with a wide variety of fluids.
- Shaft seal options: single seal design for “dry mount” applications, or double seal design for fluid separation in “wet mount” applications such as gearboxes or where lubricant is always present. (Wet mount applications extend shaft life.)

Applying Vane Pumps

Pump Characteristics

Minimum Speed

Minimum recommended starting speed, under fluid conditions stated above, is generally 600 r/min. However, the pump size, system characteristics and environmental conditions can raise or lower this speed. A lower speed can often be achieved after the pump has primed.

If low starting or operating speeds are required, consult your Eaton Hydraulics representative.

Rated Pressure

Pumps should not be operated at or near rated pressures at idle speeds for extended periods. Localized overheating and damage can result.

Never assume pumps in a double, triple or thru-drive pump assembly can be simultaneously loaded to rated pressure. Shaft loading must be checked for excessive torque.

Drive Alignment

Concentricity and angular alignment of shafts are important to pump life. Misalignment can induce heavy loads on bearings, causing premature failure. Flexible coupling halves must be aligned according to the coupling manufacturer's recommendations.

Universal Joints

When using double universal joint couplings, the shafts must be parallel and the yokes must be in line. The offset should be kept as low as possible. Maximum allowable offset will, of course, vary with application conditions. The pump shaft to universal joint diametral fit should be close (major diameter fit) with no looseness.

Mounting Pad Accessory Drives

A splined shaft is recommended on applications where the pump shaft is coupled directly

into a transmission or gearbox. Spline drives should be lubricated.

The possibility of interference between the shaft and transmission splines, due to tolerance stack-up, can exist.

To reduce this possibility, side tooth spline fits should be used. A side tooth fit and short length of engagement permits more flexibility and less tendency for side loading than does a major diameter fit spline or long spline engagement. As a general rule, the minimum spline engagement should not be less than 85% of the spline pitch diameter to ensure maximum shaft torque rating.

Mounting Dimensions Requirements

Dimensional control requirements of the customer's mounting pad to which the pump or motor is affixed are as follows.

Pilot Diameter

Concentricity of the customer's female pilot diameter relative to the effective axis of the female drive must be within 0,10 mm (0.004 in.) total indicator reading. The clearance between the male and female pilot diameters must be +0,01 to +0,05 mm (+0.0005 to +0.0020 in.).

Mounting Face

The customer's mounting face to which the pump or motor is affixed must be square to the axis of the female drive within 0,0381 mm per mm (0.0015 inch per inch).

Shafts

Dimensions of keyed shaft receivers must be between +0,003 and +0,03 mm (+0.0001 and +0.0010 in.) of the maximum shaft diameter shown on pages 63 and 64.

Typical Sections

 www.khadamathydraulic.com
Tell: 021-55882749
Tell: 021-33488178
Fax: 021-33488105

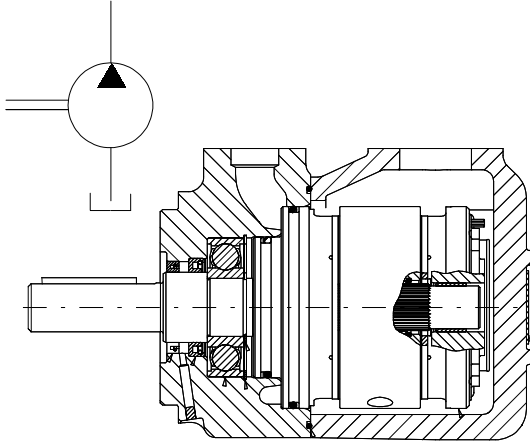

Single pump example

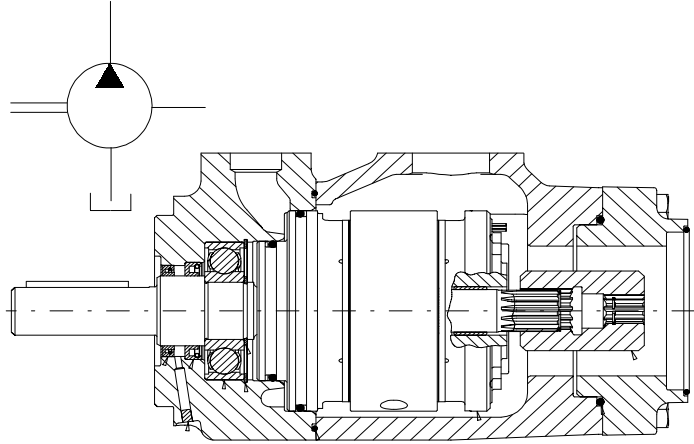

Thru-drive pump example

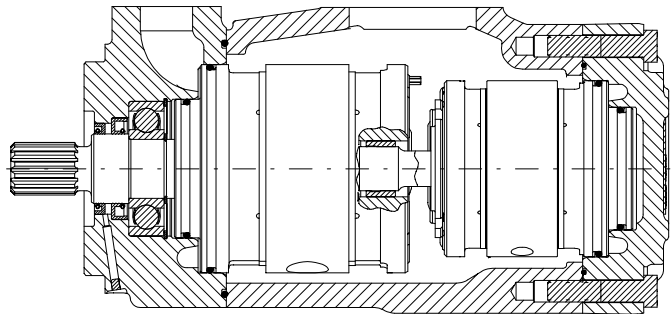
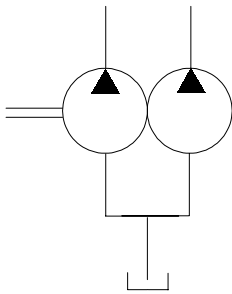

Double pump example

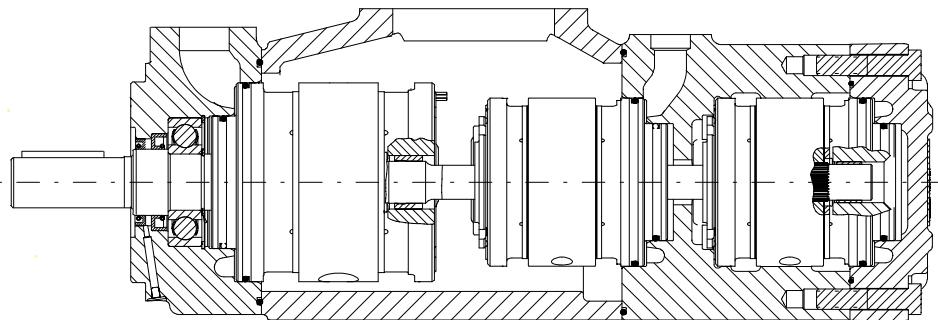
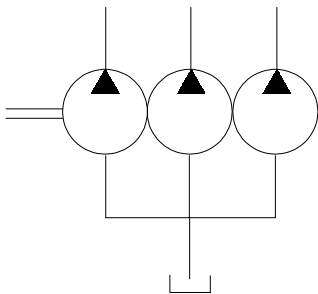

Triple pump example

Description

General

Pumps in this series are used to develop hydraulic fluid flow for the operation of Industrial and Mobile equipment. The positive displacement pumping cartridges are of the rotary vane type with shaft side loads hydraulically balanced. The flow rate depends on the pump size and the speed at which it is driven.

All units are designed so that the direction of rotation, pumping capacity and port positions can be readily changed to suit particular applications.

Assembly and Construction

The pump illustrated in Figure 1 is representative of all single pumps in this series. The unit consists principally of an inlet cover, outlet body, driveshaft and pumping cartridge.

The principal components of the cartridge are an elliptical cam ring, a slotted rotor splined to the driveshaft, an

inlet and outlet support plate, two wafer side plates, and 10/12 vanes and 10/12 pistons fitted to the rotor slots. Fluid enters the cartridge through the inlet port in the cover and is discharged through the outlet port in the body.

Principles of Operation

Pumping Cartridge

The action of the cartridge is illustrated in Figure 2. The rotor is driven within the ring by the driveshaft, which is coupled to a power source. As the rotor turns, centrifugal force on the vanes, aided by under-vane pressure fed from the outlet port, causes the vanes to follow the elliptical inner surface of the ring.

Radial movement of the vanes and turning of the rotor causes the chamber volume between the vanes to increase as the vanes pass the inlet sections of the ring. This results in a low pressure condition which allows atmospheric pressure to force fluid into the chambers.

An additional inlet fluid path exists through a drilled hole in the cam ring. This hole connects the inlet port directly to the inlet areas of the cam ring and provides an additional flow path for fluid to get into the cartridge.

Fluid is trapped between the vanes and carried past a sealing land to the outlet section of the ring. As the outlet section is approached, the chamber volume decreases and the fluid is forced out into the system. System pressure is fed under the vanes, assuring their sealing contact against the ring during normal operation.

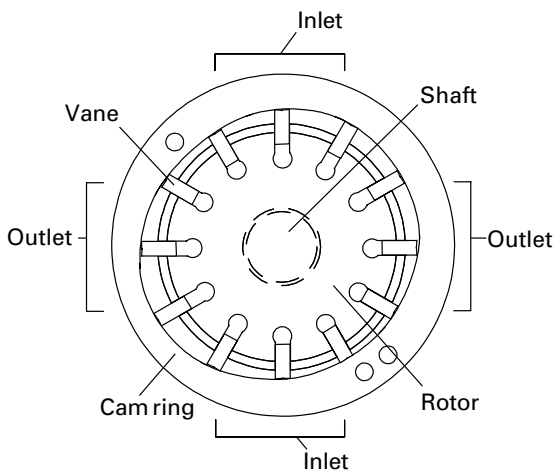

Figure 1

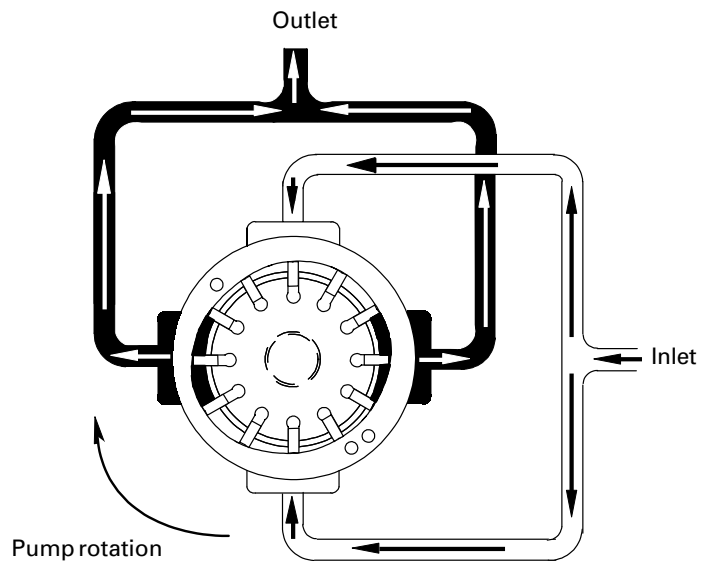

Figure 2

Operational Recommendations

Cold Starts

When operating with a fluid viscosity of over 54 cSt in industrial conditions, the outlet pressure should not exceed 50% of the maximum rating for the VMQ pump until the system has warmed up. When operating with a fluid viscosity of over 100cSt in mobile conditions, the speed and outlet pressure should not exceed 50% of the maximum ratings for the VMQ pump until the system has warmed up.

Example:

10 wt. oil at 90°F(32°C) will have a viscosity of 55 cSt. When the system fluid has a viscosity lower than 55 cSt, it is considered warmed up.

Extreme caution must be used when starting pumps with fluid viscosities greater than 860 cSt (4000 SUS). Care should be exercised to warm up the entire system, including remote cylinders and motors.

High Temperatures

Viscosities must not be less than the minimum values shown in the table below. Temperatures should not exceed 99°C (210°F) because the life expectancy of cartridge kits and elastomers will decrease.

Drive Data

Pumps are assembled for right hand (clockwise) rotation or left hand (counterclockwise) rotation. Rotation is viewed from the shaft end. Inlet and outlet ports remain the same regardless of the direction of shaft rotation.

Pump Drive

Direct coaxial drive is recommended. If drives imposing radial shaft loads are considered, please consult your Vickers representative.

Start-up Procedure

Make sure the reservoir and circuit are clean and free of dirt/debris prior to filling with hydraulic fluid.

Fill the reservoir with filtered oil and fill to a level sufficient enough to prevent vortexing at suction connection to pump inlet. It is good practice to clean up the system by flushing and filtering using an external slave pump.

Before starting the pump, fill with fluid through one of the ports. This is particularly important if the pump is above the fluid level of the reservoir.

When initially starting the pump, remove all trapped air from the system. This can be accomplished by loosening the pump outlet fittings or connections before starting the pump or by using an air bleed valve. All inlet connections must be tight to prevent air leaks. An air bleed valve is available for this purpose. (Refer to catalog 690.)

CAUTION:



No Case Drain.

These pumps are drained internally into their inlet. System pressure at the pump inlet connection may not exceed 1,4 bar (20 psi).

CAUTION:



Low Outlet Pressure.

Do not run a pump with the outlet pressure lower than the inlet pressure. This causes operating noise and vane instability.

Once the pump is started, it should prime within a few seconds. If the pump does not prime, check to make sure that there are no restrictions between the reservoir and the inlet to the pump, and that there are no air leaks in the inlet line and connections. Also check to make sure that trapped air can escape at the pump outlet.

After the pump is primed, tighten the loose outlet connections, then operate for five to ten minutes unloaded to remove all trapped air from the circuit.

If the reservoir has a sight gage, make sure the fluid is clear - not milky.

Operating Guidelines

INLET PRESSURE AND OPERATING TEMPERATURE REQUIREMENTS

	Minimum Inlet Pressure Absolute bar (PSI)	Recommended Operating Inlet Pressure - Gage bar (PSI)	Maximum Positive Inlet Pressure - Gage bar (PSI)	Maximum Continuous Operating Temp. C° (F°)	Maximum Intermittent Operating Temp. C° (F°)
Industrial	0.83 (12.0)	0 to 0.35 (0 to 5.0)	1.4 (20)	66 (150)	74 (165)
Mobile	1.0 (14.5)	0 to 0.35 (0 to 5.0)	1.4 (20)	82 (180)	99 (210)

Hydraulic Fluid Recommendations

VISCOSITY REQUIREMENTS

	Minimum Intermittent Viscosity cSt	Minimum Continuous Viscosity cSt	Optimum Operating Viscosity Range cSt	Maximum Viscosity at Pressure cSt	Viscosity Range Requiring <50% Outlet Pressure cSt	Maximum Viscosity at Startup cSt
Industrial	10	13	16-40	54	54-860	860
Mobile	6.5	9	16-40	100	100-2000	2000

Typical Performance Data - Industrial

49°C (120°F), SAE 10W oil,
26 cSt (128 SUS)

FRAME SIZE	DISPLACEMENT		PRESSURE RATING (MAXIMUM)				MAXIMUM SPEED RATING AT 0 BAR (0 PSIG) INLET	OUTLET FLOW AT 1800 R/MIN 210 BAR (3000 PSI)		INPUT POWER AT 1800 R/MIN 210 BAR (3000 PSI)	
	CM ³ /R	(IN ³ /R)	CONTINUOUS		PEAK ■			L/MIN	(USGPM)	KW	(HP)
			BAR	(PSI)	BAR	(PSI)					
25	10	(0.62)	293	(4250)	310	(4500)	1800	14,3	(3.8)	6,6	(8.9)
	16	(0.98)	293	(4250)	310	(4500)	1800	24,9	(6.6)	10,4	(14.0)
	20	(1.23)	293	(4250)	310	(4500)	1800	32,7	(8.6)	13,1	(17.6)
	25	(1.58)	293	(4250)	310	(4500)	1800	42,7	(11.3)	16,8	(22.6)
	32	(1.96)	293	(4250)	310	(4500)	1800	53,3	(14.1)	20,9	(28.1)
	40	(2.44)	293	(4250)	310	(4500)	1800	61,6	(15.9)	25,8	(34.4)
	45	(2.75)	293	(4250)	310	(4500)	1800	71,0	(18.3)	29,1	(38.8)
	50	(3.05)	293	(4250)	310	(4500)	1800	80,0	(20.6)	32,2	(43.0)
	63	(3.84)	293	(4250)	310	(4500)	1800	103,9	(26.8)	40,6	(54.1)
	71	(4.33)	293	(4250)	310	(4500)	1800	118,7	(30.6)	45,8	(61.0)
	80	(4.88)	293	(4250)	310	(4500)	1800	136,1	(35.1)	51,6	(68.8)
35	90	(5.49)	262	(3800)	276	(4000)	1800	153,9	(40.65)	71,9	(96.5)
	90	(5.49)	262	(3800)	276	(4000)	1800	149,7	(38.6)	58,7	(78.3)
	100	(6.10)	262	(3800)	276	(4000)	1800	168,1	(43.4)	65,2	(87.0)
	112	(6.83)	262	(3800)	276	(4000)	1800	190,1	(49.1)	73,0	(97.4)
	125	(7.63)	262	(3800)	276	(4000)	1800	214,3	(55.3)	81,6	(108.8)
	135	(8.24)	262	(3800)	276	(4000)	1800	233,9	(60.4)	88,1	(117.5)
	140	(8.47)	220	(3200)	241	(3500)	1800	240,0	(63.42)	92,8	(124.4)
	158	(9.64)	220	(3200)	241	(3500)	1800	272,6	(72.02)	109,7	(147.1)
45	140	(8.54)	262	(3800)	276	(4000)	1800	232,0	(60.0)	92,5	(123.3)
	160	(9.76)	262	(3800)	276	(4000)	1800	269,3	(69.5)	105,7	(141.0)
	180	(10.98)	262	(3800)	276	(4000)	1800	306,2	(79.0)	118,9	(158.6)
	195	(11.89)	262	(3800)	276	(4000)	1800	332,0	(86.0)	128,8	(171.7)
	215	(13.12)	220	(3200)	241	(3500)	1800	362,6	(95.8)	139,7	(187.4)

■ Peak pressure 0.5 seconds < 0.5 seconds

Typical Performance Data - Mobile

82°C (180°F), SAE 10W oil,
9 cSt (55 SUS)

FRAME SIZE	DISPLACEMENT		PRESSURE RATING (MAXIMUM)				MAXIMUM SPEED RATING AT 0 BAR (0 PSIG) INLET	OUTLET FLOW AT MAXIMUM R/MIN, 210 BAR (3000 PSI)		INPUT POWER AT MAXIMUM R/MIN, 210 BAR (3000 PSI)	
			CONTINUOUS		PEAK ■			L/MIN	(USGPM)	KW	(HP)
	CM ³ /R	(IN ³ /R)	BAR	(PSI)	BAR	(PSI)					
25	10	(0.62)	280	(4060)	310	(4500)	3000	21,1	(5.6)	11,1	(14.8)
	16	(0.98)	280	(4060)	310	(4500)	3000	38,8	(10.3)	17,6	(23.4)
	20	(1.23)	280	(4060)	310	(4500)	3000	51,1	(13.5)	22,0	(29.4)
	25	(1.58)	280	(4060)	310	(4500)	3000	68,3	(18.0)	28,3	(37.7)
	32	(1.96)	280	(4060)	310	(4500)	3000	88,4	(23.4)	35,1	(46.8)
	40	(2.44)	280	(4060)	310	(4500)	2600	77,4	(20.4)	38,1	(50.1)
	45	(2.75)	280	(4060)	310	(4500)	2600	90,6	(23.9)	42,9	(57.2)
	50	(3.05)	280	(4060)	310	(4500)	2600	103,3	(27.3)	47,6	(63.5)
	63	(3.84)	280	(4060)	310	(4500)	2600	137,0	(36.2)	59,9	(79.9)
	71	(4.33)	280	(4060)	310	(4500)	2600	157,9	(41.7)	67,6	(90.1)
	80	(4.88)	280	(4060)	310	(4500)	2600	182,3	(48.2)	77,3	(102.9)
35	90	(5.49)	248	(3600)	276	(4000)	2200	172,5	(48.57)	85,8	(115.0)
	90	(5.49)	250	(3625)	276	(4000)	2400	180,2	(47.6)	79,1	(105.4)
	100	(6.10)	250	(3625)	276	(4000)	2400	204,2	(53.9)	87,9	(117.2)
	112	(6.83)	250	(3625)	276	(4000)	2400	232,9	(61.5)	98,4	(131.2)
	125	(7.63)	250	(3625)	276	(4000)	2400	264,4	(69.8)	109,9	(146.5)
	135	(8.24)	250	(3625)	276	(4000)	2200	259,0	(68.4)	113,5	(144.8)
	140	(8.47)	210	(3000)	220	(3200)	2200	275,1	(72.66)	112,9	(151.5)
45	158	(9.64)	210	(3000)	220	(3200)	2200	326,2	(86.18)	134,4	(180.2)
	140	(8.54)	250	(3625)	276	(4000)	2200	268,2	(70.9)	113,5	(151.4)
	160	(9.76)	250	(3625)	276	(4000)	2200	312,1	(82.5)	129,8	(173.0)
	180	(10.98)	250	(3625)	276	(4000)	2200	356,1	(94.1)	146,0	(194.6)
	195	(11.89)	250	(3625)	276	(4000)	2200	379,7	(100.3)	158,1	(210.8)
215	(13.12)	220	(3200)	241	(3500)	2200	425,5	(112.4)	171,5	(230)	

■ Peak pressure 0.5 seconds < 0.5 seconds

Typical Sound Data

49°C (120°F), SAE 10W oil,
0 bar (0psig) inlet

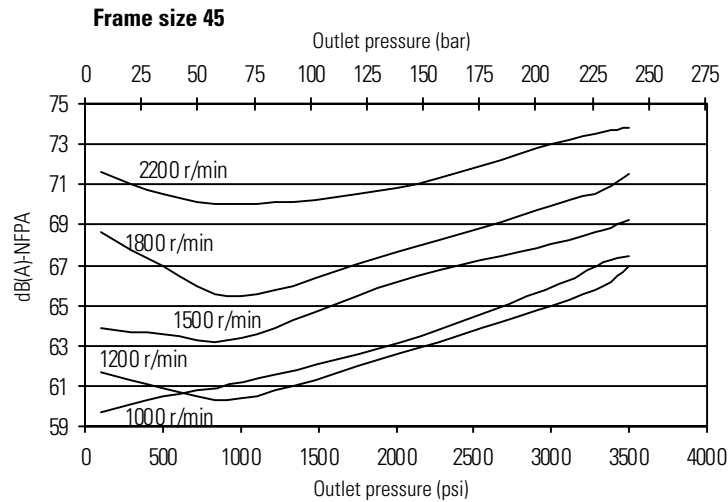
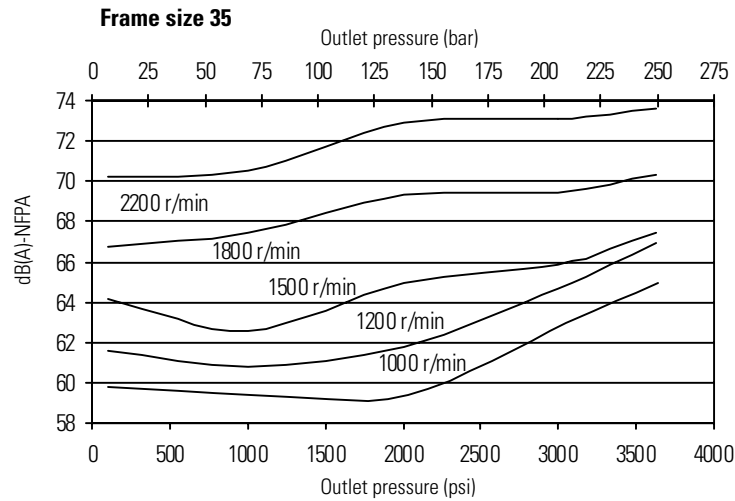
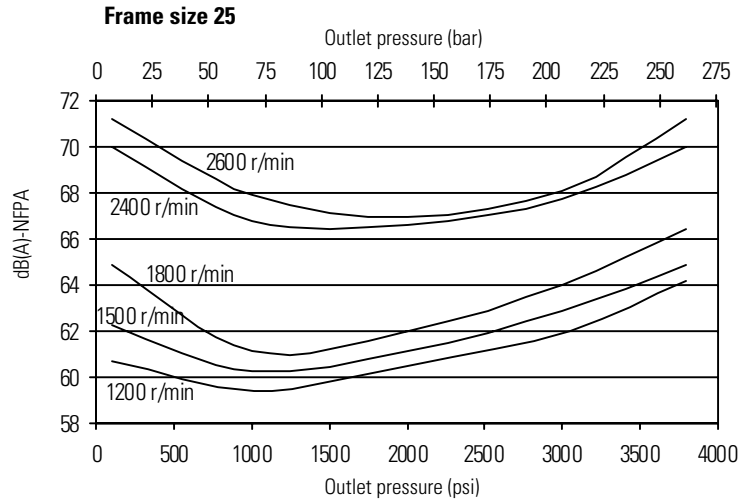

Model Code - Double Pumps

VMQ2	**	**	S	***	***	*	0	**	00	*	*	*	*	*	*	*	*	00	*	0	32													
1	2	3	4	5	6	7	8	9	10	11	12	13	14	15	16	17	18	19	20	21	22	23	24	25	26	27	28	29	30	31	32	33	34	35

1 2 3 4 Series designation
VMQ2 – Vane pump double series

5 6 Frame size (front section)
25 – 10-90 cm³/r
(0.62-5.49 in³/r)
35 – 90-158 cm³/r
(5.49-9.64 in³/r)
45 – 140-215 cm³/r
(8.54-13.12 in³/r)

7 8 Frame size (rear section)
25 – 10-90 cm³/r
(0.62-5.49 in³/r)
35 – 90-158 cm³/r
(5.49-9.64 in³/r)

9 Pump type
S – Standard

10 11 12 Displacement (front section)
Frame size 25
010 – 10 cm³/r (0.62 in³/r)
016 – 16 cm³/r (0.98 in³/r)
020 – 20 cm³/r (1.23 in³/r)
025 – 25 cm³/r (1.58 in³/r)
032 – 32 cm³/r (1.96 in³/r)
040 – 40 cm³/r (2.44 in³/r)
045 – 45 cm³/r (2.75 in³/r)
050 – 50 cm³/r (3.05 in³/r)
063 – 63 cm³/r (3.84 in³/r)
071 – 71 cm³/r (4.33 in³/r)
080 – 80 cm³/r (4.88 in³/r)
090 – 90 cm³/r (5.49 in³/r)
Frame size 35
090 – 90 cm³/r (5.49 in³/r)
100 – 100 cm³/r (6.10 in³/r)
112 – 112 cm³/r (6.83 in³/r)
125 – 125 cm³/r (7.63 in³/r)
135 – 135 cm³/r (8.24 in³/r)
140 – 140 cm³/r (8.54 in³/r)
158 – 158 cm³/r (9.64 in³/r)
Frame size 45
140 – 140 cm³/r (8.54 in³/r)
160 – 160 cm³/r (9.76 in³/r)
180 – 180 cm³/r (10.98 in³/r)
195 – 195 cm³/r (11.89 in³/r)
215 – 215 cm³/r (13.12 in³/r)

13 14 15 Displacement (rear section)
Frame size 25
010 – 10 cm³/r (0.62 in³/r)
016 – 16 cm³/r (0.98 in³/r)
020 – 20 cm³/r (1.23 in³/r)
025 – 25 cm³/r (1.58 in³/r)

032 – 32 cm³/r (1.96 in³/r)
040 – 40 cm³/r (2.44 in³/r)
045 – 45 cm³/r (2.75 in³/r)
050 – 50 cm³/r (3.05 in³/r)
063 – 63 cm³/r (3.84 in³/r)
071 – 71 cm³/r (4.33 in³/r)
080 – 80 cm³/r (4.88 in³/r)
090 – 90 cm³/r (5.49 in³/r)
Frame size 35
090 – 90 cm³/r (5.49 in³/r)
100 – 100 cm³/r (6.10 in³/r)
112 – 112 cm³/r (6.83 in³/r)
125 – 125 cm³/r (7.63 in³/r)
135 – 135 cm³/r (8.24 in³/r)
140 – 140 cm³/r (8.54 in³/r)
158 – 158 cm³/r (9.64 in³/r)

16 Front flange mounting style
A – (Frame size 25 only)
SAE B 2-bolt
101,60 (4.000) x 9,4
(0.37) pilot
14,4 (0.57) slots on
146,0 (5.75) bolt circle
B – (Frame sizes 35 & 45 only)
SAE C 2-bolt
127,00 (5.000) x 12,4
(0.49) pilot
17,6 (0.69) slots on
181,0 (7.13) bolt circle
C – (Frame size 25 only)
ISO 3019/2 100A2HW
2-bolt
100,00 (3.937) x 9,2
(0.36) pilot
14,1 (0.56) slots on
140,0 (5.51) bolt circle
D – (Frame sizes 35 & 45 only)
ISO 3019/2 125A2HW
2-bolt
125,00 (4.921) x 9,2
(0.36) pilot
18,1 (0.71) slots on
180,0 (7.09) bolt circle

17 Adapter flange
0 – None (standard double pump)

18 19 Input shaft type*
01 – SAE J744 keyed
Frame size 25:
25,40 (1.000)
Frame size 35:
31,75 (1.250)
Frame size 45:
38,10 (1.500)

02 – SAE J744 splined
Frame size 25: B-B
Frame size 35: C
Frame size 45: C-C
03 – ISO 3019/2 keyed
Frame size 25:
25,00 (0.984)
Frame size 35:
32,00 (1.260)
Frame size 45:
40,00 (1.575)
05 – SAE J744 keyed
Frame size 25:
31,75 (1.250)
Frame size 35:
38,10 (1.500)
Frame size 45:
44,45 (1.750)
06 – SAE J744 splined
Frame size 25: C
Frame size 35: C-C
Frame size 45: D
07 – ISO 3019/2 keyed
Frame size 25:
32,00 (1.260)
Frame size 35:
40,00 (1.575)
09 – SAE J744 Spline
Frame size 45: C

20 21 Output shaft coupling
00 – None (standard double pump)

22 Inlet port type
A – SAE J518 4-split flange
B – ISO 6162 4-bolt flange

23 Front outlet port type
A – SAE J518 4-bolt flange
B – ISO 6162 4-bolt flange

24 Rear outlet port type
A – SAE J518 4-bolt flange
B – ISO 6162 4-bolt flange

25 Front outlet port position
Viewed from cover end of pump
A – Opposite inlet port
B – 90° CCW to inlet port
C – In-Line with front inlet port
D – 90° CW to inlet port

26 Rear outlet port position
Viewed from cover end of pump
A – 135° CCW to inlet port
(not available with 2525)
B – 45° CCW to inlet port
(not available with 2525)
C – 45° CW to inlet port
(not available with 2525)
D – 135° CW to inlet port
(not available with 2525)
E – Opposite inlet port
(2525 only)
F – 90° CCW to inlet port
(2525 only)
G – In-line with inlet port
(2525 only)
H – 90° CW to inlet port
(2525 only)

27 Shaft Seal
A – Single, primary
B – Double, secondary
(spring side out)
Recommended for wet mount applications

28 Seal Type
N – Buna-N
V – Viton
W – Buna-N with Viton shaft seal(s)

29 Shaft rotation
Viewed from shaft end of pump
L – Left Hand (CCW)
R – Right Hand (CW)

30 31 Special features
00 – None

32 Paint
0 – None
A – Blue

33 Customer identification
0 – None

34 35 Design code
32 – 32 design
Installation dimensions remain unchanged for design numbers 30 to 39 inclusive.

* Verify shaft torque ratings meet or exceed input torque requirements (see pg. 67).

Model Code - Triple Pumps

VMQ3 ** ** 25 * *** *** * ** * * * * * * 00 * 0 32**

1 2 3 4 5 6 7 8 9 10 11 12 13 14 15 16 17 18 19 20 21 22 23 24 25 26 27 28 29 30 31 32 33 34 35

1 2 3 4 Series designation

VMQ3 – Vane pump triple series

5 6 Frame size (front section)

35 – 90-158 cm ³/_r
(5.49-9.64 in ³/_r)
45 – 140-215 cm ³/_r
(8.54-13.12 in ³/_r)

7 8 Frame size (middle section)

25 – 10-90 cm ³/_r
(0.62-5.49 in ³/_r)
35 – 90-158 cm ³/_r
(5.49-9.64 in ³/_r)

9 10 Frame size (rear section)

25 – 10-90 cm ³/_r
(0.62-5.49 in ³/_r)

11 12 13 Displacement (front section)

Frame size 35
090 – 90 cm ³/_r (5.49 in ³/_r)
100 – 100 cm ³/_r (6.10 in ³/_r)
112 – 112 cm ³/_r (6.83 in ³/_r)
125 – 125 cm ³/_r (7.63 in ³/_r)
135 – 135 cm ³/_r (8.24 in ³/_r)
140 – 140 cm ³/_r (8.54 in ³/_r)
158 – 158 cm ³/_r (9.64 in ³/_r)

Frame size 45
140 – 140 cm ³/_r (8.54 in ³/_r)
160 – 160 cm ³/_r (9.76 in ³/_r)
180 – 180 cm ³/_r (10.98 in ³/_r)
195 – 195 cm ³/_r (11.89 in ³/_r)
215 – 215 cm ³/_r (13.12 in ³/_r)

14 15 16 Displacement (middle section)

Frame size 25
010 – 10 cm ³/_r (0.62 in ³/_r)
016 – 16 cm ³/_r (0.98 in ³/_r)
020 – 20 cm ³/_r (1.23 in ³/_r)
025 – 25 cm ³/_r (1.58 in ³/_r)
032 – 32 cm ³/_r (1.96 in ³/_r)
040 – 40 cm ³/_r (2.44 in ³/_r)
045 – 45 cm ³/_r (2.75 in ³/_r)
050 – 50 cm ³/_r (3.05 in ³/_r)
063 – 63 cm ³/_r (3.84 in ³/_r)
071 – 71 cm ³/_r (4.33 in ³/_r)
080 – 80 cm ³/_r (4.88 in ³/_r)
090 – 90 cm ³/_r (5.49 in ³/_r)

Frame size 35

090 – 90 cm ³/_r (5.49 in ³/_r)
100 – 100 cm ³/_r (6.10 in ³/_r)
112 – 112 cm ³/_r (6.83 in ³/_r)
125 – 125 cm ³/_r (7.63 in ³/_r)
135 – 135 cm ³/_r (8.24 in ³/_r)
140 – 140 cm ³/_r (8.47 in ³/_r)
158 – 158 cm ³/_r (9.64 in ³/_r)

17 18 19 Displacement (rear section)

Frame size 25
010 – 10 cm ³/_r (0.62 in ³/_r)
016 – 16 cm ³/_r (0.98 in ³/_r)
020 – 20 cm ³/_r (1.23 in ³/_r)
025 – 25 cm ³/_r (1.58 in ³/_r)
032 – 32 cm ³/_r (1.96 in ³/_r)
040 – 40 cm ³/_r (2.44 in ³/_r)
045 – 45 cm ³/_r (2.75 in ³/_r)
050 – 50 cm ³/_r (3.05 in ³/_r)
063 – 63 cm ³/_r (3.84 in ³/_r)
071 – 71 cm ³/_r (4.33 in ³/_r)
080 – 80 cm ³/_r (4.88 in ³/_r)
090 – 90 cm ³/_r (5.49 in ³/_r)

20 Front flange mounting style

A – SAE C 2-bolt
SAE J744 127-2
127,00 (5.000) x 12,4
(0.49) pilot
17,6 (0.69) slots on
181,0 (7.13) bolt circle
B – ISO 3019/2 125A2HW
2-bolt
125,00 (4.921) x 9,2
(0.36) pilot
18,1 (0.71) slots on
180,0 (7.09) bolt circle

21 22 Input shaft type*

01 – SAE J744 keyed
Frame size 35:
31,75 (1.250)
Frame size 45:
38,10 (1.500)
02 – SAE J744 splined
Frame size 35: C
Frame size 45: C-C
03 – ISO 3019/2 keyed
Frame size 35:
32,00 (1.260)
Frame size 45:
40,00 (1.575)

05 – SAE J744 keyed

Frame size 35:
38,10 (1.500)

Frame size 45:
44,45 (1.750)

06 – SAE J744 splined

Frame size 35: C-C
Frame size 45: D

07 – ISO 3019/2 keyed

Frame size 35:
40,00 (1.575)

23 Port type

A – Inlet: SAE J518 4-bolt
flange
Front outlet: SAE J518
4-bolt flange
Middle outlet: SAE J518
4-bolt flange
Rear outlet: SAE J518
4-bolt flange
B – Inlet: ISO 6162 4-bolt
flange
Front outlet: ISO 6162
4-bolt flange
Middle outlet: ISO 6162
4-bolt flange
Rear outlet: ISO 6162
4-bolt flange

24 Front outlet port position
Viewed from cover end
of pump

A – Opposite inlet port
B – 90° CCW to inlet port
C – In-line with inlet port
D – 90° CW to inlet port

25 Middle outlet port position
Viewed from cover end
of pump

A – Opposite inlet port
B – 90° CCW to inlet port
C – In-line with inlet port
D – 90° CW to inlet port

26 Rear outlet port position
Viewed from cover end
of pump

352525 units
A – 135° CCW to inlet port
B – 45° CCW to inlet port
C – 45° CW to inlet port
D – 135° CW to inlet port
453525 units
E – Opposite inlet port
F – 90° CCW to inlet port
G – In-line with inlet port
H – 90° CW to inlet port

27 Shaft seal

A – Single, primary
B – Double, secondary
(spring side out)
Recommended for wet
mount applications

28 Seal type

N – Buna N
V – Viton
W – Buna N with Viton
shaft seal(s)

29 Shaft rotation
Viewed from shaft end
of pump

L – Left hand (CCW)
R – Right hand (CW)

30 31 Special features

00 – None

32 Paint

0 – None
A – Blue

33 Customer identification

0 – None

34 35 Design code

32 – 32 design
Installation dimensions
remain unchanged for
design numbers 31 to
39 inclusive.

* Verify shaft torque ratings meet or exceed input torque requirements (see pg. 67).

Typical Output Flow - Industrial

49°C (120°F), SAE 10W oil,
26 cSt (128 SUS)

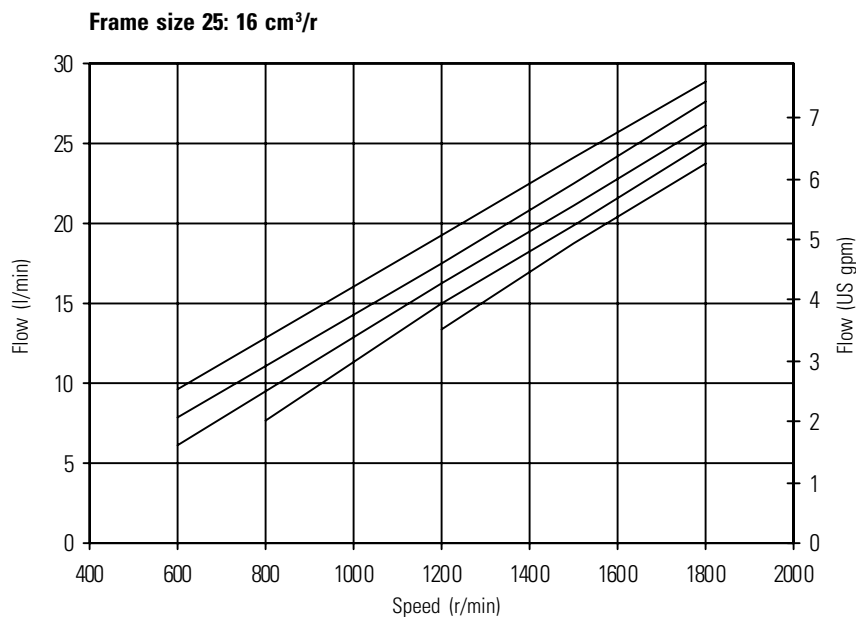
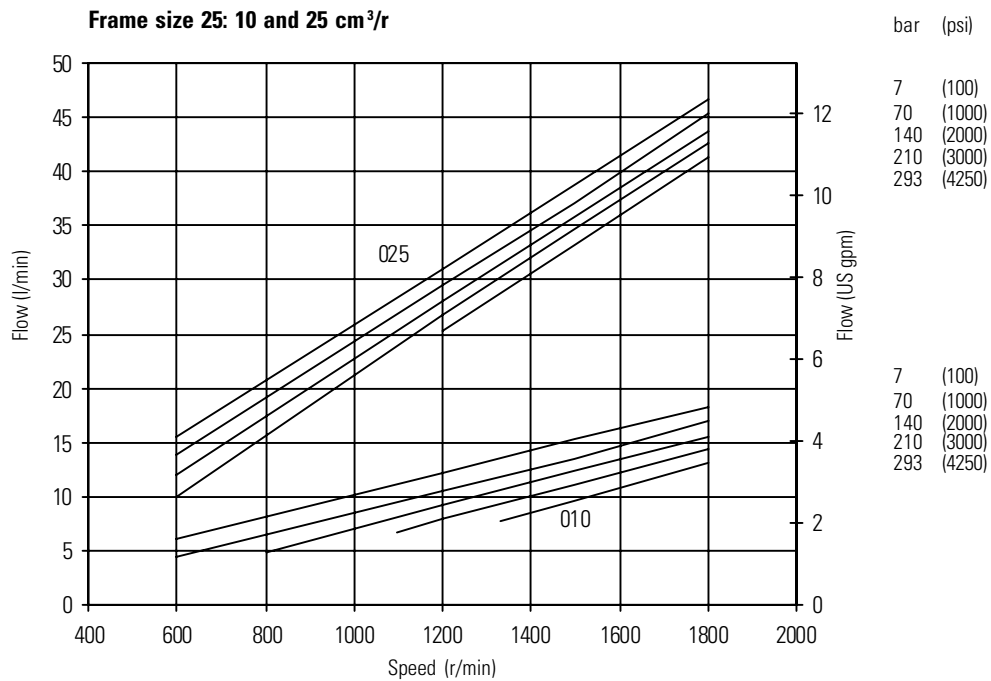

Typical Output Flow - Industrial (cont.)

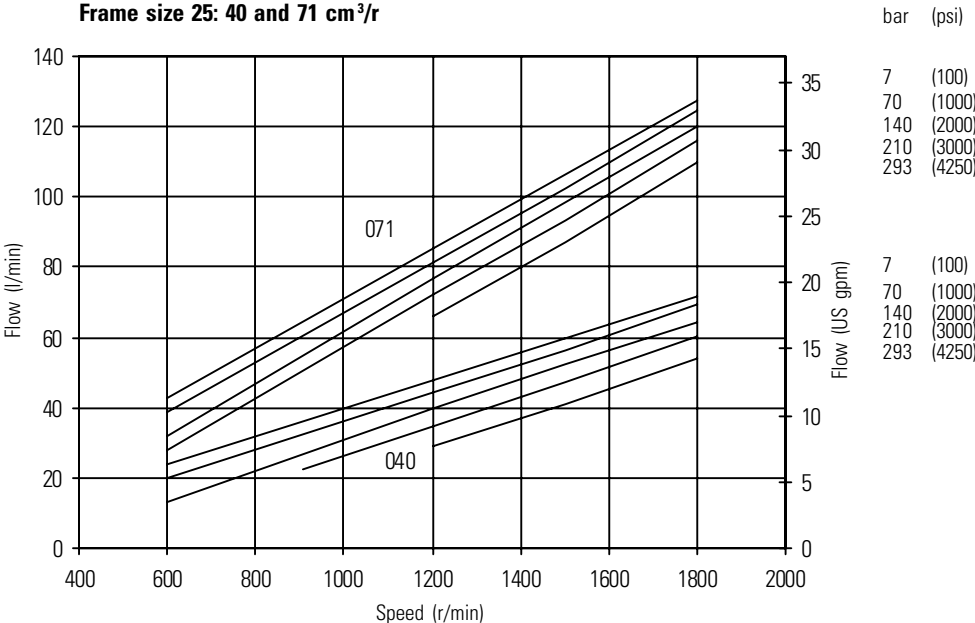
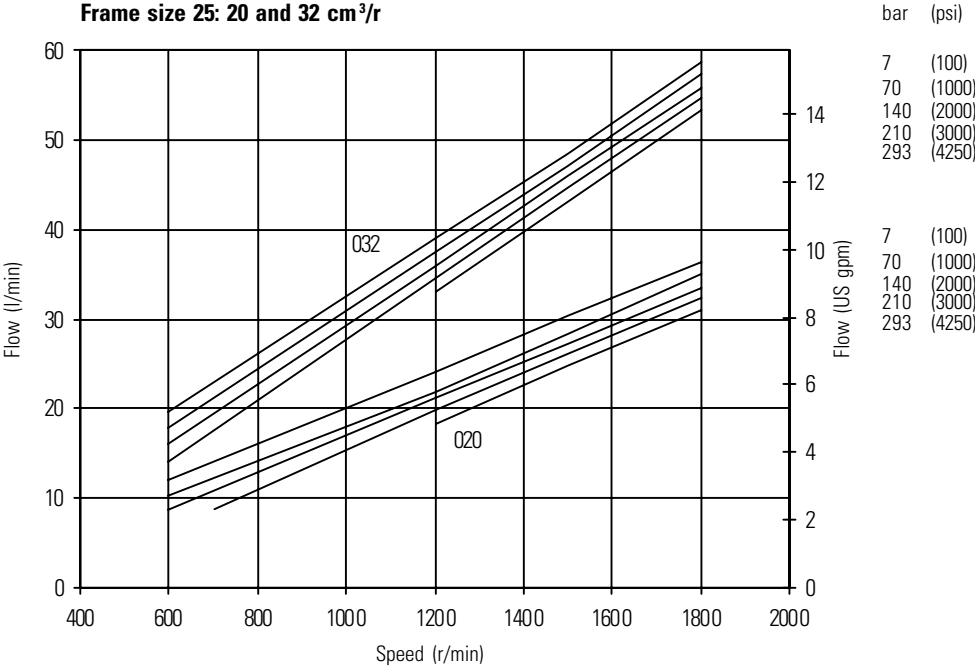

Typical Output Flow - Industrial (cont.)

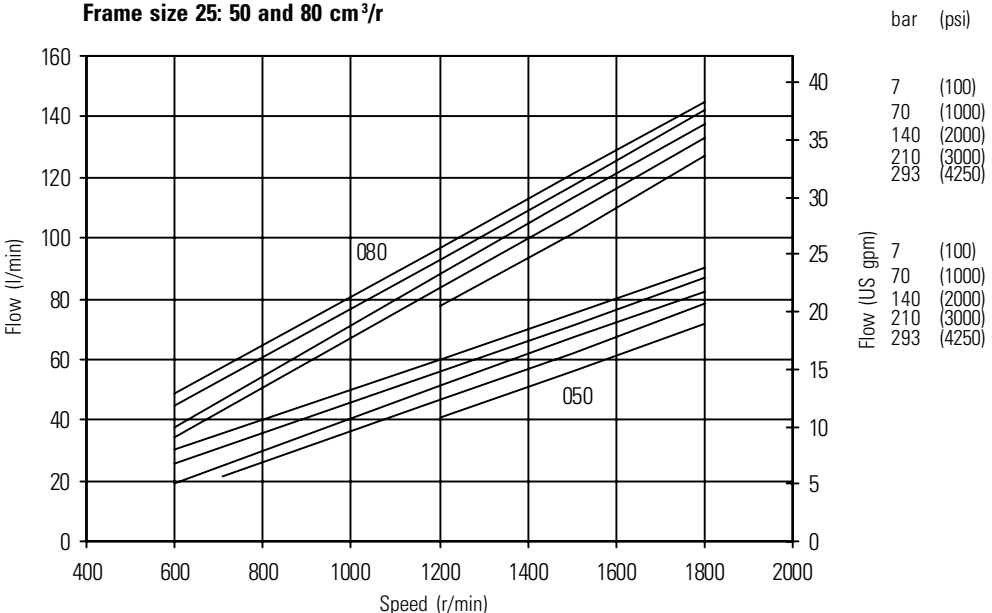
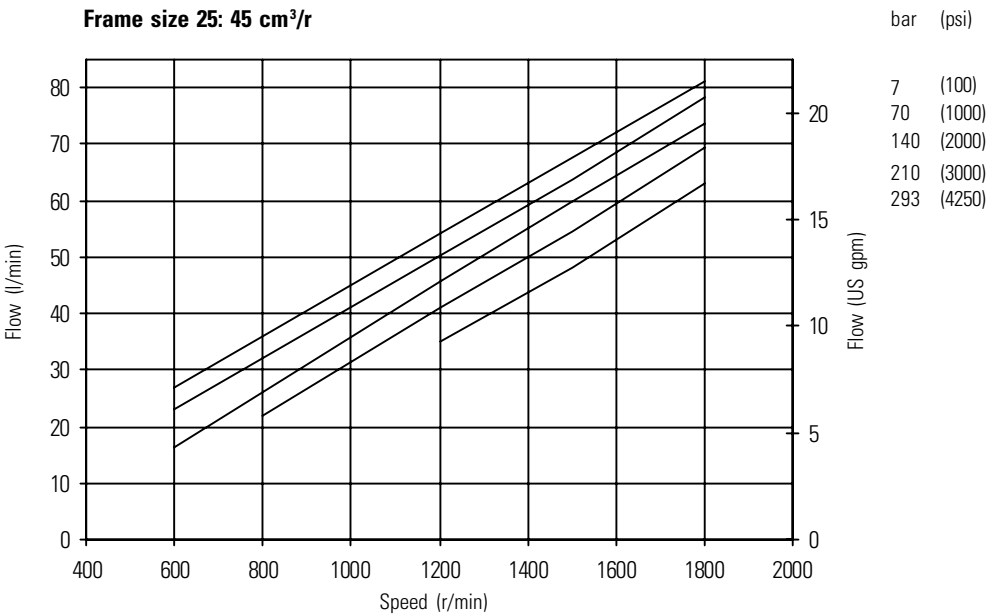

Typical Output Flow - Industrial (cont.)

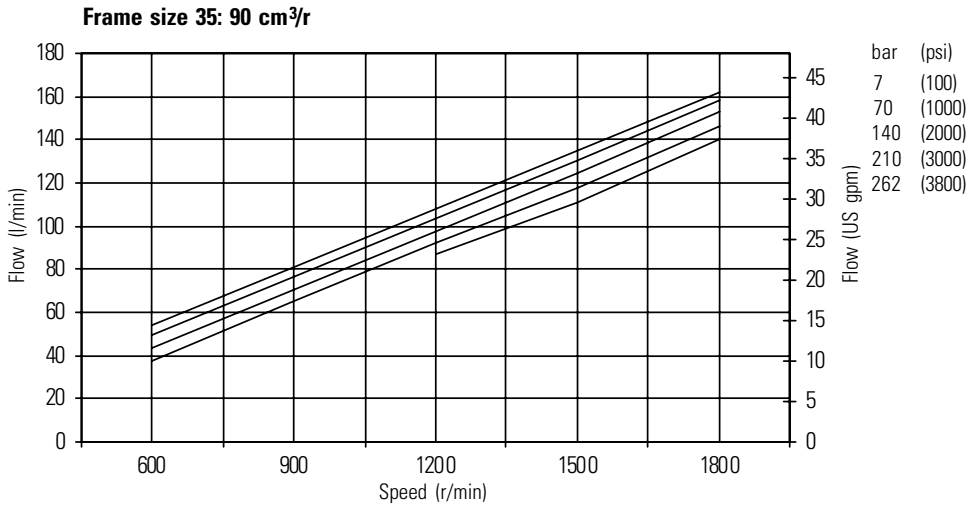
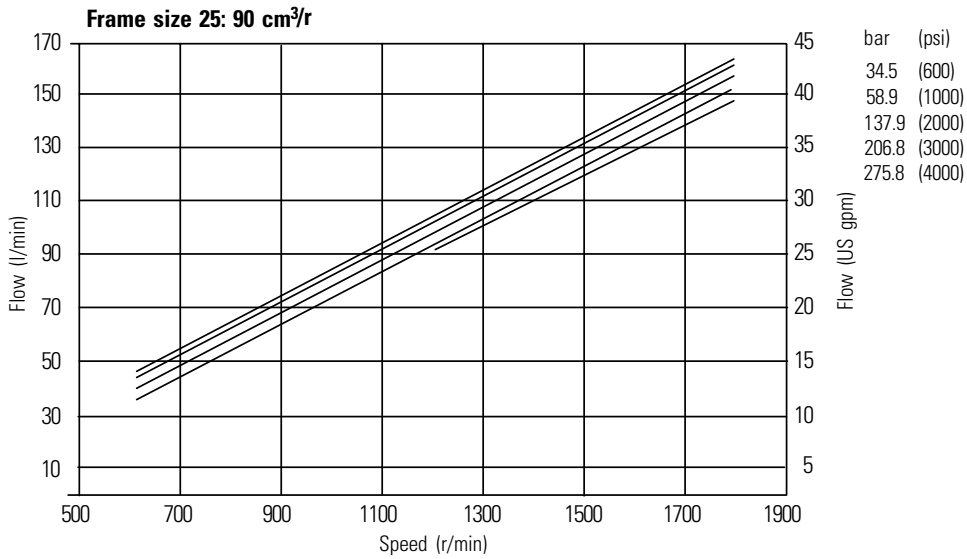
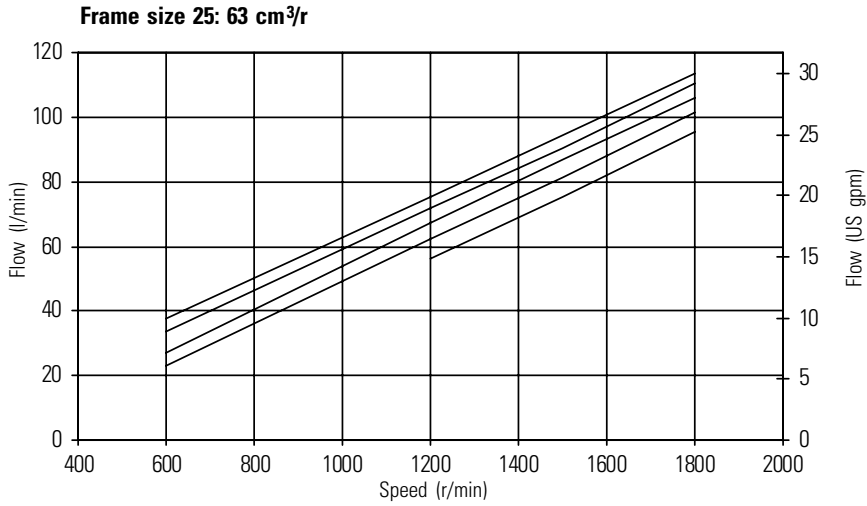

Typical Output Flow - Industrial (cont.)

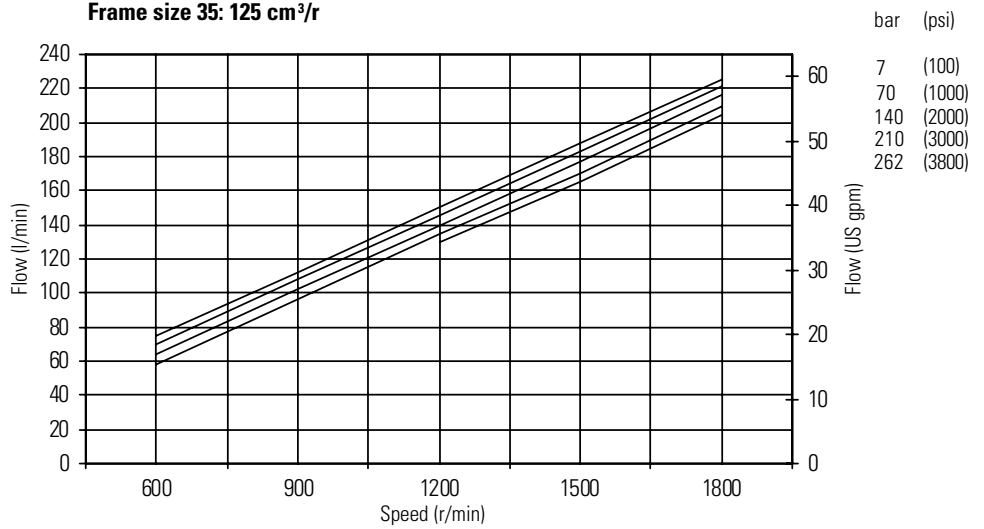
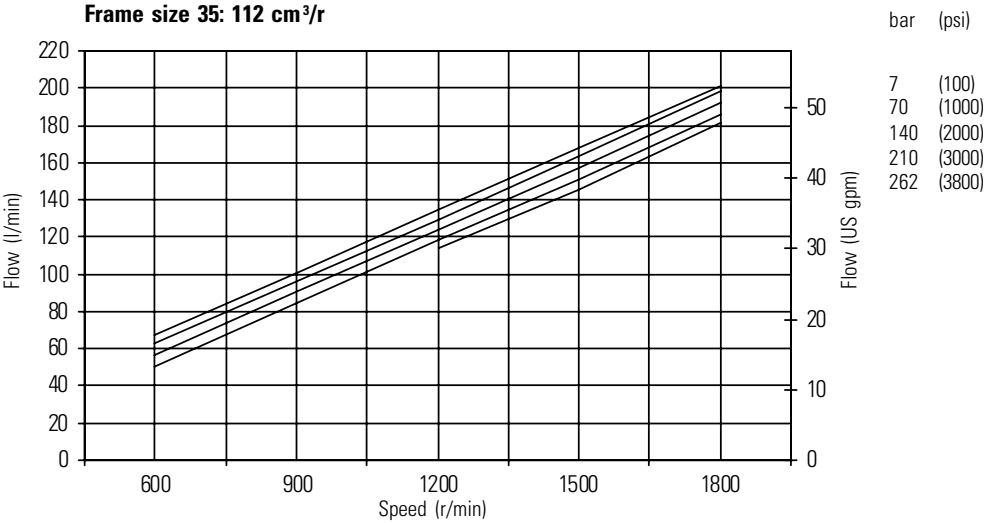
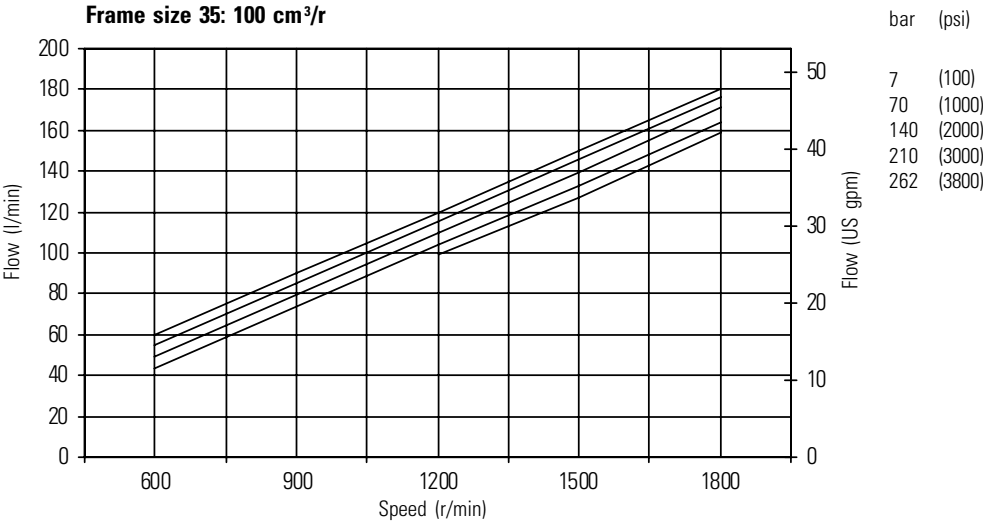

Typical Output Flow - Industrial (cont.)

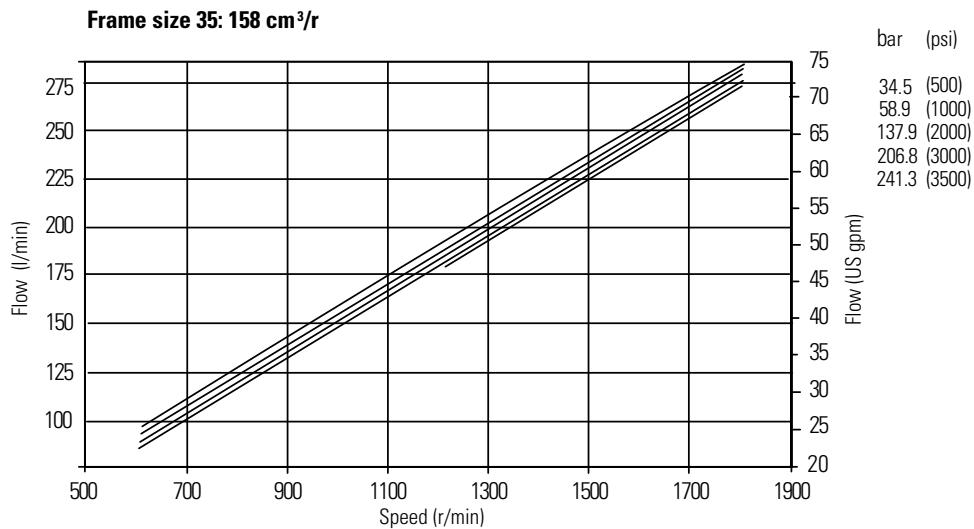
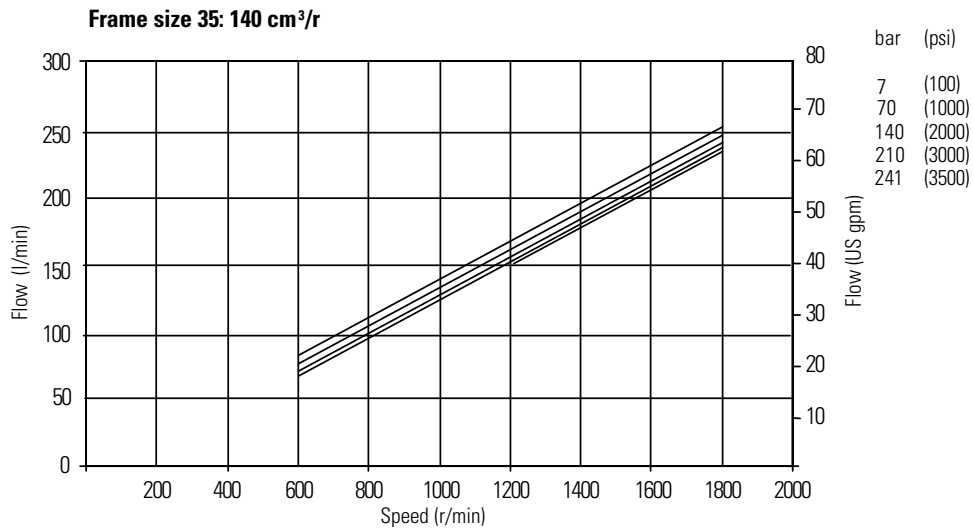
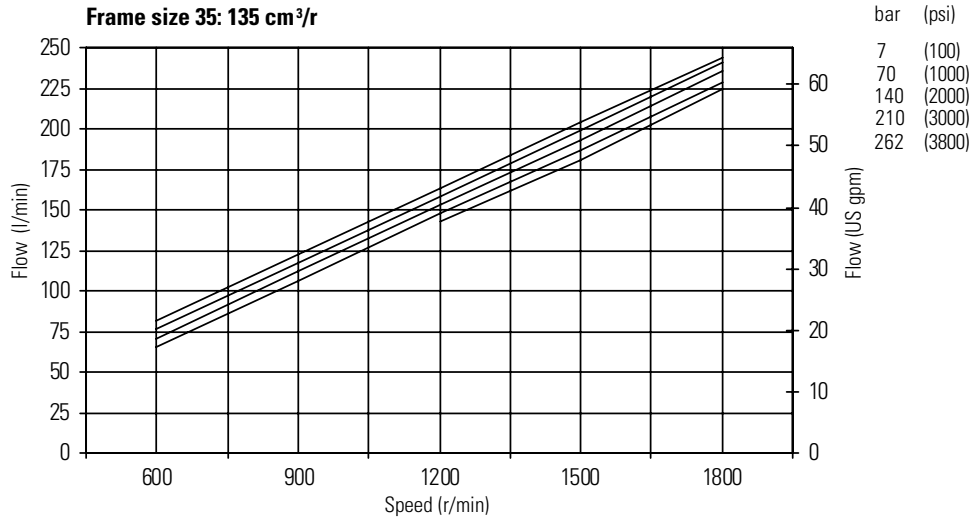

Typical Output Flow - Industrial (cont.)

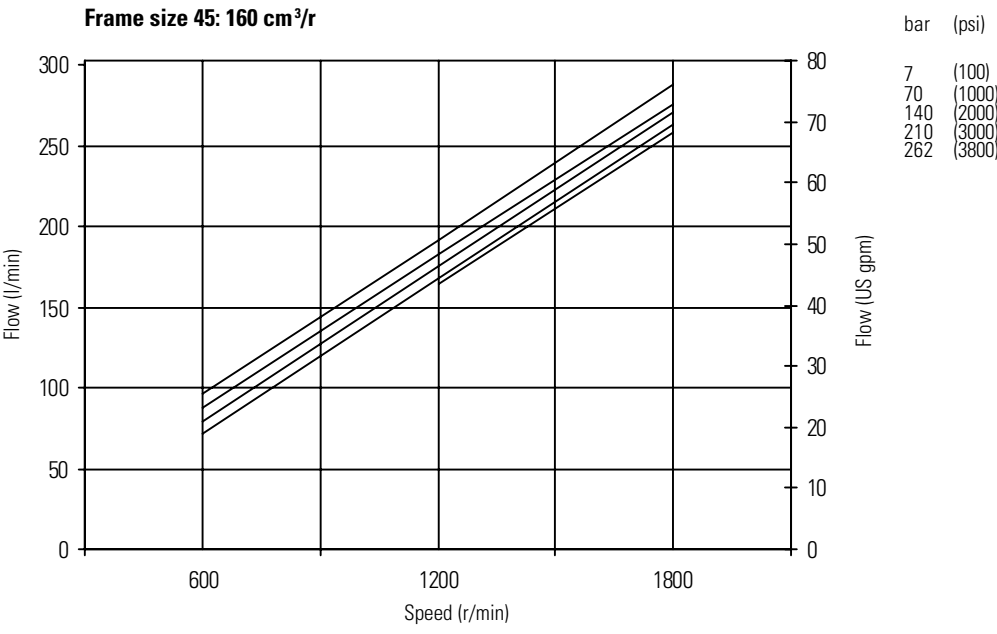
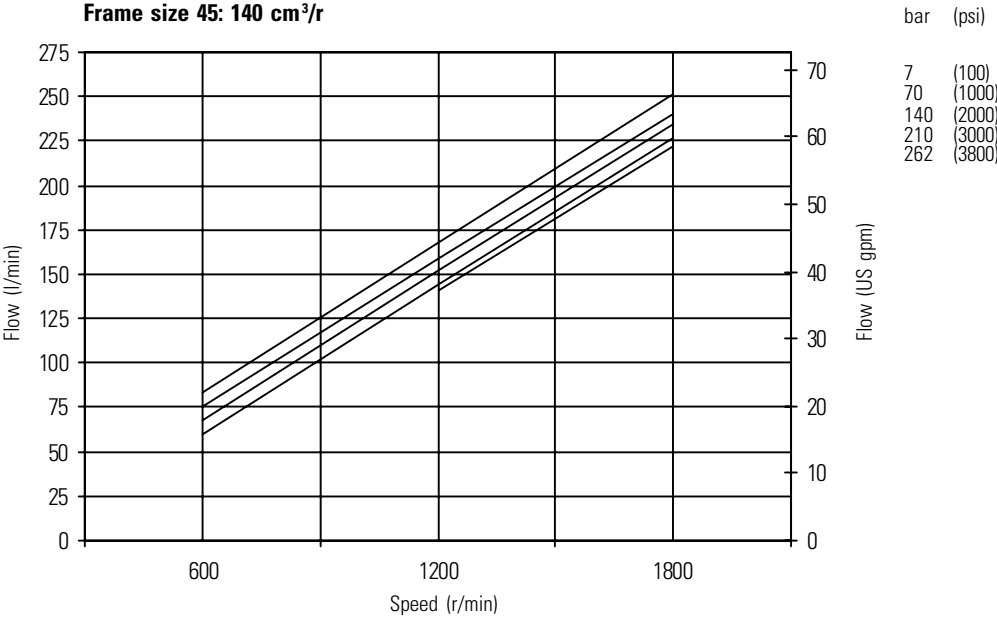

Typical Output Flow - Industrial (cont.)

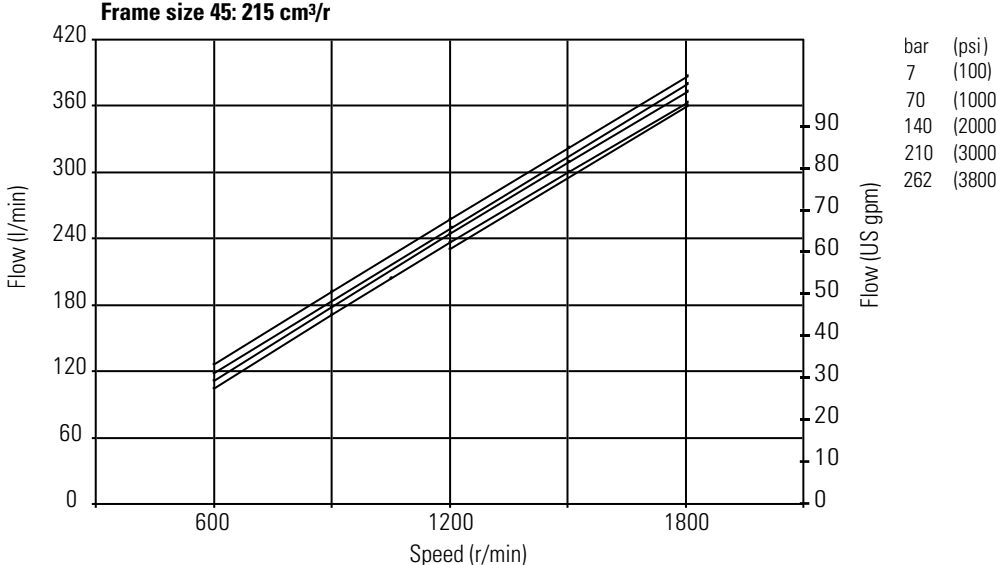
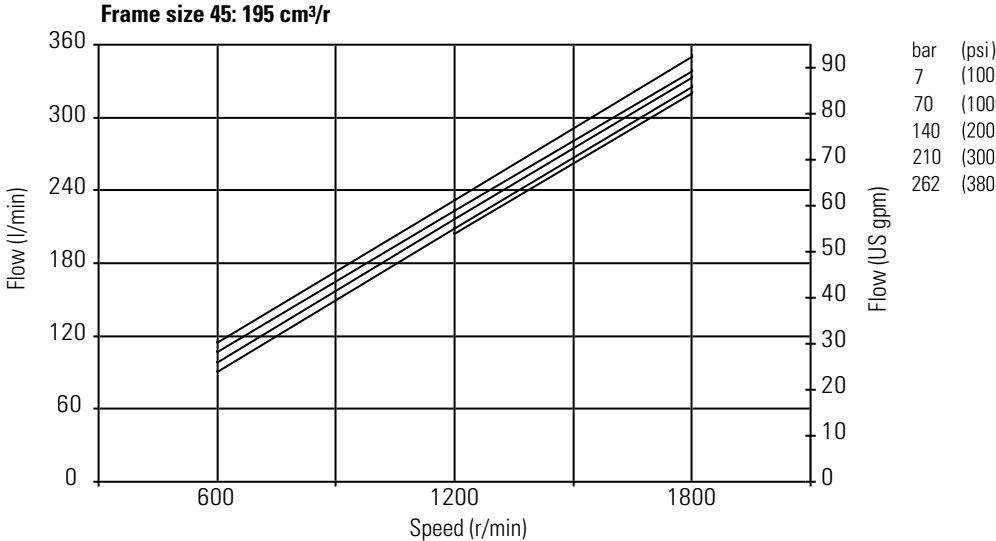
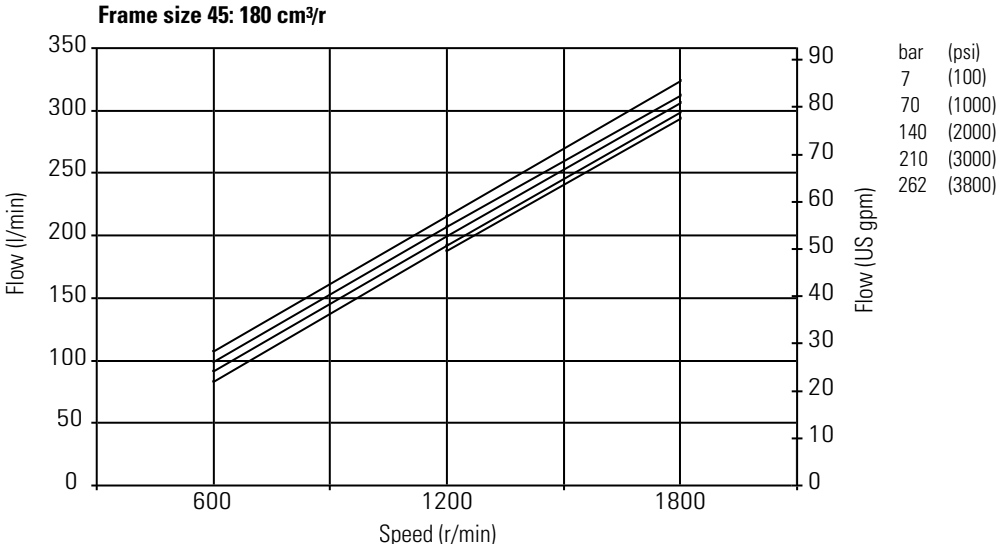

Typical Output Flow - Mobile

82°C (180°F), SAE 10W oil,
9 cSt (55 SUS)

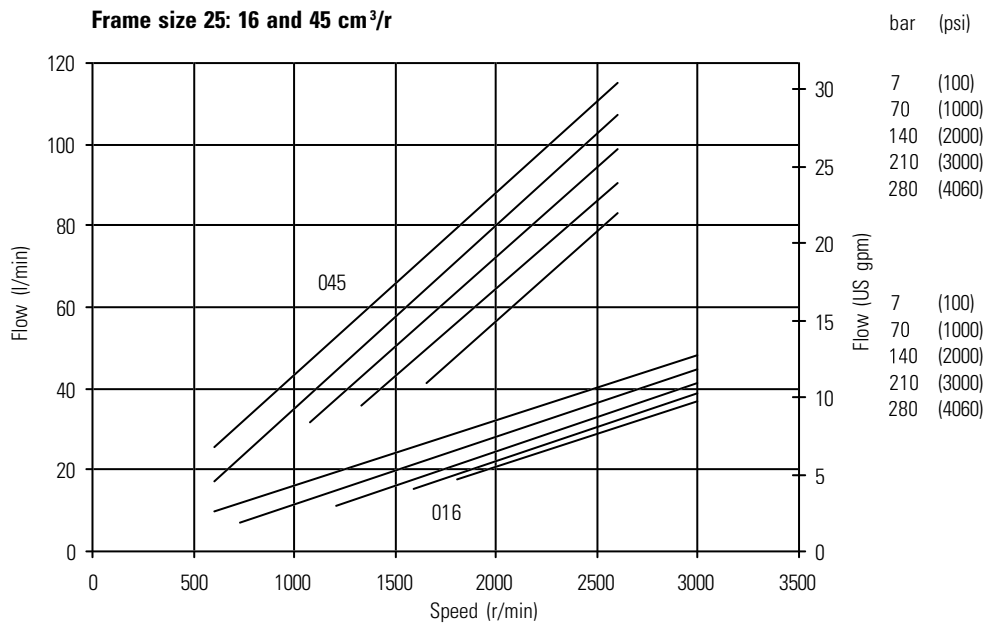
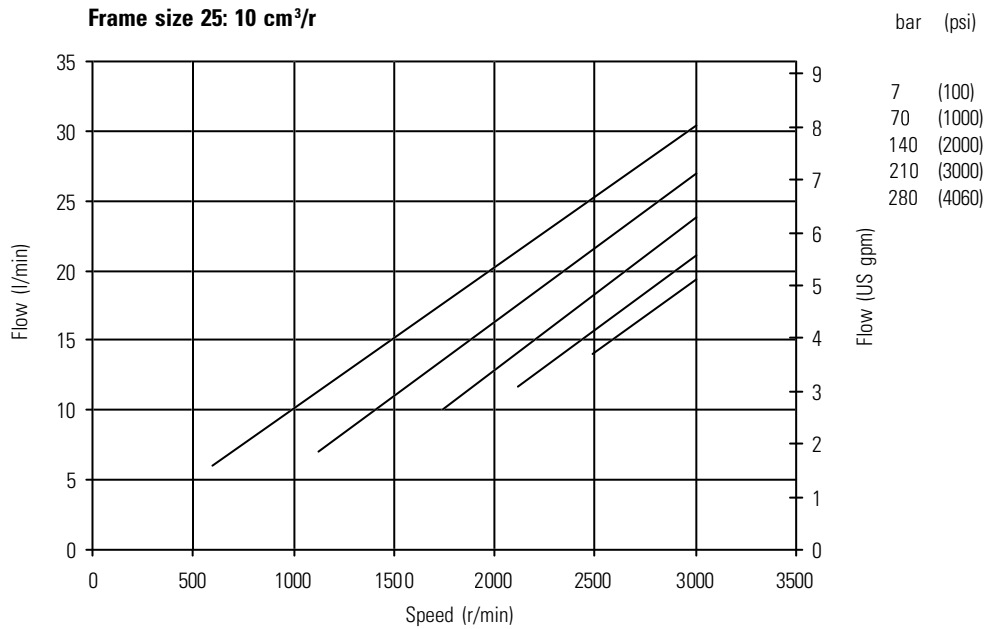

Typical Output Flow - Mobile (cont.)

Frame size 25: 20 and 50 cm³/r

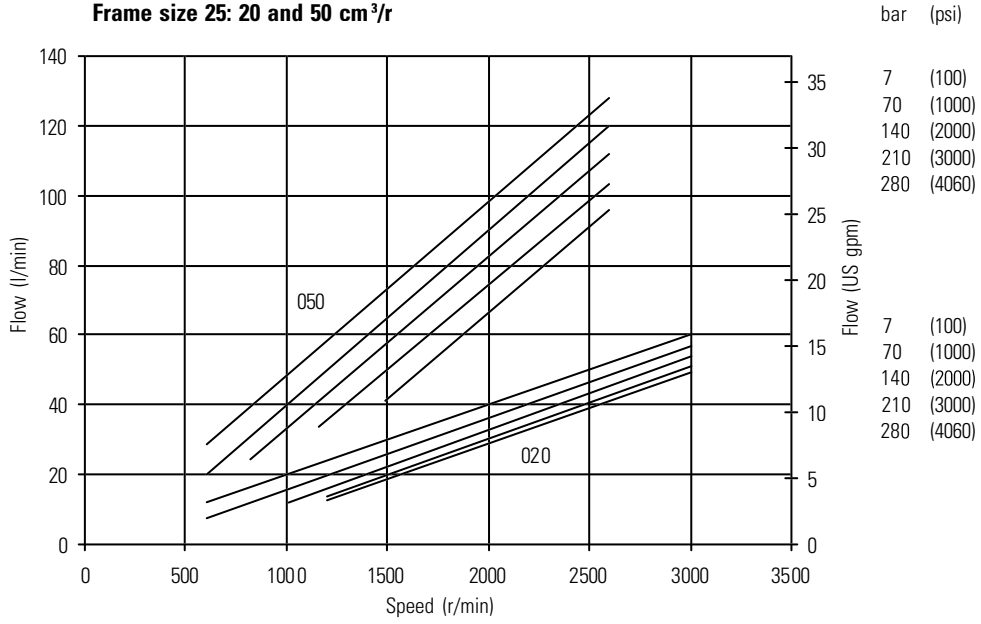

Frame size 25: 25 and 63 cm³/r

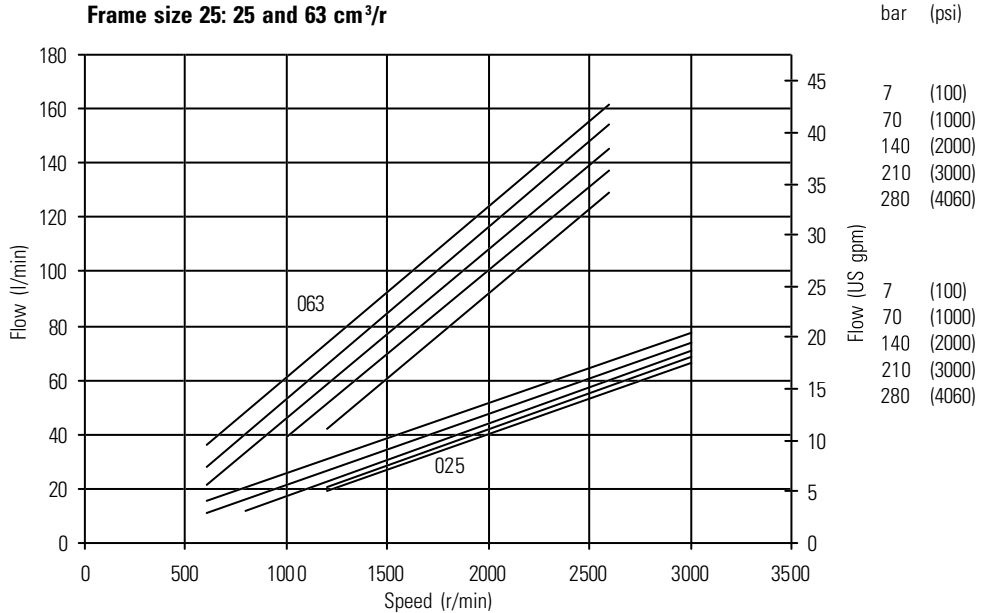

Typical Output Flow - Mobile (cont.)

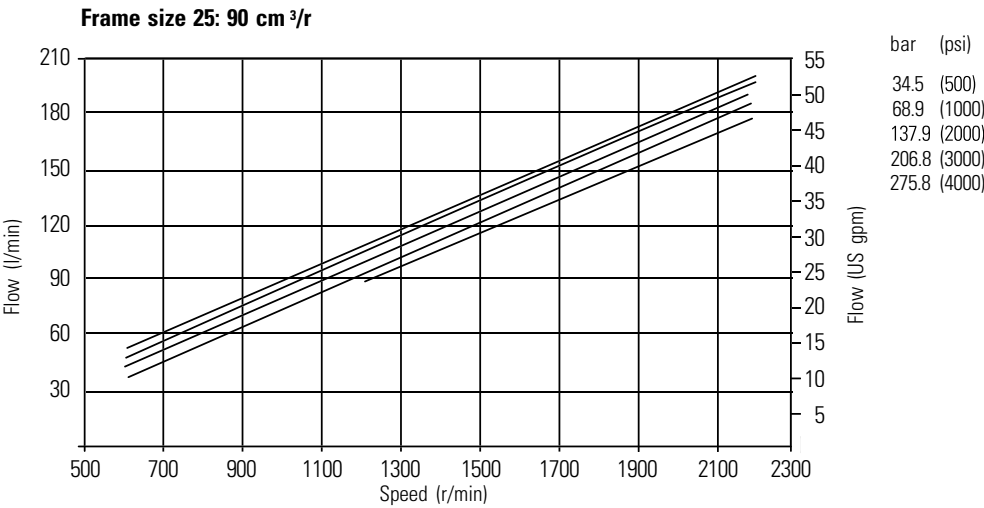
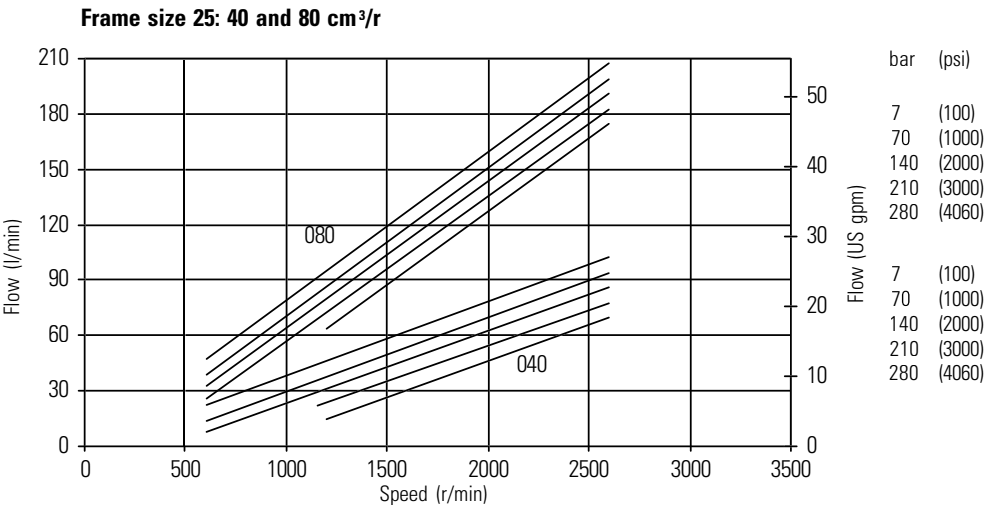
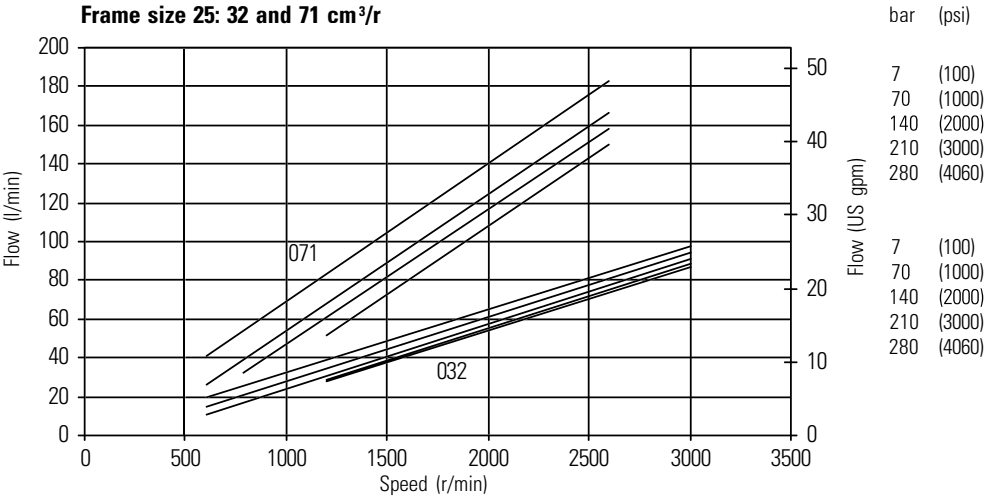

Typical Output Flow - Mobile (cont.)

Frame size 35: 90 cm³/r

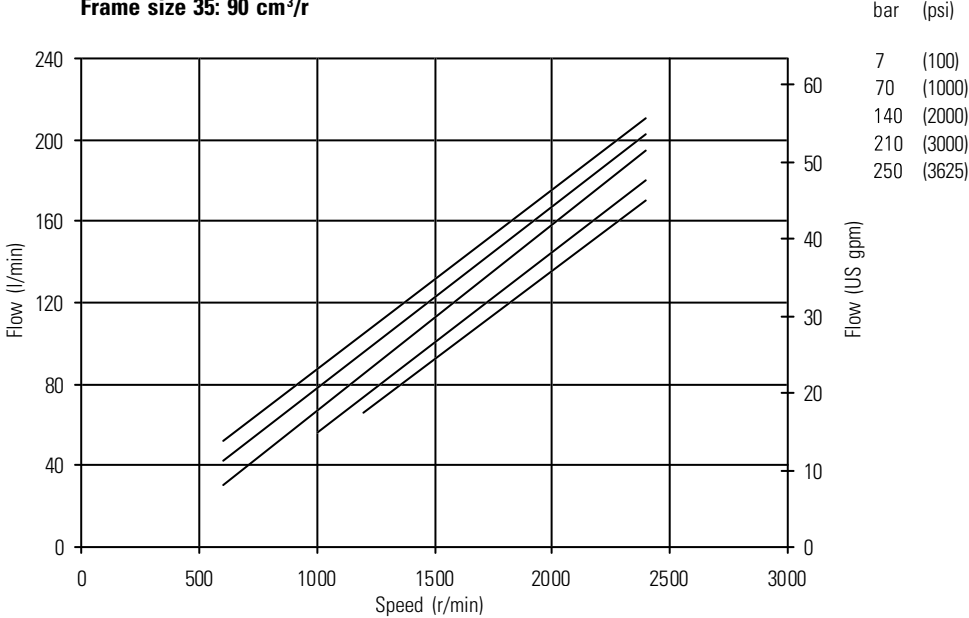

Frame size 35: 100 cm³/r

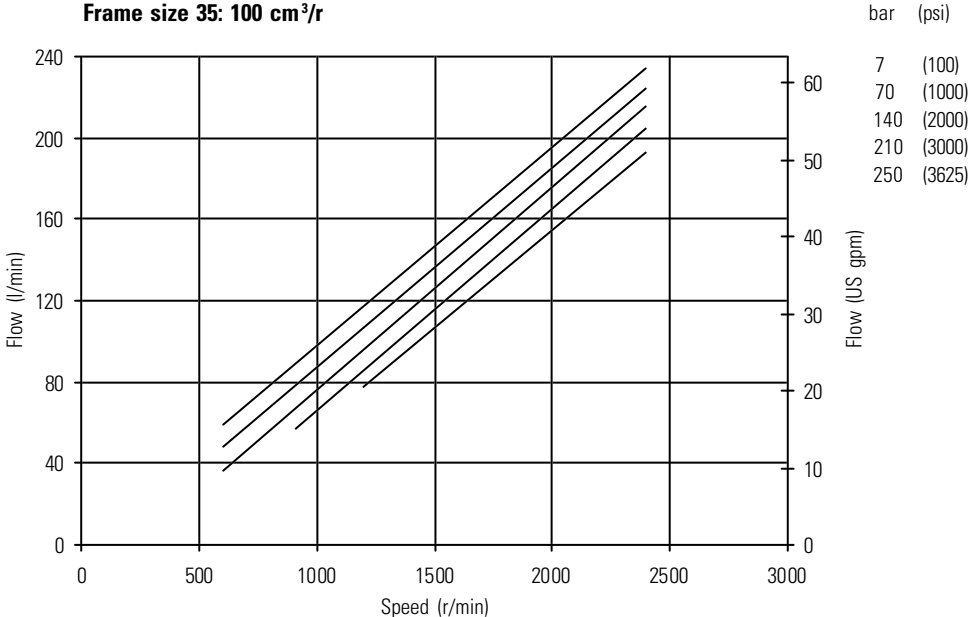

Typical Output Flow - Mobile (cont.)

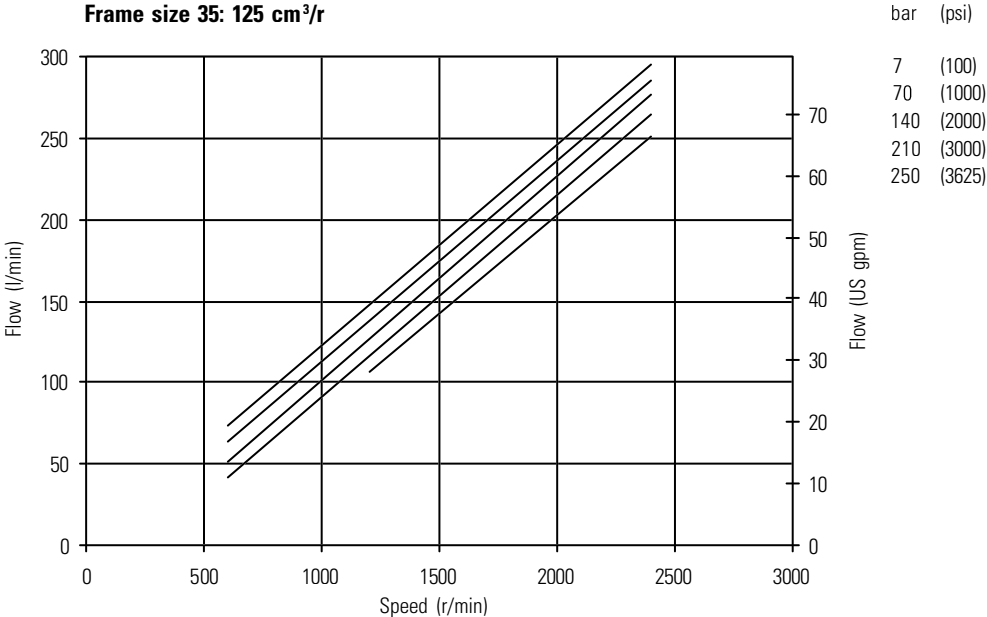
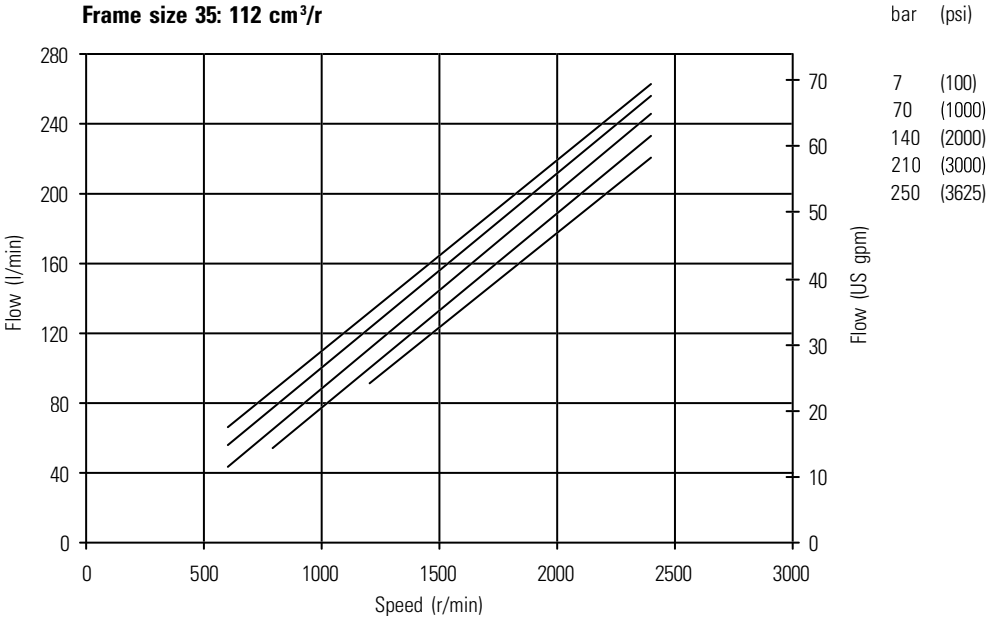

Typical Output Flow - Mobile (cont.)

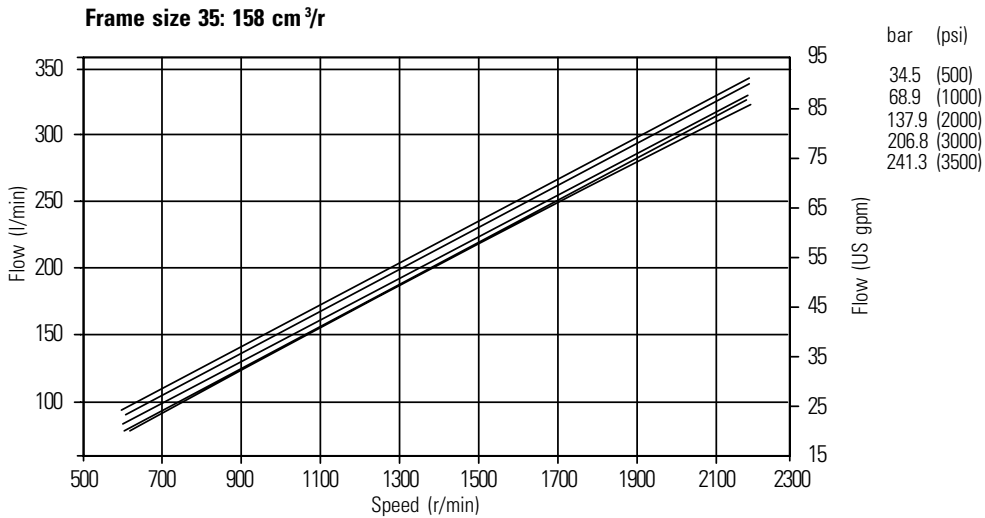
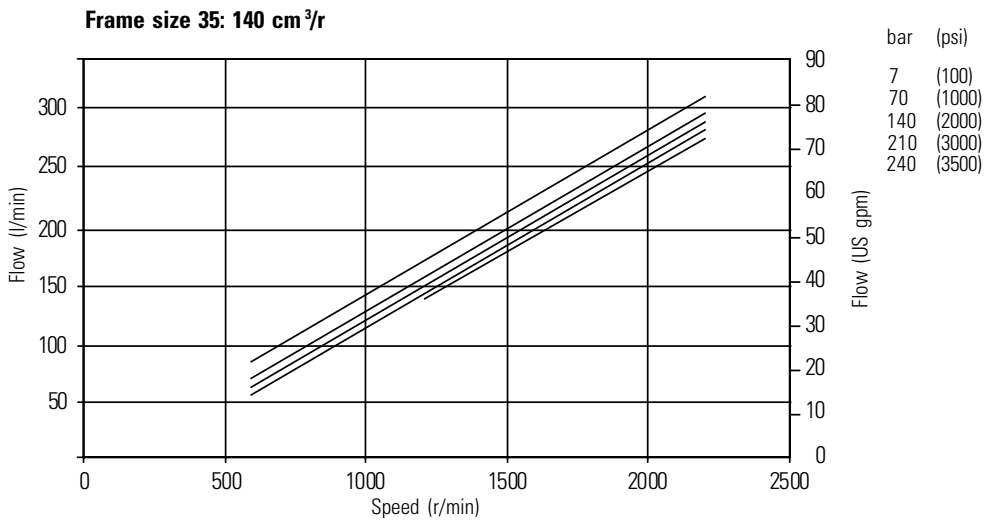
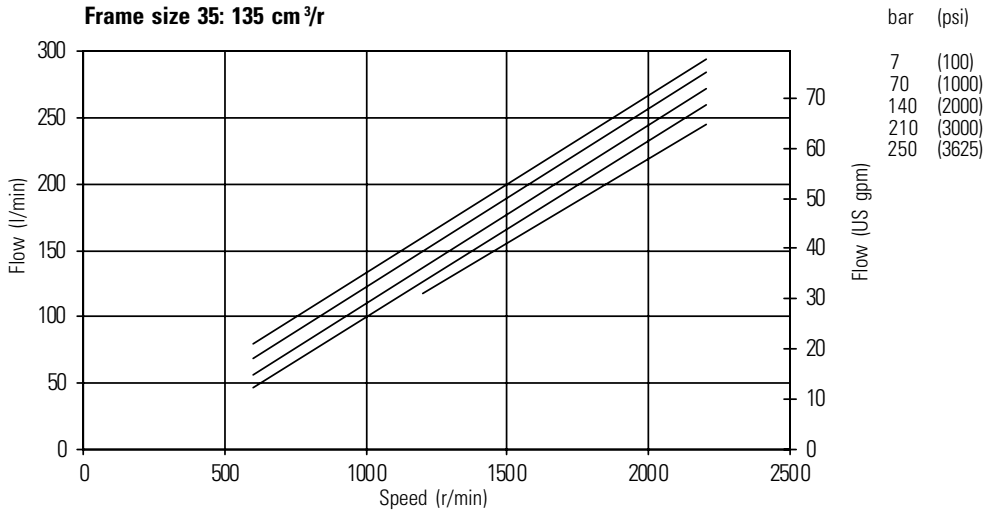

Typical Output Flow - Mobile (cont.)

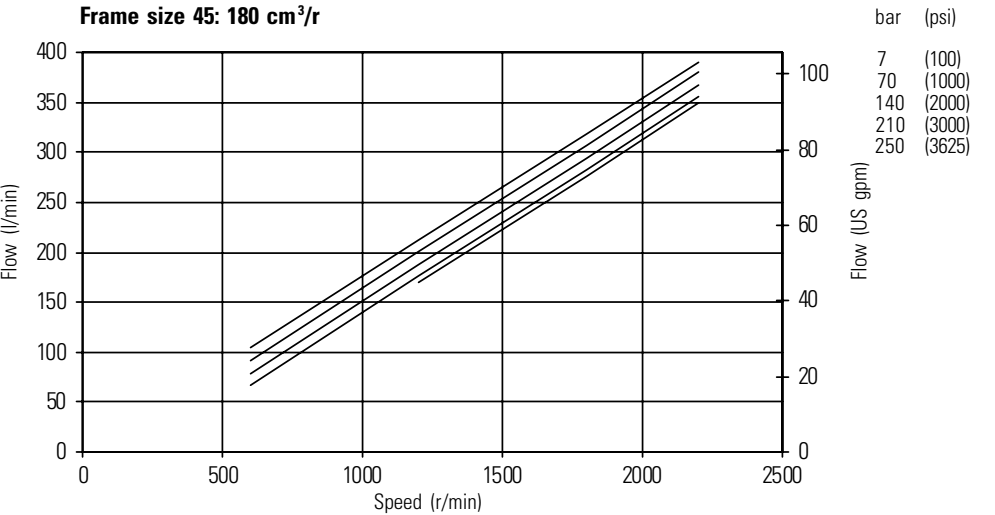
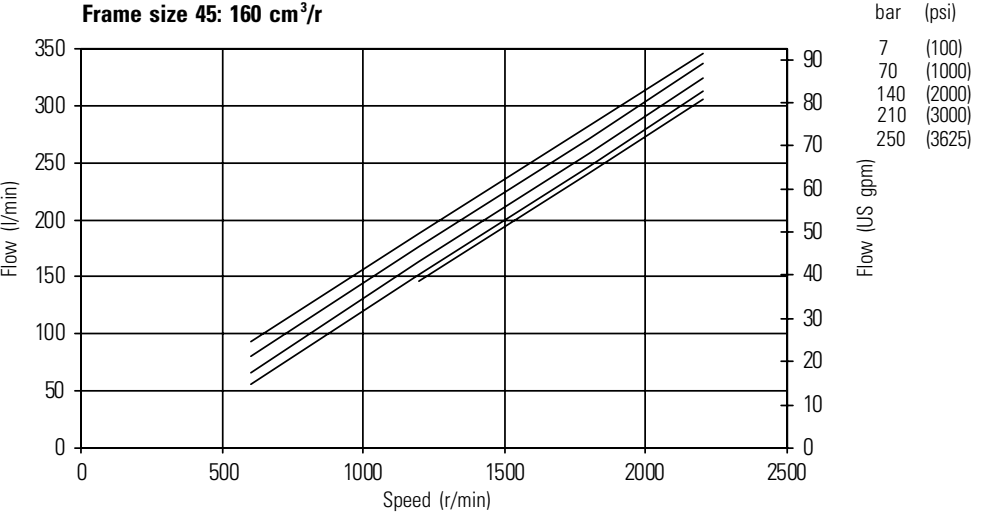
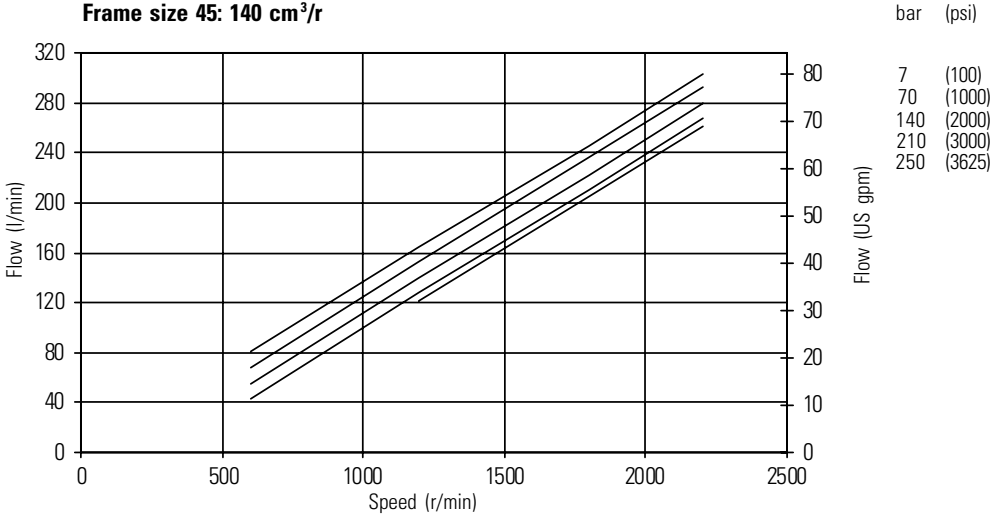

Typical Output Flow - Mobile (cont.)

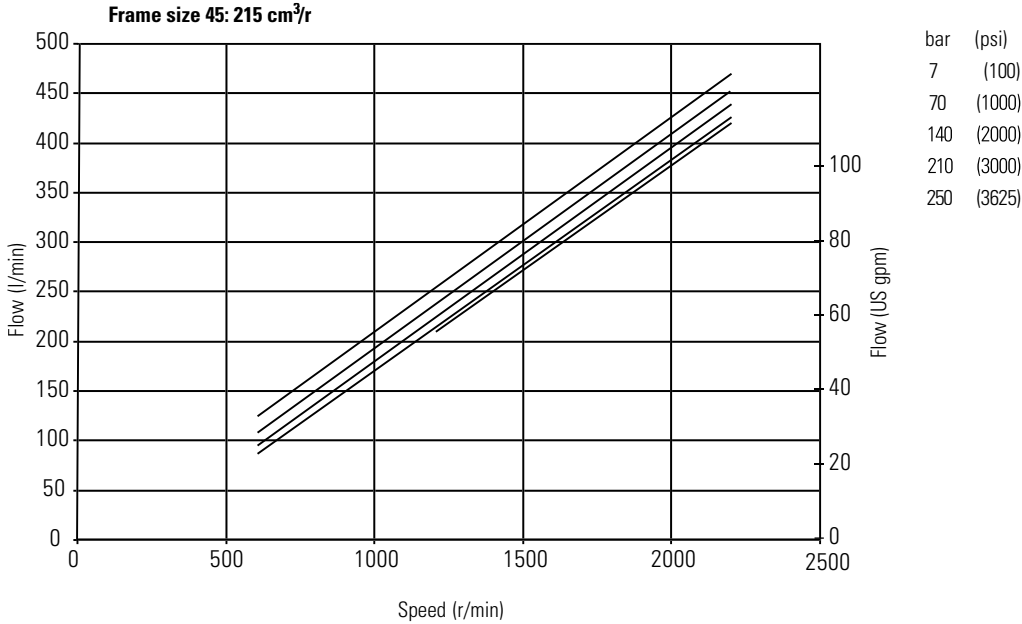
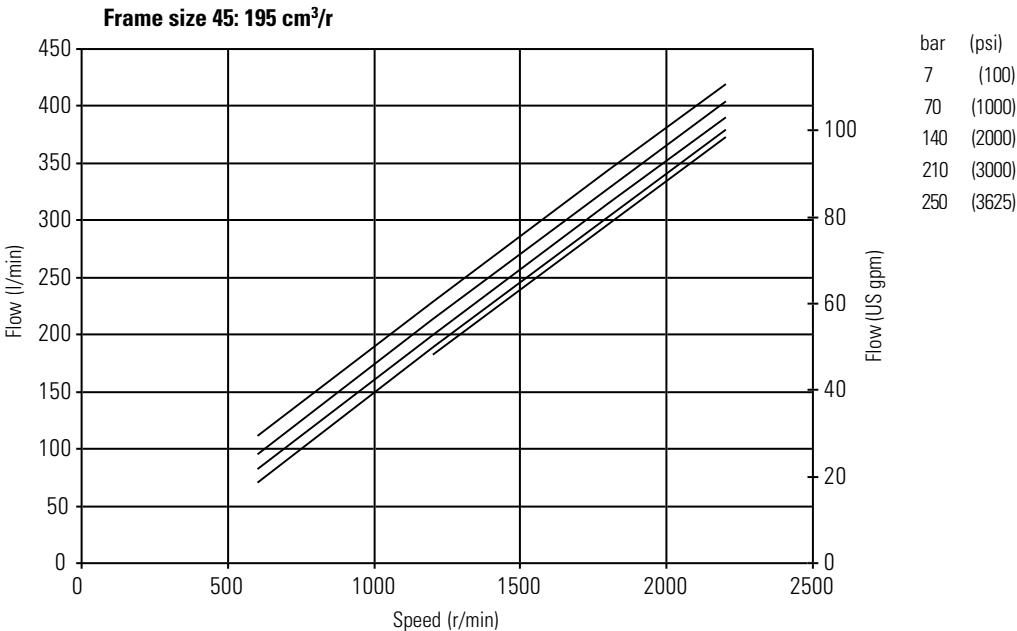

Typical Input Power - Industrial

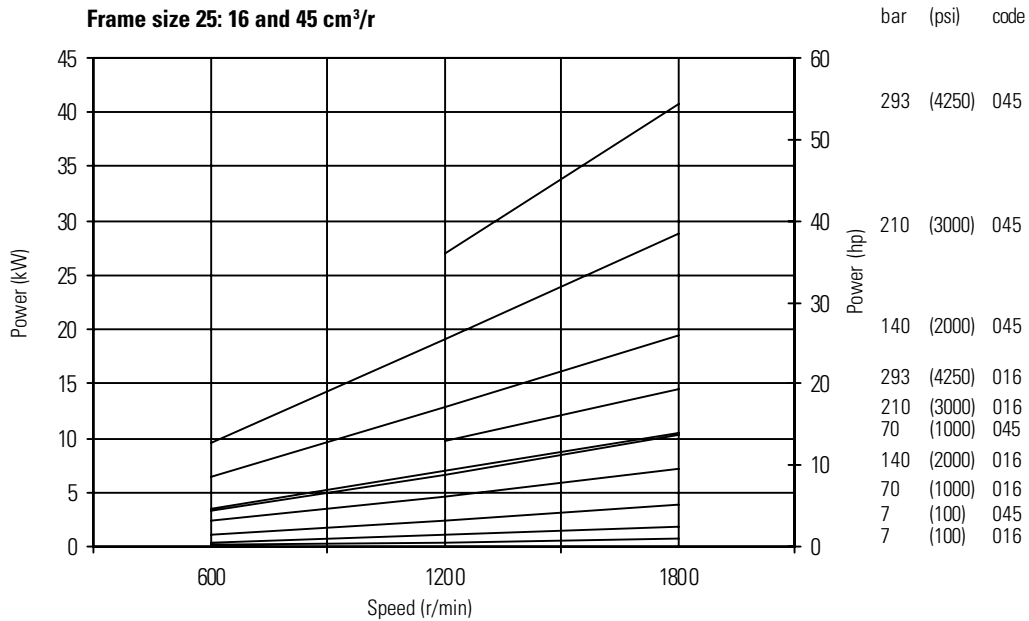
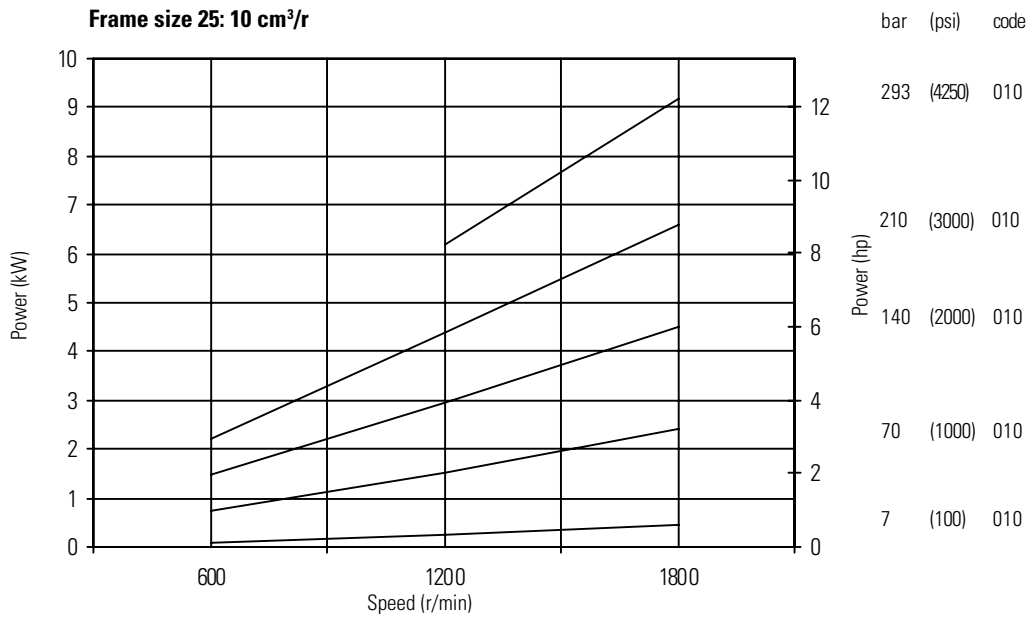

Typical Input Power - Industrial (cont.)

Frame 25: 20 and 50 cm³/r

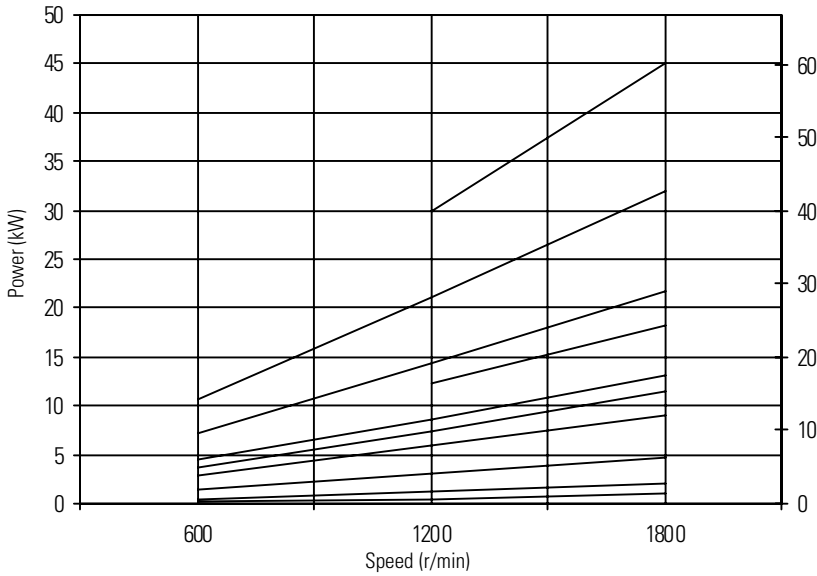

bar	(psi)	code
293	(4250)	050
210	(3000)	050
140	(2000)	050
293	(4250)	020
210	(3000)	020
70	(1000)	050
140	(2000)	020
70	(1000)	020
7	(100)	050
7	(100)	020

Frame size 25: 25 and 63 cm³/r

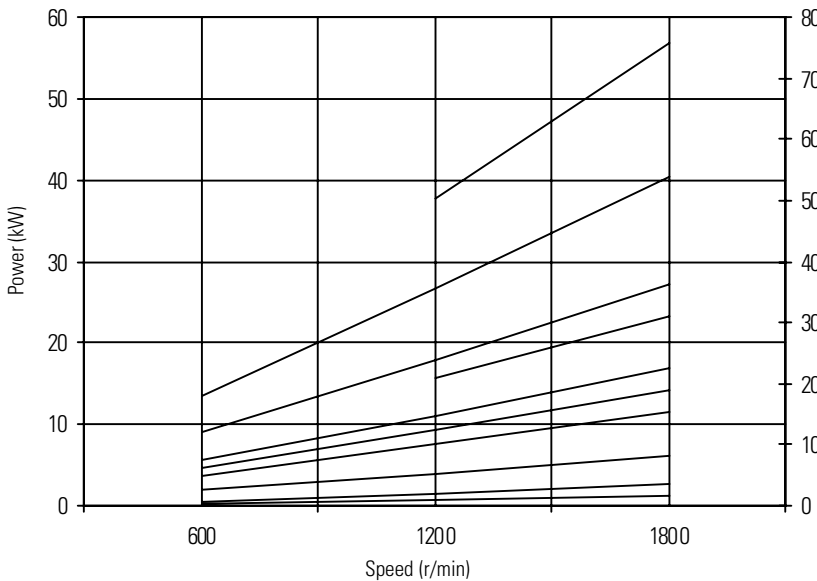

bar	(psi)	code
293	(4250)	063
210	(3000)	063
140	(2000)	063
293	(4250)	025
210	(3000)	025
70	(1000)	063
140	(2000)	025
70	(1000)	025
7	(100)	063
7	(100)	025

Typical Input Power - Industrial (cont.)

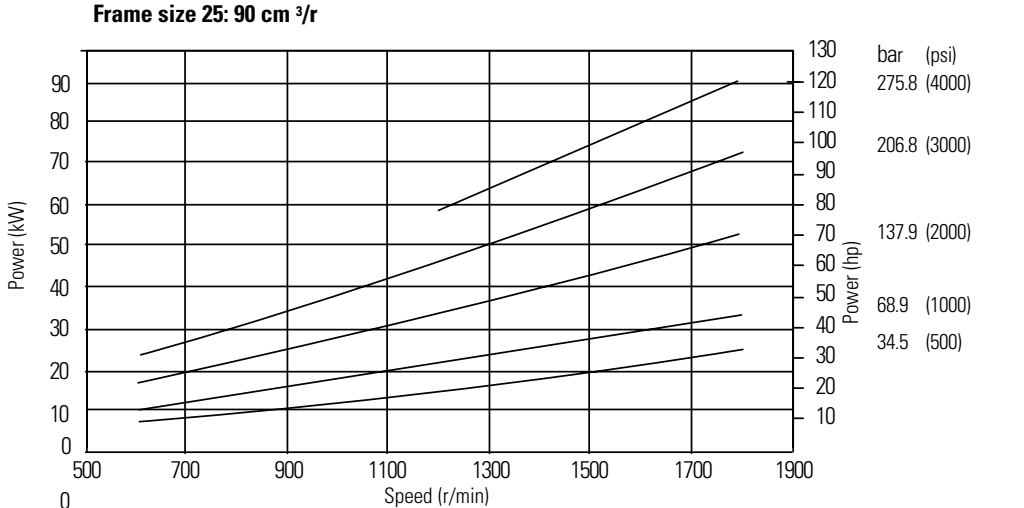
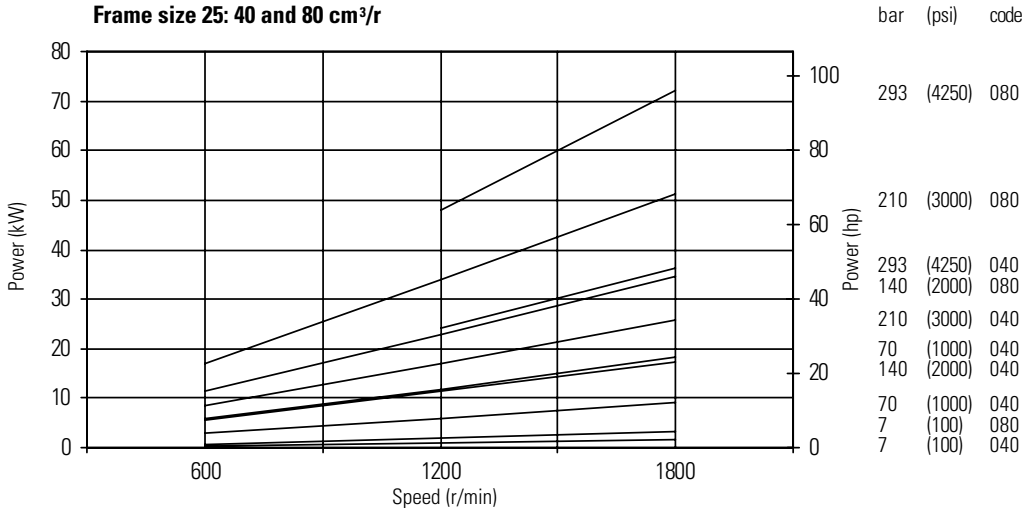
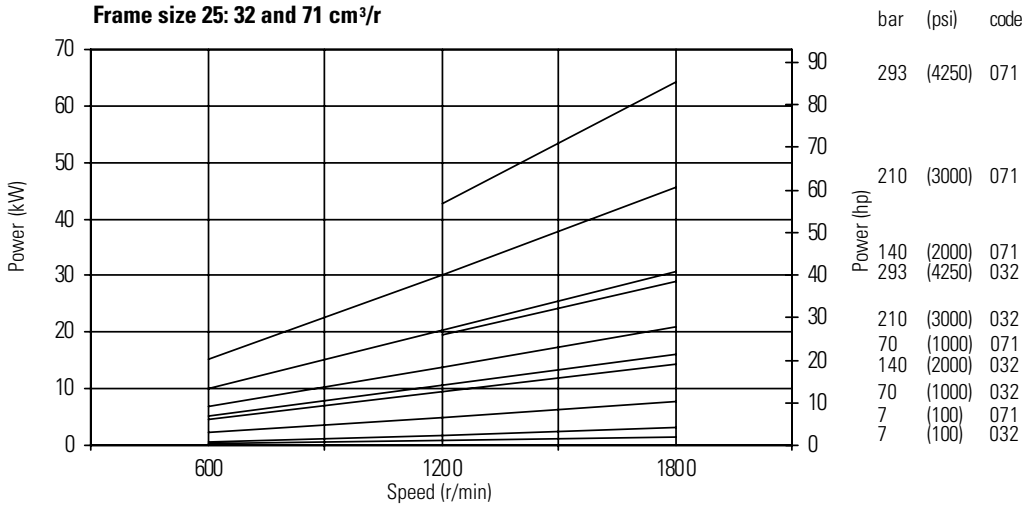

Typical Input Power -Industrial (cont.)

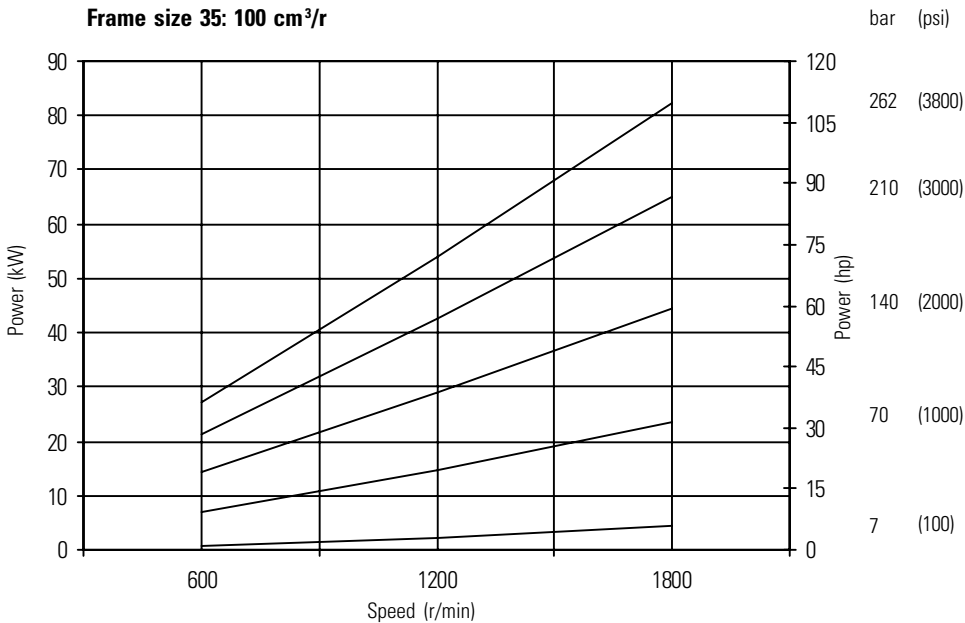
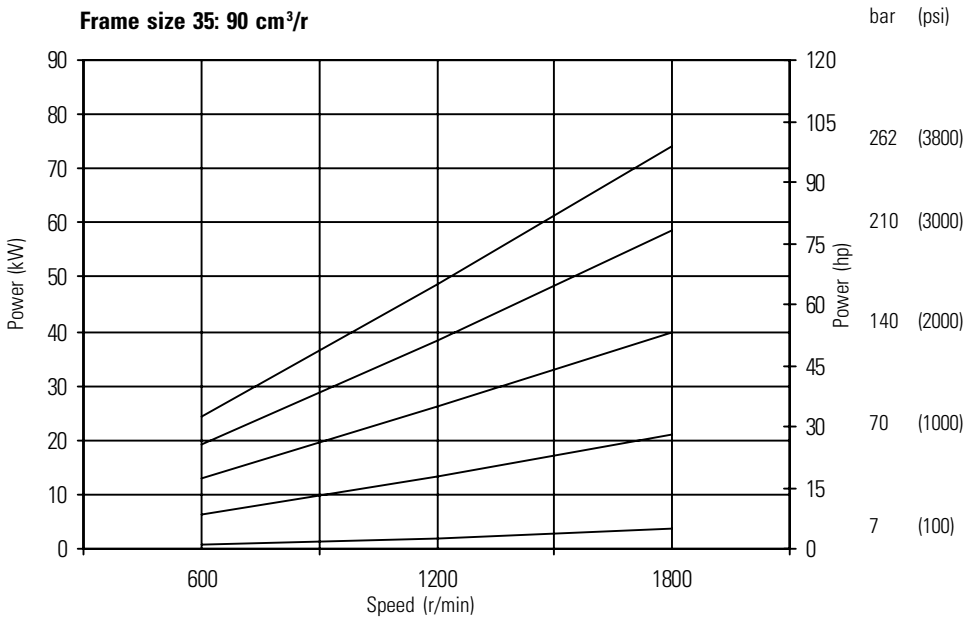

Typical Input Power - Industrial (cont.)

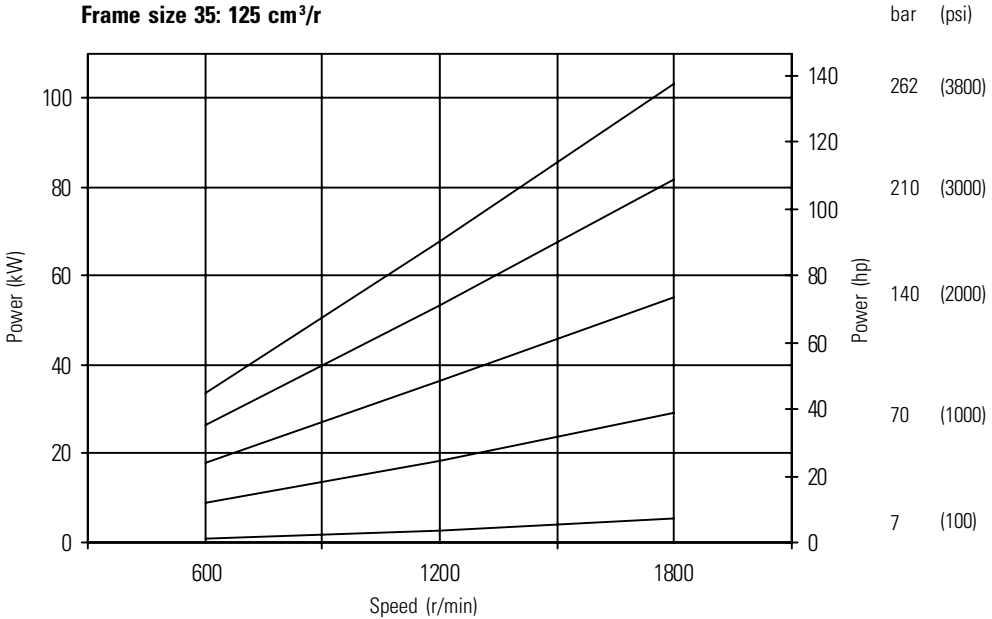
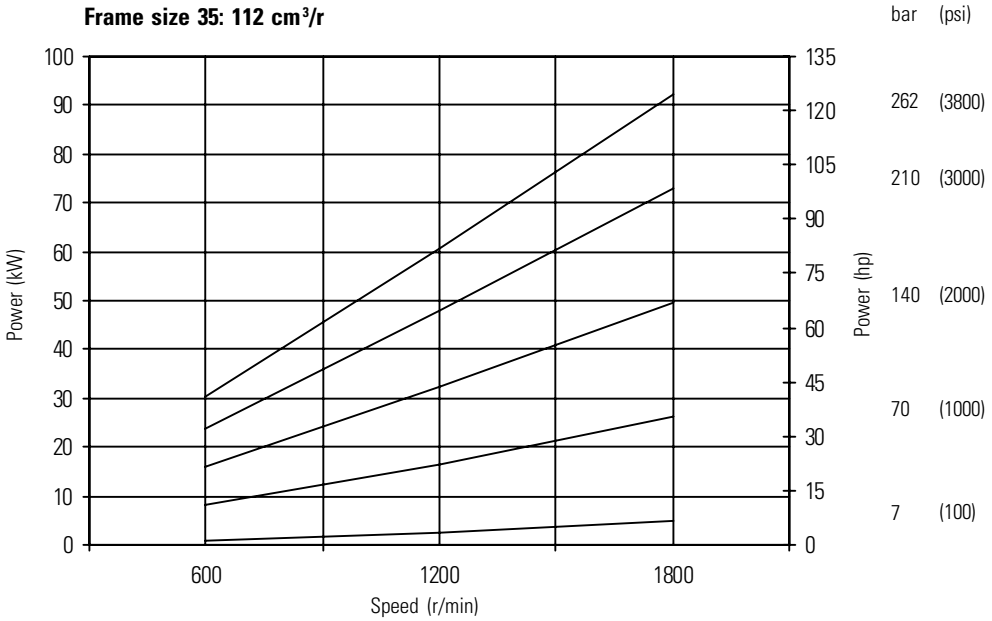

Typical Input Power - Industrial (cont.)

Frame size 35: 135 cm³/r

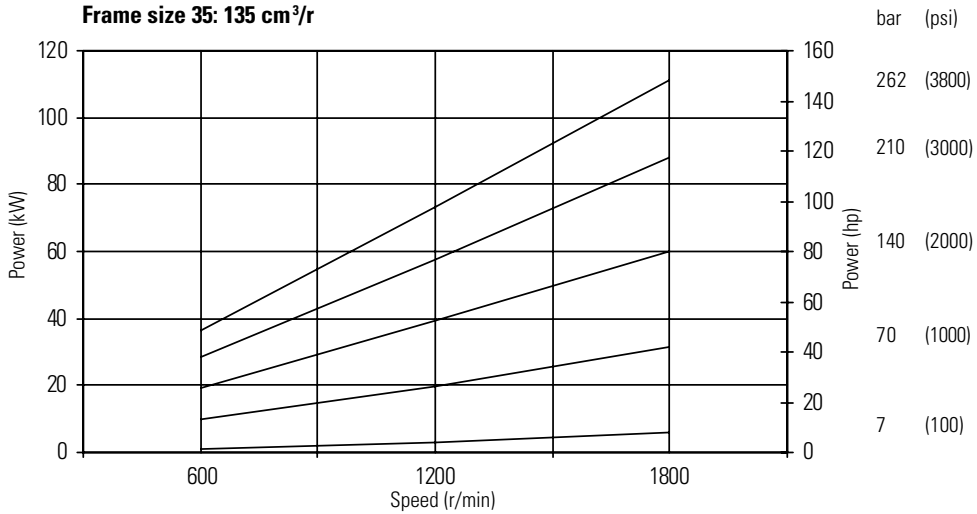

Frame size 35: 140 cm³/r

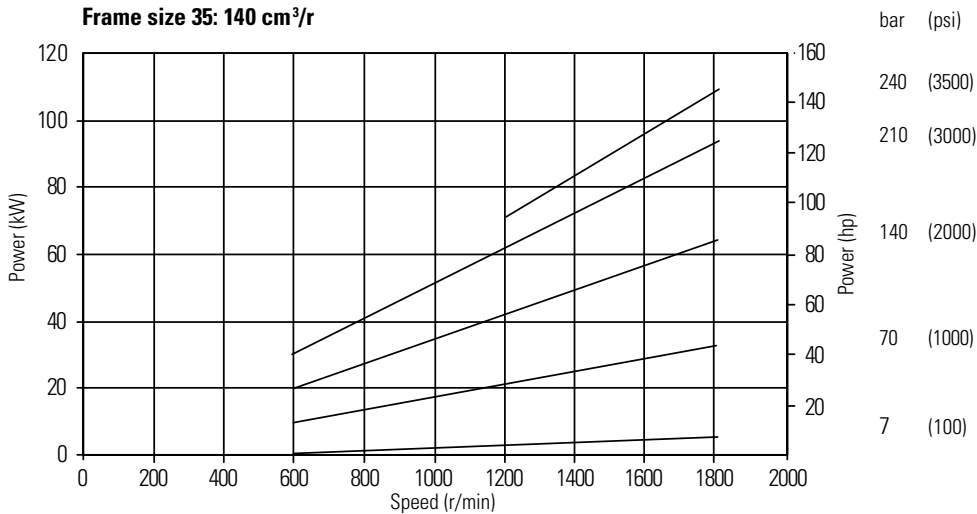

Frame size 35: 158 cm³/r

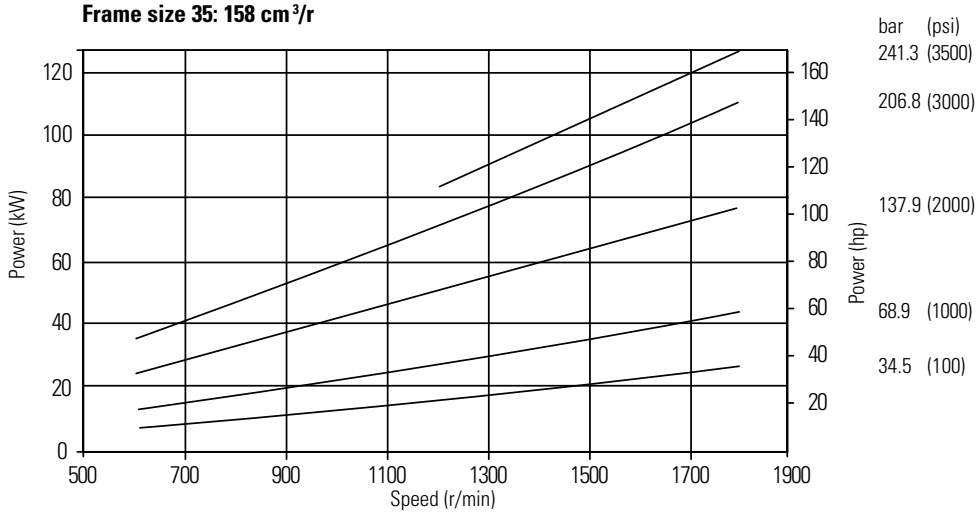

Typical Input Power - Industrial (cont.)

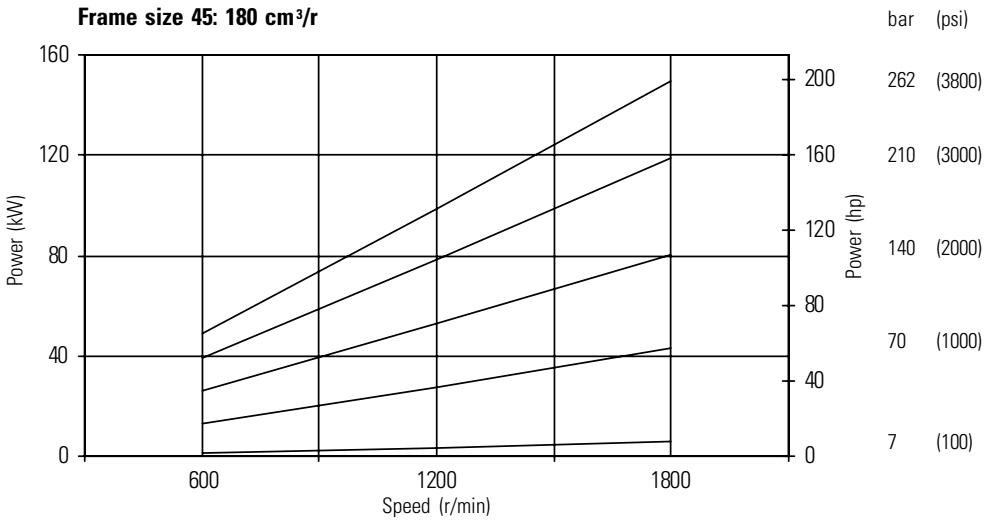
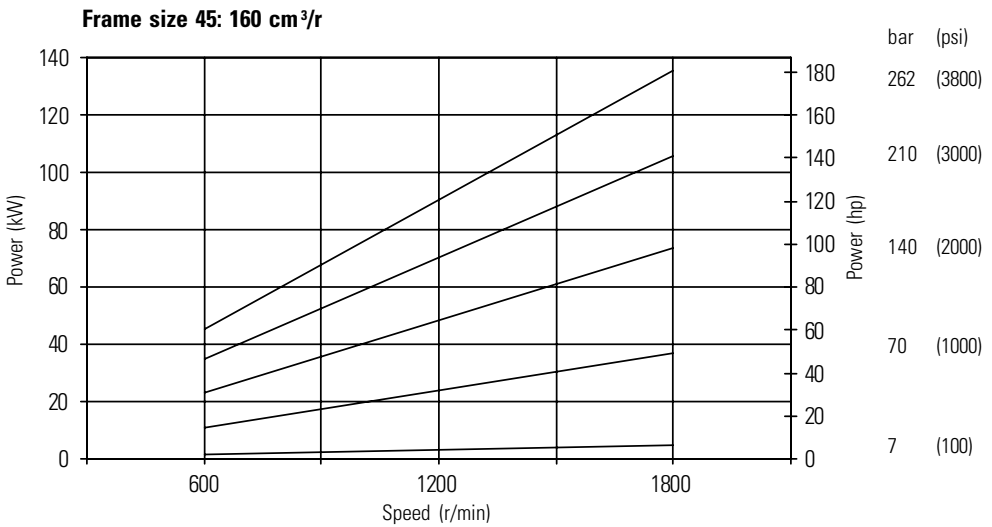
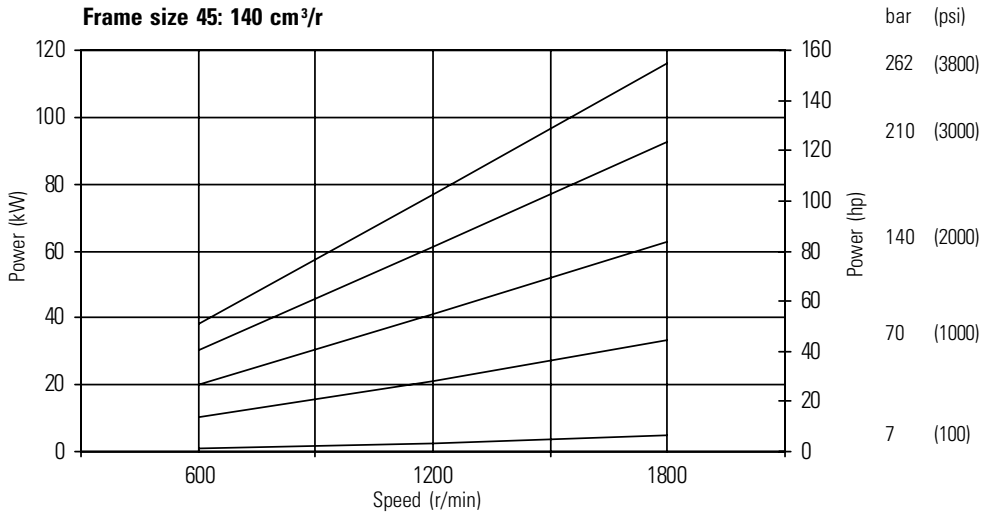

Typical Input Power - Industrial (cont.)

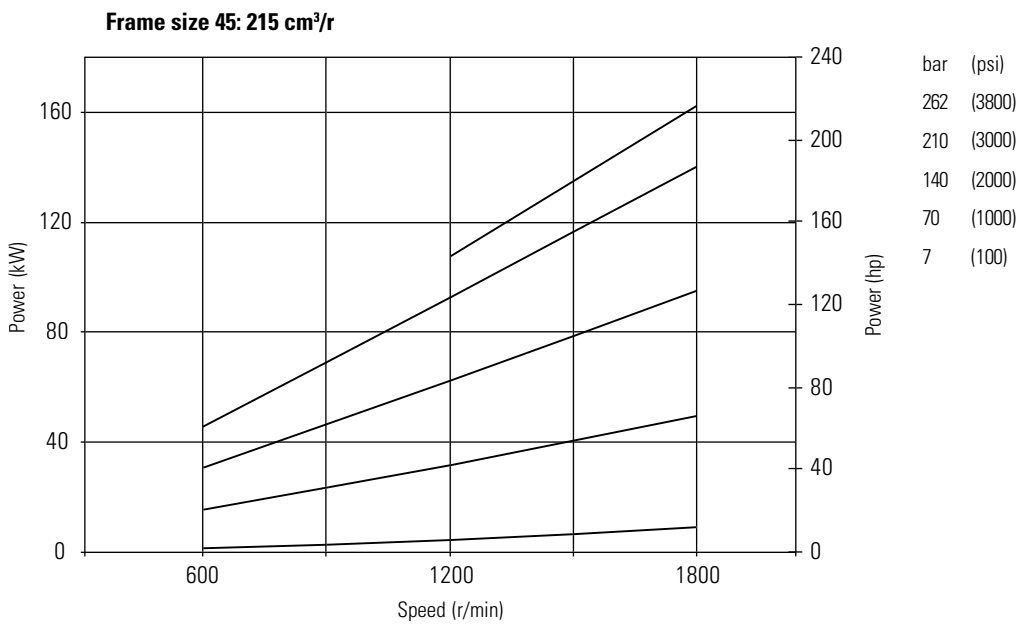
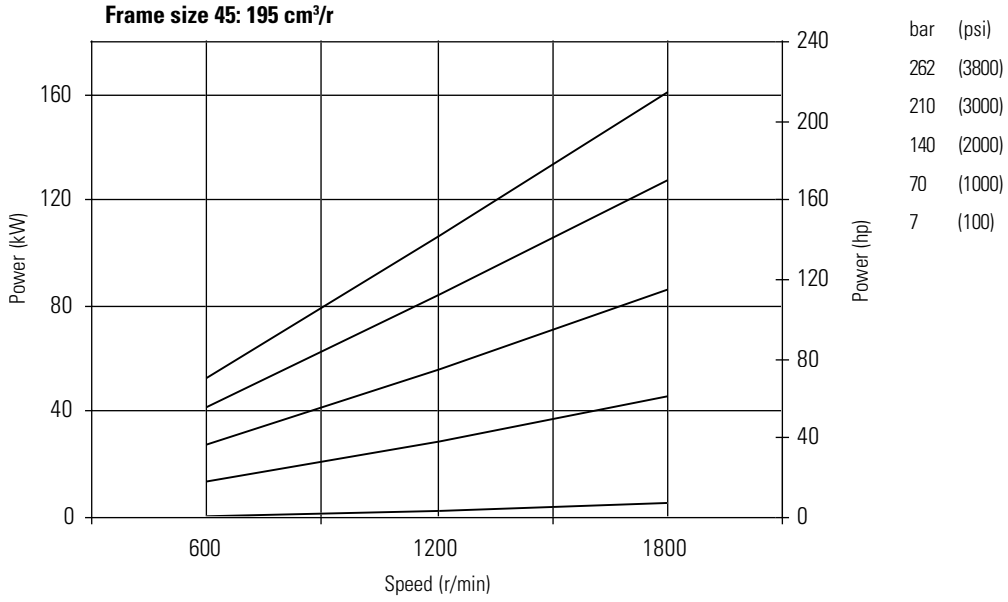

Typical Input Power - Mobile

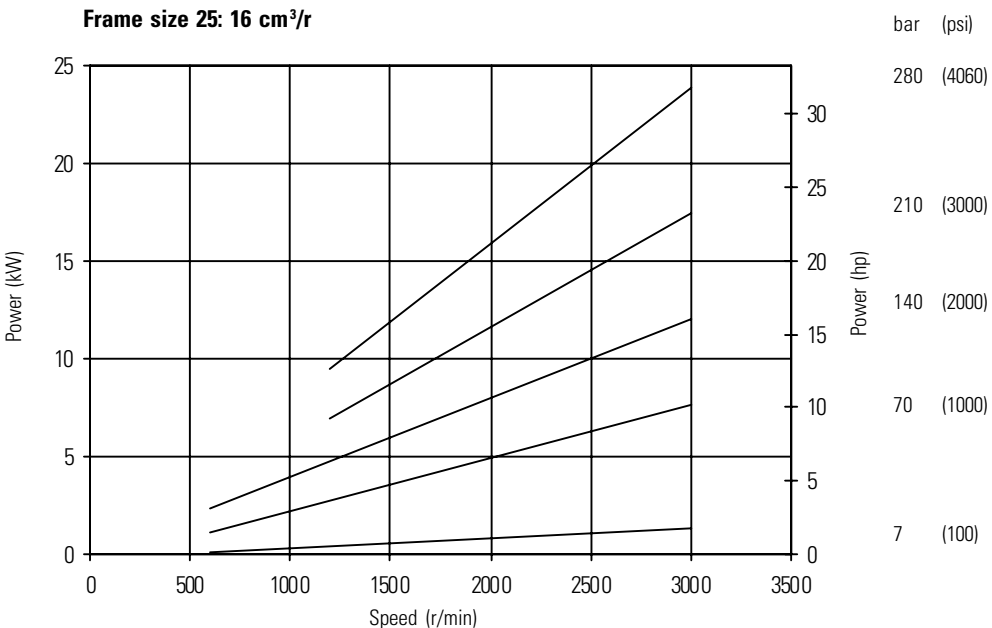
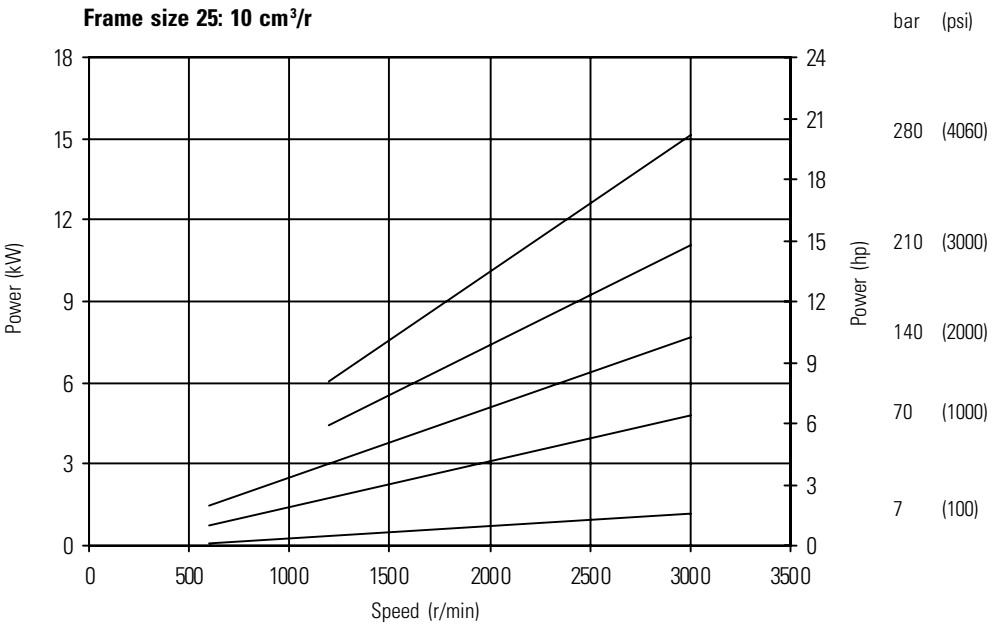

Typical Input Power - Mobile (cont.)

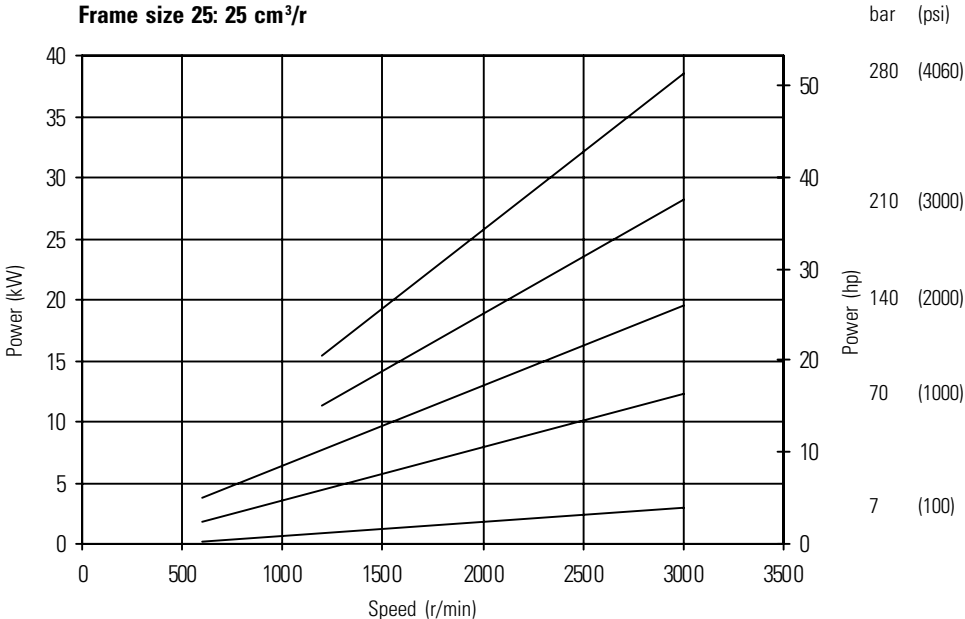
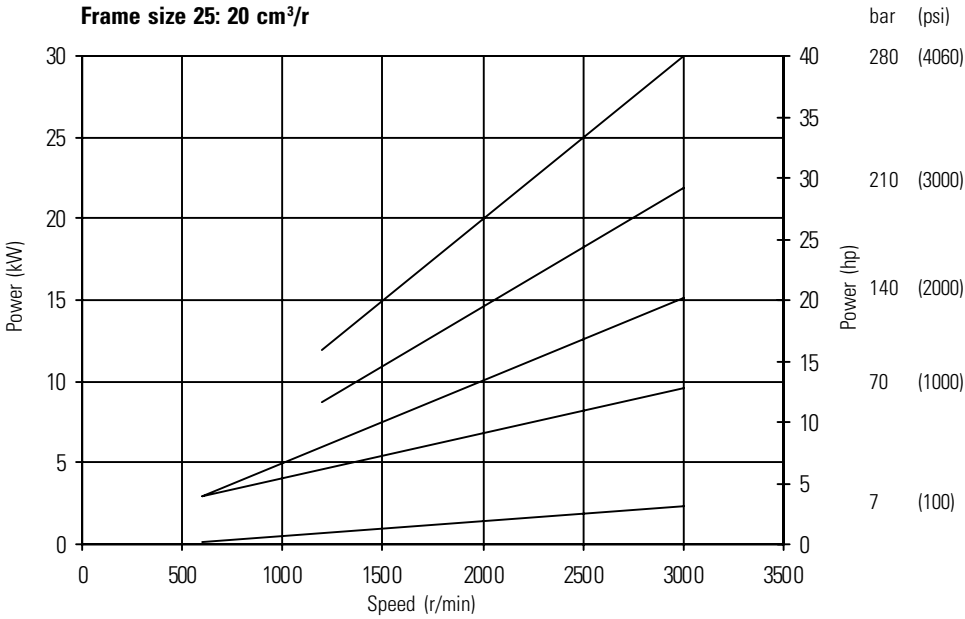

Typical Input Power - Mobile (cont.)

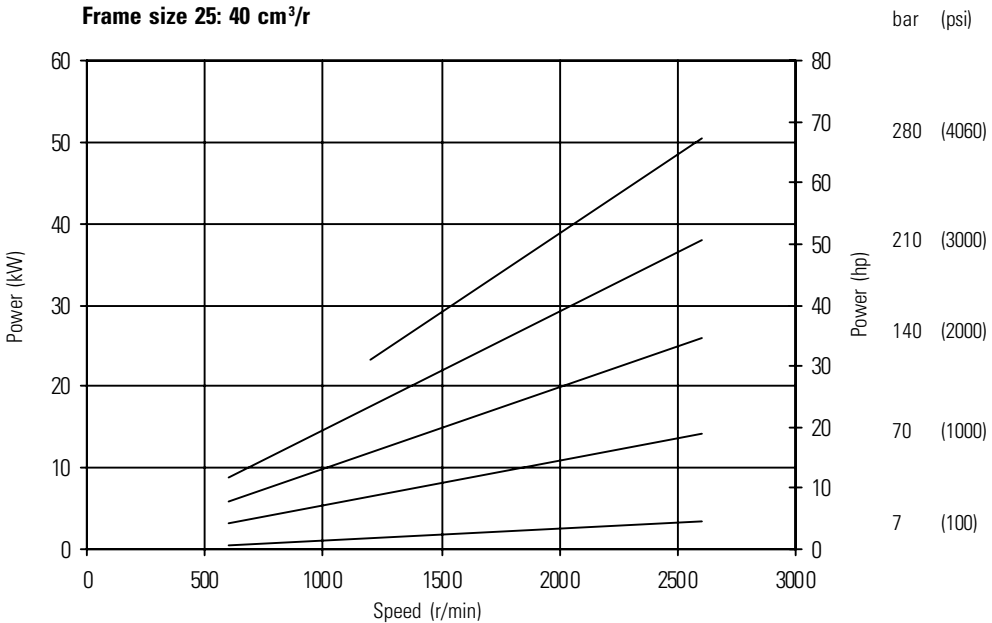
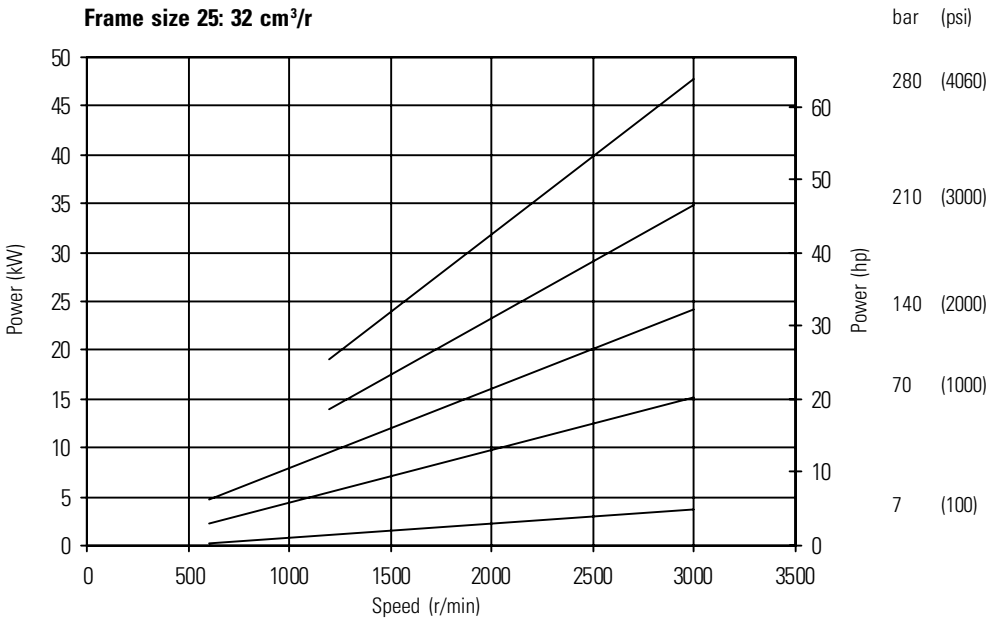

Typical Input Power - Mobile (cont.)

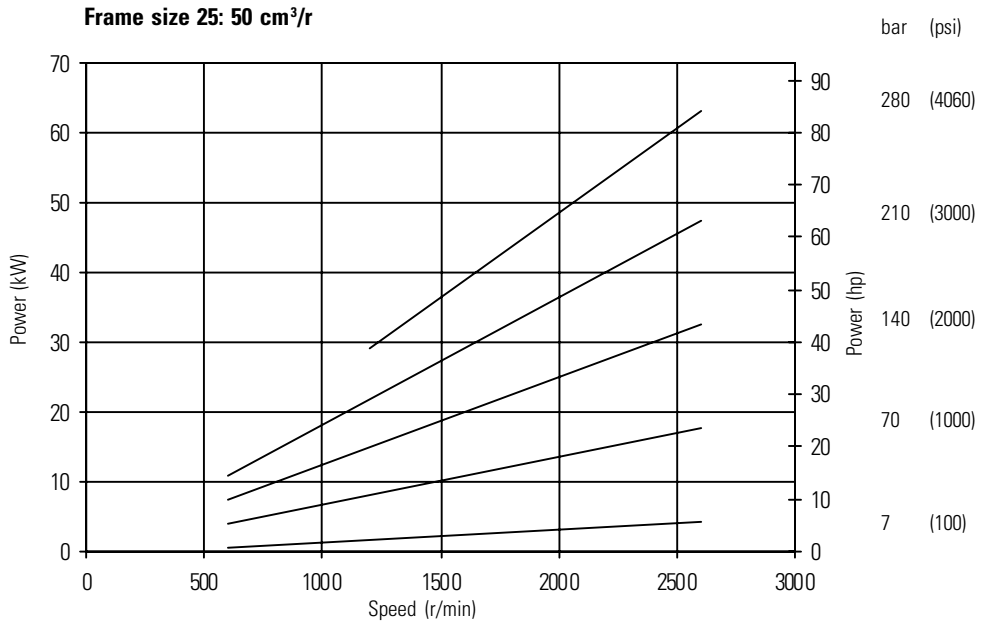
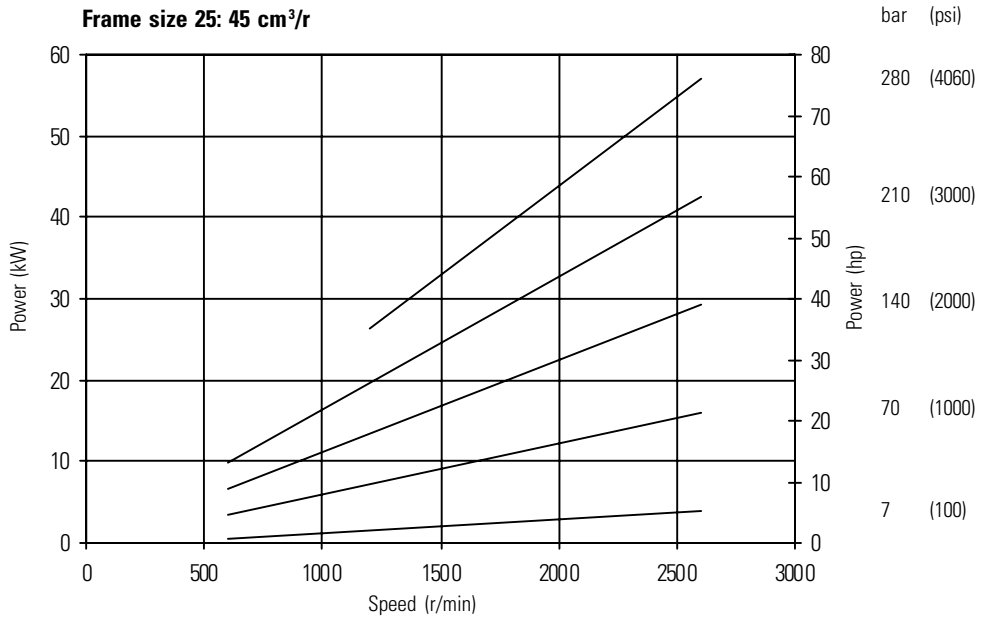

Typical Input Power - Mobile (cont.)

Frame size 25: 63 cm³/r

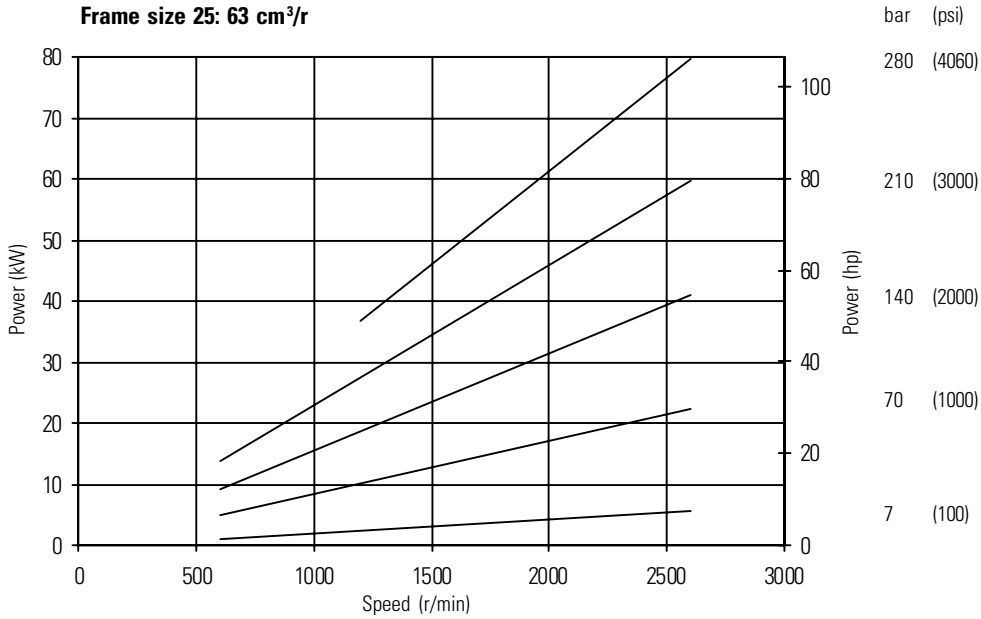

Frame size 25: 71 cm³/r

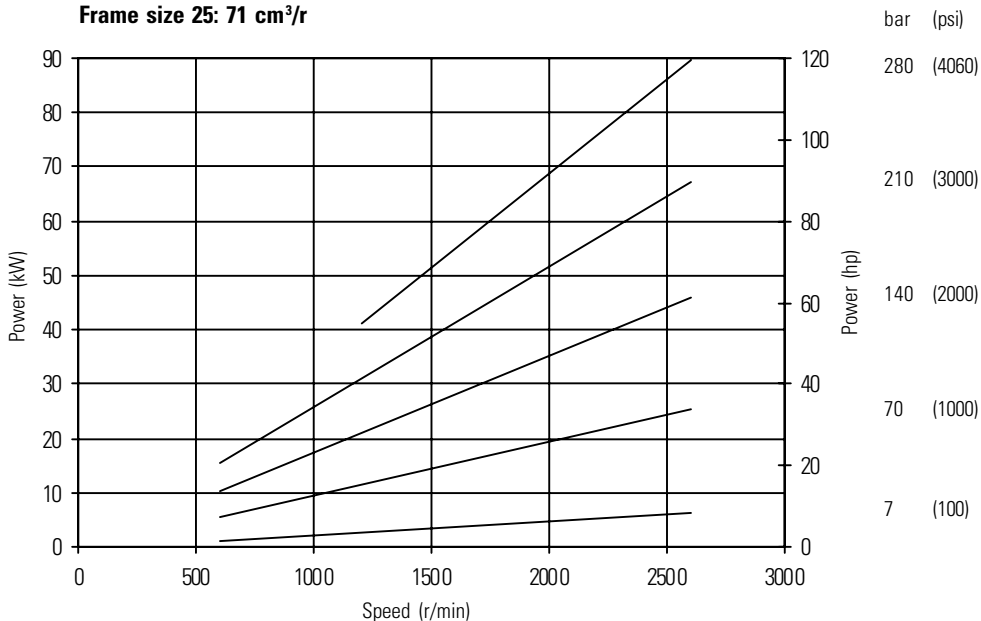

Typical Input Power - Mobile (cont.)

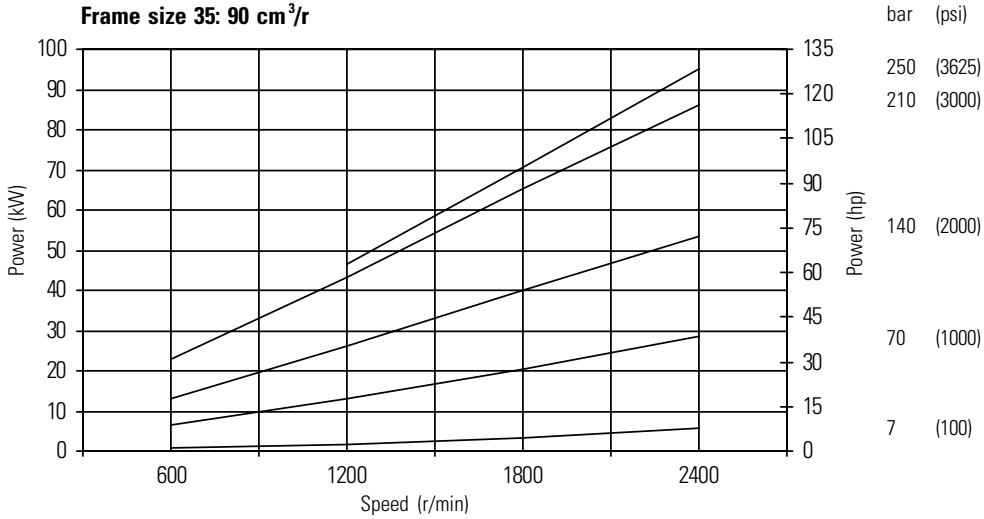
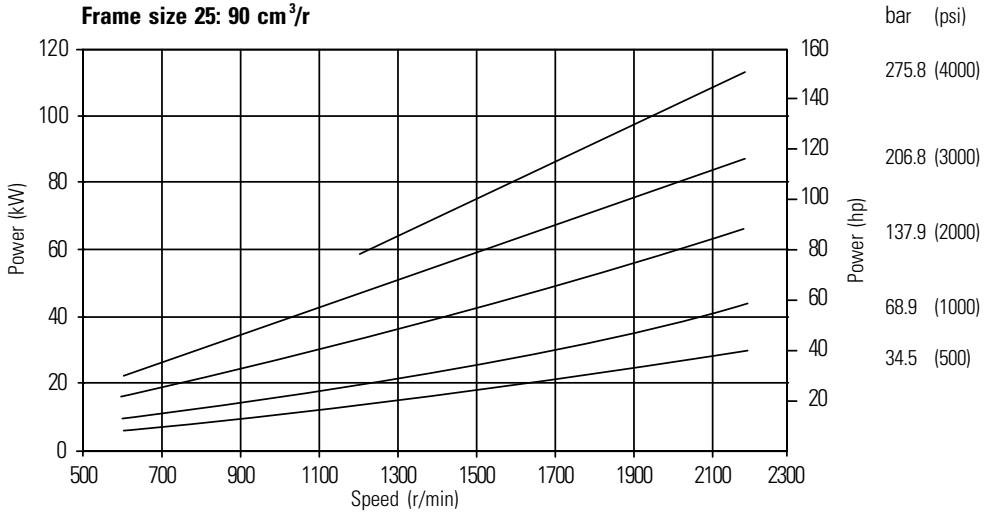
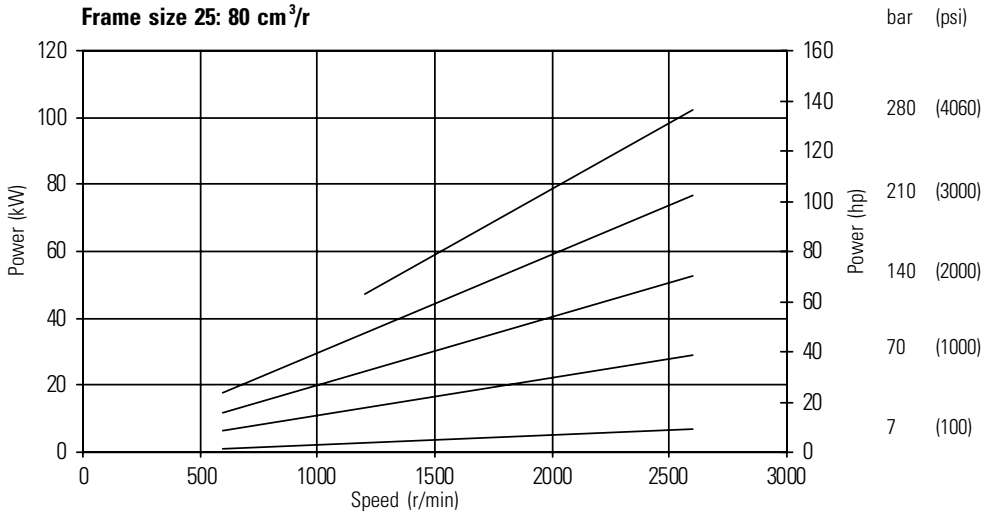

Typical Input Power - Mobile (cont.)

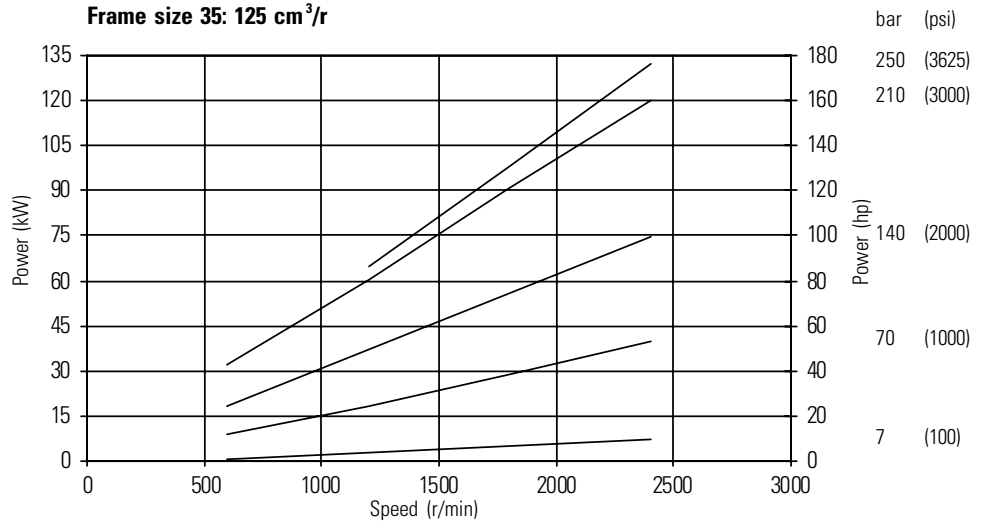
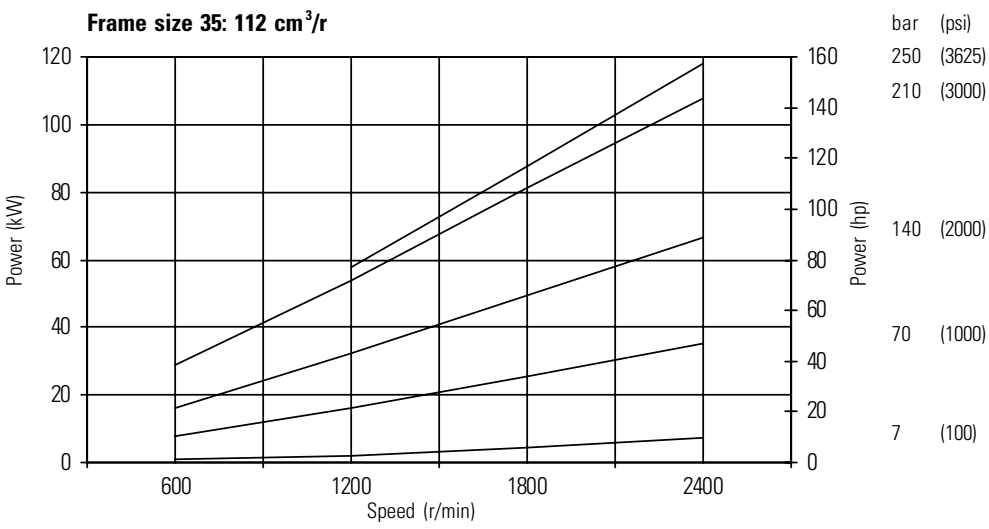
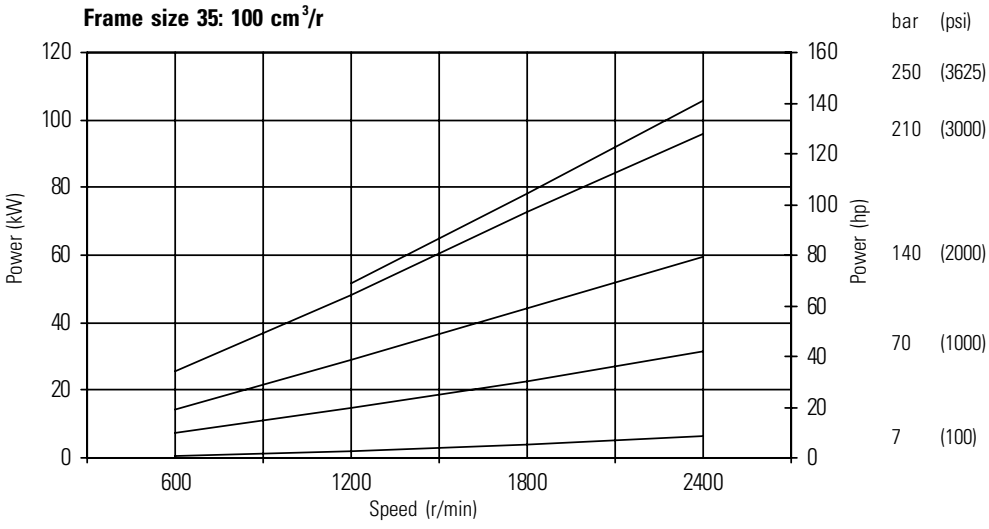

Typical Input Power - Mobile (cont.)

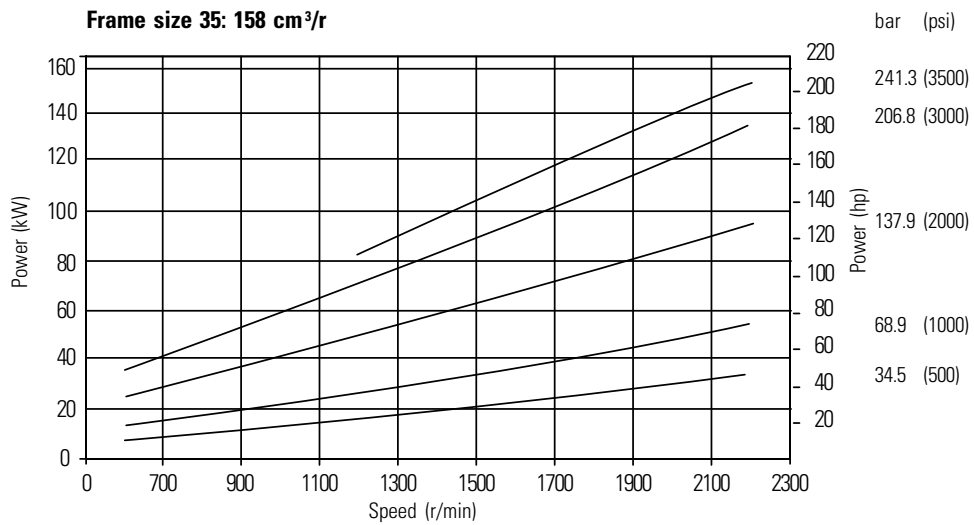
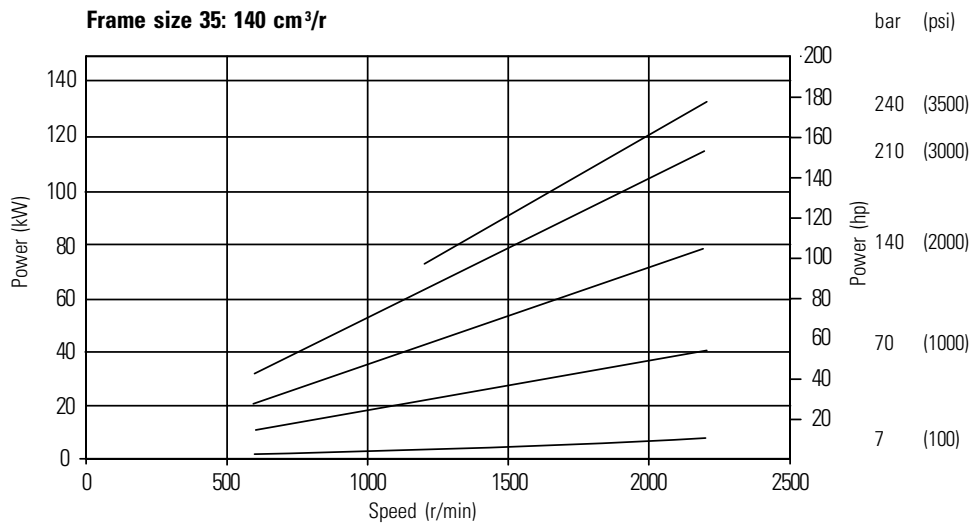
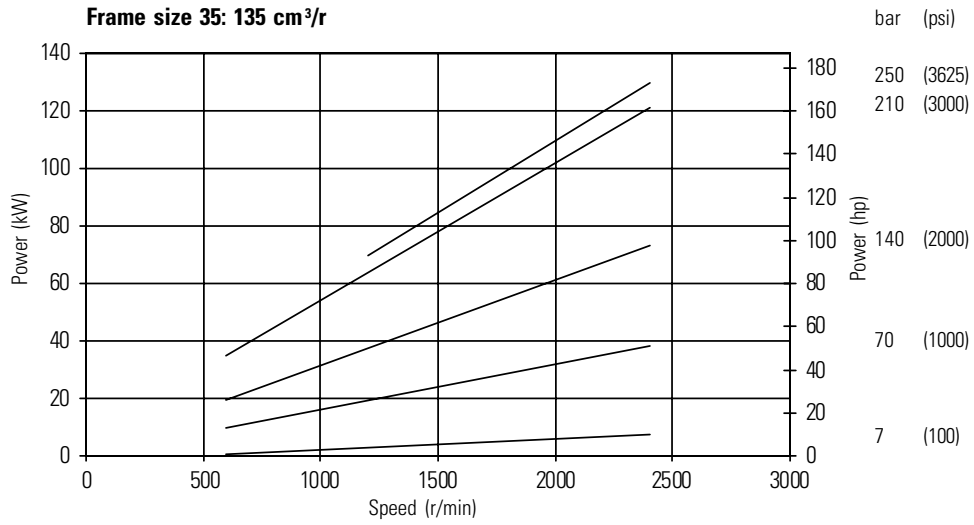

Typical Input Power - Mobile (cont.)

Frame size 45: 140 cm³/r

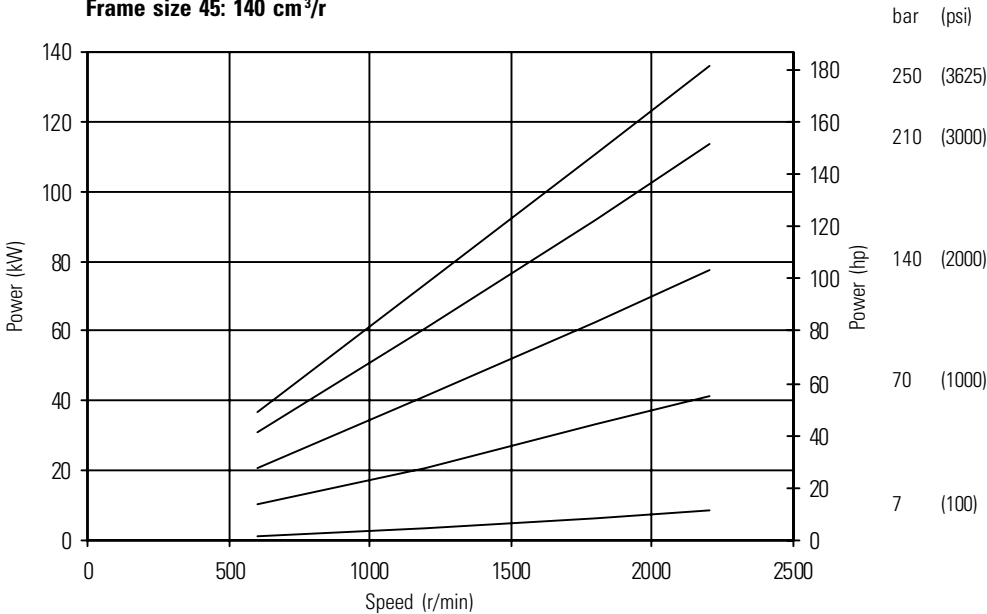

Frame size 45: 160 cm³/r

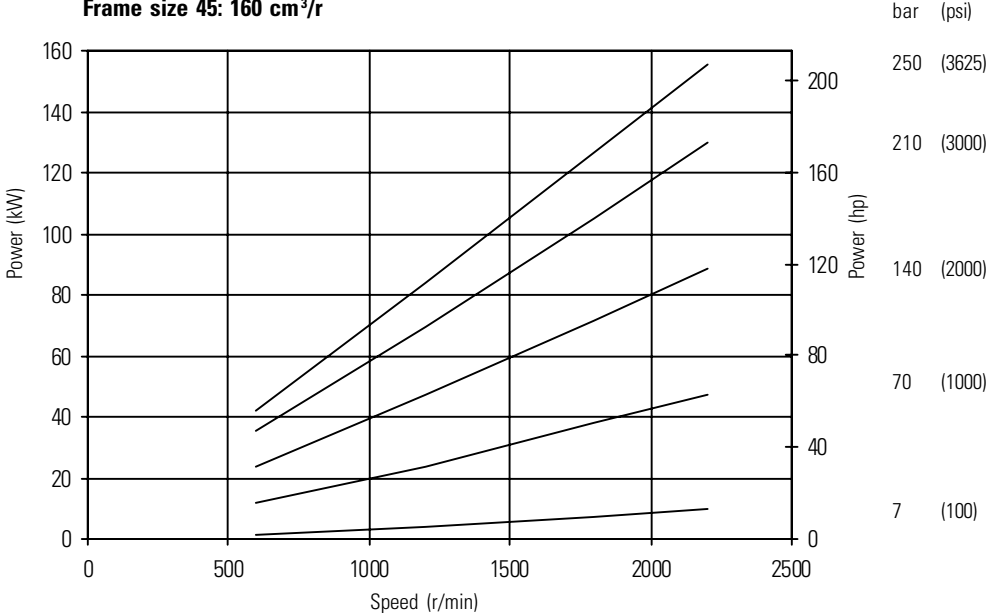

Typical Input Power - Mobile (cont.)

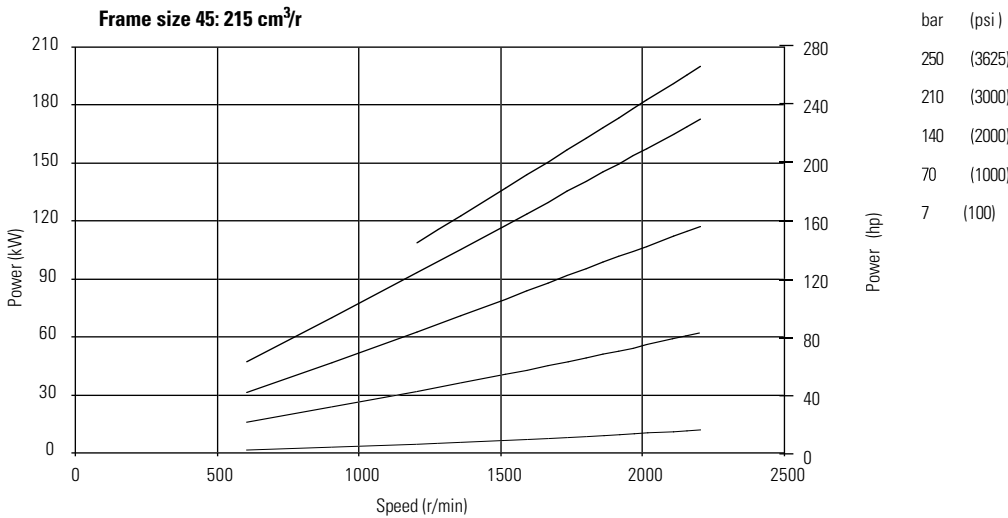
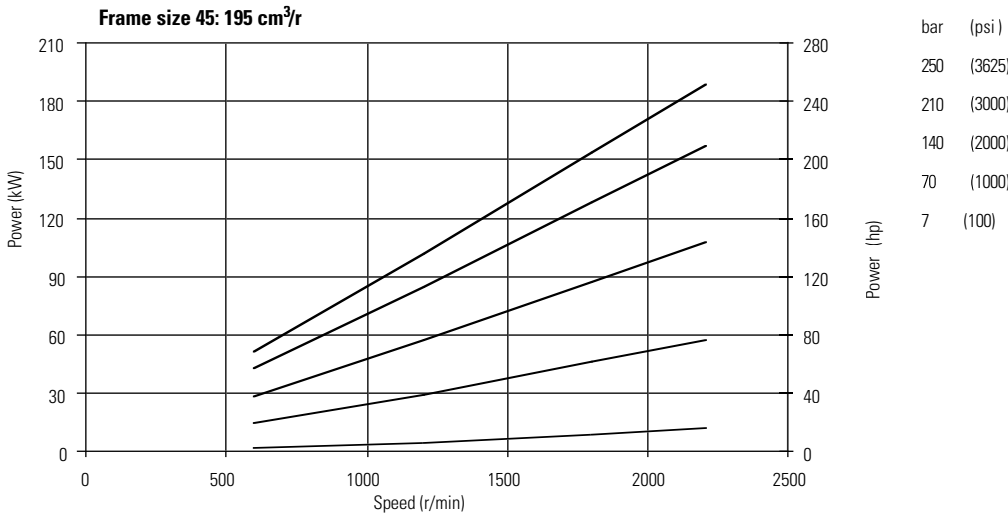
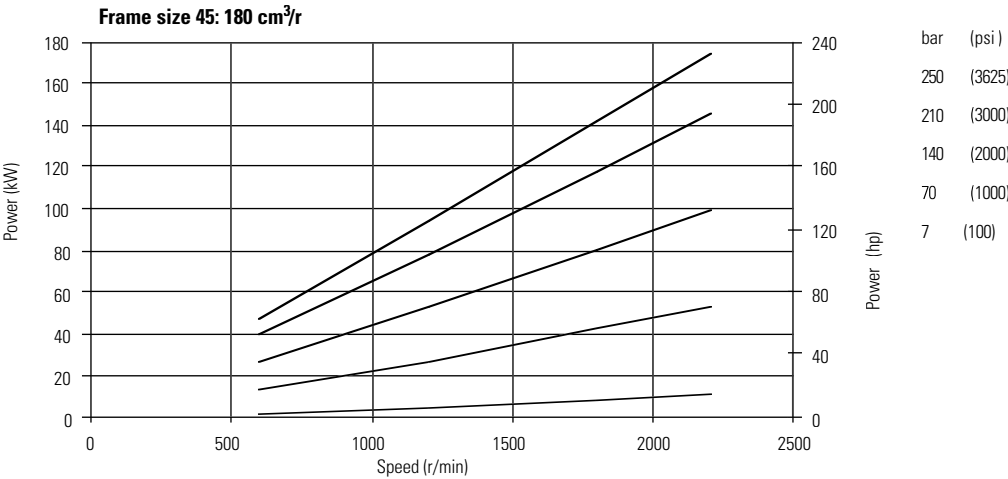

VMQ1 25

Single Pumps

Installation Dimensions
in mm (in)

For shaft dimensions see
pages 63-66

In-line port arrangement
illustrated.

For alternative port arrange-
ments see Model Code 19

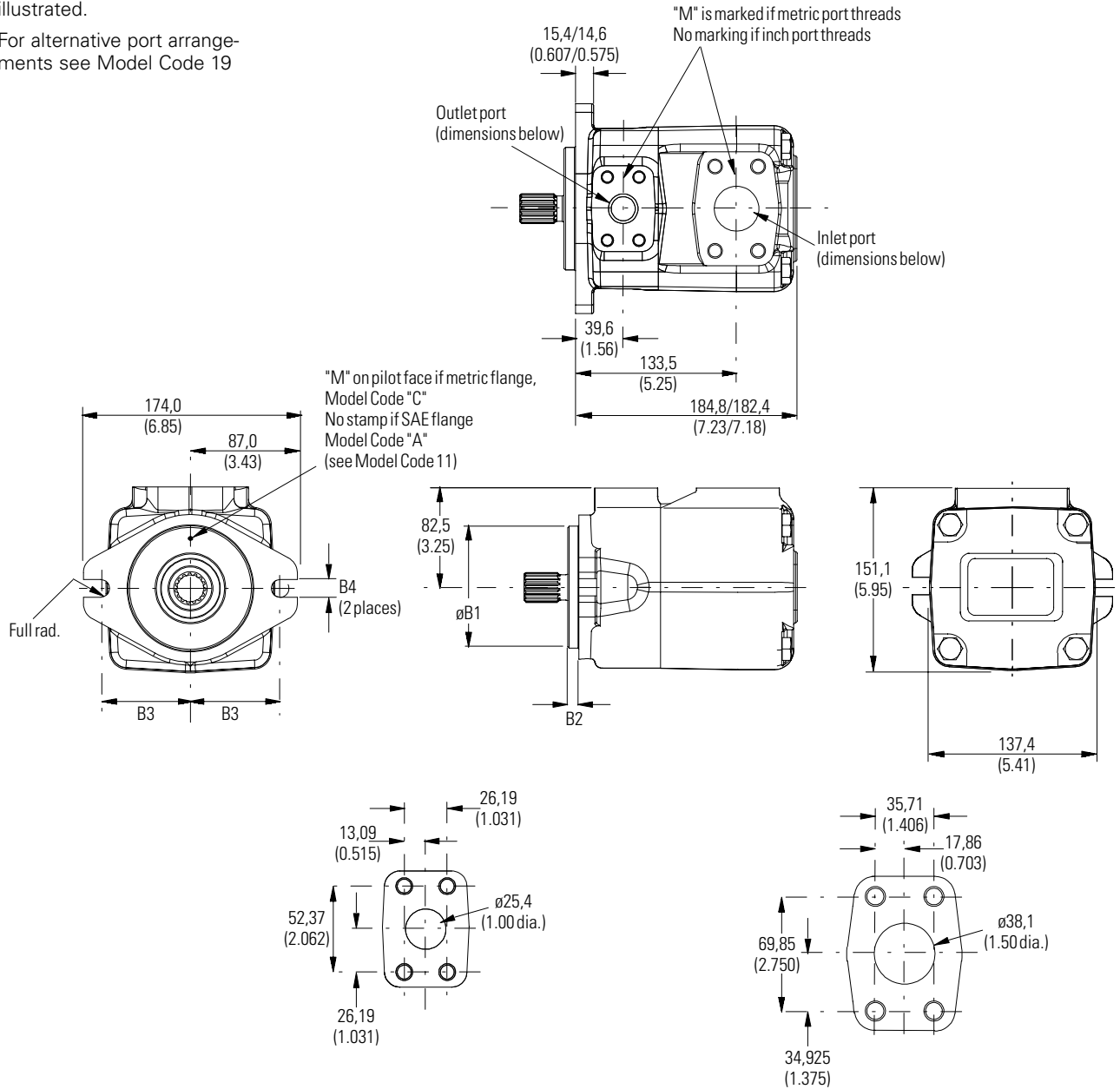
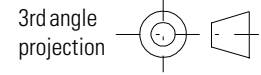

Outlet port

Code A: SAE J518 4-bolt flange
Code B: ISO 6162 4-bolt flange
Threads:
Code A: $\frac{3}{8}$ "-16UNC-2B, 22,0(0.87) min. depth
Code B: M10x1.5, 17,0(0.67) min. depth

Inlet port

Code A: SAE J518 4-bolt flange
Code B: ISO 6162 4-bolt flange
Threads:
Code A: $\frac{1}{2}$ "-13UNC-2B, 27,0(1.06) min. depth
Code B: M12x1.75, 19,5(0.77) min. depth

MODEL CODE 11	FLANGETYPE	$\phi B1$	B2	B3	B4
A	SAE 101-2	101,55/101,6 (3.998/4.000)	9,19/9,70 (0.362/0.382)	73,00 (2.874)	14,17/14,55 (0.558/0.573)
C	ISO 3019/2 100A2HW	99,946/100,0 (3.935/3.937)	9,00/9,50 (0.354/0.374)	70,00 (2.756)	14,00/14,27 (0.551/0.562)

VMQ1 35

Single Pumps

Installation Dimensions
in mm (in)

For shaft dimensions see
pages 63-66

In-line port arrangement
illustrated.

For alternative port arrange-
ments see Model Code 19

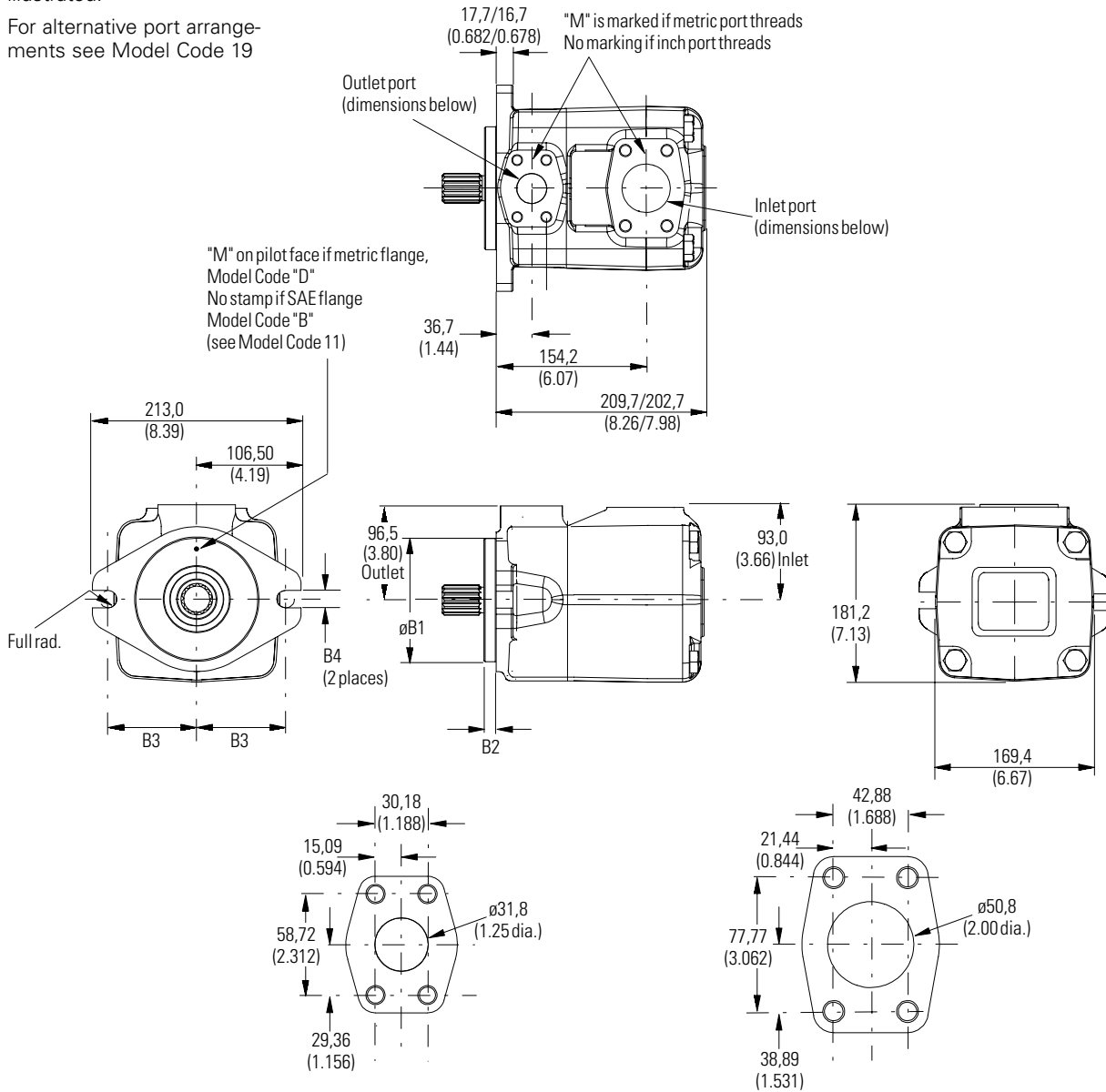
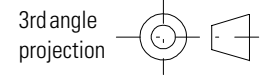

Outlet port

Code A: SAE J518 4-bolt flange
Code B: ISO 6162 4-bolt flange
Threads:
Code A: $\frac{7}{16}$ "-14UNC-2B, 28,4(1.12)min. depth
Code B: M10x 1.5, 17,0(0.67)min. depth

Inlet port

Code A: SAE J518 4-bolt flange
Code B: ISO 6162 4-bolt flange
Threads:
Code A: $\frac{1}{2}$ "-13UNC-2B, 27,0(1.06)min. depth
Code B: M12x 1.75, 20,0(0.79)min. depth

MODEL CODE 11	FLANGETYPE	ØB1	B2	B3	B4
B	SAE 127-2	126,95/127,00 (4.998/5.000)	12,19/12,70 (0.480/0.500)	90,50 (3.563)	17,37/17,75 (0.684/0.699)
D	ISO 3019/2 125A2HW	124,94/125,00 (4.919/4.921)	9,00/9,50 (0.354/0.374)	90,00 (3.543)	18,00/18,27 (0.709/0.719)

VMQ1 45

Single Pumps

Installation Dimensions
in mm (in)

For shaft dimensions see
pages 63-66

In-line port arrangement
illustrated.

For alternative port arrange-
ments see Model Code 19

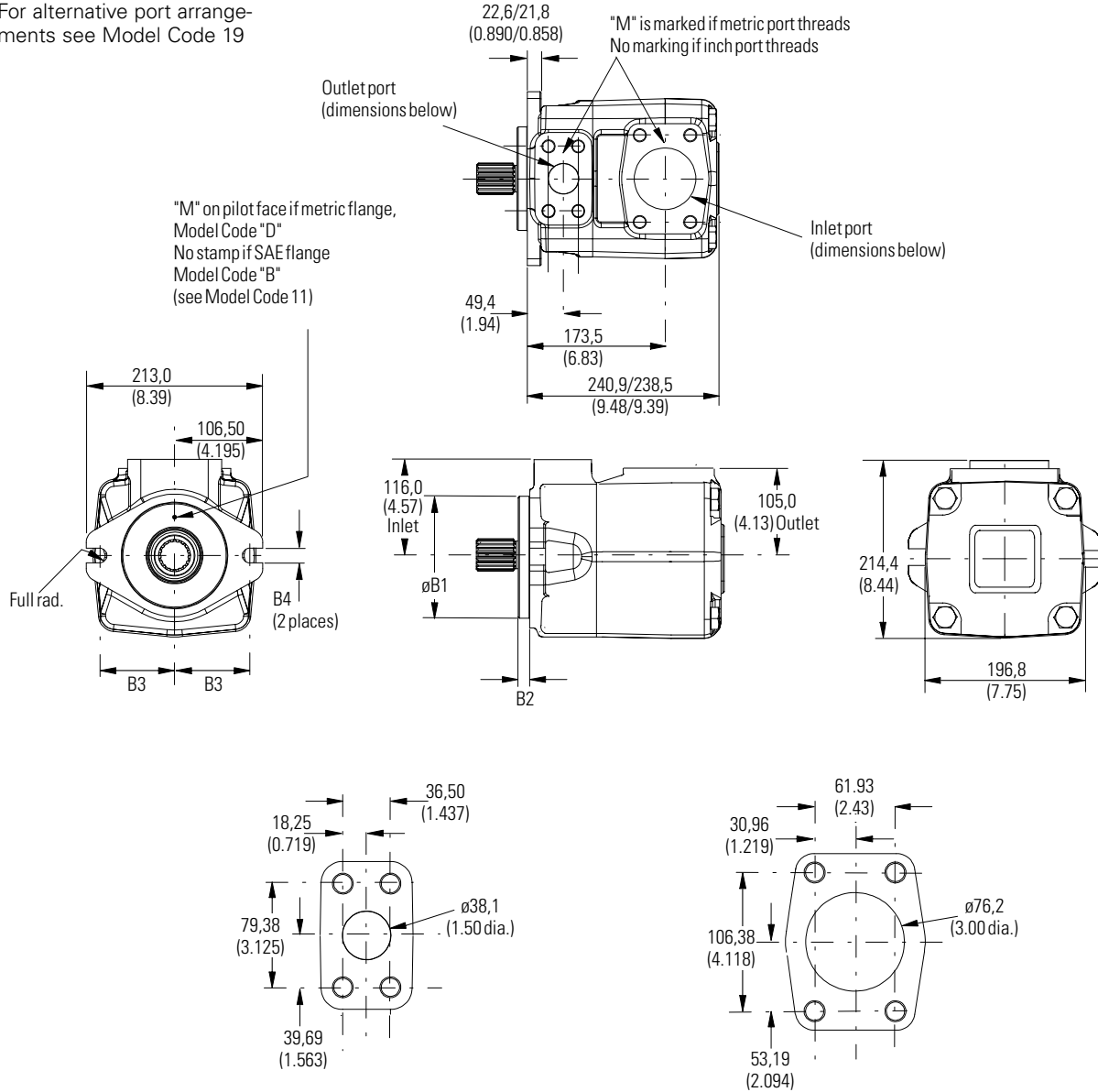
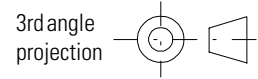

Outlet port

Code A: SAE J518 4-bolt flange
Code B: ISO 6162 4-bolt flange
Threads:
Code A: 5/8"-11UNC-2B, 35,0(1.38) min. depth
Code B: M16 x 2,0, 25,5 (1.00) min. depth

Inlet port

Code A: SAE J518 4-bolt flange
Code B: ISO 6162 4-bolt flange
Threads:
Code A: 5/8"-11UNC-2B, 30,2(1.19) min. depth
Code B: M16 x 2,0, 28,5 (1.12) min. depth

MODEL CODE 11	FLANGETYPE	ØB1	B2	B3	B4
B	SAE 127-2	126,95/127,00 (4.998/5.000)	12,19/12,70 (0.480/0.500)	90,50 (3.563)	17,37/17,75 (0.684/0.699)
D	ISO 3019/2 125A2HW	124,94/125,00 (4.919/4.921)	9,00/9,50 (0.354/0.374)	90,00 (3.543)	18,00/18,27 (0.709/0.719)

VMQ1 25T

Thru Drive Pumps

Installation Dimensions
in mm (in)

Illustration shows assembly with port configuration C (outlet in line with inlet) as per Model Code 19

For shaft options see pages 63-66

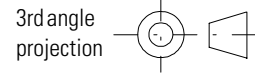

"M" on pilot face if metric flange, Model Code "C"
No stamp if SAE flange Model Code "A" (see Model Code 11)

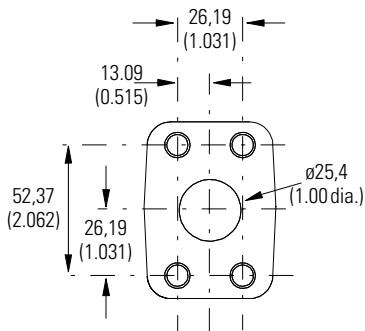
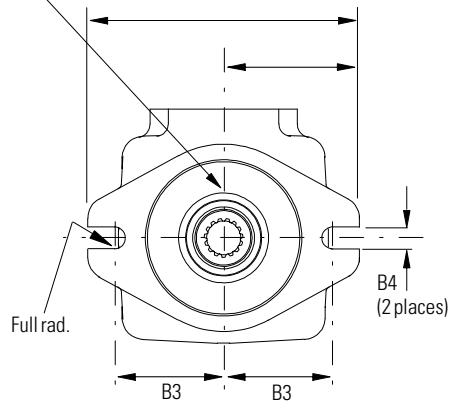

Outlet port

Code A: SAE J518 4-bolt flange
Code B: ISO 6162 4-bolt flange
Threads:
Code A: 3/8" -16UNC-2B, 22,0 (0.87) min. depth
Code B: M10 x 1,5, 17,0 (0.67) min. depth

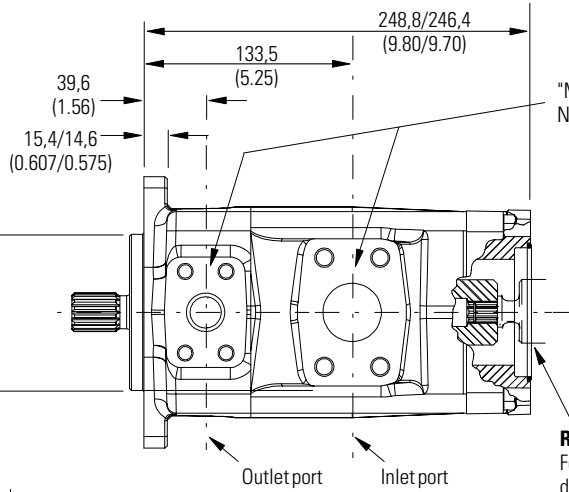

"M" is marked if metric port threads
No marking if inch port threads

Rear Mount Pumps

For list of suitable fixed and variable displacement Vickers™ pumps, see page 56.
For details of rear mount and coupling options, see next page.

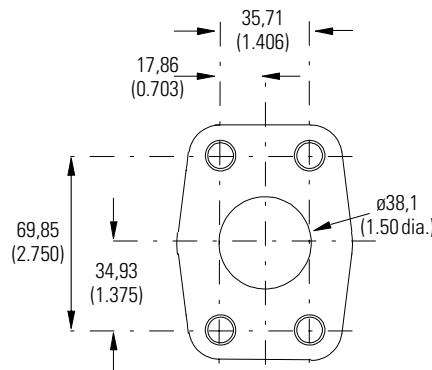
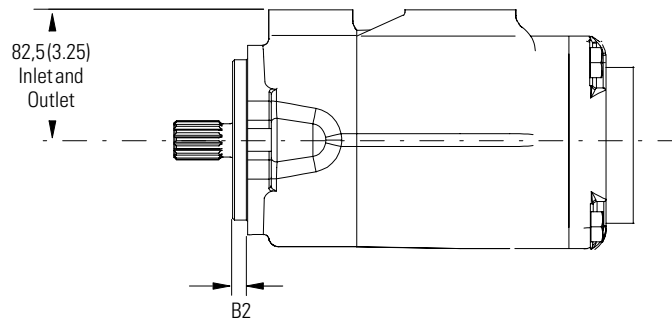

Inlet port

Code A: SAE J518 4-bolt flange
Code B: ISO 6162 4-bolt flange
Threads:
Code A: 1/2" -13UNC-2B, 27,0 (1.06) min. depth
Code B: M12 x 1,75, 19,5 (0.77) min. depth

MODEL CODE 11	FLANGETYPE	ØB1	B2	B3	B4
A	SAE 101-2	101,55/101,60 (3.998/4.000)	9,19/9,70 0.362/0.382)	73,00 (2.874)	14,17/14,55 (0.558/0.573)
C	ISO 3019/2 100A2HW	99,946/100,00 (3.935/3.937)	9,00/9,50 (0.354/0.374)	70,00 (2.756)	14,00/14,27 (0.551/0.562)

VMQ1 25T

Thru Drive Pumps Rear Mount/Coupling Details

Installation Dimensions
in mm (in)

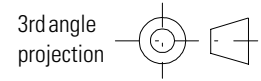

Detail of SAE A flange
per Model Code 12 = A
(SAE flange in line with
mounting flange.)

Coupling options per
Model Code 15 16 and
details are given in
table below.

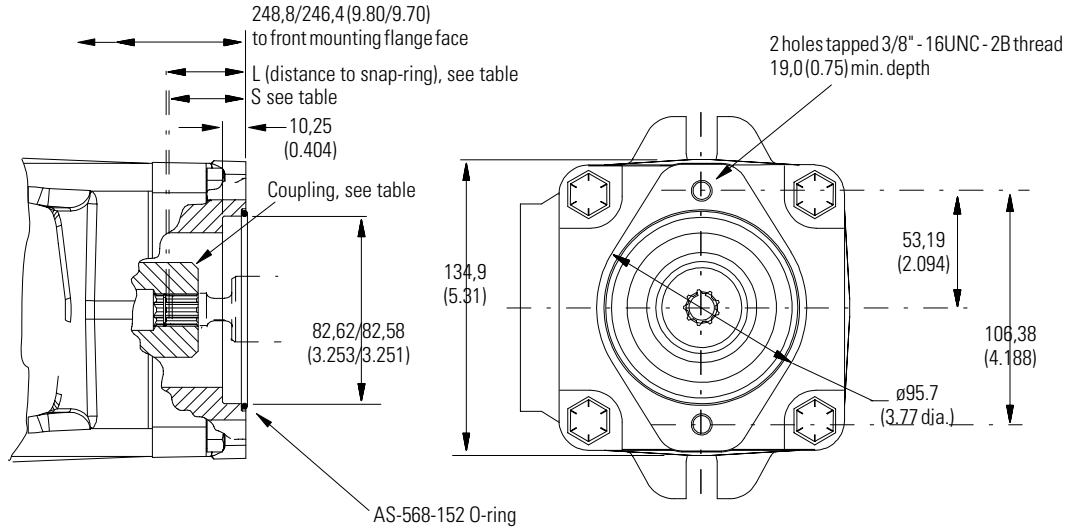

Detail of SAE B flange
per Model Code 12 = E
(SAE B flange in line with
mounting flange.)

Coupling options per
Model Code 15 16 and
details are given in
table below.

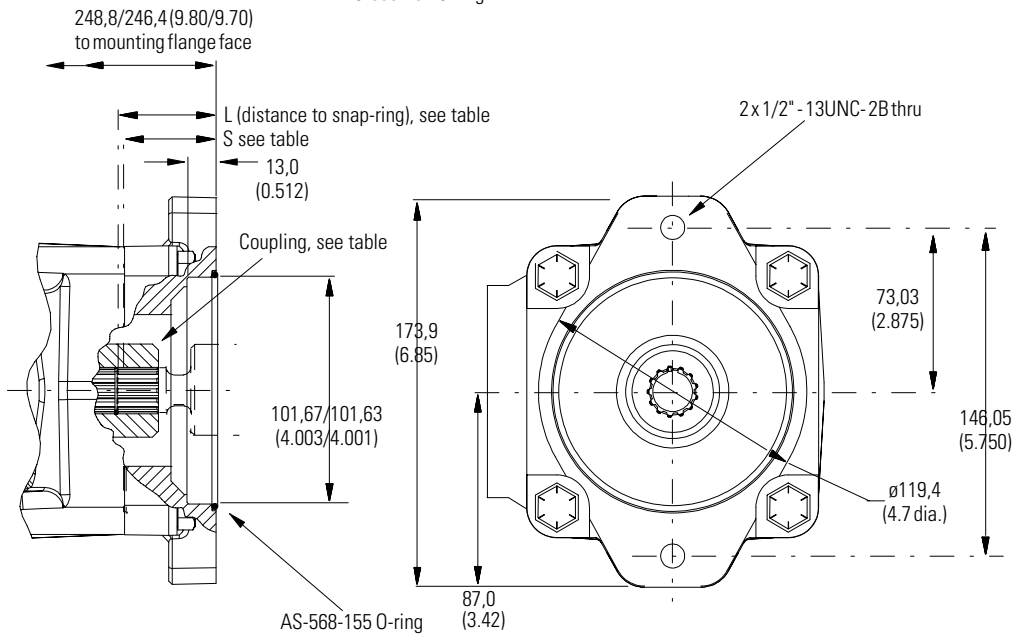

COUPLING CODE	DESCRIPTION	SHAFT EXTENSION S	L
16	For pump shaft of SAE "A" size with 30° involute splined shaft (per SAE std J744 JUL88) 9T 16/32 DP (per ANSI B92.1a 1976)	32,8/31,2 (1.263/1.257)	33,5 (1.32) min.
22	For pump shaft of SAE "B" size with 30° involute splined shaft (per SAE std J744 JUL88) 13T 16/32 DP (per ANSI B92.1a 1976)	41,8/40,2 (1.64/1.58)	42,5 (1.67) min.
25	For pump shaft of SAE "B-B" size with 30° involute splined shaft (per SAE std J744 JUL88) 15T 16/32 DP (per ANSI B92.1a 1976)	46,8/45,2 (1.84/1.78)	47,4 (1.87) min.

VMQ1 35T

Thru Drive Pumps

Installation Dimensions
in mm (in)

Illustration shows assembly
with port configuration C

(outlet in line with inlet)
as per Model Code 19

For shaft options see
pages 63-66

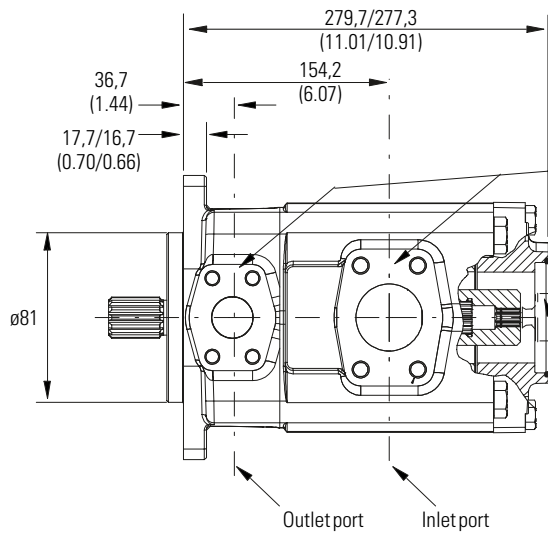

"M" is marked if metric port threads
No marking if inch port threads

Rear Mount Pumps

For list of suitable fixed and variable displacement Vickers™ pumps, see page 56. For details of rear mount and coupling options, see pages 54 and 55.

"M" on pilot face if metric flange,
Model Code "D"
No stamp if SAE flange
Model Code "B"
(see Model Code 11)

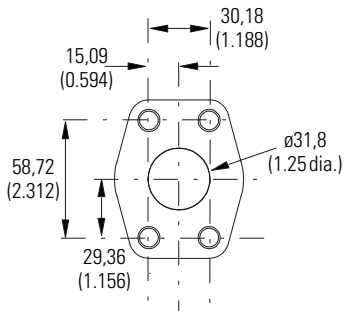
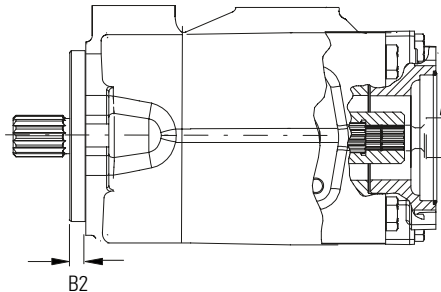
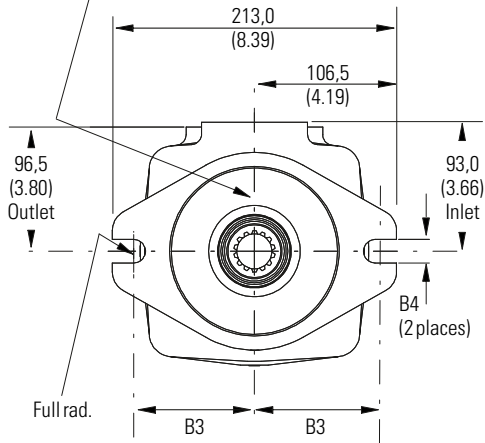

Outlet port

Code A: SAE J518 4-bolt flange
Code B: ISO 6162 4-bolt flange
Threads:
Code A: 7/16"-14UNC-2B, 28,4(1.12) min. depth
Code B: M10x1,5, 17,0(0.67) min. depth

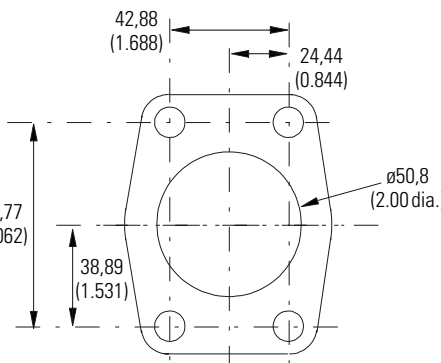

Inlet port

Code A: SAE J518 4-bolt flange
Code B: ISO 6162 4-bolt flange
Threads:
Code A: 1/2"-13UNC-2B, 27,0(1.06) min. depth
Code B: M12x1,75, 20,0(0.79) min. depth

MODEL CODE 11	FLANGETYPE	ØB1	B2	B3	B4
B	SAE 127-2	126,95/127,00 (4.998/5.000)	12,19/12,70 (0.480/0.500)	90,50 (3.563)	17,37/17,75 (0.684/0.699)
D	ISO 3019/2 125A2HW	124,94/125,00 (4.919/4.921)	9,00/9,50 (0.354/0.374)	90,00 (3.543)	18,00/18,27 (0.709/0.719)

VMQ1 45T

Thru Drive Pumps

Installation Dimensions
in mm (in)

Illustration shows assembly
with port configuration C

(outlet in line with inlet) as
per Model Code 19

For shaft options see
pages 63-66

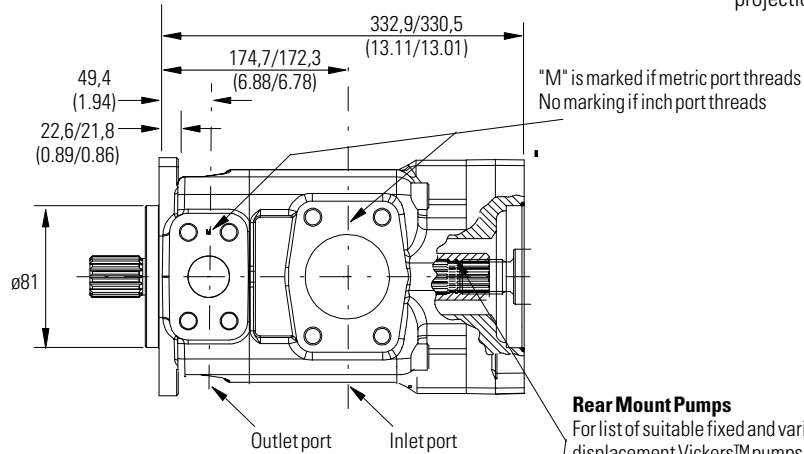

Rear Mount Pumps
For list of suitable fixed and variable displacement Vickers™ pumps, see page 56. For details of rear mount and coupling options, see pages 54 and 55.

"M" on pilot face if metric flange,
Model Code "D"
No stamp if SAE flange
Model Code "B"
(see Model Code 11)

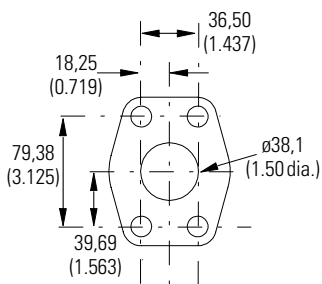
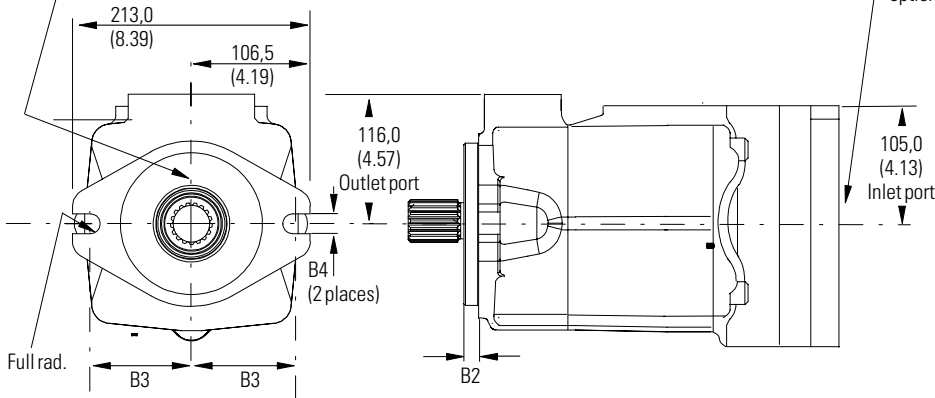

Outlet port

Code A: SAE J518 4-bolt flange
Code B: ISO 6162 4-bolt flange
Threads:
Code A: 5/8"-11UNC-2B, 35,0(1.38) min. depth
Code B: M16 x 2,00, 25,5 (1.00) min. depth

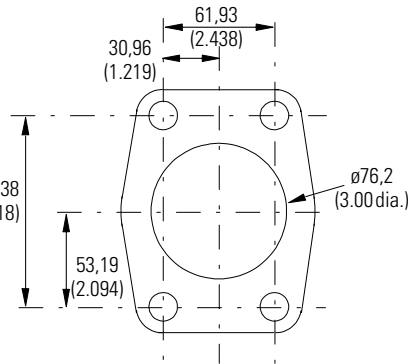

Inlet port

Code A: SAE J518 4-bolt flange
Code B: ISO 6162 4-bolt flange
Threads:
Code A: 5/8"-11UNC-2B, 30,2(1.19) min. depth
Code B: M16 x 2,00, 28,5 (1.12) min. depth

MODEL CODE 11	FLANGETYPE	ØB1	B2	B3	B4
B	SAE 127-2	126,95/127,00 (4.998/5.000)	12,19/12,70 (0.480/0.500)	90,50 (3.563)	17,37/17,75 (0.684/0.699)
D	ISO 3019/2 125A2HW	124,94/125,00 (4.919/4.921)	9,00/9,50 (0.354/0.374)	90,00 (3.543)	18,00/18,27 (0.709/0.719)

VMQ1 35T/45T

Thru Drive Pumps Rear Mount/Coupling Details

Installation Dimensions
in mm (in)

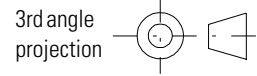

Detail of SAE A flange
per Model Code 12 = D

(SAE A flange at 45° CW
to mounting flange.)

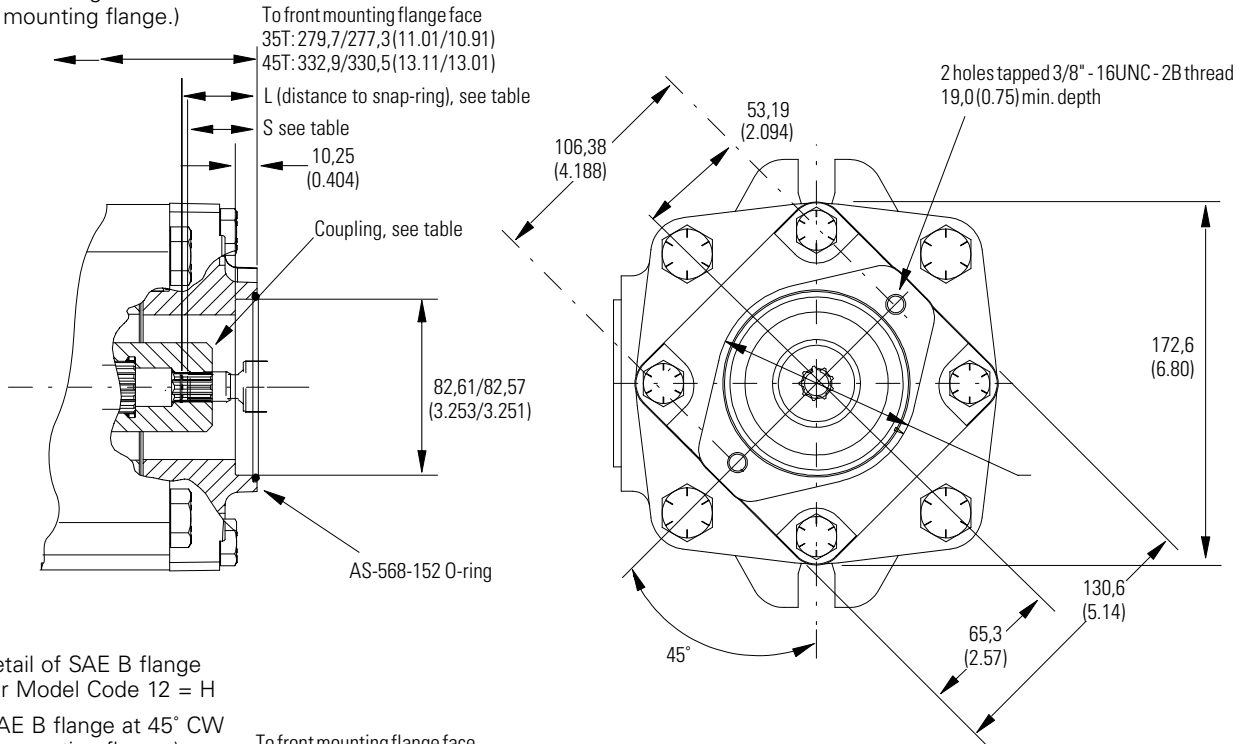

Detail of SAE B flange
per Model Code 12 = H

(SAE B flange at 45° CW
to mounting flange.)

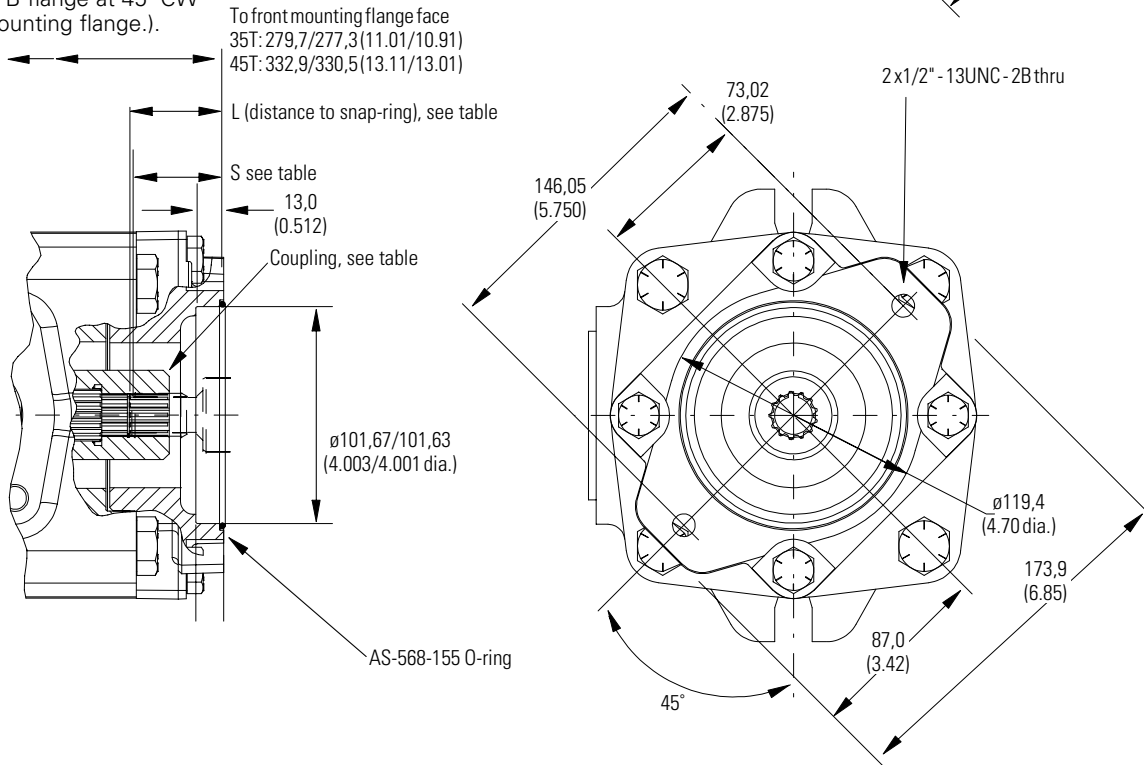

VMQ1 35T/45T

Thru Drive Pumps Rear Mount/Coupling Details

Installation Dimensions
in mm (in)

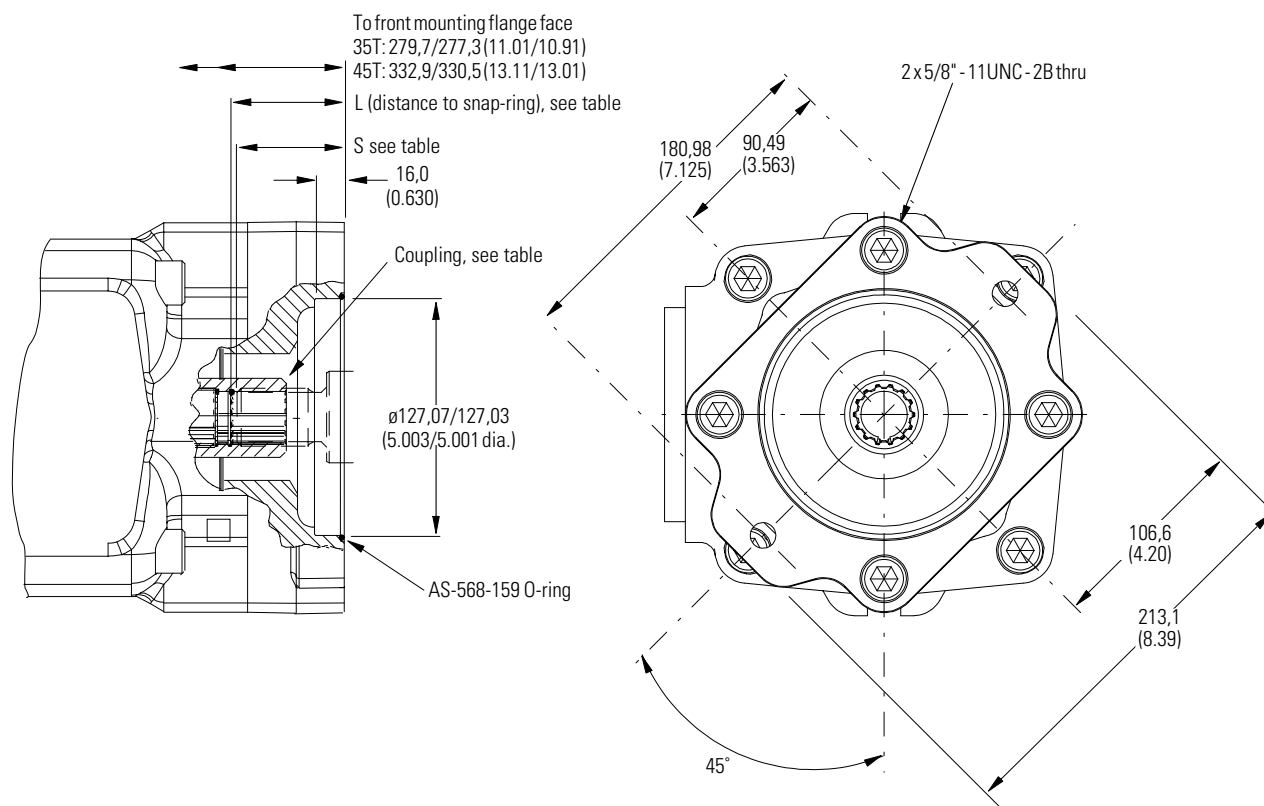
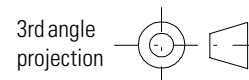

COUPLING CODE	DESCRIPTION	SHAFT EXTENSION S	L	
			35T	45T
16	For pump shaft of SAE "A" size with 30° involute splined shaft (per SAE std J744 JUL88) 9T 16/32 DP (per ANSI B92.1a 1976)	32,8/31,2 (1.29/1.23)	33,3 (1.31) min.	34,2 (1.35) min.
22	For pump shaft of SAE "B" size with 30° involute splined shaft (per SAE std J744 JUL88) 13T 16/32 DP (per ANSI B92.1a 1976)	41,8/40,2 (1.64/1.58)	42,3 (1.67) min.	43,2 (1.70) min.
25	For pump shaft of SAE "B-B" size with 30° involute splined shaft (per SAE std J744 JUL88) 15T 16/32 DP (per ANSI B92.1a 1976)	46,8/45,2 (1.84/1.78)	47,4 (1.87) min.	48,3 (1.90) min.
32	For pump shaft of SAE "C" size with 30° involute splined shaft (per SAE std J744 JUL88) 14T 12/24 DP (per ANSI B92.1a 1976)	56,8/55,2 (2.23/2.17)	58,5 (2.30) min.	58,8 (2.31) min.

Selection of Vickers™ Pumps for Mounting on Thru-Drive Models

VMQ1 THRU-DRIVE MODEL	MATING PUMP	MATING PUMP SHAFT CODE
25VMQT	V10	11
	V20	62
	PVB5/6 piston pump	S124
	PVM018/020	03
	V2010/2020 double pump	11
	20V(Q)	151
	25V(Q)	11
	2520V(Q) double pump	11
	PVB10/15 piston pump	S124
	PVM018, 020, 045, 050, 057	07
	VMQ125	09
	35VMQT	V10
V20		62
PVB5/6 piston pump		S124
PVM018/020		03
V2010/2020 double pump		11
20V(Q)		151
25V(Q)		11
2520V(Q) double pump		11
PVB10/15 piston pump		S124
VMQ125		09
35V(Q)		11
35**V(Q) double pump		11
45V(Q)		11
45**V(Q) double pump		11
PVM057, 063, 131, 141		11
VMQ135	02	
45VMQT	V10	11
	V20	62
	PVB5/6 piston pump	S124
	PVM018/020	03
	V2010/2020 double pump	11
	20V(Q)	151
	25V(Q)	11
	2520V(Q) double pump	11
	PVB10/15 piston pump	S124
	VMQ125	09
	VMQ22525 double pump	02
	35V(Q)	11
	35**V(Q) double pump	11
	45V(Q)	11
	45**V(Q) double pump	11
	PVM057, 063, 131, 141	11
	VMQ135	02
	VMQ145	09
VMQ23525 double pump	02	
VMQ245** double pump	09	

VMQ2 2525

Double Pumps

Installation Dimensions
in mm (in)

For shaft dimensions
see pages 63-66

The inlet/outlet configuration
of the illustration is:

Model code 25 = C

Model code 26 = B

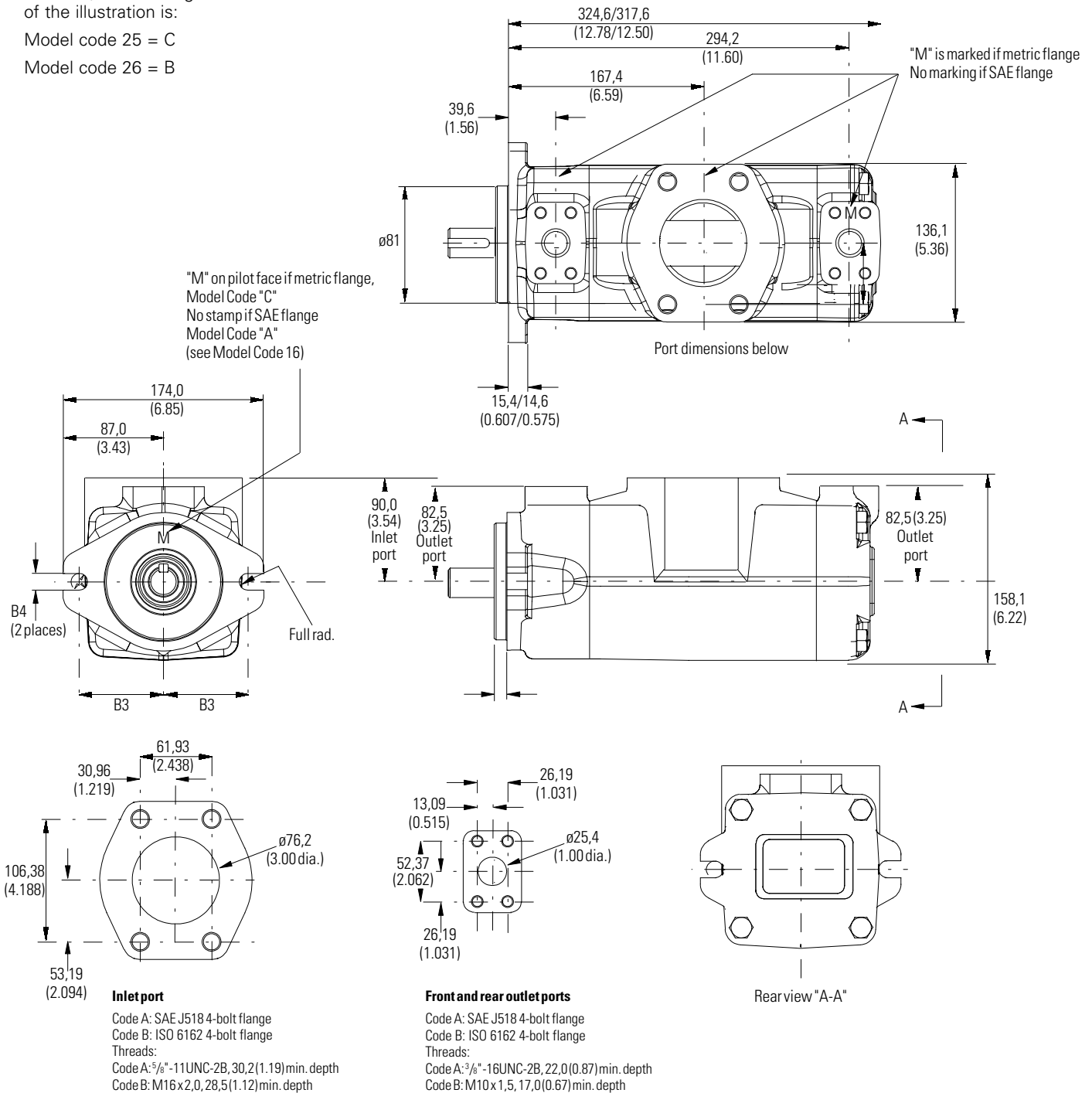
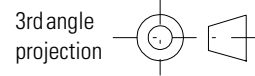

MODEL CODE 16	FLANGETYPE	ØB1	B2	B3	B4
A	SAE 101-2	101,55/101,60 (3.998/4.000)	9,19/9,70 0.362/0.382)	73,00 (2.874)	14,17/14,55 (0.558/0.573)
C	ISO 3019/2 100A2HW	99,946/100,00 (3.935/3.937)	9,00/9,50 (0.354/0.374)	70,00 (2.756)	14,00/14,27 (0.551/0.562)

VMQ2 3525

Double Pumps

Installation Dimensions
in mm (in)

For shaft dimensions
see pages 63-66

The inlet/outlet configuration
of the illustration is:

Model code 25 = C

Model code 26 = B

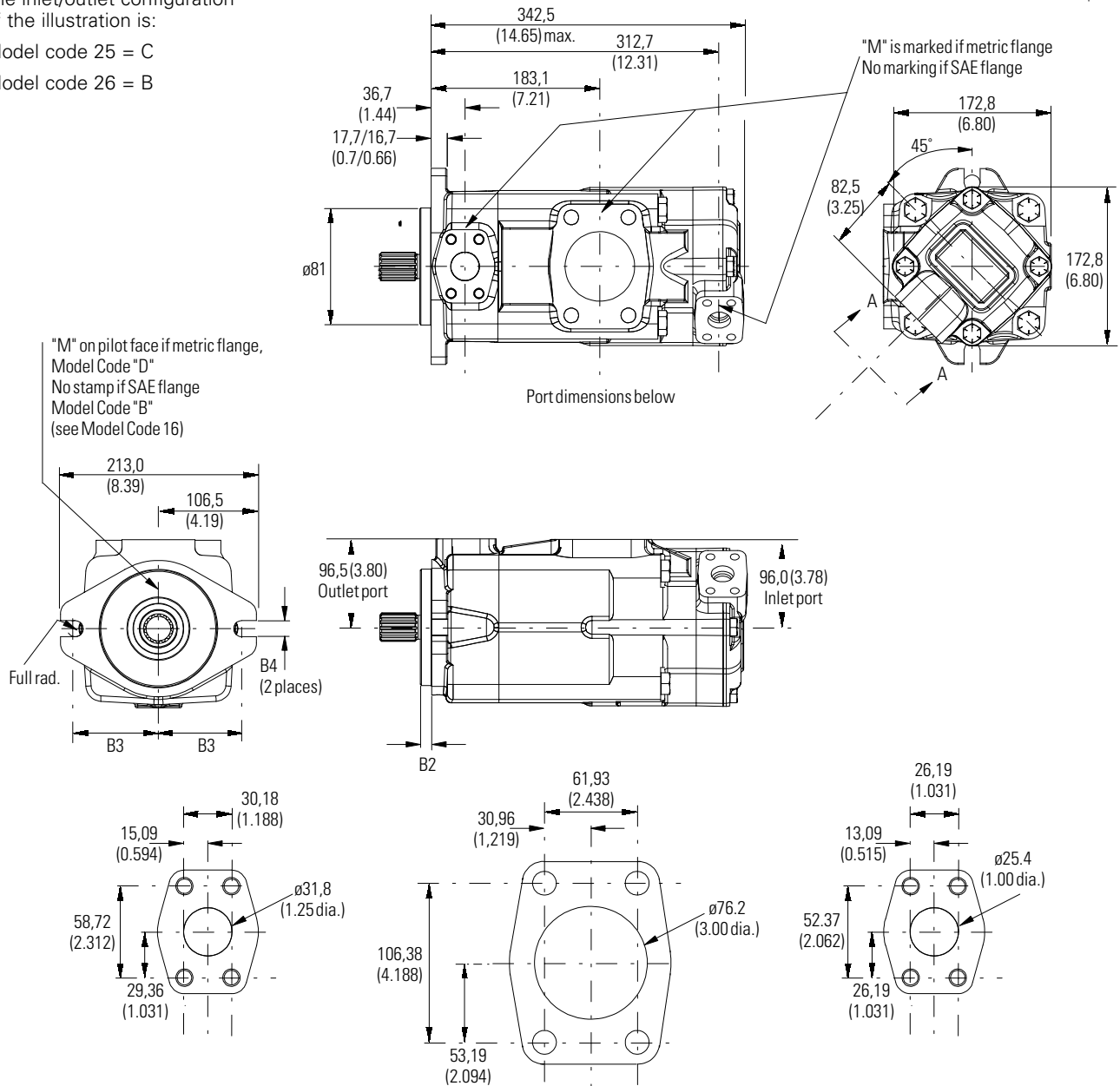
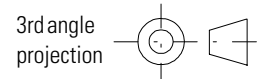

"M" on pilot face if metric flange,
Model Code "D"
No stamp if SAE flange
Model Code "B"
(see Model Code 16)

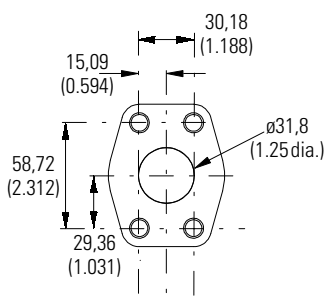
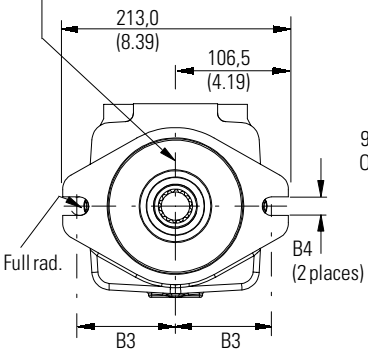

Front outlet port
Code A: SAE J518 4-bolt flange
Code B: ISO 6162 4-bolt flange
Threads:
Code A: 7/16" - 14UNC-2B, 28,4(1.12) min. depth
Code B: M10x1,5, 17,0(0.67) min. depth

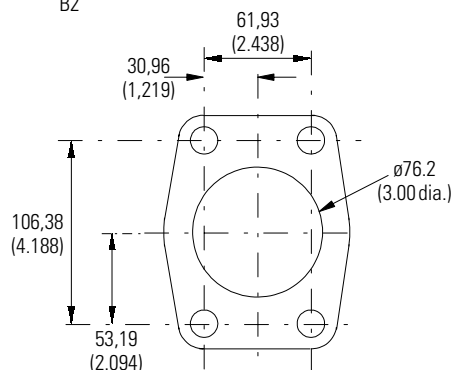
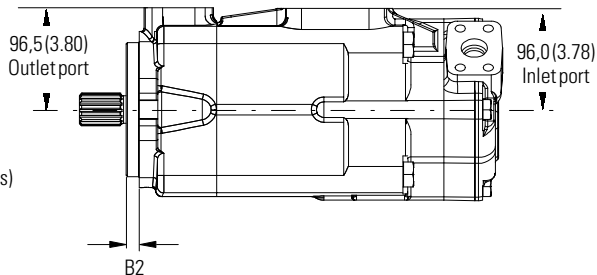

Inlet port
Code A: SAE J518 4-bolt flange
Code B: ISO 6162 4-bolt flange
Threads:
Code A: 5/8" - 11UNC-2B, 30,2(1.19) min. depth
Code B: M16x2,0, 25,4(1.00) min. depth

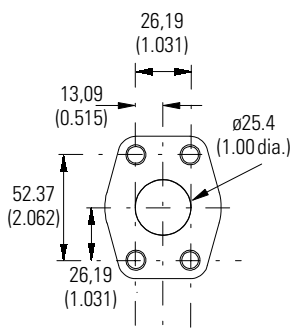

Rear outlet port (view "A-A")
Code A: SAE J518 4-bolt flange
Code B: ISO 6162 4-bolt flange
Threads:
Code A: 3/8" - 16UNC-2B, 22,0(0.87) min. depth
Code B: M10x1,5, 17,0(0.67) min. depth

MODEL CODE 16	FLANGETYPE	ØB1	B2	B3	B4
B	SAE 127-2	126,95/127,00 (4.998/5.000)	12,19/12,70 (0.480/0.500)	90,50 (3.563)	17,37/17,75 (0.684/0.699)
D	ISO 3019/2 125A2HW	124,94/125,00 (4.919/4.921)	9,00/9,50 (0.354/0.374)	90,00 (3.543)	18,00/18,27 (0.709/0.719)

VMQ2 4525

Double Pumps

Installation Dimensions
in mm (in)

For shaft dimensions
see pages 63-66

The inlet/outlet configuration
of the illustration is:

Model code 25 = C

Model code 26 = B

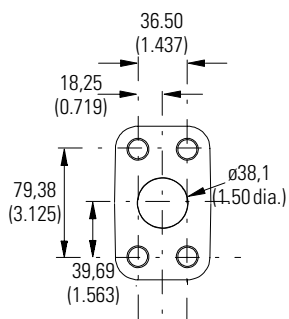
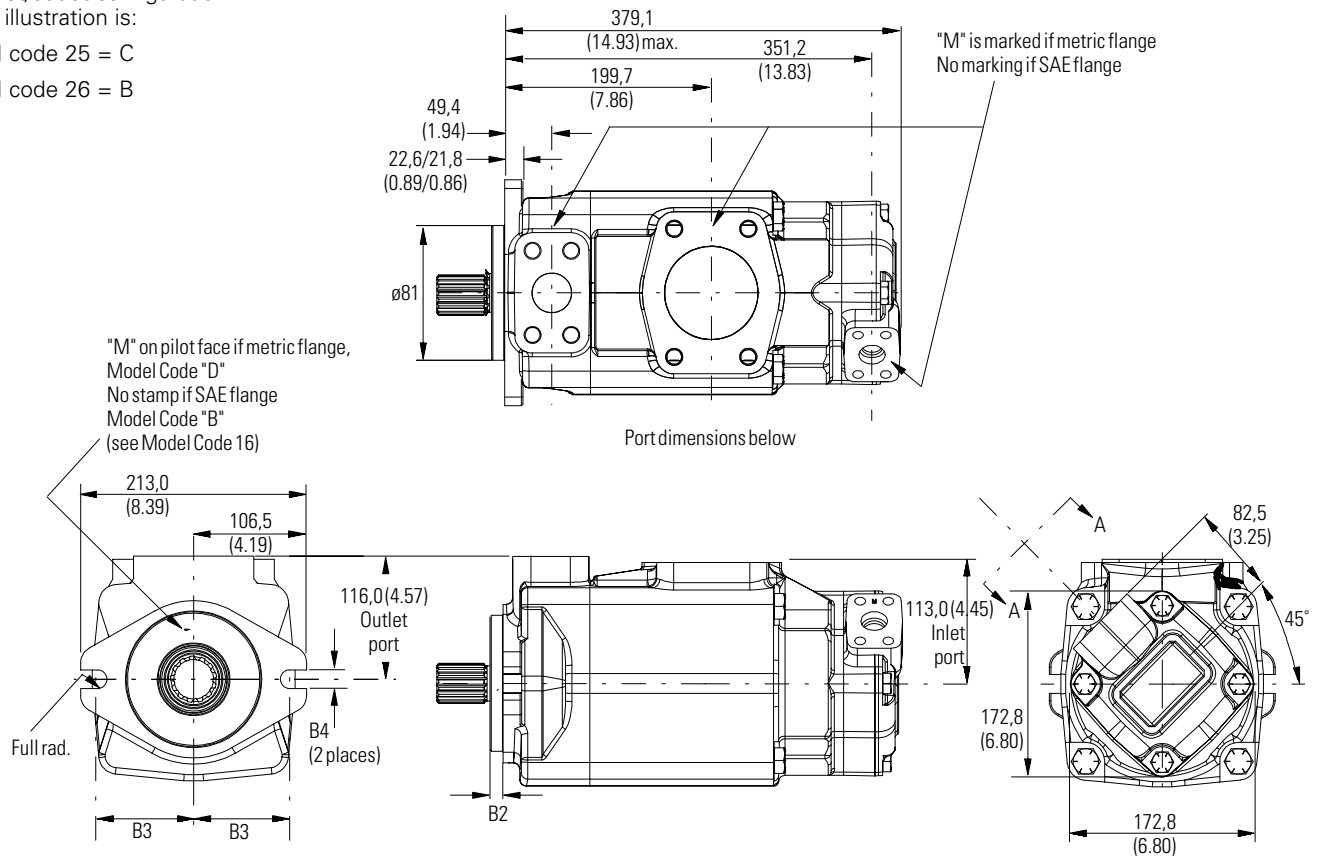
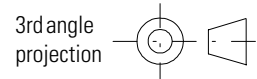

Front outlet port

Code A: SAE J518 4-bolt flange
Code B: ISO 6162 4-bolt flange
Threads:
Code A: 5/8"-11UNC-2B, 35,0(1.38) min. depth
Code B: M16 x 2,0, 25,5(1.00) min. depth

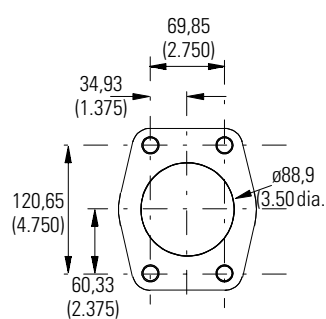

Inlet port

Code A: SAE J518 4-bolt flange
Code B: ISO 6162 4-bolt flange
Threads:
Code A: 5/8"-11UNC-2B, 33,0(1.31) min. depth
Code B: M16 x 2,0, 25,4(1.00) min. depth

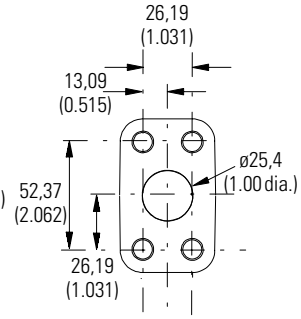

Rear outlet port (view "A-A")

Code A: SAE J518 4-bolt flange
Code B: ISO 6162 4-bolt flange
Threads:
Code A: 5/8"-16UNC-2B, 22,0(0.87) min. depth
Code B: M10 x 1,5, 17,0(0.67) min. depth

MODEL CODE 16	FLANGETYPE	ØB1	B2	B3	B4
B	SAE 127-2	126,95/127,00 (4.998/5.000)	12,19/12,70 (0.480/0.500)	90,50 (3.563)	17,37/17,75 (0.684/0.699)
D	ISO 3019/2 125A2HW	124,94/125,00 (4.919/4.921)	9,00/9,50 (0.354/0.374)	90,00 (3.543)	18,00/18,27 (0.709/0.719)

VMQ2 4535

Double Pumps

Installation Dimensions
in mm (in)

For shaft dimensions
see pages 63-66

The inlet/outlet configuration
of the illustration is:

Model code 25 = C

Model code 26 = B

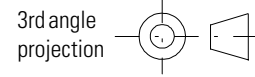

"M" on pilot face if metric flange,
Model Code "D"
No stamp if SAE flange
Model Code "B"
(see Model Code 16)

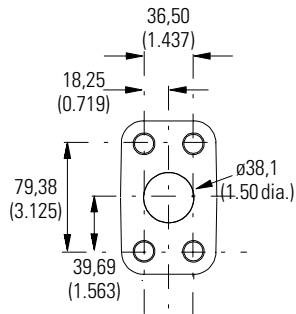
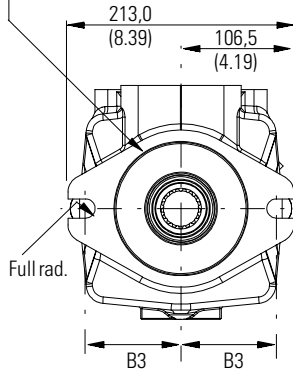
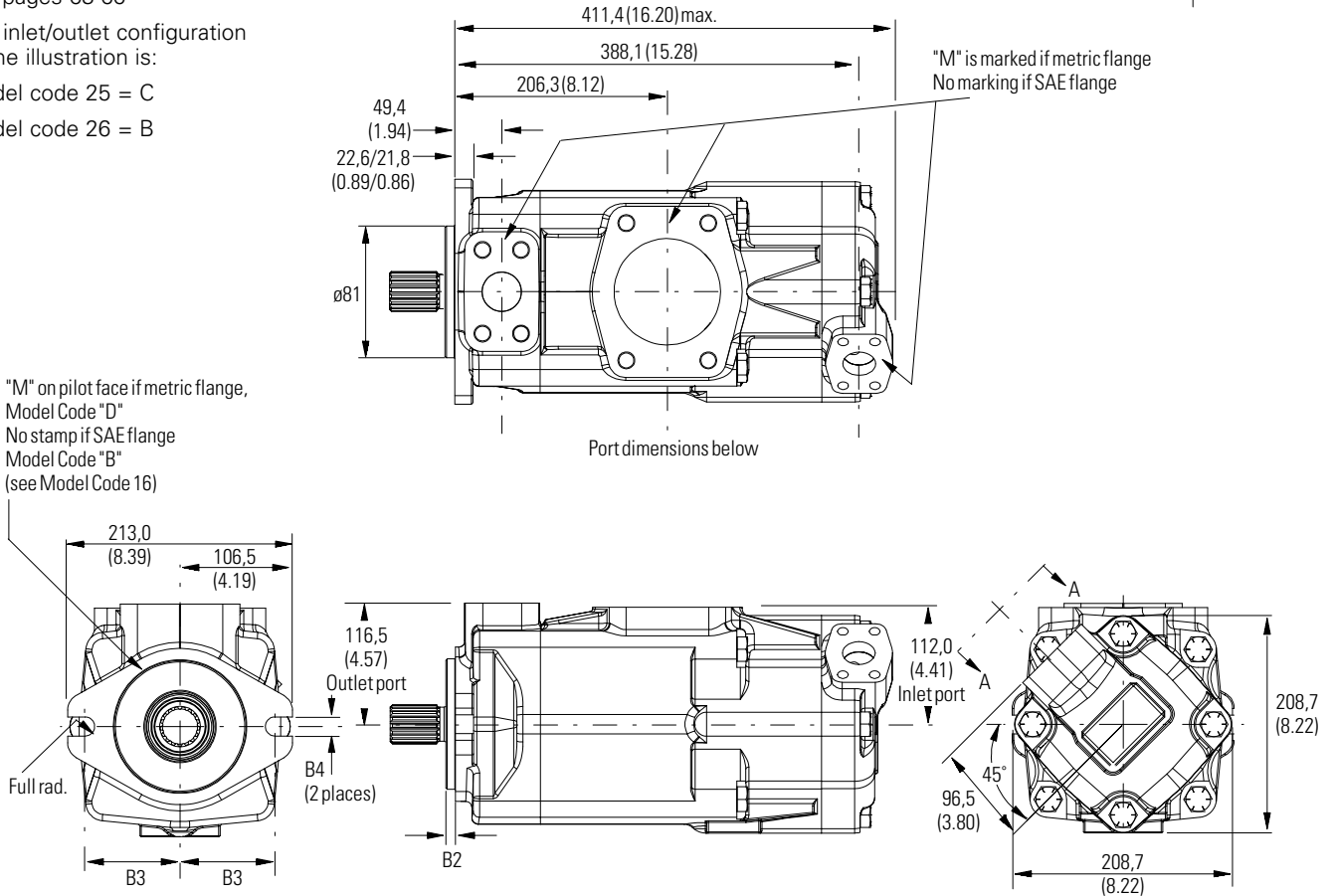

Front outlet port

Code A: SAE J518 4-bolt flange
Code B: ISO 6162 4-bolt flange
Threads:
Code A: 5/8"-11UNC-2B, 35,0(1.38) min. depth
Code B: M16 x 2,0, 25,5(1.00) min. depth

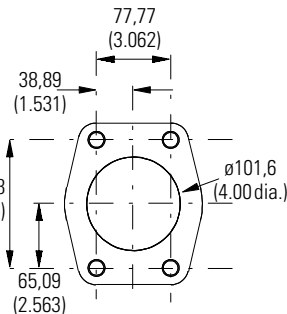

Inlet port

Code A: SAE J518 4-bolt flange
Code B: ISO 6162 4-bolt flange
Threads:
Code A: 5/8"-11UNC-2B, 30,2(1.19) min. depth
Code B: M16 x 2,0, 25,4(1.00) min. depth

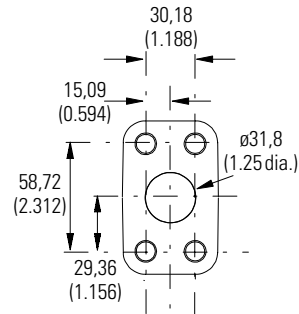

Rear outlet port (view "A-A")

Code A: SAE J518 4-bolt flange
Code B: ISO 6162 4-bolt flange
Threads:
Code A: 5/8"-11UNC-2B, 28,4(1.12) min. depth
Code B: M10 x 1,5, 17,0(0.67) min. depth

MODEL CODE 16	FLANGETYPE	ØB1	B2	B3	B4
B	SAE 127-2	126,95/127,00 (4.998/5.000)	12,19/12,70 (0.480/0.500)	90,50 (3.563)	17,37/17,75 (0.684/0.699)
D	ISO 3019/2 125A2HW	124,94/125,00 (4.919/4.921)	9,00/9,50 (0.354/0.374)	90,00 (3.543)	18,00/18,27 (0.709/0.719)

VMQ3 352525

Triple Pumps

Installation Dimensions
in mm (in)

For shaft dimensions
see pages 63-66

The inlet/outlet configuration
of the illustration is:

Model code 25 = C

Model code 26 = B

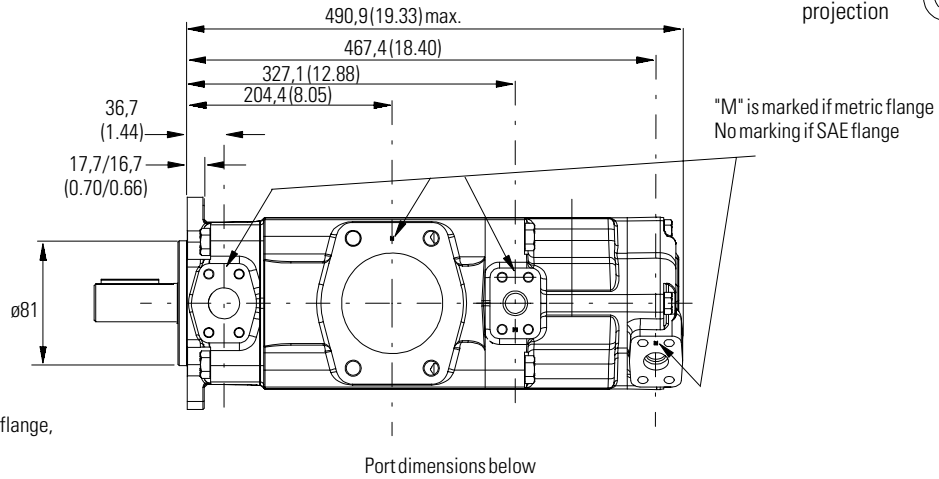
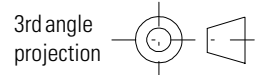

"M" on pilot face if metric flange,
Model Code "B"
No stamp if SAE flange
Model Code "A"
(see Model Code 20)

Port dimensions below

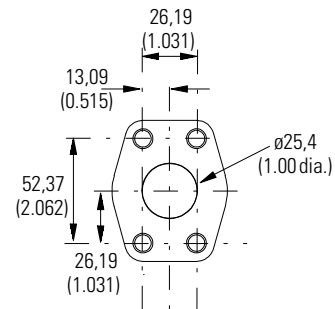
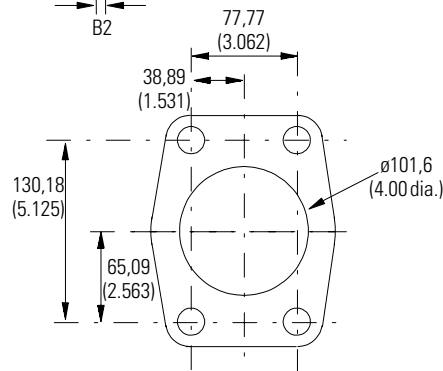
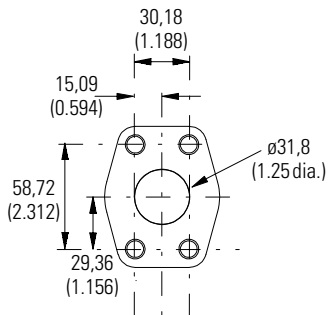
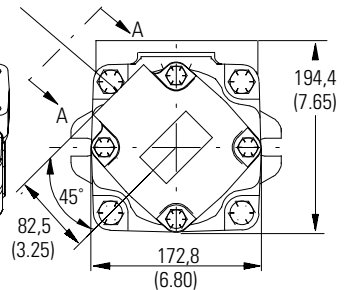
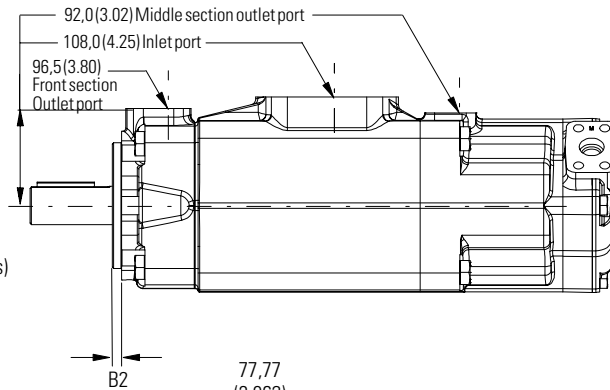
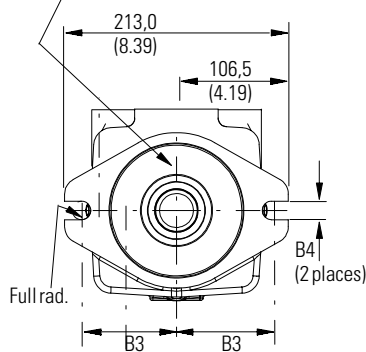

Outlet port, front section

Code A: SAE J518 4-bolt flange
Code B: ISO 6162 4-bolt flange
Threads:
Code A: $\frac{7}{16}$ " -14UNC-2B, 28,4(1.12) min. depth
Code B: M10x1,5, 17,0(0.67) min. depth

Inlet port

Code A: SAE J518 4-bolt flange
Code B: ISO 6162 4-bolt flange
Threads:
Code A: $\frac{5}{8}$ " -11UNC-2B, 30,2(1.19) min. depth
Code B: M16x2,0, 25,4(1.00) min. depth

Outlet port, middle section and outlet port, rear section (view "A-A")

Code A: SAE J518 4-bolt flange
Code B: ISO 6162 4-bolt flange
Threads:
Code A: $\frac{3}{8}$ " -16UNC-2B, 22,0(0.87) min. depth
Code B: M10x1,5, 17,0(0.67) min. depth

MODEL CODE 20	FLANGETYPE	ØB1	B2	B3	B4
A	SAE 127-2	126,95/127,00 (4.998/5.000)	12,19/12,70 (0.480/0.500)	90,50 (3.563)	17,37/17,75 (0.684/0.699)
B	ISO 3019/2 125A2HW	124,94/125,00 (4.919/4.921)	9,00/9,50 (0.354/0.374)	90,00 (3.543)	18,00/18,27 (0.709/0.719)

VMQ3 453525

Triple Pumps

Installation Dimensions
in mm (in)

For shaft dimensions
see pages 63-66

The inlet/outlet configuration
of the illustration is:

Model code 25 = C

Model code 26 = B

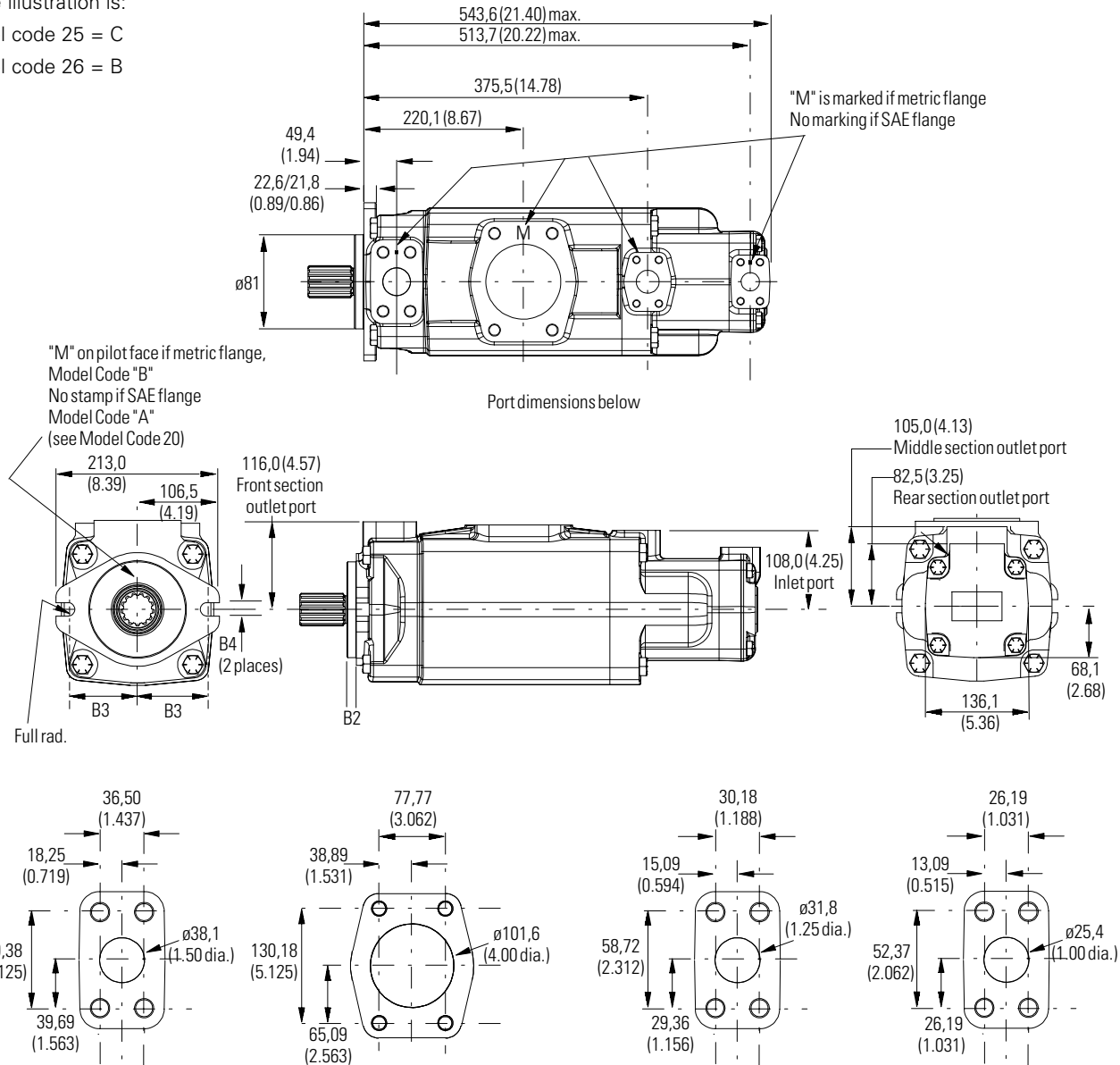
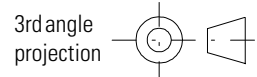

Outlet port, front section

Code A: SAE J518 4-bolt flange
Code B: ISO 6162 4-bolt flange
Threads:
Code A: $\frac{3}{8}$ "-11UNC-2B, 35,0(1.38) min. depth
Code B: M16x2,0, 25,4(1.00) min. depth

Inlet port

Code A: SAE J518 4-bolt flange
Code B: ISO 6162 4-bolt flange
Threads:
Code A: $\frac{3}{8}$ "-11UNC-2B, 30,2(1.19) min. depth
Code B: M16x2,0, 25,4(1.00) min. depth

Outlet port, middle section

Code A: SAE J518 4-bolt flange
Code B: ISO 6162 4-bolt flange
Threads:
Code A: $\frac{7}{16}$ "-14UNC-2B, 28,4(1.12) min. depth
Code B: M10x1,5, 17,0(0.67) min. depth

Outlet port, rear section

Code A: SAE J518 4-bolt flange
Code B: ISO 6162 4-bolt flange
Threads:
Code A: $\frac{3}{8}$ "-16UNC-2B, 22,0(0.87) min. depth
Code B: M10x1,5, 17,0(0.67) min. depth

MODEL CODE 20	FLANGETYPE	ØB1	B2	B3	B4
A	SAE 127-2	126,95/127,00 (4.998/5.000)	12,19/12,70 (0.480/0.500)	90,50 (3.563)	17,37/17,75 (0.684/0.699)
B	ISO 3019/2 125A2HW	124,94/125,00 (4.919/4.921)	9,00/9,50 (0.354/0.374)	90,00 (3.543)	18,00/18,27 (0.709/0.719)

Shaft Options

Straight, Keyed Shafts

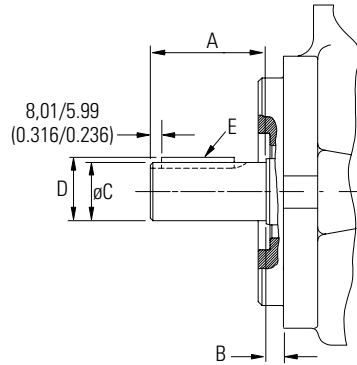

PUMP SIZE	SHAFT CODE	SHAFT DESIGNATION	A	B	ØC	D	E KEY WIDTH X LENGTH
25(T)	01	SAE J744	70,00 (2.756)	8,84/7,22 (0.348/0.284)	25,40/25,36 (1.000/0.998)	28,23/27,99 (1.112/1.102)	6,363 (0.2505) x 49,23 (1.938)
	03	ISO 3019/2	42,00 (1.654)	11,04/9,42 (0.435/0.371)	25,013/24,911 (0.9848/0.9839)	27,97/27,73 (1.102/1.092)	7,982 (0.3142) x 18,00 (0.709)
	05	SAE J744	76,00 (2.992)	8,84/7,22 (0.348/0.284)	31,75/31,71 (1.250/1.248)	35,33/35,09 (1.391/1.381)	7,950 (0.3130) x 50,80 (2.000)
	07	ISO 3019/2	58,00 (2.283)	11,04/9,42 (0.435/0.371)	32,027/32,003 (1.2609/1.2599)	34,99/34,75 (1.378/1.368)	9,982 (0.3930) x 34,00 (1.339)
35(T)	01	SAE J744	76,00 (2.992)	8,81/7,19 (0.347/0.283)	31,75/31,71 (1.250/1.248)	35,33/35,09 (1.391/1.381)	7,950 (0.3130) x 50,80 (2.000)
	03	ISO 3019/2	58,00 (2.283)	11,01/9,39 (0.434/0.370)	32,027/32,003 (1.2609/1.2599)	34,99/34,75 (1.378/1.368)	9,982 (0.3930) x 34,00 (1.339)
	05	SAE J744	83,00 (3.268)	8,81/7,19 (0.347/0.283)	38,10/38,06 (1.500/1.498)	42,40/42,16 (1.665/1.659)	9,538 (0.3755) x 57,15 (2.250)
	07	ISO 3019/2	82,00 (3.228)	11,01/9,39 (0.434/0.370)	40,027/40,003 (1.5759/1.5749)	42,98/42,71 (1.693/1.682)	11,979 (0.4716) x 56,00 (2.205)
45(T)	01	SAE J744	83,00 (3.268)	8,82/7,20 (0.347/0.283)	38,09/38,05 (1.500/1.498)	42,40/42,16 (1.669/1.659)	9,538 (0.3755) x 57,15 (2.250)
	03	ISO 3019/2	82,00 (3.228)	11,02/9,40 (0.434/0.370)	40,027/40,003 (1.5759/1.5749)	43,03/42,79 (1.695/1.685)	11,979 (0.4716) x 56,00 (2.205)
	05	SAE J744	92,00 (3.622)	8,82/7,20 (0.347/0.283)	44,45/44,41 (1.750/1.748)	49,43/49,19 (1.947/1.937)	11,125 (0.4380) x 57,15 (2.250)
2525	01	SAE J744	70,00 (2.756)	8,84/7,22 (0.348/0.284)	25,40/25,36 (1.000/0.999)	28,23/27,99 (1.112/1.102)	6,350 (0.2500) x 49,23 (1.938)
	03	ISO 3019/2	42,00 (1.654)	11,04/9,42 (0.435/0.371)	25,013/24,99 (0.9848/0.9838)	27,97/27,73 (1.102/1.092)	7,964 (0.3135) x 18,00 (0.709)
	05	SAE J744	76,00 (2.992)	8,84/7,22 (0.348/0.284)	31,75/31,71 (1.250/1.248)	35,33/35,09 (1.391/1.381)	7,938 (0.3125) x 50,80 (2.000)
	07	ISO 3019/2	58,00 (2.283)	11,04/9,42 (0.435/0.371)	32,027/32,003 (1.2609/1.2599)	34,99/34,75 (1.378/1.368)	9,964 (0.3923) x 34,00 (1.339)
3525	01	SAE J744	76,00 (2.992)	8,81/7,19 (0.347/0.283)	31,75/31,71 (1.250/1.248)	35,33/35,09 (1.391/1.381)	7,950 (0.3130) x 50,80 (2.000)
	03	ISO 3019/2	58,00 (2.283)	11,01/9,39 (0.434/0.370)	32,027/32,003 (1.2609/1.2599)	34,99/34,75 (1.378/1.368)	9,982 (0.3930) x 34,00 (1.339)
	05	SAE J744	83,00 (3.268)	8,81/7,19 (0.347/0.283)	38,10/38,06 (1.500/1.498)	42,40/42,16 (1.669/1.659)	9,538 (0.3755) x 57,15 (2.250)
	07	ISO 3019/2	81,99 (3.228)	11,02/9,40 (0.434/0.370)	40,037/40,003 (1.5759/1.5749)	42,98/42,71 (1.693/1.682)	11,98 (0.472) x 56,00 (2.205)

Shaft Options (cont.)

Straight, Keyed Shafts (cont.)

PUMP SIZE	SHAFT CODE	SHAFT DESIGNATION	A	B	ØC	D	E KEY WIDTH X LENGTH
4525	01	SAE J744	83,00 (3.268)	8,82/7,20 (0.347/0.283)	38,10/38,06 (1.500/1.498)	42,40/42,16 (1.669/1.659)	9,538(0.3755) x 57,15 (2.250)
	03	ISO 3019/2	82,00 (3.228)	11,02/9,40 (0.434/0.370)	40,27/40,003 (1.5759/1.5749)	43,03/42,79 (1.695/1.685)	11,979 (0.4716) x 56,00 (2.205)
	05	SAE J744	92,00 (3.622)	8,82/7,20 (0.347/0.283)	44,45/44,41 (1.750/1.748)	49,43/49,19 (1.947/1.937)	11,125 (0.4380) x 57,15 (2.250)
4535	01	SAE J744	83,00 (3.268)	8,82/7,20 (0.347/0.283)	38,10/38,06 (1.500/1.498)	42,40/42,16 (1.669/1.659)	9,538 (0.3755) x 57,15 (2.250)
	03	ISO 3019/2	82,00 (3.228)	11,02/9,40 (0.434/0.370)	40,027/40,003 (1.5759/1.5749)	43,03/42,79 (1.695/1.685)	11,979 (0.4716) x 56,00 (2.205)
	05	SAE J744	92,00 (3.622)	8,82/7,20 (0.347/0.283)	44,45/44,41 (1.750/1.748)	49,43/49,19 (1.947/1.937)	11,125 (0.4380) x 57,15 (2.250)
352525	01	SAE J744	76,00 (2.992)	8,81/7,19 (0.347/0.283)	31,75/31,71 (1.250/1.248)	35,33/35,09 (1.391/1.381)	7,950 (0.3130) x 50,80 (2.000)
	03	ISO 3019/2	58,00 (2.283)	11,01/9,39 (0.434/0.370)	32,027/32,003 (1.2609/1.2599)	34,99/34,75 (1.374/1.368)	9,982 (0.3930) x 34,00 (1.339)
	05	SAE J744	83,00 (3.268)	8,81/7,19 (0.347/0.283)	38,10/38,06 (1.500/1.498)	42,40/42,16 (1.669/1.659)	9,538 (0.3755) x 57,15 (2.250)
453525	01	SAE J744	83,00 (3.268)	8,82/7,20 (0.347/0.283)	38,10/38,06 (1.500/1.498)	42,40/42,16 (1.669/1.659)	9,538 (0.3755) x 57,15 (2.250)
	03	ISO 3019/2	82,00 (3.228)	11,02/9,40 (0.434/0.370)	40,027/40,003 (1.5759/1.5749)	43,03/42,79 (1.695/1.685)	11,979 (0.4716) x 56,00 (2.205)
	05	SAE J744	92,00 (3.622)	8,78/7,16 (0.346/0.282)	44,45/44,41 (1.750/1.748)	49,43/49,19 (1.947/1.937)	11,125 (0.4380) x 57,15 (2.250)

Shaft Options (cont.)

Splined Shafts

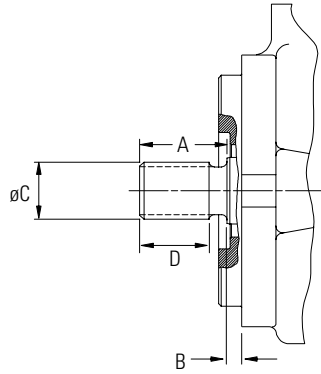

PUMP SIZE	SHAFT CODE	A	B	øC	D	SHAFT TYPE (SEE PAGE 66)
25(T)	02	38,00 (1.496)	8,84/7,22 (0.348/0.284)	24,99 (0.984)	28,00 (1.102)	B-B
	06	48,00 (1.890)	8,84/7,22 (0.348/0.284)	31,22 (1.229)	38,00 (1.496)	C
25	09	33,00 (1.299)	8,84/7,22 (0.348/0.284)	22,23 (0.875)	23,00 (0.906)	B
35(T)	02	48,00 (1.890)	8,81/7,19 (0.347/0.283)	31,22 (1.229)	38,00 (1.496)	C
	06	54,00 (2.126)	8,81/7,19 (0.347/0.283)	37,57 (1.479)	44,00 (1.732)	C-C
45(T)	02	54,00 (2.126)	8,82/7,20 (0.347/0.283)	37,57 (1.479)	44,00 (1.732)	C-C
	06	48,00 (1.890)	8,82/7,20 (0.347/0.283)	43,71 (1.721)	57,00 (2.244)	D
	09	48,00 (1.890)	8,70/7,30 (0.28/0.34)	31,22 (1.229)	38,00 (1.496)	C
2525	02	38,00 (1.496)	8,84/7,22 (0.348/0.284)	24,99 (0.984)	28,00 (1.102)	B-B
	06	48,00 (1.890)	8,84/7,22 (0.348/0.284)	31,22 (1.229)	38,00 (1.496)	C
3525	02	48,00 (1.890)	8,81/7,19 (0.347/0.283)	31,22 (1.229)	38,00 (1.496)	C
	06	54,00 (2.126)	8,81/7,19 (0.347/0.283)	37,57 (1.479)	44,00 (1.732)	C-C
4525	02	54,00 (2.126)	8,82/7,20 (0.347/0.283)	37,57 (1.479)	44,00 (1.732)	C-C
	06	67,00 (2.638)	8,82/7,20 (0.347/0.283)	43,71 (1.721)	57,00 (2.244)	D
	09	48,00 (1.890)	8,70/7,30 (0.28/0.34)	31,22 (1.229)	38,00 (1.496)	C
4535	02	54,00 (2.126)	8,82/7,20 (0.347/0.283)	37,57 (1.479)	44,00 (1.732)	C-C
	06	67,00 (2.638)	8,82/7,20 (0.347/0.283)	43,71 (1.721)	57,00 (2.244)	D
	09	48,00 (1.890)	8,70/7,30 (0.28/0.34)	31,22 (1.229)	38,00 (1.496)	C
352525	02	48,00 (1.890)	8,81/7,19 (0.347/0.283)	31,22 (1.229)	38,00 (1.496)	C
	06	54,00 (2.126)	8,81/7,19 (0.347/0.283)	37,57 (1.479)	44,00 (1.732)	C-C
453525	02	54,00 (2.126)	8,82/7,20 (0.347/0.283)	37,57 (1.479)	44,00 (1.732)	C-C
	06	67,00 (2.638)	8,82/7,20 (0.347/0.283)	43,71 (1.721)	57,00 (2.244)	D

Spline Data

External involute spline tolerance class 7 ANSI B921A-1976
30° pressure angle, flat root,
side fit.

SHAFT TYPE	NO. OF TEETH	PITCH	PITCH DIA.	MAJOR DIA.	FORM DIA.	MINOR DIA. (MAX)	BASE DIA.
B	13	16/32	20,637 (0.8125)	22,23/22,17 (0.875/0.873)	19,02 (0.749)	18,16 (0.715)	17,87 (0.7036)
B-B	15	16/32	23,812 (0.9375)	24,99/24,80 (0.984/0.978)	22,15 (0.872)	21,38 (0.840)	20,62 (0.8119)
C	14	12/24	29,63 (1.1667)	32,22/31,06 (1.229/1.223)	27,48 (1.082)	26,41 (1.040)	25,66 (1.0104)
C-C	17	12/24	35,98 (1.4167)	37,57/37,41 (1.479/1.473)	33,76 (1.329)	32,77 (1.290)	31,16 (1.2269)
D	13	8/16	41,27 (1.6250)	43,71/43,56 (1.721/1.715)	38,13 (1.501)	36,63 (1.442)	35,75 (1.4073)

Torque Loading for Direct Drives

Single Pumps (not thru-drive models)

All listed shafts are satisfactory up to maximum pressures in "Typical performance data" for each series.

Double and Triple Pumps

Where multiple cartridges are to be on-load together, check that the sum of their separate torques, taken from the graph on next page, does not exceed the torque limit in Table 1.

Thru-drive Pumps (VMQ1**T models)

Where both the thru-drive pump and its rear-mounted pump are to be on-load together, check that the sum of the torques generated will never exceed the torque limit in Table 2. Also check that the torque required on the rear-mounted pump never exceeds the thru-drive torque limit in Table 2.

Example:

A VMQ2 3525 135 040 operating at 240 bar (3480 psi) front section and 280 bar (4060 psi) rear section will require over 700 Nm (6196 lb.in) input torque. Therefore, all listed shafts for the VMQ2 3525 will be acceptable.

Table 1
Single, Double and Triple Pumps Shaft Torque Ratings

FRAME SIZE	SHAFT TYPE	TYPE	SAE CODE	SIZE MM	NO. OF TEETH	TORQUE RATING NM	TORQUE RATING (LB.IN.)
25, 2525	01	Keyed		25,40	N/A	407	(3600)
25, 2525	02	Splined	B-B	24,99	15	621	(5500)
25, 2525	03	Keyed		25,00	N/A	407	(3600)
25	09	Splined	B	21,82	13	328	(2900)
25, 2525	05	Keyed		31,75	N/A	814	(7200)
25, 2525	06	Splined	C	31,22	14	814	(7200)
25, 2525	07	Keyed		32,00	N/A	814	(7200)
35, 3525, 352525	01	Keyed		31,75	N/A	814	(7200)
35, 3525, 352525	02	Splined	C	31,22	14	1017	(9000)
35, 3525, 352525	03	Keyed		32,00	N/A	814	(7200)
35, 3525, 352525	05	Keyed		38,10	N/A	1130	(10000)
35, 3525, 352525	06	Splined	C-C	37,57	17	1130	(10000)
35, 3525, 352525	07	Keyed		40,00	N/A	1130	(10000)
45, 45**, 453525	01	Keyed		38,10	N/A	1130	(10000)
45, 45**, 453525	02	Splined	C-C	37,57	17	1808	(16000)
45, 45**, 453525	03	Keyed		40,00	N/A	1130	(10000)
45, 45**, 453525	05	Keyed		44,45	N/A	1638	(14500)
45, 45**, 453525	06	Splined	D	43,71	13	1808	(16000)
45, 45**, 453525	09	Splined	C	31,22	14	1017	(9000)

Table 2
Thru-Drive Pumps Shaft Torque Ratings

PUMP	SHAFT	MAX. INPUT TORQUE NM	MAX. INPUT TORQUE (LB.IN.)	MAX. THRU-DRIVE TORQUE NM	MAX. THRU-DRIVE TORQUE (LB.IN.)
VMQ125T	01	407	(3600)	350	(3100)
	02	621	(5500)	350	(3100)
	03	407	(3600)	350	(3100)
	05	814	(7200)	350	(3100)
	06	814	(7200)	350	(3100)
	07	814	(7200)	350	(3100)
	VMQ135T	01	814	(7200)	678
02		1017	(9000)	678	(6000)
03		814	(7200)	678	(6000)
05		1130	(10000)	678	(6000)
06		1130	(10000)	678	(6000)
07		1130	(10000)	678	(6000)
VMQ145T		01	1130	(10000)	1130
	02	1808	(16000)	1130	(10000)
	03	1130	(10000)	1130	(10000)
	05	1638	(14500)	1130	(10000)
	06	1808	(16000)	1130	(10000)
	09	1130	(10000)	1130	(10000)

Torque Loading for Direct Drives (cont.)

Input Torque Requirement

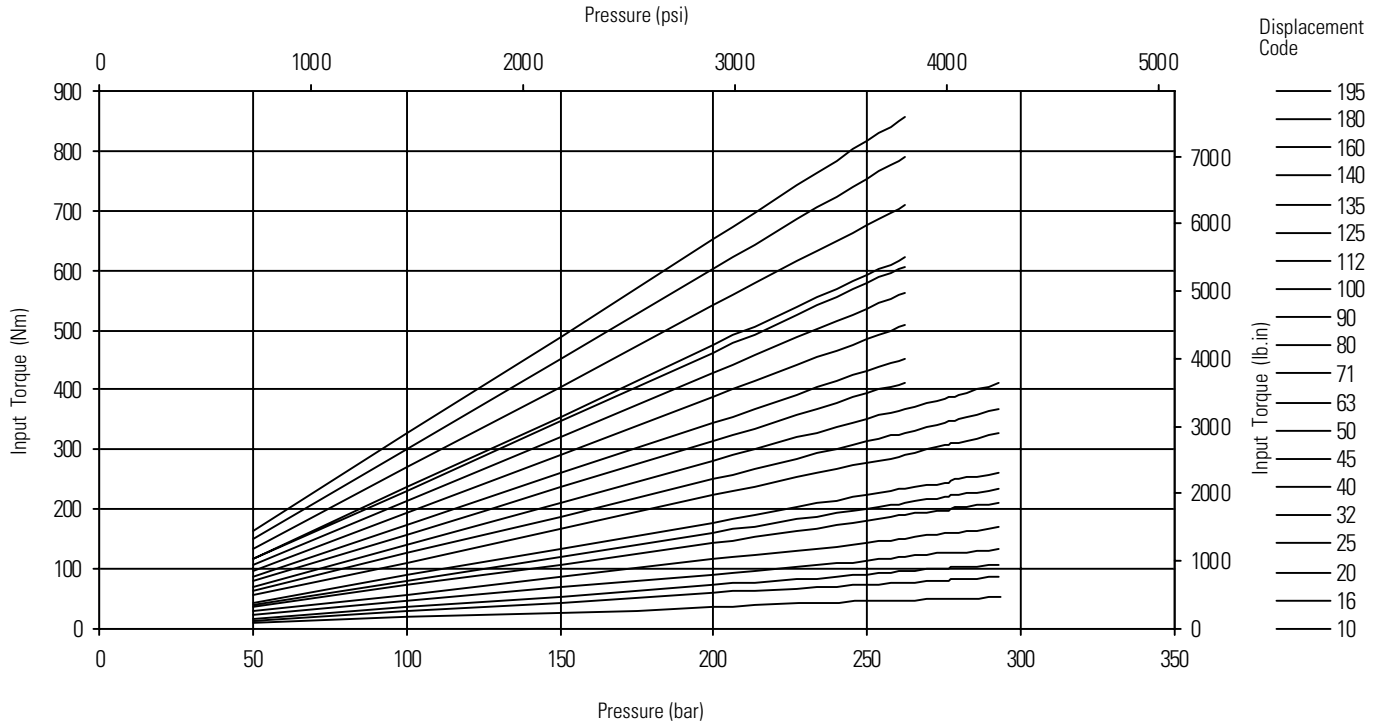

Note

To realize the high input torque levels for keyed shafts (nos. 01, 03, 05 and 07), the corners of the key must be chamfered 0,76 to 1,02 mm (0.030 to 0.040 in) x 45° to clear the radii in the keyway.

(Eaton ships keyed shafts with the corners of the key already chamfered.) Also, the key must be installed in the keyway 8,01/5,99 mm (0.316/0.236 in) back from the end of the shaft as shown on page 66.

Spline shaft ends (nos. 02, 06 and 09) must be lubricated by gearbox lubricant or anti-seizure grease to prevent spline wear and fretting.

Water Glycol Guidelines

VISCOSITY & SPEED REQUIREMENTS

	Minimum Intermittent Viscosity cSt	Minimum Continuous Viscosity cSt	Optimum Operating Viscosity Range cSt	Maximum Viscosity at Full Pressure cSt	Viscosity Range Requiring < 50% Outlet Pressure cSt	Maximum Viscosity at Startup cSt	Maximum/Minimum Operating Speed RPM
Industrial	18	20	20-54	54	54-860	860	1800/900

PRESSURE & OPERATING TEMPERATURE REQUIREMENTS

	Minimum Inlet Pressure Absolute bar (PSI)	Recommended Operating Inlet Pressure - Gage bar (PSI)	Maximum Positive Inlet Pressure - Gage bar (PSI)	Max. Continuous Operating Temperature C (F)	Max. Transient Operating Temperature C (F)	Max. Steady State Outlet Pressure - Gage bar (PSI)	Max. Transient Outlet Pressure (<0.5s) - Gage bar (PSI)
Industrial	0.9 (13.2) 1.0 (14.7)-45VMQ	0 to 0.36 (0 to 5.0)	1.4 (20)	55 (131)	60 (140)	228 (3300)-25VMQ 207(3000)-35&45VMQ	250 (3625)-25VMQ 228 (3300)-35&45VMQ

Fluid Cleanliness Recommendations

Proper fluid condition is essential for long and satisfactory life of hydraulic components and systems. Hydraulic fluid must have the correct balance of cleanliness, materials and additives for protection against wear of components, elevated viscosity and inclusion of air.

Recommendations on contamination control methods and the selection of products to control fluid condition are included in publication 9132 or 561, "Guide to Systemic Contamination Control." The book also includes information on the concept of "ProActive Maintenance." The following recommendations are based on ISO cleanliness levels at 2 µm, 5 µm and 15 µm.

Vickers™ products, as any components, will operate with apparent satisfaction in fluids with higher cleanliness codes than those described. Other manufacturers will often recommend levels above those specified.

Experience has shown, however, that life of any hydraulic components is shortened in fluids with higher cleanliness codes than those listed above. These codes have been proven to provide a long trouble-free service life for the products shown, regardless of the manufacturer.

PRODUCT	SYSTEM PRESSURE LEVEL BAR (PSI)		
	<140 (<2000)	140-210 (2000-3000)	210+ (3000+)
Vane pumps, fixed	20/18/15	19/17/14	18/16/13
Vane pumps, variable	18/16/14	17/15/13	
Piston pumps, fixed	19/17/15	18/16/14	17/15/13
Piston pumps, variable	18/16/14	17/15/13	16/14/12
Directional valves	20/18/15	20/18/15	19/17/14
Proportional valves	17/15/12	17/15/12	15/13/11
Servo valves	16/14/11	16/14/11	15/13/10
Pressure/Flow controls	19/17/14	19/17/14	19/17/14
Cylinders	20/18/15	20/18/15	20/18/15
Vane motors	20/18/15	19/17/14	18/16/13
Axial piston motors	19/17/14	18/16/13	17/15/12
Radial piston motors	20/18/14	19/17/13	18/16/13

Additional Data

Fluid Selection

Fluid in a hydraulic system performs the multiple functions of transmission of power, lubrication of components, and cooling. It is a vital factor in a hydraulic system and proper selection is a necessity for satisfactory operation and life of components.

Basic requirements of a good petroleum oil for hydraulic systems are:

1. sufficient anti-wear additives,
2. proper viscosity at the operating temperature, and
3. adequate rust and oxidation inhibitors.

A good quality fluid from reputable sources will provide these characteristics.

Two specific types of oil meet the requirements of modern hydraulic systems:

- Anti-wear type hydraulic oils that comply with the pump wear tests of ASTM-D-2882
- Automotive crankcase oils having the letter designations "SC", "SD", "SE", "SF" or "SG" per SAE J183 JUN89.

For additional information on the correct viscosity and proper selection of fluids for hydraulic systems, refer to publication 694.

MOMENTS OF INERTIA

PUMP	MOMENT OF INERTIA N*M*SEC ²	(LB*IN*SEC ²)
VMQ125 (10-32 cm ³ /r)	0,00075	(0.0066)
VMQ125 (40-80 cm ³ /r)	0,00103	(0.0091)
VMQ135	0,0025	(0.022)
VMQ145	0,0050	(0.0441)
VMQ22525	0,0019	(0.017)
VMQ23525	0,0043	(0.038)
VMQ24525	0,0059	(0.0522)
VMQ24535	0,0072	(0.0637)
VMQ3352525	0,00403	(0.0354)
VMQ3453525	0,00773	(0.0679)

WEIGHTS

SIZE	KG	(LB)
25	20,4	(45)
35	34,0	(75)
45	54,4	(120)
25T	27,2	(60)
35T	45,4	(100)
45T	63,5	(140)
2525	36,3	(80)
3525	49,9	(110)
4525	72,6	(160)
4535	79,4	(175)
352525	79,4	(175)
453525	102,1	(225)

Additional Data (cont.)

Conversion Factors

TO CONVERT		→ INTO		MULTIPLY BY
← INTO	TO CONVERT		→ DIVIDE BY	
UNIT	SYMBOL	UNIT	SYMBOL	FACTOR
Atmospheres	Atm	bar	bar	1,013250
BTU/hour	Btu/h	kilowatts	kW	0,293071 x 10 ⁻³
Cubic centimetres	cm ³	litres	l	0,001
Cubic centimetres	cm ³	millilitres	ml	1,0
Cubic feet	ft ³	cubic metres	m ³	0,0283168
Cubic feet	ft ³	litres	l	28,3161
Cubic inches	in ³	cubic centimetres	cm ³	16,3871
Cubic inches	in ³	litres	l	0,0163866
Degrees (angle)	°	radians	rad	0,0174533
Fahrenheit	°F	Celsius (centigrade)	°C	■
Feet	ft	metres	m	0,3048
Feet of water	ft H2O	bar	bar	0,0298907
Fluid ounces, UK	UK fl oz	cubic centimetres	cm ³	28,413
Fluid ounces, US	US fl oz	cubic centimetres	cm ³	29,5735
Foot pounds f	ft lbf	joules	J	1,35582
Foot pounds/minute	ft lbf/min	watts	W	81,3492
Gallons, UK	UK gal	litres	l	4,54596
Gallons, US	US gal	litres	l	3,78531
Gallons, US	US gal	cubic inches	in ³	231
Horsepower	hp	BTU/min	BTU/min	42,2
Horsepower	hp	foot pounds/minute	ft lb/min	33,000
Horsepower	hp	kilowatts	kW	0,7457
Inches of mercury	in Hg	millibar	mbar	33,8639
Inches of water	in H2O	millibar	mbar	2,49089
Inches	in	centimetres	cm	2,54
Inches	in	millimetres	mm	25,4
Kilogramme force	kgf	newtons	N	9,80665
Kilogramme f. metre	kgf m	newton metres	Nm	9,80665
Kilogramme f./sq. centimetre	kp/cm ²	bar	bar	0,980665
Metric horsepower*	*	kilowatts	kW	0,735499
Microinches	µin	microns	µm	0,0254
Millimetres of mercury	mm Hg	millibar	mbar	1,33322
Millimetres of water	mm H2O	millibar	mbar	0,09806
Newtons/square centimetre	N/cm ²	bar	bar	0,1
Newtons/square metre	N/m ²	bar	bar	0.00001
Pascals (newtons/sq metre)	Pa	bar	bar	0.00001
Pints, UK	UK pt	litres	l	0,568245
Pints, US	US liq pt	litres	l	0,473163
Pounds (mass)	lb	kilogrammes	kg	0,4536
Pounds/cubic foot	lb/ft ³	kilogrammes/cubic metre	kg/m ³	16,0185
Pounds/cubic inch	lb/in ³	kilogrammes/cubic centimetre	kg/cm ³	0,0276799
Pounds force	lbf	newtons	N	4,44822
Pounds f. feet	lbf ft	newton metres	Nm	1,35582
Pounds f. inches	lbf in	newton metres	Nm	0,112985
Pounds f./square inch	lbf/in ²	bar	bar	0,06894
Revolutions/minute	r/min	radians/second	rad/s	0,104720

Additional Data (cont.)

Conversion Factors (cont.)

TO CONVERT		→ INTO		MULTIPLY BY
UNIT	SYMBOL	UNIT	SYMBOL	FACTOR
Square feet	ft ²	square metres	m ²	0,092903
Square inches	in ²	square metres	m ²	6,4516 x 10 ⁻⁴
Square inches	in ²	square centimetres	cm ²	6,4516

■ °C = 5 (°F - 32)/9

* In German, Pferdestarke (PS)

In French, cheval vapeur (ch) or (CV)

Fluid Power Equivalents

1 bar = 10⁵ N/m²

1 bar = 10 N/cm² = 1 dN/mm²

1 pascal = 1 N/m²

1 litre = 1000 cm³

1 centistoke (cSt) = 1 mm²/s

1 joule = 1 wattsecond (Ws)

1 US gallon = 231 in³

Hertz (Hz) = cycles/second

Atmospheric pressure at sea level = 1,01 bar (14.7 psi).

Atmospheric pressure decreases approximately 0,028 bar (0.41 psi) for each 305m (1000 feet) of elevation to 7015m (23000 feet)

Pressure (bar) = head (m) x 0.1 x specific gravity

Pressure (psi) = head (ft) x 0.433 x specific gravity

Specific gravity of petroleum-based oil is approximately 0.85

Practical Hydraulic Formulae

Geometric flow rate
(pumps and motors) l/min = $\frac{\text{cm}^3/r \times r/\text{min}}{1000}$

USgpm = $\frac{\text{in}^3/r \times r/\text{min}}{231}$

Theoretical shaft torque
(pumps and motors) Nm = $\frac{\text{cm}^3/r \times \text{bar}}{20\pi}$

lbf in = $\frac{\text{in}^3/r \times \text{psi}}{2\pi}$

Hydraulic power kW = $\frac{l/\text{min} \times \text{bar}}{600}$

hp = $\frac{\text{USgpm} \times \text{psi}}{1714}$

Velocity of fluid in pipe m/s = $\frac{l/\text{min} \times 21,22}{D2}$

where D= inside diameter of pipe in mm

ft/s = $\frac{0.048 \times \text{USgpm}}{D2}$

where D= inside diameter of pipe in inches

Volumetric efficiency (pump) = $\frac{\text{Output } l/\text{min (USgpm)}}{\text{Theoretical } l/\text{min (USgpm)}} \times 100$

(motor) = $\frac{\text{Theoretical } l/\text{min (USgpm)}}{\text{Input } l/\text{min (USgpm)}} \times 100$

Overall efficiency = $\frac{\text{Output kW (hp)}}{\text{Input kW (hp)}}$

Notes

Notes

Notes

Eaton
14615 Lone Oak Road
Eden Prairie, MN 55344
USA
Tel: 952 937-9800
Fax: 952 974-7722
www.hydraulics.eaton.com

Eaton
20 Rosamond Road
Footscray
Victoria 3011
Australia
Tel: (61) 3 9319 8222
Fax: (61) 3 9318 5714

Eaton
46 New Lane, Havant
Hampshire PO9 2NB
England
Tel: (44) 23 92 486 451
Fax: (44) 23 92 487 110

