

Technical Information

Directional Control Valve

ECO 80





ECO 80 Directional control valve

Revision history

Table of revisions

Date	Changed	Rev
October 2016	First edition	0101



ECO 80 Directional Control Valve

Contents

General Information

ECO 80 general description..... 5
 ECO 80 LS general features..... 5
 ECO modules..... 5

Technical description

ECO 80 LS with open center EVP (fixed displacement pump) 6
 ECO 80 LS with closed center EVP (variable displacement pump) 6
 ECO 80 LS sectional view 7
 ECO 80 LS technical data..... 8

Safety

Safety in application..... 9
 FMEA – IEC EN 61508..... 9
 Hazard and risk analysis ISO 12100-1/14121 9

Function

EVBS, main spools for flow control..... 10
 EVPX, electrical LS unloading valve..... 10
 EVB, Work Section..... 11
 EVOS, open spool mechanical actuation..... 12
 EVOS, open spool through action..... 13

EVME, Open spool centering

EVME spring centering..... 14
 EVME, detent 03 position..... 14
 EVME, detent 02 position spool to A or B..... 14
 EVME, through action..... 15
 EVME, micro switch NO..... 16

EVOS x EVME, Combinations: Work Port A & Work Port B

Actuation

EVM, Mechanical Actuation..... 18
 Versions available:..... 18
 EVM without adjustment screws..... 18
 EVM with adjustment screws..... 18
 EVC, cover for mechanical actuation..... 19
 EVH, hydraulic actuation..... 19
 Electrical actuation..... 20
 EVHC, Electrical control of ECO..... 20
 EVHCO, On/Off Electrical Control of ECO..... 22

ECO 80 Combinations

Technical characteristics

General..... 25
 EVP, pump side module..... 25
 Pressure relief valve characteristic in EVP..... 25
 EVB, basic modules oil flow characteristics..... 26
 EVB basic modules, open center EVP..... 26
 Oil flow characteristics for EVB..... 27
 PVLP, shock and PVLA, suction valves..... 27
 Oil..... 27
 Mineral oil..... 27

Module selection chart

Mechanical Module selection chart, symbols, description and code numbers..... 28
 EVP, pump side modules, mechanical acting..... 29
 EVB, basic modules, mechanical acting..... 29
 PVLA, suction valve (fitted in EVB), Mechanical and Electrical acting..... 30
 PVLP, shock and suction valve (fitted in EVB), Mechanical and Electrical acting..... 30
 PVLP, shock and suction valve, Mechanical and Electrical acting..... 30



ECO 80 Directional Control valve

Contents

PVLP, shock and suction valve adjustable (fitted in EVB), Mechanical acting..... 30

EVOS, open spool mechanical actuation, Mechanical acting.....31

EVOS, accessory, Mechanical acting..... 31

EVBS, Mechanical flow control spools, Female Extension..... 31

EVBS, Mechanical flow control spools, Female Extension and through acting..... 31

EVBS, Mechanical flow control spools32

EVBS, Mechanical flow control spools, Female Extension and Micro Switch.....33

EVME, OPEN SPOOL CENTERING, Mechanical acting..... 33

EVME, Micro Switch, Mechanical acting..... 33

EVO, end plate, Mechanical and Electrical acting..... 33

EVO, end plate with Lx, Mechanical and Electrical acting.....33

EVT, assembly kit, Mechanical and Electrical acting..... 34

Electrical Module selection chart..... 34

Electrical Module selection chart, symbols, description and code numbers.....35

 EVP, pump side modules, Electrical acting..... 35

 EVPX, electrical LS unloading valve..... 35

 ECO 80, plug for external pilot oil supply..... 35

 EVB, basic modules, Electrical acting..... 36

 EVM, mechanical actuation..... 37

 EVM, accessory..... 37

 EVC, cover for mechanical actuation, assembled on side "A" 37

 EVHC, electrical actuation, assembled on side "A"37

 EVHCO, On/Off electrical actuation, assembled on side "A"37

 EVH, hydraulic actuation, assembled on side "A" 37

 EVBS, Electrical flow control spools..... 37

 EVO, end plate, Mechanical and Electrical acting.....38

 EVO, end plate with Lx, Mechanical and Electrical acting..... 38

 EVT, assembly kit, Mechanical and Electrical acting..... 38

Dimensions

ECO 80.....39

EVM and EVOS Lever positions..... 40

Other operating conditions

Particle content, degree of contamination.....41

Filtration..... 41

 System filters..... 41

ECO 80 Directional Control Valve

General Information

ECO 80 general description

The ECO 80 LS is a hydraulic load sensing proportional valve group designed to give maximum flexibility in design and build concept. The ECO 80 LS is designed as a load sensing directional control valve which will lead to increased machine performance, higher efficiency, reduced cooling requirements and fuel saving compared to conventional directional control valves.

ECO 80 LS general features

- Load sensing directional control:
 - Proportional control of oil flow to a work function
- Modular build concept:
 - Up to 12 basic modules per ECO 80 LS valve group
 - Different, interchangeable spool variants
 - System pressure up to 280 bar
 - Work port pressure up to 320 bar
 - Compact design and installation

ECO modules

EVP, pump side modules

- Built-in pressure relief valve
- Pressure gauge connection
- Versions:
 - Open center version for systems with fixed displacement pumps
 - Closed center version for systems with variable displacement pumps
 - Integrated 25 bar pilot oil supply for hydraulic and electrohydraulic actuation
 - Versions prepared for electrical LS unloading valve

EVB, basic modules

- Interchangeable spools
- Load holding check valve in channel P
- Option for shock and suction valves for port A and B

Actuation modules

The basic module can be fitted with three main different actuation modules:

- Mechanical
- Electrical
- Hydraulic

Technical description

ECO 80 LS with open center EVP (fixed displacement pump)

When the pump is started and the main spools in the individual basic modules (2) are in the neutral position, oil flows from the pump, through connection P, across the pressure adjustment spool (8) to tank. The spring in the pressure adjustment spool determines the pump pressure (stand-by pressure) in neutral.

When one or more of the main spools are actuated, the highest load pressure is fed through the shuttle valve circuit to the spring chamber behind the pressure adjustment spool (8), and completely or partially closes the connection to tank. Pump pressure is applied to the left-hand side of the pressure adjustment spool (8). The pressure relief valve (7) will open should the load pressure exceed the set value, diverting pump flow back to tank.

With a non pressure-compensated basic module incorporating a load drop check valve (3) in channel P, the check valve prevents return oil flow. Please see [ECO 80 LS sectional view](#) on page 7 for better understanding of this example.

ECO 80 LS with closed center EVP (variable displacement pump)

In the closed center version the pressure adjustment spool (8) will only open to tank when the pressure in channel P exceeds the set value of the pressure relief valve (7).

In load sensing systems the load pressure is led to the pump regulator via the LS connection. In the neutral position the pump control sets the displacement so that leakage in the system is compensated for, to maintain the set stand-by pressure.

When a main spool is actuated the pump regulator will adjust the displacement so that the set differential pressure between P and LS is maintained. The pressure relief valve (7) in EVP should be set at a pressure of approx. 30 bar above maximum system pressure (set on the pump or external pressure relief valve).

ECO 80 Directional Control Valve

Technical description

ECO 80 LS sectional view

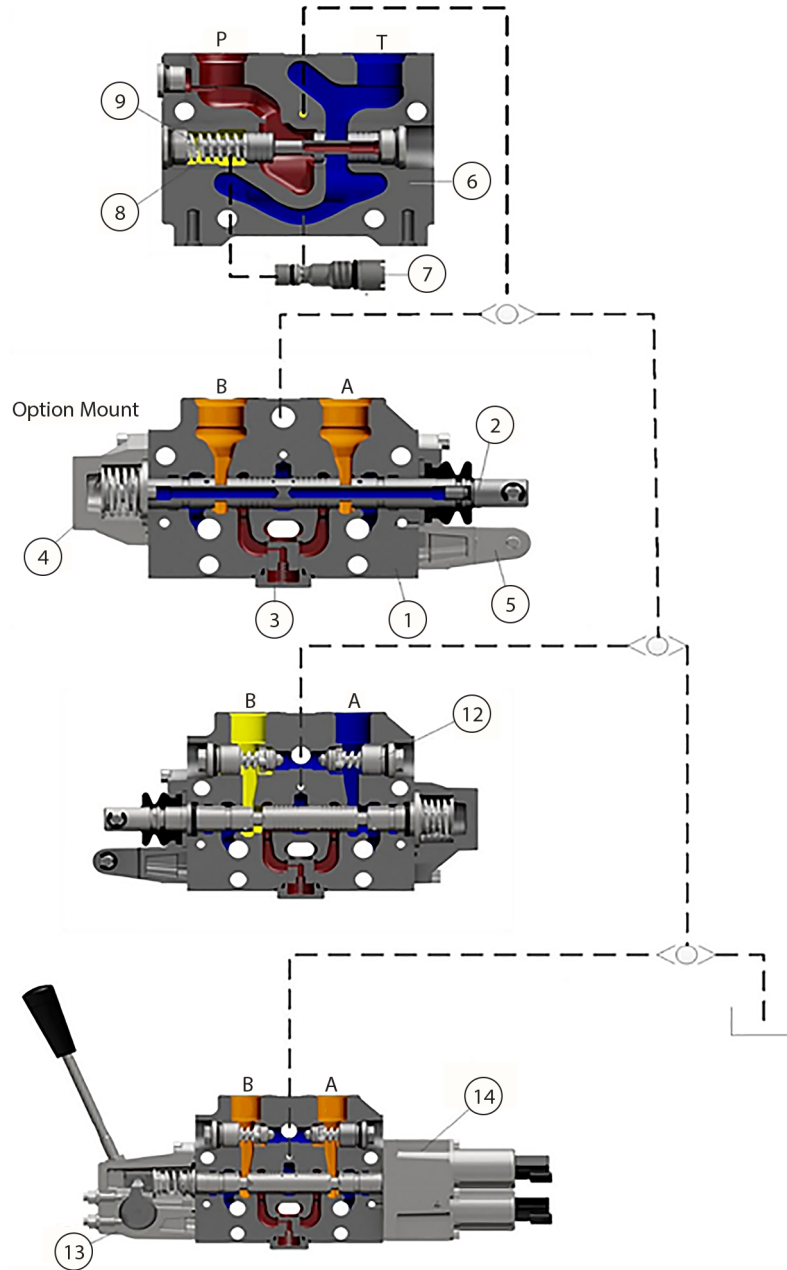

1	Workstation EVB	8	Unloader spool
2	Spool EVBS	9	Unloader spool spring
3	Check valve	10	LS Shuttle
4	Spring center EVME	11	Load sensing
5	Actuator EVOS	12	Shock valve
6	Pump Inlet EVP	13	Spring center (EH) EVM
7	Load sense relief	14	Electric Actuator

ECO 80 Directional control valve

Technical description

ECO 80 LS technical data

The characteristics in this catalog are typical measured values. During measurement, a mineral-based hydraulic oil with a viscosity of 32 mm²/s at a temperature of 55 °C was used.

ECO 80 LS technical data

Maximum pressure	Port P, A/B continuous	280 bar
	Port A/B intermittent	320 bar
	Port T, static / dynamic	25 / 40 bar
Oil flow rated	Port P	80 l/min
	Port A/B	80 l/min
Spool travel, standard		± 5 mm
Dead band, flow control spools		± 1.5 mm
Maximum internal leakage at 70 bar and 32 mm ² /s	A/B → T without shock valve	15 cm ³ /min
	A/B → T with shock valve	20 cm ³ /min
Oil temperature (inlet temperature)	Recommended temperature	30 → 60 °C
	Minimum temperature	-30 °C
	Maximum temperature	+90 °C
Ambient temperature		-30 → 60 °C
Oil viscosity	Operating range	12 - 75 mm ² /s
	Minimum viscosity	4 mm ² /s
	Maximum viscosity	460 mm ² /s
Filtration / maximum contamination according to ISO 4406		23/19/16

ECO 80 Directional Control Valve

Safety

Safety in application

All makes and all types of control valves (including proportional valves) can fail, thus the necessary protection against the serious consequences of function failure should always be built into the system. For each application an assessment should be made for the consequences of pressure failure and uncontrolled or blocked movements. To determine the degree of protection that is required to be built into the application, system tools such as an FMEA (Failure Mode and Effect Analysis) and Hazard and Risk Analysis can be used.

FMEA – IEC EN 61508

FMEA (Failure Mode and Effect Analysis) is a tool used for analyzing potential risks. This analytical technique is utilized to define, identify, and prioritize the elimination or reduction of known and/or potential failures from a given system before it is released for production. Please refer to IEC FMEA Standard 61508.

Hazard and risk analysis ISO 12100-1/14121

This analysis is a tool used in new applications as it will indicate whether there are special safety considerations to be met according to the machine directives EN 13849.

Dependent on the determined levels conformity this analysis will determine if any extra requirements for the product design, development process, production process or maintenance, i.e. the complete product life cycle.

Warning

All makes/brands and types of directional control valves – inclusive proportional valves – can fail and cause serious damage. It is therefore important to analyze all aspects of the application.

Because the proportional valves are used in many different operation conditions and applications, the manufacturer of the application is alone responsible for making the final selection of the products – and assuring that all performance, safety and warning requirements of the application are met.

The process of choosing the control system – and safety levels – is governed by the machine directives EN 13849 (Safety related requirements for control systems).

ECO 80 Directional Control Valve

Function

EVBS, main spools for flow control

When using standard flow control spools, the pump pressure is determined by the highest load pressure. This is done either via the pressure adjustment spool in open center PVP (fixed displacement pumps) or via the pump control (variable displacement pumps).

In this way the pump pressure will always correspond to the load pressure plus the stand-by pressure of the pressure adjustment spool or the pump control. This will normally give optimum and stable adjustment of the oil flow.

EVFX, electrical LS unloading valve

EVFX is a solenoid LS unloading valve. EVFX is fitted into the pump side module enabling a connection to be made between the LS and the tank lines. Thus the LS signal can be relieved to tank by means of an electric signal.

For an EVP pump side module in open center version the relief to tank of the LS signal means that the pressure in the system is reduced to the sum of the tank port pressure plus the neutral flow pressure for the pump side module.

For a EVP pump side module in closed center version the relief to tank of the LS signal means that the pressure is reduced to the sum of the tank port pressure for the pump side module plus the stand-by pressure of the pump.

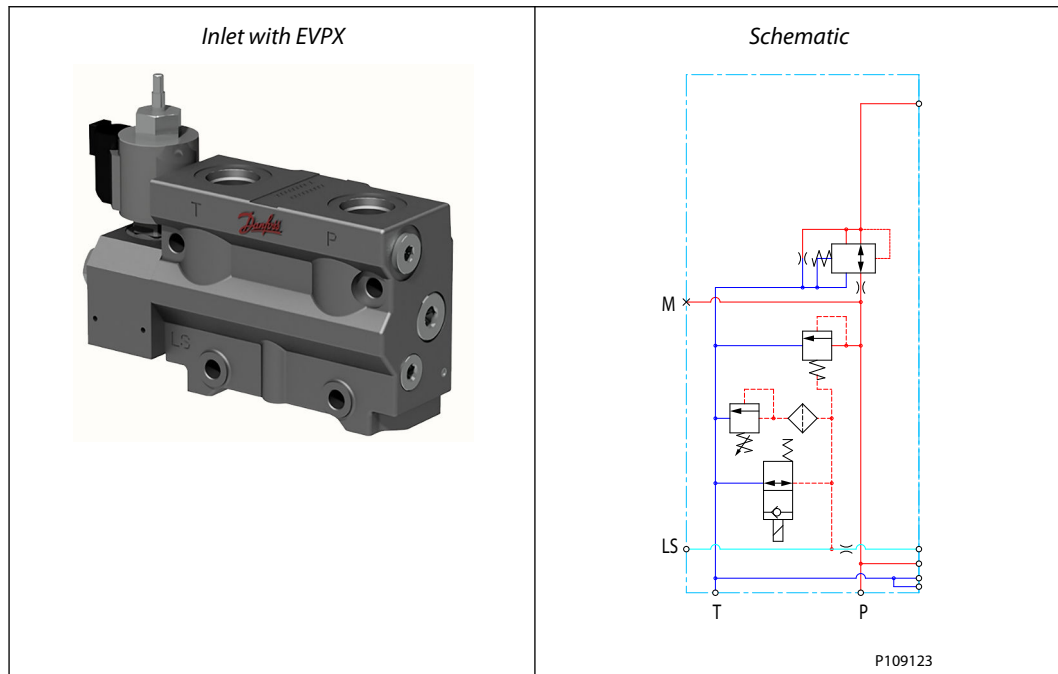

LCO 60 Directional Control Valve

Function

EVB, Work Section

Worksections are available in 2 variants (for mechanical actuation & for hydraulic or electro-hydraulic actuation) and offer 2 options each: A 'low' body including p-channel check valves as well as a 'medium' body including p-channel check valve and shock & anti-cavitation valves. For both worksections all spool options are available.

Low body

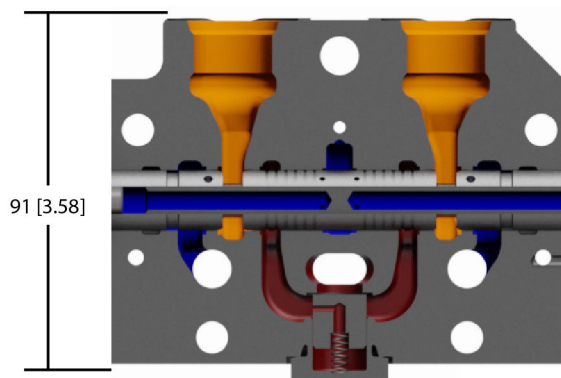

F101 938

Medium body

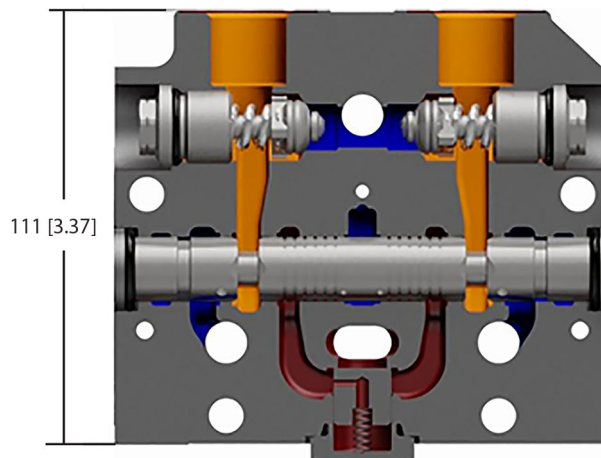

The position of the tie-rods, location of P, T and LS lines are the same in both configurations. This enables that worksections can be built into the same valve stack and can be arranged freely in the valve to enable freedom in machine design.

The work sections does not facilitate possibility for options mounting.



ECO 80 Directional Control Valve

Function

EVOS, open spool mechanical actuation

The EVOS mechanical actuation consists of an aluminum base with a lever and a rubber boot to protect the spool, mounted on the end of the valve slice. When actuating the lever the operator is directly pulling or pushing on the main spool inside the valve hence controlling the flow.

The lever has a travel of 14° in either direction from neutral. Actuating the lever fully will move the spool all 5 mm and give full flow. The lever can be mounted / removed without having to remove the EVOS base.

The EVOS should be used with open spool mechanical actuation and can be combined with any EVME, spring center, detent, through action and micro switch.

mm [in]

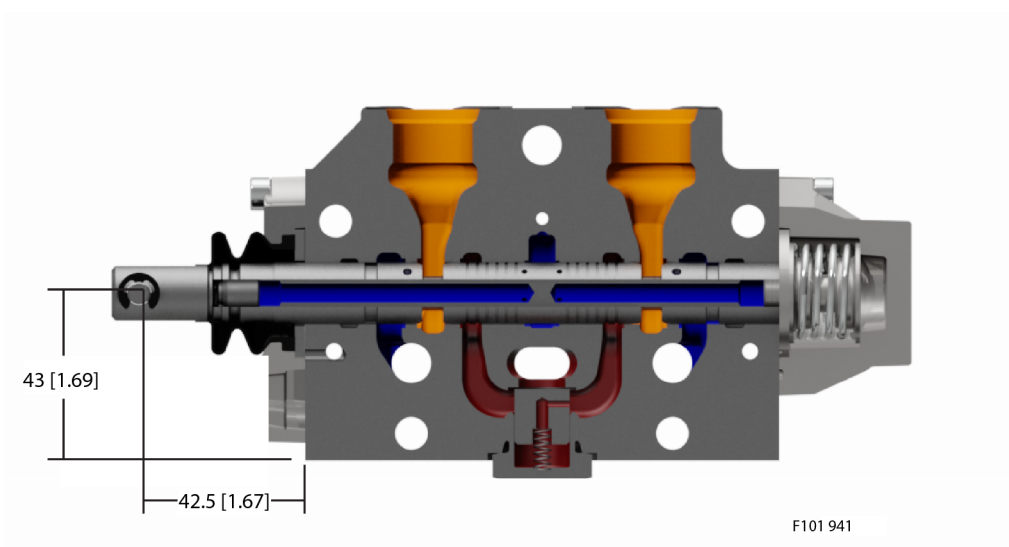

Operating torque for EVOS

<p>F302 525</p>	Spool displacement	Operating torque N•m
		EVOS + EVME (spring center, Micro Switch)
	From neutral position	18 ±1
	Maximum spool travel	29 ±1
	No control lever position	2 x 6 (see pg. 38 EVOS, Lever Position)
Control lever range	±14°	



ECO 80 Directional Control Valve

Function

EVOS, open spool through action

The EVOS open spool through action consists of an aluminum base with a rubber boot to protect the spool, mounted on the end of the valve slice, the connection with application is an female extension assembled on the main spool.

The valve is actuated by directly pulling or pushing the main spool inside the valve hence controlling the flow. Actuating the spool fully will move all 5 mm and give full flow. The EVOS should be used with open spool mechanical actuation and can be combined with any EVME, spring center, detent, through action and micro switch.

mm [in]

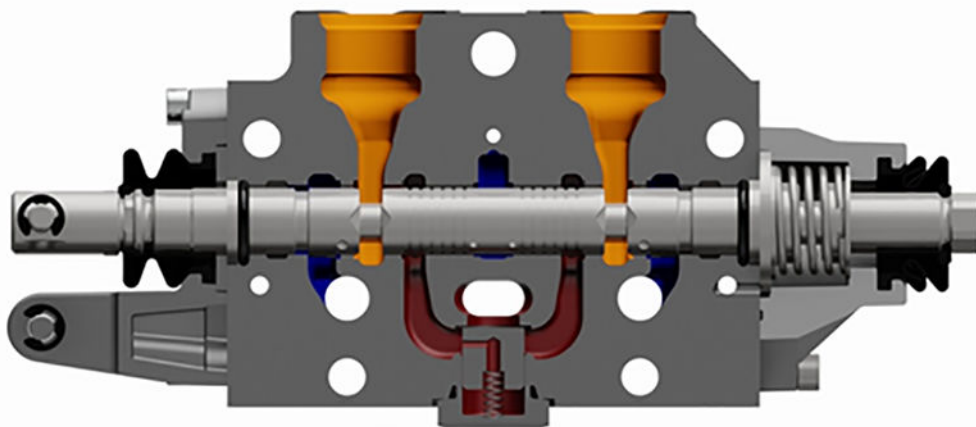

Operation linear force through acting

 <p>F302 526</p>	Spool displacement	Operating linear force
		EVOS + EVME (Through Acting)
	from neutral position	135 ±5 [N]
	maximum spool travel	218 ±5 [N]

Partnumbers EVOS

Description	Partnumber
EVOS80LS-ACTUATOR-MECH	047768
EVOS80LS-ACTUATOR-MECH-LEVER	11175314
ACCESSORIES-BASE MECH-HANDLE	11170923
EVOS80LS-ACTUATOR-THRU	11172533

ECO 80 Directional Control Valve

EVME, Open spool centering

EVME spring centering

The EVME spring centering consists of an aluminum cover mounted on the end of the valve slice which ensures the position of the spool in neutral positions and spool in/out. The EVME spring centering should be used with spool option: Mechanical flow control spools, Female Extension. And can be combined with any EVOS, Open spool actuators.

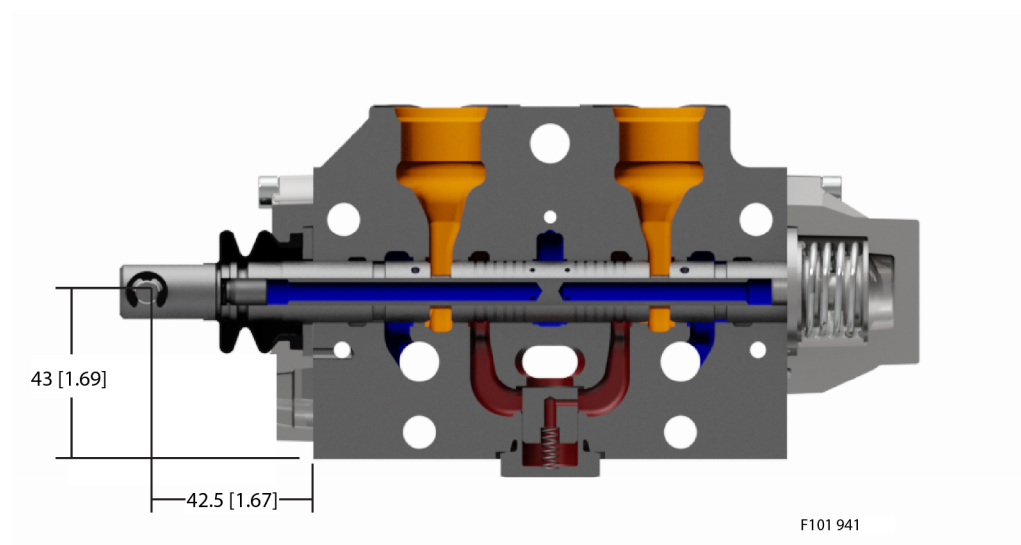

EVME, detent 03 position

The EVME detent 03 positions consists of an aluminum cover mounted on the end of the valve slice which keep the position of the spool in neutral positions and spool in/out.

The EVME detent 03 positions should be used with spool option: Mechanical flow control spools, Female Extension and Detent 03 position. And can be combined with any EVOS, Open spool actuators.

EVME, detent 02 position spool to A or B

The EVME detent 02 positions consists of an aluminum cover mounted on the end of the valve slice which keep the position of the spool in neutral positions and spool out, position spool in is blocked.

The EVME detent 02 positions should be used with spool option: Mechanical flow control spools, Female Extension and Detent 03 position with accessory part number 11173406. And can be combined with any EVOS, Open spool actuators.



LCV 80 Directional Control Valve

EVME, Open spool centering

EVME, through action

The EVME through action consists of an aluminum cover with a rubber boot to protect the spool, mounted on the end of the valve slice which ensures the position of the spool in neutral positions and spool in/out.

The connection with application is a female thread M8 x 1,25 and is it possible to assemble an female extension as accessory part number 050548 on the thread.

The valve is actuated by directly pulling or pushing the main spool inside the valve hence controlling the flow. Actuating the spool fully will move all 5 mm and give full flow. The EVME through action should be used with spool option: Mechanical flow control spools, Female Extension and through acting. Can be combined with any EVOS, Open spool actuators.

Partnumbers EVME

Description	Partnumber
EVME80LS-COVER	11169579
EVME80LS-COVER-THRU	11169580
ACCESSORY-EXTENSION	050548
ACCESSORY-DETENT 02 POSITION	11173406



EVOS 80 Directional control valve

EVME, Open spool centering

EVME, micro switch NO

The EVME Micro Switch consists of an aluminum cover mounted on the end of the valve slice, which enables by two micro switches know which side the spool is being stroked, in or out.

The micro switches can have contacts in the configuration normally open "NO". The EVME Micro Switch should be used with spool option: Mechanical flow control spools, Female Extension and Micro Switch. And can be combined with any EVOS, Open spool actuators.

Technical data for EVME Micro Switch

EVME	Parameter	Voltage	
		12 V	24 V
	Max. current	10 A	
	Resistance	0.010 Ω ± 15%	

Enclosure

Connector type	Protection class
DEUTSCH DT04-2P	IP 67

Partnumbers EVME-DIRECTIONAL INDICATOR

Description	Partnumber
EVOS80LS-COVER-THRU-DI-NO-DT	11170841



ECO 60 Directional Control Valve

EVOS x EVME, Combinations: Work Port A & Work Port B

EVOS x EVME, Combinations

			Work Port B					
			EVOS, Open spool mechanical actuation			EVME, Open spool centering		
			047768 ACTUATOR- MECH	11175314 ACTUATOR- MECH-LEVER	11172533 ACTUATOR- THRU	11169579 COVER (Spring center, detent 02 and 03 positions)	11169580 COVER-THRU	11170841 Micro Switch COVER-THRU- DI-NO-DT
Work Port A	EVME, Open spool centering	11169579 COVER (Spring center, detent 02 and 03 positions)	X	X	X			
		11169580 COVER-THRU	X	X	X			
		11170841 Micro Switch COVER-THRU- DI-NO-DT	X	X	X			
	EVOS, Open spool mechanical actuation	047768 ACTUATOR- MECH				X	X	X
		11175314 ACTUATOR- MECH-LEVER				X	X	X
		11172533 ACTUATOR- THRU				X	X	X

ECC 60 Directional control valve

Actuation

EVM, Mechanical Actuation

The EVM consists of an aluminum base with a lever mounted on the end of the valve slice on side B. When actuating the lever the operator is directly pulling or pushing on the main spool inside the valve hence controlling the flow.

The lever has a travel of 13.8° in either direction from neutral. Actuating the lever fully will move the spool all 5 mm and give full flow. The lever can be mounted / removed without having to remove the EVM base. The EVM should be used with Electrical flow control spools and can be combined with any EVHC or EVH.

Versions available:

EVM without adjustment screws

The standard EVM without adjustment screws will allow a spool travel of 5 mm in either direction. Full lever movement to one side will give full flow to the work ports. When the spool is moved 5mm it will stop due to a mechanical limitation build into the EVM base.

EVM with adjustment screws

The spool travel in either direction can be limited by the adjustment screws. This will limit the flow out of the work ports thereby reducing the speed of an application.

The spool travel is adjusted by first loosening the nut then adjusting the pin screw. After adjustment the nut must be tightened again applying 8 ±1 [N·m] of torque.

Operating torque for EVM

EVM	Spool displacement	Operating torque
		EVM + EVHC & EVM + EVH
	from neutral position maximum spool travel	19 ±1 [N·m]
		55 ±1 [N·m]
	No control lever position	2 x 6
	Control lever range	±13.8°

No control lever position	2 x 6
Control lever range	±13.8°

Partnumbers EVM

Description	Part number
EVM-ACTUATOR	11119157
EVM-ACTUATOR-LEVER	11167001
EVM-ACTUATOR-ADJ SCREW	11145204
EVM-ACTUATOR-ADJ SCREW-LEVER	11167002



LCO 60 Directional Control Valve

Actuation

EVC, cover for mechanical actuation

The EVC is an aluminum plate mounted on the end of the valve slice on side A for purely mechanically operated valve with EVM style.

The EVC is to be combined with an EVM.



Ordering information

Description	Part number
EVC-COVER	11171318

EVH, hydraulic actuation

The EVH is an aluminum plate with two threaded connections mounted on the end of the valve slice on side A. When applying pressure through one of the ports, one side of the spool is pushed to one direction hence flow is coming from the work ports.

The EVH is to be combined with an EVM.

Technical data for EVH

	Control range pressure	5 – 18 bar
	Maximum pilot pressure	35 bar
	Maximum pressure on port T (the hydraulic remote control lever should be connected directly to tank.)	10 bar

Partnumbers EVH

Description	Partnumber
EVH-ACTUATOR-SAE	11169487
EVH-ACTUATOR-BSP	11169486



Actuation

Electrical actuation

EVHC, Electrical control of ECO

The EVHC consists of an aluminum base with two solenoids pressure reducing valves mounted on the end of the valve slice. When actuating with electrical proportional actuation, the main spool position is adjusted so that its position corresponds to an electrical control signal.

The control signal is converted into a hydraulic pressure signal that moves the main spool in the EVB. This is done by means of two proportional pressure-reducing valves. The electrical actuator can be controlled either by a current amplifier card, or directly from a programmable microcontroller.

EVHC actuation module

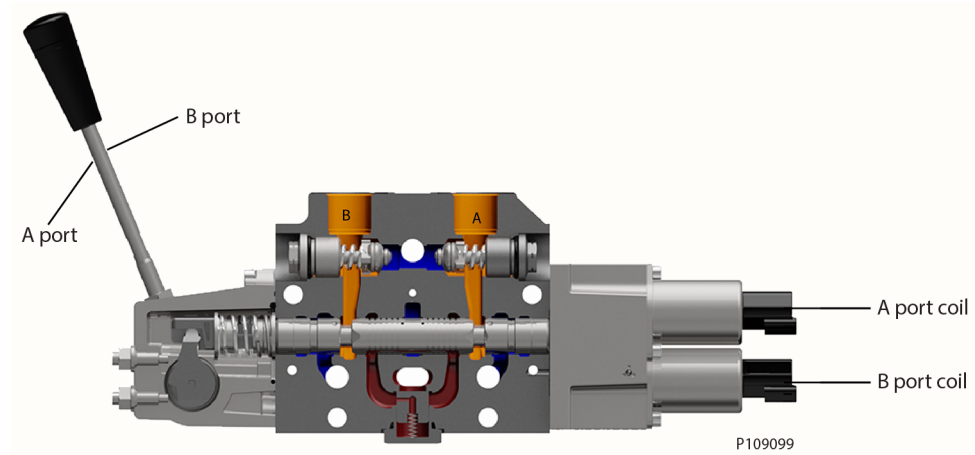

The actuator controls the spool by building up pilot oil pressure on the end of the spool. For the EVHC is necessary a pilot oil pressure between 25 and 30 bar.

The EVHC should be used with Electrical FLOW CONTROL spools and can be combined with any EVM.

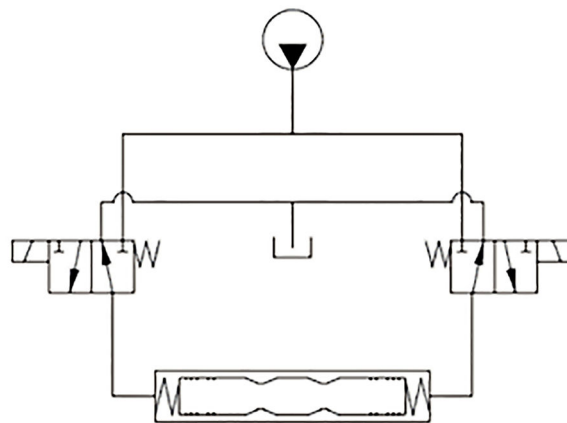

ECO 60 Directional Control Valve

Actuation

Technical data for EVHC

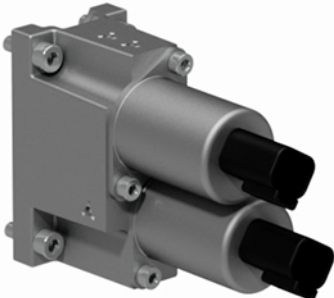
EVHC	Parameter	Control range	
		12 V	24 V
 <p style="text-align: right; margin-right: 50px;">F302 530</p>	Controller output current range	0 -1500 mA	0 - 750 mA
	Pressure control range	8 to 23 bar	
	Resistance	4.75 Ω \pm 5%	20.8 Ω \pm 5%
	Frequency	100 - 400 Hz	

Enclosure

Connector type	Protection class
DEUTSCH DT04-2P	IP 67

EVHC characteristic - Spool stroke vs current



EVHC current response and hysteresis @ 25 bar Pp, 32 cts, 55 °C. The ideal curve (red line) is determined by the main spool neutral spring. The EVHC hysteresis is around $\pm 7,5\%$ (grey region).

The hysteresis is affected by viscosity, friction, flow forces, dither frequency and modulation frequency. The spool position will shift when conditions are changed e.g. temperature change.

Partnumbers EVHC

Description	Partnumber
EVHC-ACTUATOR-DT-12V	11162297
EVHC-ACTUATOR-DT-24V	11162298



Actuation

EVHCO, On/Off Electrical Control of ECO

The EVHCO consists of an aluminum base with two solenoid valves mounted on the end of the valve slice. When active with electrical signal the main spool goes straight to end of stroke, A or B side.

The electrical signal is converted into a hydraulic pressure signal that moves the main spool in the EVB. This is done by means of two on/off solenoid valves.

EVHCO actuation module

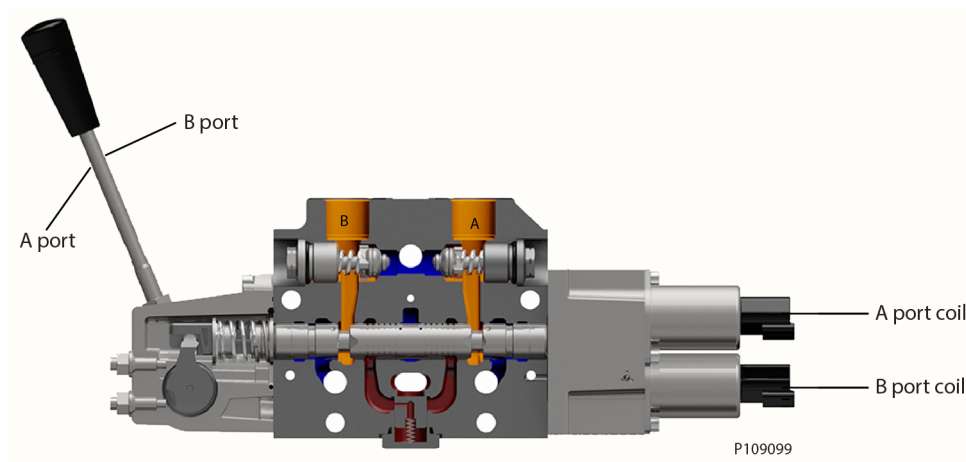

The actuator controls the spool by building up pilot oil pressure on the end of the spool. For the EVHCO is necessary a pilot oil pressure between 25 and 30 bar.

The EVHCO should be used with Electrical FLOW CONTROL spools and can be combined with any EVM.

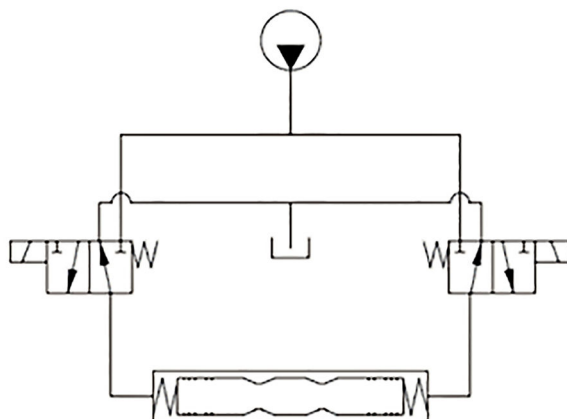



ECO 60 Directional Control Valve

Actuation

Technical data for EVHCO

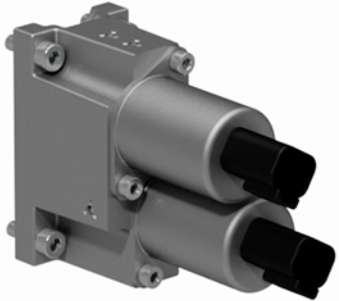
EVHCO	Parameter	Control range	
		12 V	24 V
 <p>F302 530</p>	Pressure control range	25 to 30 bar	
	Resistance at 20 °C	8.15 Ω ± 5%	32.5Ω ± 5%
	Duty Cycle	100%	
	Reaction time from neutral position to max. spool travel	-	Max. 0.300 s

Enclosure

Connector type	Protection class
DEUTSCH DT04-2P	IP 67

Ordering information EVHCO

Description	Part number
EVHCO-ACTUATOR-DT-12V	11179573
EVHCO-ACTUATOR-DT-24V	11179572



ECO 80 Directional Control Valve

ECO 80 Combinations

In ECO 80 it is possible for the same valve group to have the combination of all actuations type. It is necessary to have the same group combination of EVM and EVOS to keep the sequence: EVM + EVOS, this sequence is from the inlet.

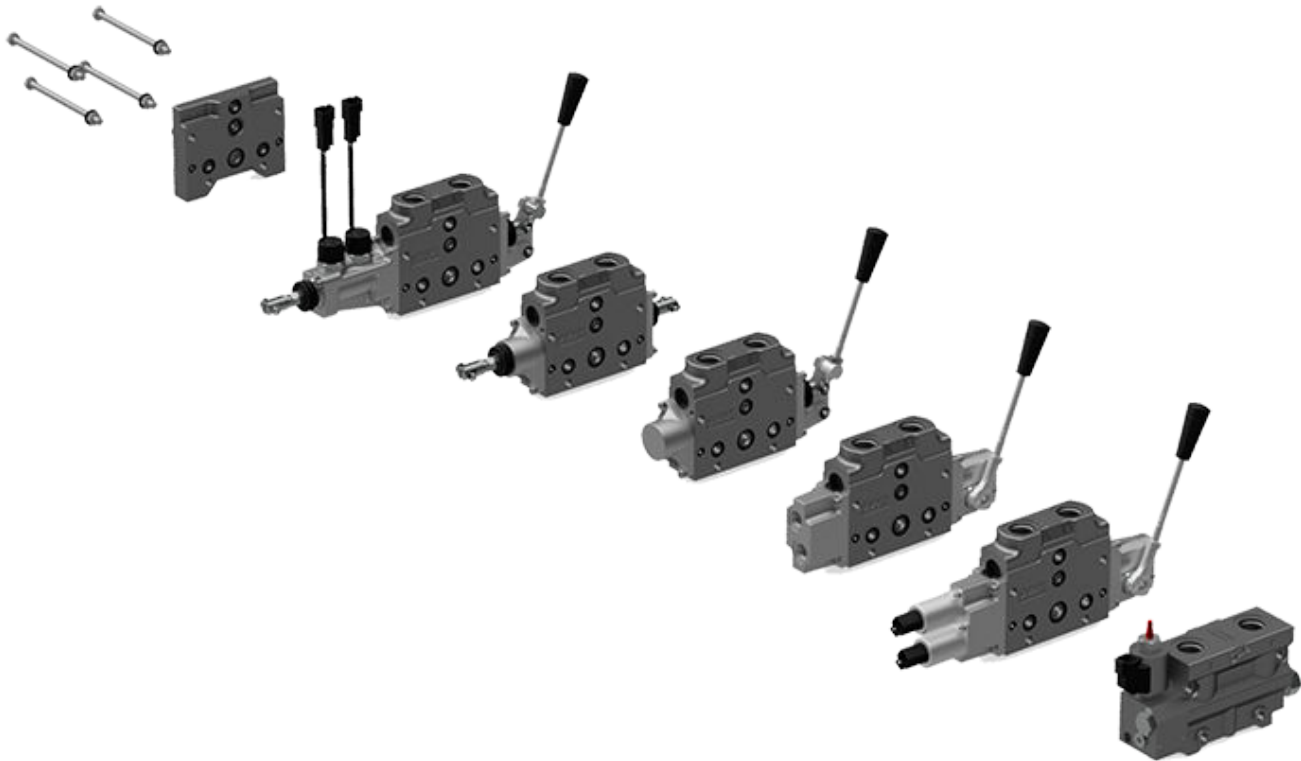

LCO 80 Directional Control Valve

Technical characteristics

General

The characteristics in this catalog are typical measured values. During measuring, a mineral based hydraulic oil with a viscosity of 32 mm²/s at a temperature of 50°C was used.

EVP, pump side module

Pressure relief valve characteristic in EVP

The pressure relief valve is set at an oil flow of 5 l/min. Setting range: 50 to 280 bar

Pressure relief valve Characteristic

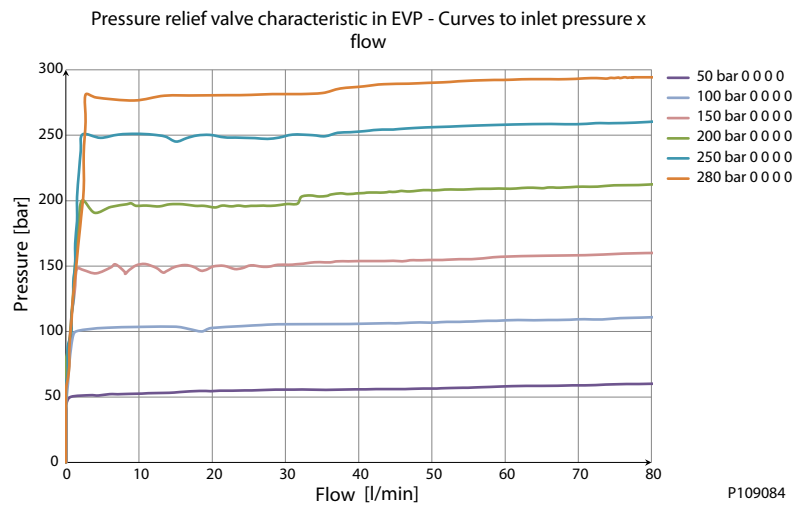

Neutral by-pass pressure drop characteristic (open center)

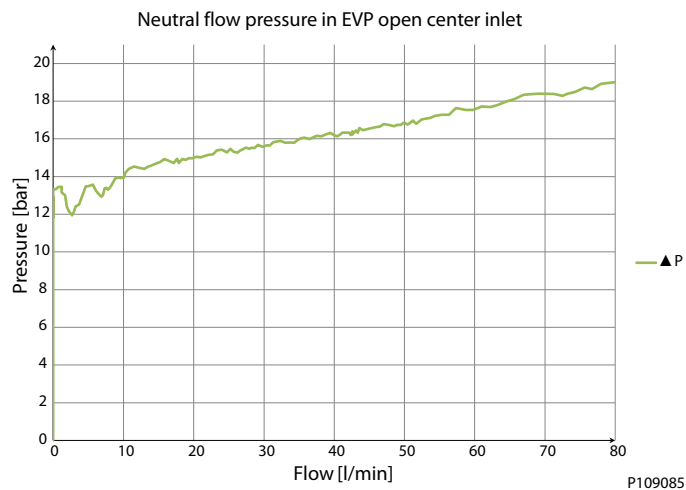

ECO 80 Directional Control Valve

Technical characteristics

EVB, basic modules oil flow characteristics

The oil flow for the individual spool depends on:

- Type of pump (fixed or variable displacement).

EVB basic modules, open center EVP

The spool flow is dependent on the supplied oil flow, QP.

The characteristics apply to supply oil flow of 80 l/min with the actuation of one basic module and the supply flow level.

If several basic modules are activated at the same time, the characteristic depends on the load pressure of the actuated basic modules.

Oil flow as a function of spool travel characteristic (all spools sizes)

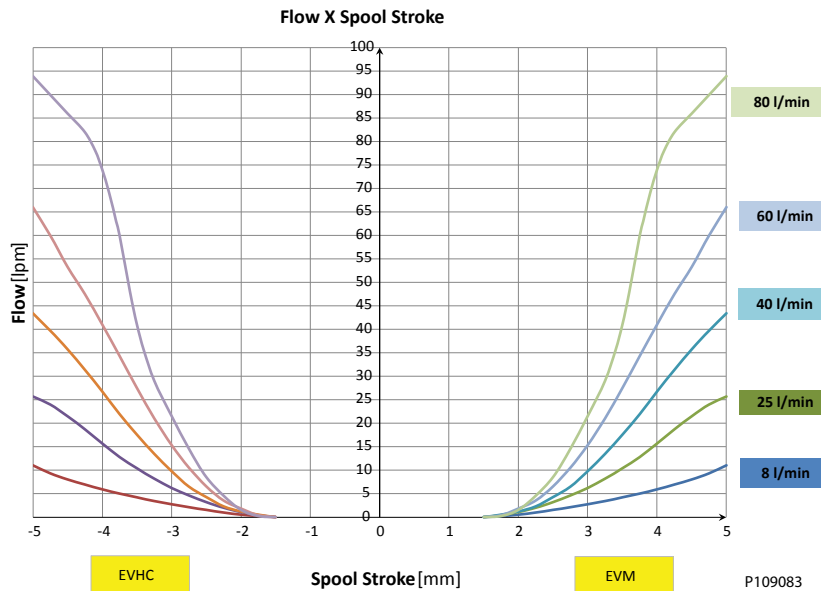



ECO 80 Directional Control Valve

Technical characteristics

Oil flow characteristics for EVB

Pressure drop test at maximum spool travel (A/B-T)

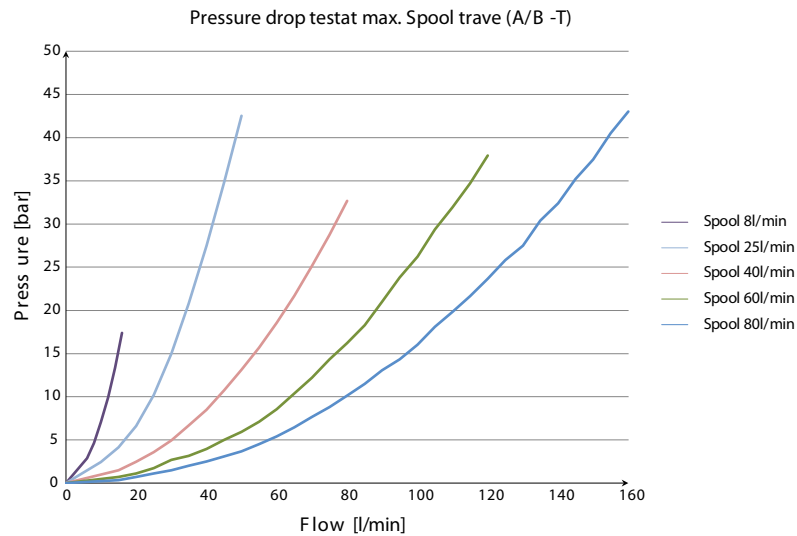

P109082

PVLP, shock and PVLA, suction valves

For more information, see *PVG 32 Technical Information*, [520L0344](#) for detailed information on PVLP, shock and PVLA, suction valves

Oil

The main duty of the oil in a hydraulic system is to transfer energy; but it must also lubricate the moving parts in hydraulic components, protect them against corrosion, and transport dirt particles and heat out of the system. It is therefore important to choose the correct oil with the correct additives. This gives normal operation and long working life.

Mineral oil

For systems with ECO 80 LS valves Danfoss recommends the use of mineral-based hydraulic oil containing additives: Type HLP (DIN 51524) or HM (ISO 6743/4).



EVO 60 Directional Control Valve

Module selection chart

Mechanical Module selection chart, symbols, description and code numbers

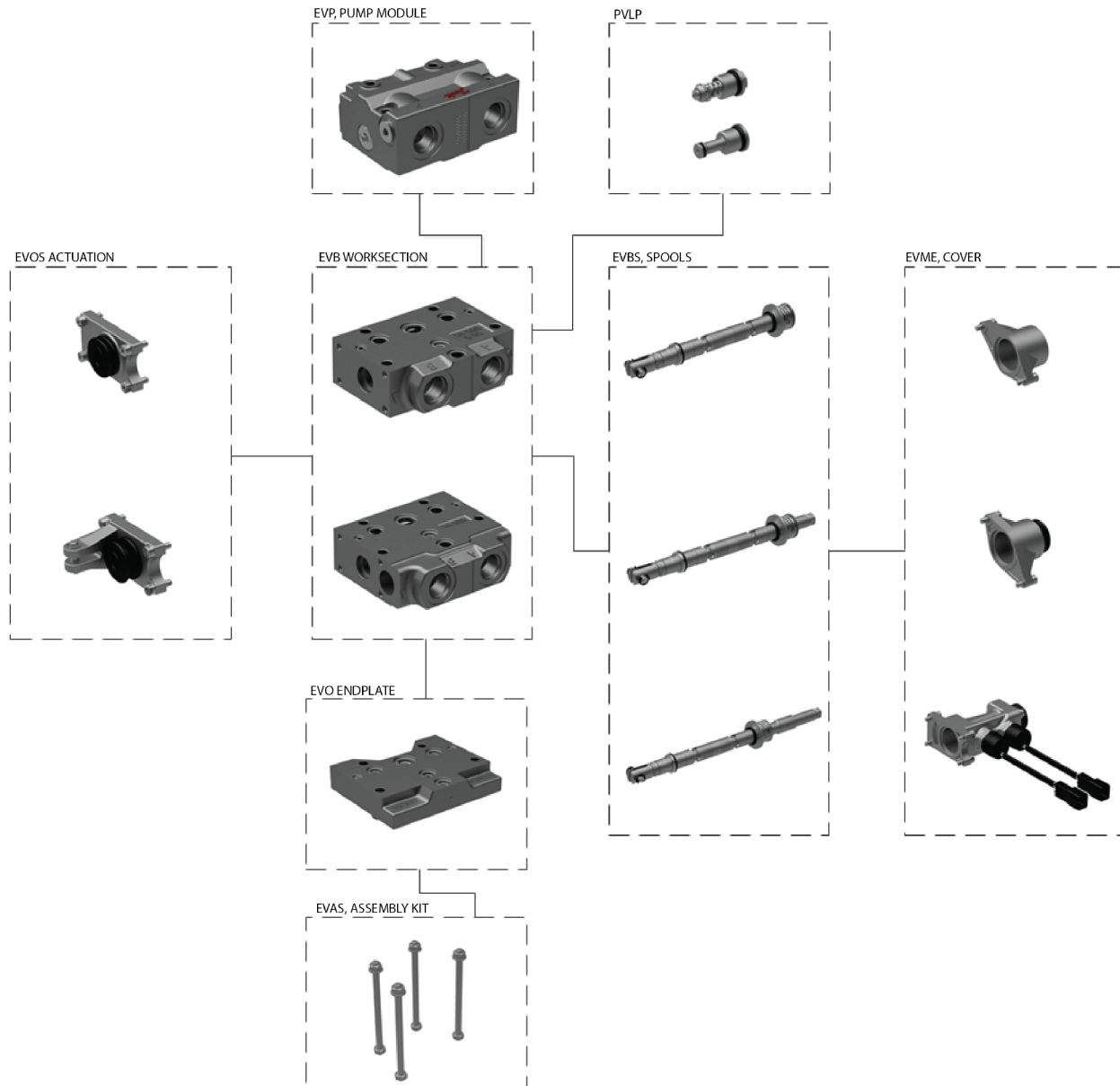

F101 942

LCO 60 Directional Control Valve

Module selection chart

EVP, pump side modules, mechanical acting

Symbol	Description	Code number
<p>P109139</p>	Open center pump side module for pumps with fixed displacement. For mechanical actuated valve groups.	P = G1/2, T = G 1/2 11173005
		P = SAE#10, T = SAE#10 11172981
<p>P109138</p>	Closed center pump side module for pumps with variable displacement. For mechanical actuated valve groups.	P = G1/2, T = G 1/2 11173006
		P = SAE#10, T = SAE#10 11173002

Connections:

P,T = G 1/2 - 14 in / LS, M = G 1/4 - 19 in

P,T = 7/8 - 14 unf; / LS, M = 9/16 - 18 unf

EVB, basic modules, mechanical acting

Symbol	Description	Code number
<p>P109108</p>	Low Body with Load drop check valve. For mechanical actuated valve groups.	G1/2 11168505
		SAE#10 11168504
<p>P109109</p>	Medium Body with Load drop check valve and Facilities for shock valves A/B. For mechanical actuated valve groups.	G1/2 11168503
		SAE#10 11168502

Connections:

A/B = G 1/2 - 14 in, 14 mm deep

A/B = 7/8 - 14 unf, 1/2 in deep

ECC 80 Directional control valve

Module selection chart

PVLA, suction valve (fitted in EVB), Mechanical and Electrical acting

Symbol	Description	Code number
<p>P109110</p>	Suction valve for port A and/or B.	157B2001
	*Cavity Plug valve for port A and/or B.	11177714

* Block connection between port and tank when is not necessary auxiliary valves

PVLP, shock and suction valve (fitted in EVB), Mechanical and Electrical acting

Code no. 157B....	2032	2050	2063	2080	2100	2125	2140	2150	2160	2175	
Settings	bar	32	50	63	80	100	125	140	150	160	175
	[psi]	[460]	[725]	[914]	[1160]	[1450]	[1813]	[2031]	[2175]	[2320]	[2538]

Code no. 157B....	2190	2210	2230	2240	2250	2265	2280	2300	2320	
Settings	bar	190	210	230	240	250	265	280	300	320
	[psi]	[2755]	[3045]	[3335]	[3480]	[3625]	[3845]	[4061]	[4351]	[4641]

PVLP, shock and suction valve, Mechanical and Electrical acting

Symbol	Description
<p>P109111</p>	Shock and suction valve for port A and/or B. (Not adjustable). Lifetime 200.000 actuations.

PVLP, shock and suction valve adjustable (fitted in EVB), Mechanical acting

Setting range	Code number
121-250 bar	11006594
251-285 bar	11006595

Symbol	Description
<p>T T1 P Pp LS</p>	Shock and suction valve for port A and/or B just for mechanical acting open spool style. (adjustable). Lifetime 200.000 actuations.

ECO 60 Directional Control Valve

Module selection chart

EVOS, open spool mechanical actuation, Mechanical acting

Description	Code number
EVOS, Mechanical Standard, spring centered. Without actuation lever and base.	047768
EVOS, Mechanical Standard, spring centered. With actuation lever and base.	11175314
EVOS, Through acting, spring centered.	11172533

EVOS, accessory, Mechanical acting

Description	Code number
Accessories - Base handle black	11170923

EVBS, Mechanical flow control spools, Female Extension

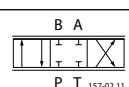
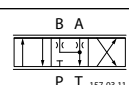
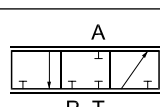
Symbol	Code number					
	Spool size, flow range l/min					
	A	B	C	D	E	F
	8	25	40	60	80	100
 4-way, 3-position Closed neutral position	11169728	11169733	11169737	11169741	11169745	11182571
 4-way, 3-position Throttled, open neutral position	11169725	11169730	11169735	11169739	11169743	11182572
 3-way, 3-position Closed neutral position	11169729	11169734	11169738	11169742	11169746	Not available

EVBS, Mechanical flow control spools, Female Extension and through acting

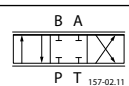
Symbol	Code number					
	Spool size, flow range l/min					
	A	B	C	D	E	F
	8	25	40	60	80	100
 4-way, 3-position Closed neutral position	11170744	11170747	11170750	11170753	11170756	11187072



ECO 80 Directional control valve

Module selection chart

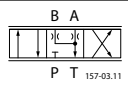
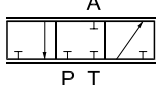
Symbol	Code number					
	Spool size, flow range l/min					
 4-way, 3-position Throttled, open neutral position	11170743	11170746	11170749	11170752	11170755	11187061
 3-way, 3-position Closed neutral position	11170745	11170748	11170751	11170754	11170757	Not available

EVBS, Mechanical flow control spools

EVBS, Mechanical flow control spools, Female Extension and Detent 03 position and 02 position spool out*

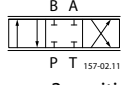
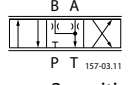
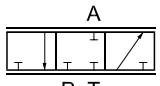
Symbol	Code number					
	Spool size, flow range l/min					
	A	B	C	D	E	F
	8	25	40	60	80	100
 4-way, 3-position Closed neutral position	11170627	11170634	11170638	11170642	11170646	11182609
 4-way, 3-position Throttled, open neutral position	11170625	11170632	11170636	11170640	11170644	11182610
 3-way, 3-position Closed neutral position	11170631	11170635	11170639	11170643	11170647	Not available

* For 02 position detent spool out is necessary to use an accessory part number 11173406, see [EVME, detent 02 position spool to A or B](#) on page 14.

ECO 60 Directional Control Valve

Module selection chart

EVBS, Mechanical flow control spools, Female Extension and Micro Switch

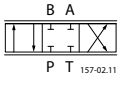
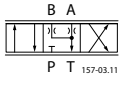
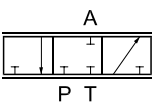
Symbol	Code number					
	Spool size, flow range l/min					
	A	B	C	D	E	F
	8	25	40	60	80	100
 4-way, 3-position Closed neutral position	11170264	11170268	11170272	11170276	11170280	11187073
 4-way, 3-position Throttled, open neutral position	11170262	11170266	11170270	11170274	11170278	11187074
 3-way, 3-position Closed neutral position	11170265	11170269	11170273	11170277	11170281	Not available

EVME, OPEN SPOOL CENTERING, Mechanical acting

Description	Code number
EVME, spring centering, detent 03	11169579
EVME, spring centering, 02 positions	11169579 + accessory 11173406
EVME, Through acting	11169580

EVME, Micro Switch, Mechanical acting

Description	Code number
EVME, Micro Switch NO	11170841

EVO, end plate, Mechanical and Electrical acting

Symbol	Description	Code number
 P109140	EVO without active elements. No connections.	11172381

EVO, end plate with Lx, Mechanical and Electrical acting

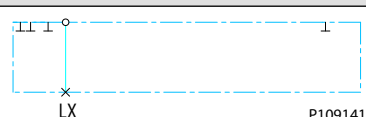
Symbol	Description	Threads	Code number
 P109141	EVO without active elements. Lx connections	G ¼ - 19 in	11172379
		9/16 - 18 unf	11172380



EVO 60 Directional Control valve

Module selection chart

EVT, assembly kit, Mechanical and Electrical acting

PVB's	1	2	3	4	5	6	7	8	9	10	11	12
Code n	11173102	11173103	11173104	11173105	11173106	11173107	11173108	11173109	11173110	11173111	11173112	11173113

Electrical Module selection chart

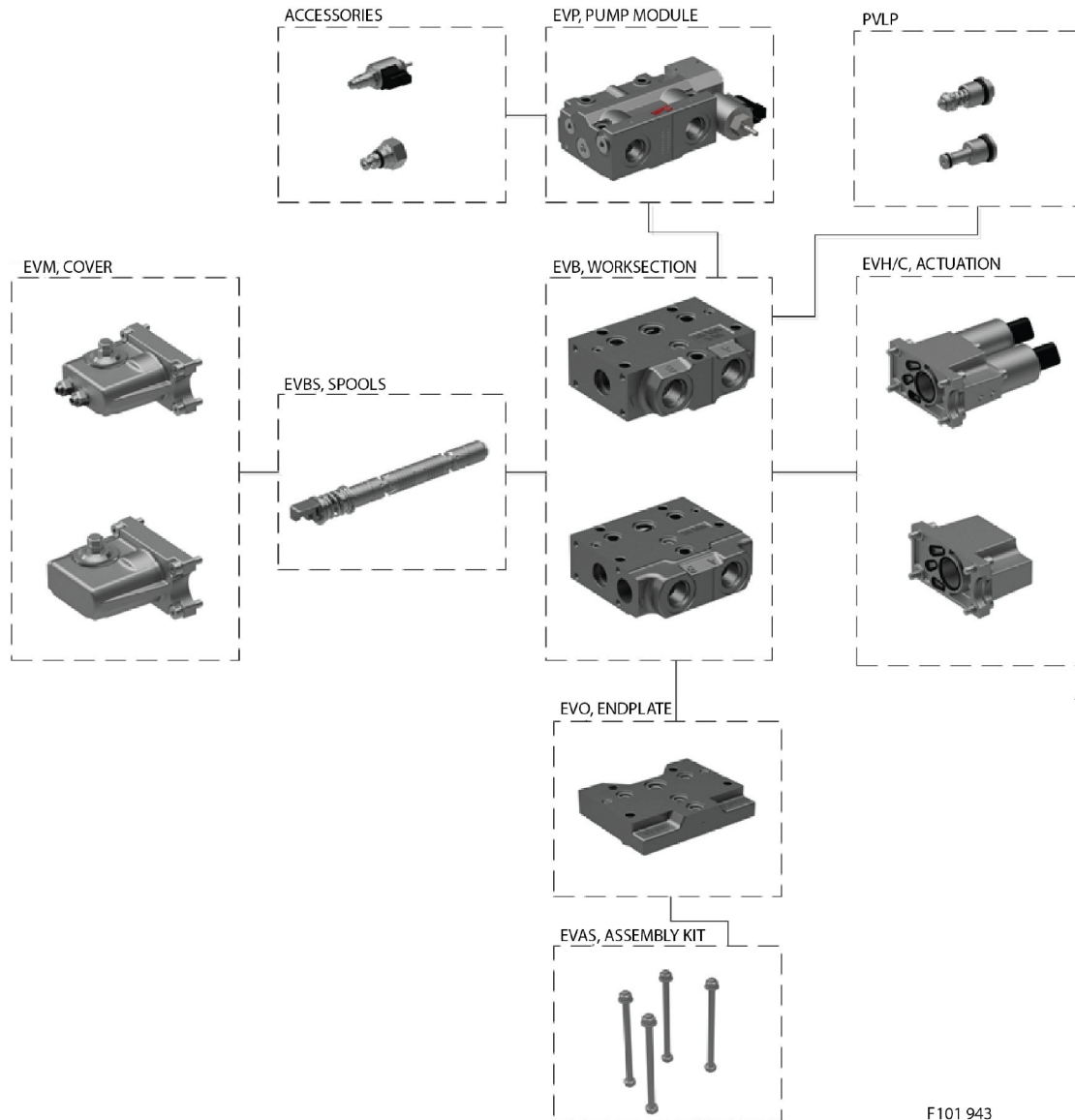

ECO 80 Directional Control Valve

Module selection chart

Electrical Module selection chart, symbols, description and code numbers

EVP, pump side modules, Electrical acting

Symbol	Description		Code number
<p>P109112</p>	Open center pump side module for pumps with fixed displacement. With pilot oil supply for electrically actuated Valves.	P = G1/2, T = G 1/2	11172996
		P = SAE#10, T = SAE#10	11173010
<p>P109112</p>	Closed center pump side module for pumps with variable displacement. With pilot oil supply for electrically actuated Valves.	P = G1/2, T = G 1/2	11172997
		P = SAE#10, T = SAE#10	11173011
<p>P109113</p>	Open center pump side module for pumps with fixed displacement. With pilot oil supply for electrically actuated Valves. Connection for electrical LS unloading valve, PVPX (not incl.)	P = G1/2, T = G 1/2	11173023
		P = SAE#10, T = SAE#10	11173000

Connections: P,T = G ½ - 14 in / LS, M = G ¼ - 19 in
 P,T = 7/8 - 14 unf; / LS, M = 9/16 - 18 unf

EVPX, electrical LS unloading valve

Description		Code number
PVPX, Normally open: LS pressure relieved with no signal to PVPX	12V	11172430
	24V	11172429

ECO 80, plug for external pilot oil supply

Description	Threads	Code number
Plug for external pilot oil supply	G ¼ - 19 in	11177014
	9/16 - 18 unf	11177013



ECO 60 Directional Control valve

Module selection chart

EVB, basic modules, Electrical acting

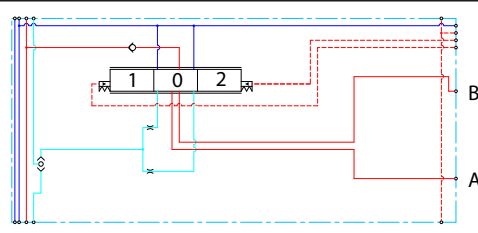
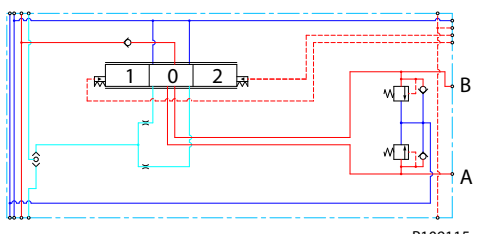
Symbol	Description		Code number
 <p>P109114</p>	Low Body with Load drop check valve. For electrical actuated valve groups	G1/2	11168506
		SAE#10	11168507
 <p>P109115</p>	Medium Body with Load drop check valve and Facilities for shock valves A/B. For electrical actuated valve groups	G1/2	11168509
		SAE#10	11168508

Connections:

A/B = G ½ - 14 in, 14 mm deep

A/B = 7/8 - 14 unf, ½ in deep

LCO 60 Directional Control Valve

Module selection chart

EVM, mechanical actuation

Description	Code number
EVM, Standard, spring centered. Without actuation lever and base.	11119157
EVM, Standard, spring centered. With actuation lever and base.	11167001
EVM, spring centered, Individual oil flow adjustment to ports A and B. Without actuation lever and base.	11145204
EVM, spring centered, Individual oil flow adjustment to ports A and B. With actuation lever and base.	11167002

EVM, accessory

Description	Code number
Accessories - Base handle black	11107587

EVC, cover for mechanical actuation, assembled on side "A"

Description	Code number
EVC, Cover for purely mechanically operated valve with EVM style	11171318

EVHC, electrical actuation, assembled on side "A"

Description	Code number
EVHC, DEUTSCH Connector. 12 V	11162297
EVHC, DEUTSCH Connector. 24 V	11162298

EVHCO, On/Off electrical actuation, assembled on side "A"

Description	Code number
EVHCO, DEUTSCH Connector 12 V	11179573
EVHCO, DEUTSCH Connector 24 V	11179572

EVH, hydraulic actuation, assembled on side "A"

Symbol	Description	Code number
	EVH, Cover for Hydraulic actuation. EVH 9/16-18 UNF	11169487
	EVH, Cover for Hydraulic actuation. EVH G1/4	11169486

EVBS, Electrical flow control spools

Symbol	Code number					
	Spool size, flow range l/min					
	A	B	C	D	E	F*
		8	25	40	60	80

EVO 60 Directional control valve

Module selection chart

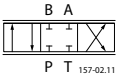
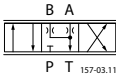
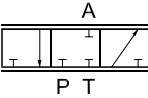
Symbol	Code number					
	Spool size, flow range l/min					
 <p>4-way, 3-position Closed neutral position</p>	11170445	11170449	11170453	11170457	11170461	11182178
 <p>4-way, 3-position Throttled, open neutral position</p>	11170443	11170447	11170451	11170455	11170459	11182177
 <p>3-way, 3-position Closed neutral position, P -> A</p>	1117044	11170450	11170454	11170458	11170462	Not available

* Only to be used as on/off spool.

EVO, end plate, Mechanical and Electrical actingSee [EVO, end plate, Mechanical and Electrical acting](#) on page 33**EVO, end plate with Lx, Mechanical and Electrical acting**See [EVO, end plate with Lx, Mechanical and Electrical acting](#) on page 33**EVT, assembly kit, Mechanical and Electrical acting**See [EVT, assembly kit, Mechanical and Electrical acting](#) on page 34

ECO 80 Directional Control Valve

Dimensions

ECO 80

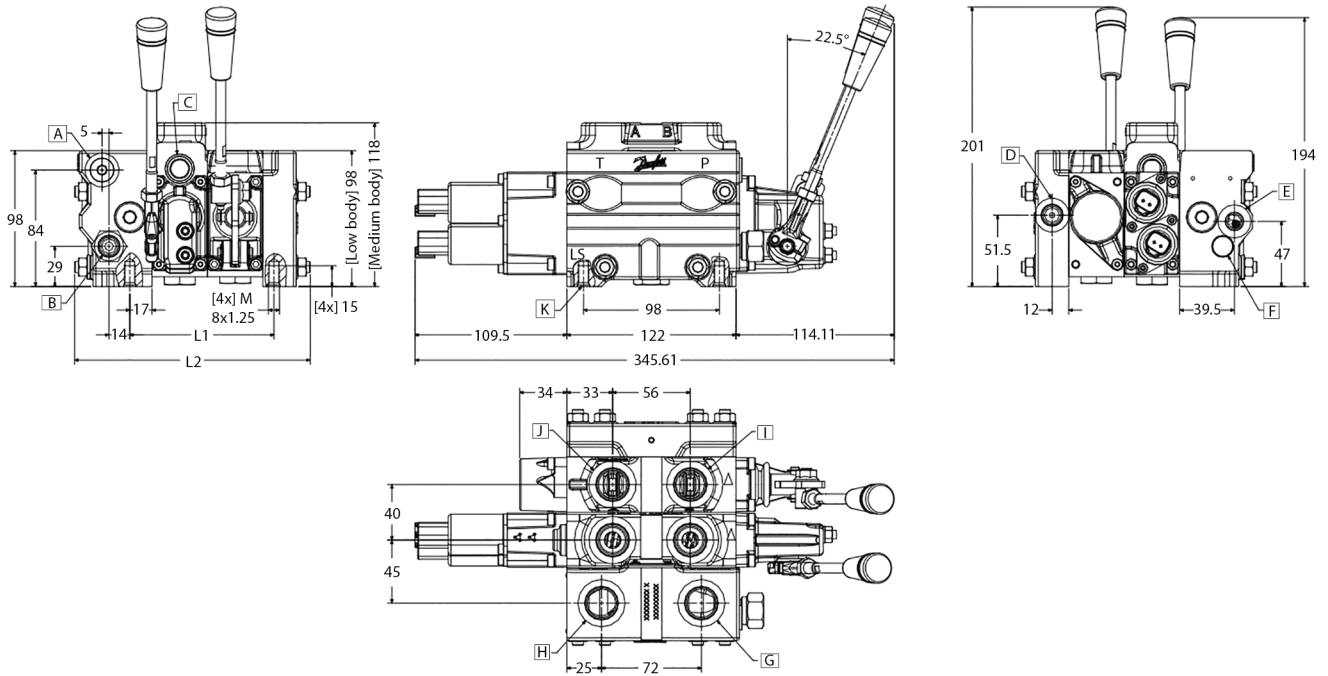

- A:** Pressure gauge connection
- B:** Pilot pressure connection
- C:** Shock and suction valve, PVLP and PVLA
- D:** Lx connection
- E:** LS connection
- F:** LS pressure relief valve
- G:** Pump connection
- H:** Tank connection
- I:** Work port B
- J:** Work port A
- K:** Fixing holes

EVb		1	2	3	4	5	6	7	8	9	10
L ₁	mm	65	105	145	185	225	265	305	345	385	425
L ₂	mm	130	170	210	250	290	330	370	410	450	490



ECO 80 Directional Control Valve

Dimensions

EVM and EVOS Lever positions

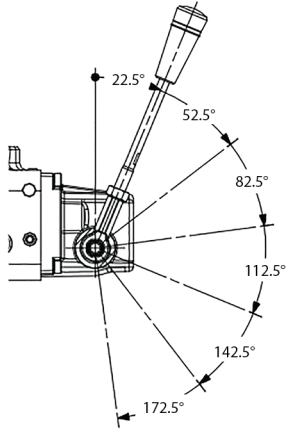

Base with an angle of 22.5°

Base with an angle of 22.5°

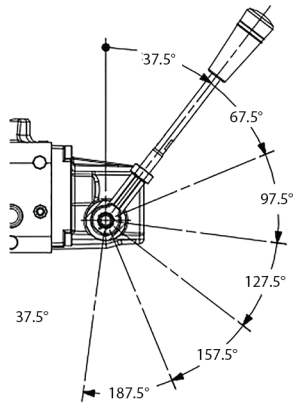
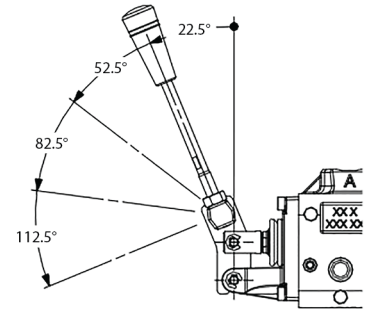

Base with an angle of 37.5°

Base with an angle of 157.5°

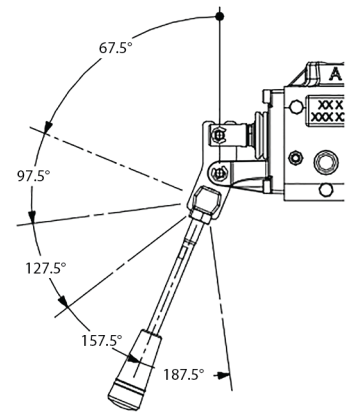

ECO 80 Directional Control Valve

Other operating conditions

Particle content, degree of contamination

Biodegradable oils

ECO 80 valves can be used in systems with rapeseed oil. The use of rapeseed oil is conditioned by:

- complying with the demands on viscosity, water content, temperature and filtering etc. (see chapters below and technical data).
- adapting the operating conditions to the directions of the oil supplier.

Before using other biodegradable fluids, please consult the Danfoss organization. Oil filtration must prevent particle content from exceeding an acceptable level, i.e., an acceptable degree of contamination.

Maximum contamination for ECO 80 is 23/19/16 (see ISO 4406. Calibration in accordance with the ACFTD method). In our experience, a degree of contamination of 23/19/16 can be maintained by using a filter fineness as described in the next section. For more information, please see the Danfoss literature:

- *Design Guidelines for Hydraulic Fluid Cleanliness Technical Information, 520L0467.*
- *Hydraulic Fluids and Lubricants Technical Information, 521L0463.*
- *Experience with Biodegradable Hydraulic Fluids Technical Information, 521L0465.*

Filtration

Effective filtration is the most important precondition in ensuring that a hydraulic system performs reliably and has a long working life. Filter manufacturers issue instructions and recommendations. It is advisable to follow them.

System filters

Where demands on safety and reliability are very high a pressure filter with bypass and indicator is recommended. Experience shows that a 10 µm nominal filter (or finer), or a 20 µm absolute filter (or finer) is suitable. It is our experience that a return filter is adequate in a purely mechanically operated valve system.

The fineness of a pressure filter must be selected as described by the filter manufacturer so that a particle level of 23/19/16 is not exceeded.

The filter must be fitted with pressure gauge or dirt indicator to make it possible to check the condition of the filter.

In systems with differential cylinders or accumulators the return filter must be sized to suit the max. return oil flow. Pressure filters must be fitted to suit max. pump oil flow.



www.khadamathydraulic.com

Tell: 021-55882749

Tell: 021-33488178

Fax: 021-33488105



LCO 60 Directional Control Valve



www.khadamathydraulic.com

Tell: 021-55882749

Tell: 021-33488178

Fax: 021-33488105



LC0 60 Directional control valve

Products we offer:

- Bent Axis Motors
- Closed Circuit Axial Piston Pumps and Motors
- Displays
- Electrohydraulic Power Steering
- Electrohydraulics
- Hydraulic Power Steering
- Integrated Systems
- Joysticks and Control Handles
- Microcontrollers and Software
- Open Circuit Axial Piston Pumps
- Orbital Motors
- PLUS+1® GUIDE
- Proportional Valves
- Sensors
- Steering
- Transit Mixer Drives

Danfoss Power Solutions is a global manufacturer and supplier of high-quality hydraulic and electronic components. We specialize in providing state-of-the-art technology and solutions that excel in the harsh operating conditions of the mobile off-highway market. Building on our extensive applications expertise, we work closely with our customers to ensure exceptional performance for a broad range of off-highway vehicles.

We help OEMs around the world speed up system development, reduce costs and bring vehicles to market faster.

Danfoss – Your Strongest Partner in Mobile Hydraulics.

Go to www.powersolutions.danfoss.com for further product information.

Wherever off-highway vehicles are at work, so is Danfoss. We offer expert worldwide support for our customers, ensuring the best possible solutions for outstanding performance. And with an extensive network of Global Service Partners, we also provide comprehensive global service for all of our components.

Please contact the Danfoss Power Solution representative nearest you.

Comatrol

www.comatrol.com

Schwarzmueller-Inverter

www.schwarzmueller-inverter.com

Turolla

www.turollaocg.com

Hydro-Gear

www.hydro-gear.com

Daikin-Sauer-Danfoss

www.daikin-sauer-danfoss.com

Local address:

Danfoss Power Solutions (US) Company
2800 East 13th Street
Ames, IA 50010, USA
Phone: +1 515 239 6000

Danfoss Power Solutions GmbH & Co. OHG
Krokamp 35
D-24539 Neumünster, Germany
Phone: +49 4321 871 0

Danfoss Power Solutions ApS
Nordborgvej 81
DK-6430 Nordborg, Denmark
Phone: +45 7488 2222

Danfoss Power Solutions Trading (Shanghai) Co., Ltd.
Building #22, No. 1000 Jin Hai Rd
Jin Qiao, Pudong New District
Shanghai, China 201206
Phone: +86 21 3418 5200

Danfoss can accept no responsibility for possible errors in catalogues, brochures and other printed material. Danfoss reserves the right to alter its products without notice. This also applies to products already on order provided that such alterations can be made without changes being necessary in specifications already agreed. All trademarks in this material are property of the respective companies. Danfoss and the Danfoss logotype are trademarks of Danfoss A/S. All rights reserved.