

Vane Technology

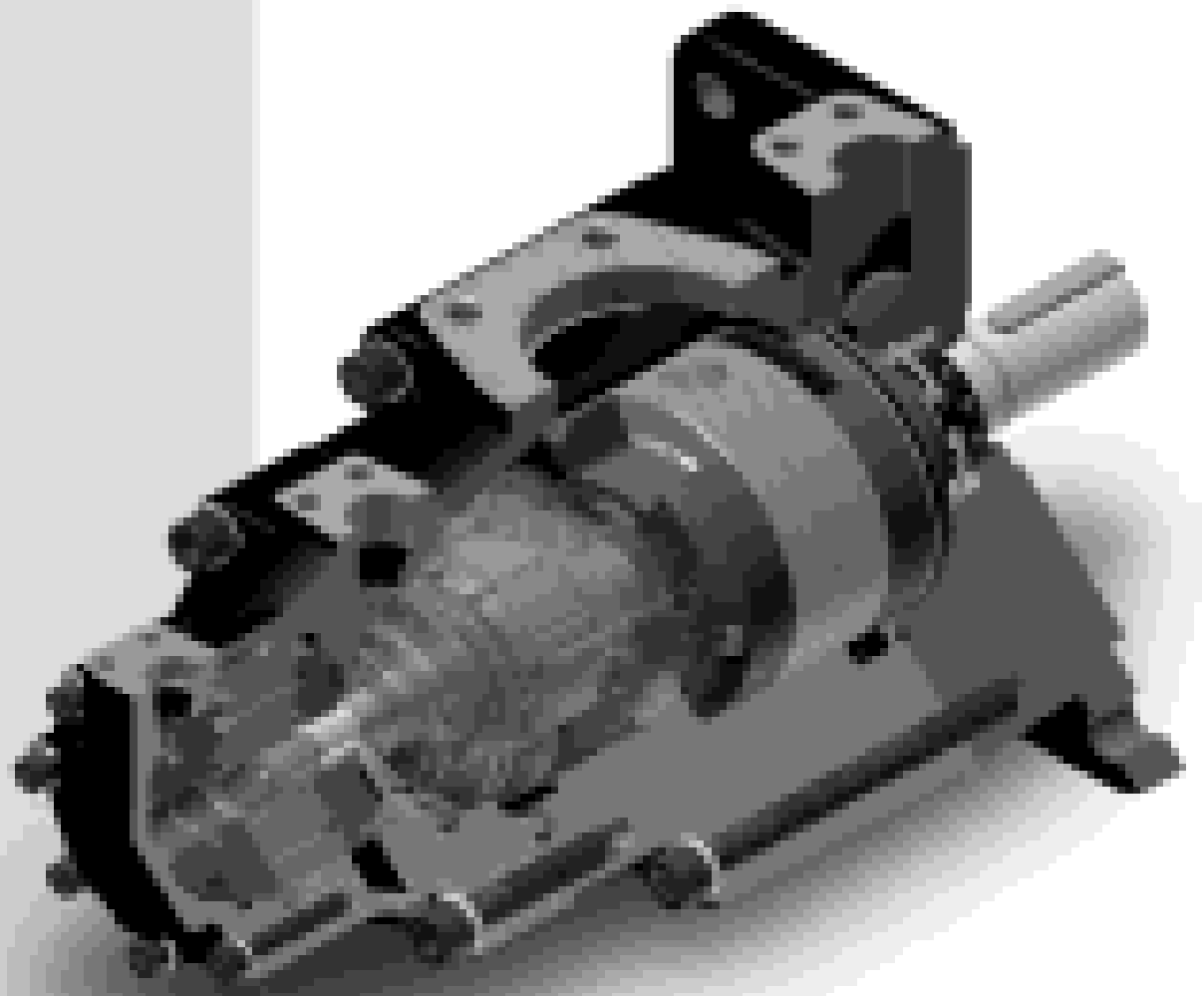

T D Z

Vane Pumps & Motors



- Vane pumps
- Vane motors
- Steering pumps
- Use & Maintenance manual

TDZ Hydraulics introduce the most complete line of fixed displacement vane pumps, both for mobile and industrial applications. Hydraulically balanced, our pumps offer low noise level and high volumetric efficiency.

Flows: single pumps: 2 cm³ up to 270 cm³, (0,6 up to 85 gallons).
double pumps: 10+10 cm³ up to 270+190 cm³, (6+1 up to 85+61 gallons).
Triple pumps: 48+10+10 cm³ to 270+191+100 cm³, (14+3+3 gal. up to 85+61+30 gal.)

Maximum pressure: 210 bar, (3.000 p.s.i.), in VK, VS, VQ series
280 bar, (4.000 p.s.i.) in DT6 series.

ENGLISH

TDZ Hydraulics stellt das vollständigste Programm von Flügelzellenpumpen mit festem Schluckvolumen für industrielle und mobile Anwendungen zur Verfügung, hydraulisch ausgeglichen bieten sie niedrige Geräuschpegel, sowie einen sehr hohen volumetrischen Wirkungsgrad.

Schluckvolumen: Einzelpumpe von 2 cm³ bis 270 cm³, (von 0,6 bis 85 Gallonen).
Doppelpumpe von 10+10 cm³ bis 270+190 cm³, (6+1 up to 85+61 Gallonen).
Dreifachpumpe von 48+10+10 cm³ bis 270+191+100 cm³, (von 14+3+3 gal. bis 85+61+30gal.)

Höchstdruck: 210 bar, (3.000 p.s.i.), für VK, VS, VQ Typen
280 bar, (4.000 p.s.i.) für die DT6 Typen.

DEUTSCHE

La TDZ Hydraulics presenta la piú completa serie di pompe a palette a portata fissa sia per applicazioni su macchinario mobile che industriale. Bilanciate idraulicamente, le nostre pompe garantiscono un basso livello sonoro ed un alto rendimento volumetrico.

Portata: pompe singole da 2 cm³ a 270 cm³, (da 0,6 a 85 gallons).
pompe doppie da 10+10 cm³ a 270+190 cm³, (da 6+1 a 85+61 gallons).
pompe triple da 48+10+10 cm³ a 270+191+100 cm³, (da 14+3+3 gal. a 85+61+30 gal.)

Pressione massima: 210 bar, (3.000 p.s.i.), per la serie VK, VS, VQ
280 bar, (4.000 p.s.i.) per la serie DT6.

ITALIANO

TDZ Hydraulics présente la gamme la plus complète de pompes à palettes à cylindrée fixe, tant sur applications mobiles qu'industrielles. Hydrauliquement équilibrées, nos pompes sont silencieuses et offrent un rendement volumétrique élevé.

Débits: Pompes simples de 2 cm³/tr à 270 cm³/tr, (de 0,6 à 85 galons).
Pompes doubles de 10+10 cm³ à 270+190 cm³/tr, (de 6+1 à 85+61 galons).
Pompes triples de 48+10+10 cm³ à 270+191+100 cm³, (de 14+3+3 gal. á 85+61+30 gal.)

Pression maximale: 210 bar, (3.000 p.s.i.), pour les séries VK, VS, VQ - 280 bar, (4.000 p.s.i.) pour la serie DT6.

FRANÇAIS

TDZ Hydraulics presenta la más completa serie de bombas de paletas de caudal fijo, tanto para aplicaciones móviles como industriales. Con un diseño equilibrado hidráulicamente, nuestras bombas ofrecen un bajo nivel sonoro y un alto rendimiento volumétrico.

Caudales: Bombas simples de 2 cm³ hasta 270 cm³, (de 0,6 hasta 85 galones).
Bombas dobles de 10+10 cm³ hasta 270+190 cm³, (de 6+1 hasta 85+61 galones).
Bombas triples de 48+10+10 cm³ hasta 270+191+100 cm³ (de 14+3+3 hasta 85+61+30gal.)
Presiones máximas: 210 bar, (3.000 p.s.i.), en las series VK, VS, VQ - 280 bar, (4.000 p.s.i.) en la serie DT6.

ESPAÑOL

DISTRIBUTED BY:

DATA SHEET

Introduction

General Information BH* & V*
General Information DT6*

5

Single Vane Pumps

BH*, V* and DT6* single vane pumps

13

Thru Drive Single Vane Pumps

V**T thru drive single vane pumps

49

Double Vane Pumps

V* and DT6* double vane pumps

57

Triple Vane Pumps

DT6* triple vane pumps

79

Single and Double Vane Pumps 4 holes ISO Flange

T6GC and T6GCC for direct mounting in Power Take Off

87

Single Vane Pumps With Flow Control and Priority Valve. Power Steering Vane Pumps

95

Vane Motors

MD4C & MH4D Motors

105

USE, MAINTENANCE AND REPAIR GUIDE

Description and Maintenance

115

Troubleshooting

123

Real Images of Common Failures

133

Pump start-up. Identification. Assembly & Disassembly. Change of Ports Combination
Change of cartridge rotation

141





Vane Pumps & Vane motors



BH*, V* & DT6 HYDRAULIC VANE PUMPS

INTRODUCTION

TDZ vane pumps are manufactured in a wide range of displacements, from 2cc/r to 269cc/rev. for single pumps, 460cc/rev. for double pumps and 560cc/rev. for triple pumps.

All **TDZ** pumps have a low power to weight ratio, high efficiency, low noise levels, optional inlet and outlet port positions and ease of maintenance.

Ease of maintenance is achieved by the pump design, where the working components are contained within a cartridge which can quickly and easily be replaced without disconnecting the pump from the prime mover or moving it away from the pipe work. **TDZ** vane pumps are hydraulically balanced, reducing wear and eliminating bearing loads from within the pump.

The option to rotate the outlet port 90 degrees in relation to the inlet port provides flexibility and easy installation.

Depending on the application, there are three versions of the larger single, double and triple vane pumps: low noise industrial models VS and BHS, mobile models VQ and BHQ and multi-purpose models DT6(275bar).

Models VS, VQ and DT6 have UNC threads for the port flanges whilst models BHS, BHQ have metric threads. On single pumps the outlet port is at the shaft end for models VS, VQ, DT6 on models BHS BHQ the outlet port is at the cover end.



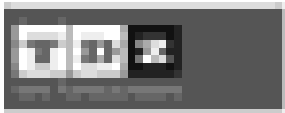

V* & BH* HYDRAULIC VANE PUMPS

INTRODUCTION

PUMP DRIVE

Direct coaxial drive is recommended via flexible coupling. For indirect drives imposing a radial load on the shaft, consult **TDZ** or your nearest distributor for advice.

ROTATION

The direction of rotation can be reversed by turning the ring, rotor and vanes through 180degrees. Direction of rotation is viewed from the shaft end.

STARTING

TDZ vane pumps are self priming, however, if possible, fill the pump with oil before starting or bleed the outlet port while the pump is running to remove any trapped air.

FILTRATION

For satisfactory service life, full flow filtration to provide fluid cleanliness conforming to ISO code 18/15 or better is recommended.

HYDRAULIC FLUIDS

Use antiwear industrial hydraulic oils with a viscosity of 25 - 49 cST. Automotive crankcase oils SAE10-SAE20 may also be used depending on the operating temperature.

The optimum operating temperature is 50°C with a maximum of 70°C. At higher temperatures service life is decreased with degradation of the wearing parts and seals.

For fire resistance fluids, the "F3" version with special seals must be used at reduced pressures and speeds as indicated below.

MAXIMUM SPEED RANGES

With antiwear fluids: 1800 to 2500 rpm (depending on model type. See performance chart).

With synthetic fluids, water glycols and water in oil emulsions, the maximum recommended speed is 1200 rpm. A special version of the BHP2 pump is available for speeds up to 5000 rpm.

Speeds shown are given as a guide only based on the correct fluid and correct suction characteristics as recommended by our Technical Services department.

Long or restricted suction lines can cause cavitation, therefore the maximum running speed must be reduced. Avoid using 90 degree elbows in suction lines, use swept bends where possible. Too viscous fluids will also cause cavitation.

When using lower displacement pumps within a given pump frame size, speeds slightly higher than those shown in the charts area acceptable.

For antiwear hydraulic fluids and water glycols, the inlet pressure must not exceed 0.2 bar vacuum, for synthetic fluids and water in oil emulsions, the inlet pressure must not exceed 0.1 bar vacuum.

MINIMUM SPEED: 600 rpm

This data is for V*20, V*25, V*35, V*45, BH*4, BH*6, BH*7, double and triple pumps. For other pumps see chart.

The intermittent pressures shown in the table can be maintained for 10% of the time, with a maximum duration of 6 seconds/minute.





V* & BH* HYDRAULIC VANE PUMPS

INTRODUCTION

MAXIMUM CONSTANT PRESSURE

Anti-wear Hydraulic Oil: **from 175 to 210 Bar**

Synthetic Oil: **from 175 to 210 Bar**

Water-Glycol emulsions: **160 Bar**

Water-in-oil emulsions: **70 Bar**

SOUND LEVEL

Single Pumps:

VS25 and BHS4: 62 dB (A)

VS35 and BHS6: 65 dB (A)

VS45 and BHS7: 71 dB (A)

Double Pumps:

VS43: 68 dB (A)

VS63: 69 dB (A)

VS73: 71 dB (A)

VS64: 69 dB (A)

VS74: 71 dB (A)

VS76: 72 dB (A)

Sound levels measured with hydraulic oil at 140 Bar, 1500 rpm and a vacuum at pump inlet of 0,17 Bar.

ADMISSIBLE TORQUES FOR THE SHAFTS

All the shafts available for our single and motors are sufficient for working at the maximum pressure specified for each model.

However, in the case of double pumps and thru drive pumps, if both cartridges/pumps work simultaneously under pressure, the sum of the torques absorbed for each of them may exceed the resistance of the shaft.

In practice, the absorbed torque for each cartridge/pump may be calculated with the formula:

$$T = \frac{P \times V}{59}$$

Where: T = Torque in Nm.
P = Working pressure in Bars.
V = Cubage in cm³/rev. or flow in lts/min at 1.000 r.p.m.

In order to choose the most appropriate type of shaft, calculate said torque sum under the most unfavourable working conditions and compare them with the torque values admitted for each shaft as indicated in table 1.

Analogically, in the thru drive pumps, the absorbed torque for the second pump will be calculated under the most unfavourable conditions, and it must be checked that it does not exceed the torque values admissible as indicated in table 2 for each connection.

Table 1

| Pump Type | Shaft n° | Max. Torque Nm |
|-----------|----------|----------------|
| V*42 | 1 | 313 |
| V*43 | 11 | 313 |
| V*4T | 86 | 392 |
| V*63 | 1 | 392 |
| V*64 | 11 | 568 |
| V*6T | 86 | 588 |
| V*73 | 1 | 588 |
| V*74 | 11 | 803 |
| V*76 | 11 | 803 |
| V*7T | 86 | 803 |

Table 2

| Rear Flange (Conection) | Max. Torque Nm |
|-------------------------|----------------------------|
| A | 130 |
| B | 315 |
| C | 440 (V*6TC) 700 (V*7TC) |



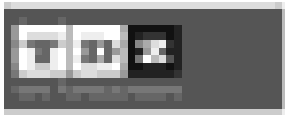

DT6 HYDRAULIC VANE PUMPS

INTRODUCTION

DT series vane pumps are fixed displacement and high efficiency pumps. Designed under SAE J744c 2 bolt standards, (excluding T6EDC triple pumps), the complete range includes single, double and triple units with wide possibilities of flow combinations, porting configurations, possibilities of use of fluids other than petroleum-based oil and a vast number of different shafts.

The **DT series** is a hydraulically-balanced design. Quality and composition of materials have been checked and tested over millions of cycles on our experimental test benches. This fact, together with a rigid bearing and a high resistance to particle contamination thanks to the double lip vane, makes DT series pumps long-life hydraulic units.

Within 3 different cartridge kit sizes, flows available range from 3 to 31GPM in C size, 14 to 61GPM in D size and 42 to 85 GPM in E size. As in our earlier BH* and V* vane pump series, cartridge kit design allows easy service when replacement or conversion is needed, reducing the operation to just a few minutes. Cartridge kit design also offer possibilities of quick change of rotation by changing the position of cam ring.

Four different combinations of porting positions are possible in single pumps. In double pumps 32 combinations are possible and 128 for triple pumps.

The high pressure capability of 275 bar in the **DT6 series** reduces installation costs and provides long life at reduced pressure. The high mechanical and volumetric efficiency reduces heat generation and energy consumption. Lower noise levels than most of hydraulic pump designs suppose an advantage and safety for machine operators.

TDZ Hydraulics DT series vane pumps are unidirectional but they have been designed for an easy change of rotation. Instructions for change of rotation are included in this catalogue (Instructions for Use and Repair).

RECOMMENDED FLUIDS

Operating characteristics showed in this catalogue have been calculated considering the use of Antiwear petroleum base fluids.

Non Antiwear Petroleum Base Fluids, Synthetic Fluids, Water In Oil Emulsions or Water Glycols are also acceptable. In these cases, speed and pressure limits will be supplied directly by **TDZ** Hydraulics or your nearest distributor.

VISCOSITY

Optimum viscosity for maximum life is between 30 and 40cSt.

Maximum viscosity is 2000 cSt at very low speed and pressure and 110 cSt at full speed and pressure.

Minimum viscosity is 10cSt,(18 cSt for fluids other than Antiwear Petroleum Base fluids).

FLUID CONTAMINATION AND FILTRATION

Fluid must be clean during the entire working life of the pump in order to maintain a contamination level of ISO 18/14 or even better, if possible.

Filters with 25 microns are adequate but will not guarantee total cleanliness levels. Suction strainers should be of an adequate size to provide the recommended inlet pressure. For cold starts or fire-resistant fluids, oversize strainers must be used or omitted.

Higher levels of water than 0.10% in mineral oils or 0.05% in synthetic or biodegradable fluids are not acceptable. In these cases, water should be drained off the circuit.

FLUID TEMPERATURES

Fluid viscosity should be selected depending on the normal operating temperature of the unit. Cold starts pump should operate at low pressure and, if possible, low speeds until the fluid warms up to a convenient viscosity for full power application.

MINIMUM AND MAXIMUM SPEED

Minimum: 400rpm.

Maximum: 2800 rpm in C series, 2500 rpm in D series and 2200 in E series.

Higher flows of C and D sizes also involves speed limitations, as indicated in the technical chart of this catalogue. Fluids other than Antiwear Petroleum Base fluids will also involve a speed limit, depending on the choice, (consult **TDZ** or your nearest distributor).





DT6 HYDRAULIC VANE PUMPS

INTRODUCTION

PRESSURE RATINGS

Maximum pressure in **DT6 vane pumps** is 275 bar intermittent for C series and 240 bar for D and E series. Nevertheless, exceptions are indicated in this catalogue when fluids other than Antiwear Petroleum Base are used or in the case of use of high flows of C and D pump sizes.

Both continuous and intermittent pressures are indicated in this catalogue. The maximum period of intermittent pressure may be considered acceptable when the average pressure time is less than or equal to the continuous recommended pressure, for that particular model during a complete cycle of work.

MINIMUM INLET PRESSURE

Minimum allowable inlet pressure is 0.95 bar for 1,800 rpm or less, 1.10 bar between 1,800 and 2,300 rpm and 1.30 bar when the speed is more than 2,300 rpm.

Multiply the above-mentioned values by 1.40 when fluids other than Antiwear Petroleum base fluids are used.

The difference between inlet pressure and atmospheric pressure should not exceed 0.2 bar to prevent aeration. Inlet Pressure is considered with petroleum base fluids at viscosities of between 10 and 65 cSt.





SINGLE VANE PUMPS

BH*, V* and DT6 single vane pumps

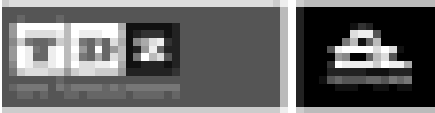

BH* SINGLE VANE PUMP ORDERING CODE

| | | | | | | | |
|----|-----|---|----|---|---|---|----|
| F3 | BHQ | 4 | 67 | D | 1 | A | 00 |
| 1 | 2 | 3 | 4 | 5 | 6 | 7 | 8 |

1- "F3" means special seals for fire-resistant fluids. Omit if not required.

2- Pump Type:

- BHP = 10 vane pump**, industrial and mobile use, BSP, NPT & SAE threads. Only BHP1 and BHP2
- BHS = 12 vane pump**, industrial use (very quiet), metric threads.
- BHQ = 10 vane pump and bronze plates**, mobile use, metric threads.

3- **Pump model:** 1 and 2 in BHP types; 4, 6 and 7 in BHS and BHQ types.

4- **Flow:** BHP, BHS and BHQ in Litres per minute at 1000 rpm and 7 Bar.

5- **D = Right - hand** direction of rotation (Clockwise).
Y = Left - hand direction of rotation. (Counterclockwise).
 (To check the direction of rotation view from the shaft end).

6- **Shaft type:** See on each pump model.

7- Outlet position, (viewed from shaft):

- A: Outlet in line with inlet.
- B: 90° on the right from inlet (Clockwise from inlet).
- C: 180° from inlet.
- D: 90° on the left from inlet (90° counter clock wise from inlet).

8- Special characteristics

Omit if not required

- Example:
- 02: BSP
 - 03: UNF
 - 04: NPT

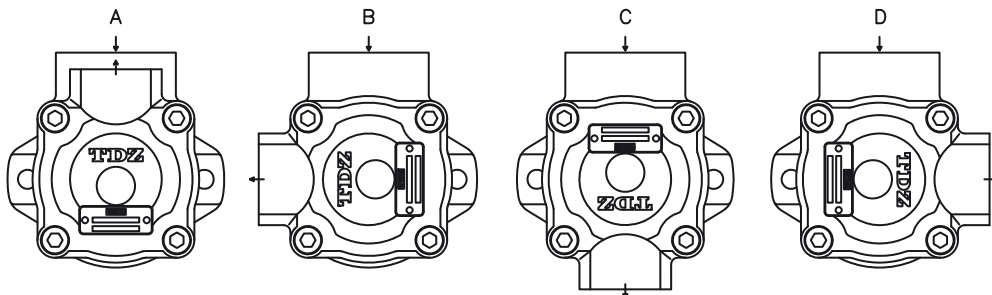



BH*SINGLE VANE PUMP CHARACTERISTICS

TDZ DESIGN VANE PUMPS

| TYPE | FLOW | | | SPEED (rpm) | | PRESSURE (Bar) | | Nominal Power (2) | CONNECTION | | WEIGHT (Kgs.) | | | | | |
|--------------|-----------------|------------------|---------------|-------------|-----------------------|----------------|-----------------------|-------------------|------------|--------|---------------|-----|------|-----|-----|------|
| | Lts.at 1000 rpm | Gal. At 1200 rpm | Reduction (1) | Min. | Máx. | Contin. | Intermit. | | Inlet | Outlet | | | | | | |
| BHP1 | 2 | 0,6 | 0,18 | 600 | 2500 | 150 | 175 | 0,5 | (4) | (4) | 1 | | | | | |
| | 3 | 0,9 | 0,18 | | | | | 0,7 | | | | | | | | |
| | 4,5 | 1,2 | 0,36 | | | | | 1 | | | | | | | | |
| | 5,5 | 1,7 | 0,36 | | | | | 1,4 | | | | | | | | |
| | 6,5 | 2 | 0,36 | | | | | 1,6 | | | | | | | | |
| BHP2 | 7 | 2,2 | 0,7 | 600 | 2500 | 150 | 175 | 1,8 | (4) | (4) | 3,6 | | | | | |
| | 8 | 2,5 | 1,1 | | | | | 2 | | | | | | | | |
| | 10 | 3,2 | 1,1 | | | | | 2,5 | | | | | | | | |
| | 12 | 3,8 | 1,1 | | | | | 3 | | | | | | | | |
| | 15 | 4,7 | 1,1 | | | | | 3,7 | | | | | | | | |
| BHS4 BHQ4 | 26 | 8 | 4,5 | 600 | 2500 1800 (BHS) | 175 | 210 | 6,9 | Ø38 | Ø26 | 14,5 | | | | | |
| | 40 | 12 | 5,7 | | | | | 10,4 | | | | | | | | |
| | 45 | 14 | 5,7 | | | | | 11,6 | | | | | | | | |
| | 55 | 17 | 5,8 | | | | | 13,8 | | | | | | | | |
| | 60 | 19 | 5,8 | | | | | 14,6 | | | | | | | | |
| | 67 | 21 | 6 | | 16,8 | | | | | | | | | | | |
| | 80 | 24 | 6,2 | | 20,3 | | | | | | | | | | | |
| | 88* | 27* | 6,5 | | 22,4 | | | | | | | | | | | |
| | BHS6 BHQ6 | 66 | 21 | | 8,6 | 600 | 2400 1800 (BHS) | 175 | | | | 210 | 16,8 | Ø60 | Ø32 | 26,3 |
| | | 81 | 25 | | 9 | | | | | | | | 20,3 | | | |
| 97 | | 30 | 10 | 24,3 | | | | | | | | | | | | |
| 112 | | 35 | 11,4 | 27,4 | | | | | | | | | | | | |
| 121 | | 38 | 11,4 | 29,3 | | | | | | | | | | | | |
| 142 | 45 | 13,1 | 33,3 | | | | | | | | | | | | | |
| BHS7 BHQ7 | 138 | 42 | 15 | 600 | 2200 1800 (BHS) | 155 | 175 | 32,3 | Ø75 | Ø38 | 38,3 | | | | | |
| | 148 | 47 | 15,7 | | | | | 36,3 | | | | | | | | |
| | 162 | 50 | 14,3 | | | | | 37,9 | | | | | | | | |
| | 180 | 57 | 17,9 | | | | | 43,2 | | | | | | | | |
| | 193 | 60 | 18,6 | | | | | 46,1 | | | | | | | | |
| | 214 | 67 | 22 | | | | | 51,2 | | | | | | | | |
| | 240 | 75 | 26 | | | | | 57,4 | | | | | | | | |

*27 gallons (88 lts.) cartridge not mounted in BHQ4 vane pump model.

(1) **Delivery flow reduction** in Ltrs./min. at 100 Bar. 22 cST of oil viscosity at operating temperature. To calculate the approximate delivery flow at a given pressure and speed, use the following formula with flow reduction and theoretical flow values shown in the chart. Flow reduction values are independent of shaft speed.

$$\text{Approx. output flow (Ltrs./min.)} = \text{Theoretical flow} \times \frac{\text{R.P.M}}{1000} - \text{Reduction} \times \frac{\text{Pressure (Bar)}}{1000}$$

(2) **Nominal Power** in H.P. at 100 Bar and 1000 RPM (to convert into Kw multiply by 0.735). To obtain the real input power at different pressure and revolutions, use the formula as follows:

$$\text{Real input power} = \text{Input power} \times \frac{\text{R.P.M}}{1000} \times \frac{\text{Pressure (Bar)}}{1000}$$

(3) See options on dimension pages.



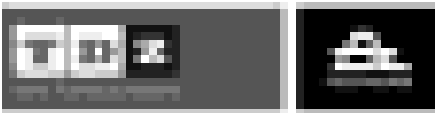

SINGLE VANE PUMP TYPE BHP-1

DATA SHEET

| FLOW | | | | | | SPEED (rpm) | | PRES (BAR) | | CONNECTION | | WEIGHT (Kgs.) |
|-----------------|-----|-----|-----|-----|-----|-------------|------|------------|-----------|------------|--------|---------------|
| Lts at 1000 rpm | 2 | 3 | 4,5 | 5,5 | 6,5 | Min. | Máx. | Contin. | Intermit. | Inlet | Outlet | |
| Gal at 1200 rpm | 0,6 | 0,9 | 1,2 | 1,7 | 2 | 600 | 2500 | 175 | 210 | Ø38 | Ø26 | 1 |

DIMENSIONS IN MILLIMETERS 1" = 25.4 mm

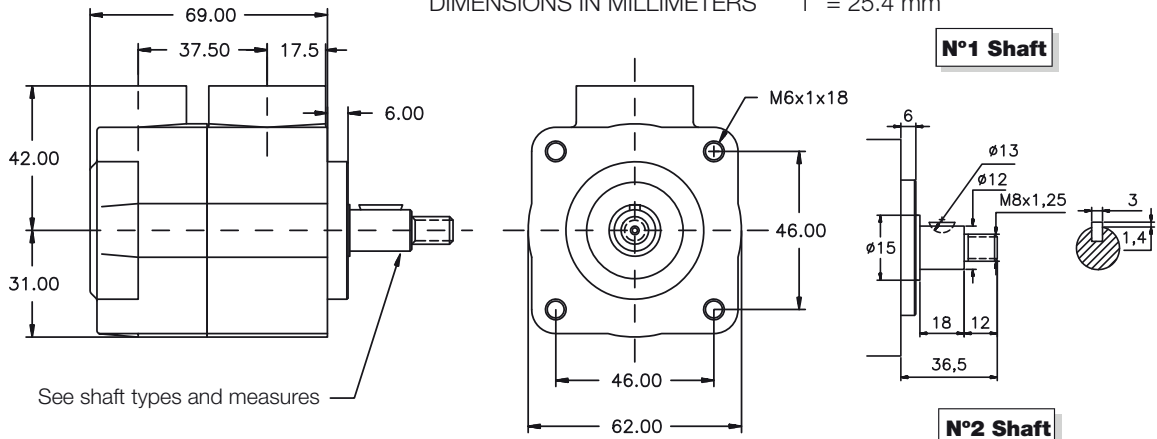

See shaft types and measures

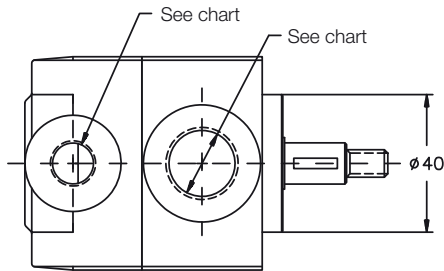

See chart

See chart

| Num. | Inlet | Outlet |
|------|----------|----------|
| 01 | 1/2" BSP | 1/4" BSP |
| 02 | 3/8" BSP | 1/4" BSP |

BHP1 PUMP AND FRAME SET TO CONNECT TO ELECTRIC MOTOR

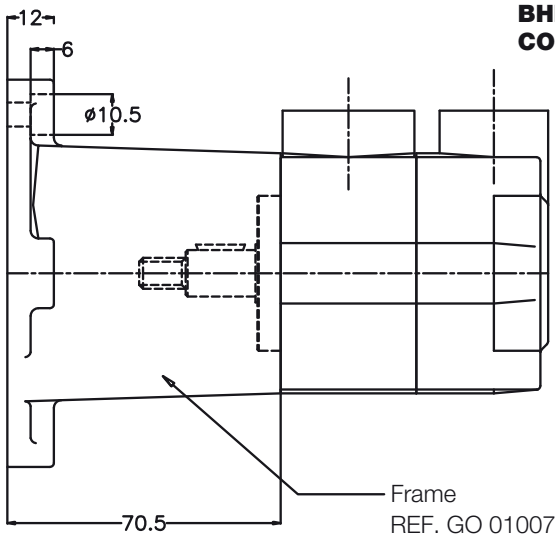

Frame
REF. GO 01007

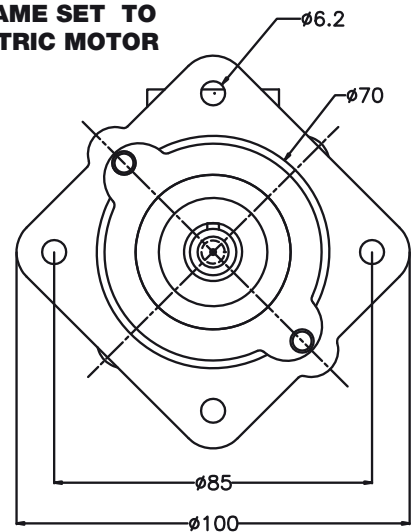



SINGLE VANE PUMP TYPE BHP-1

FLOW AND INPUT POWER DIAGRAMS

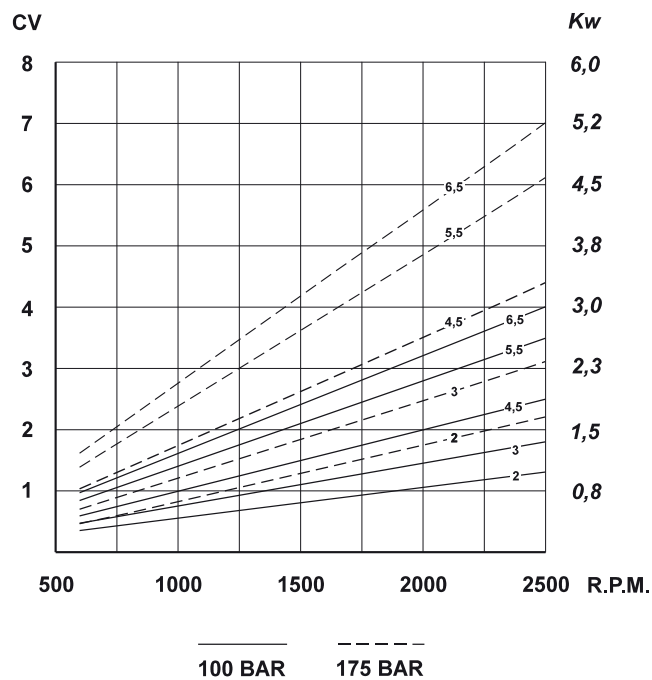
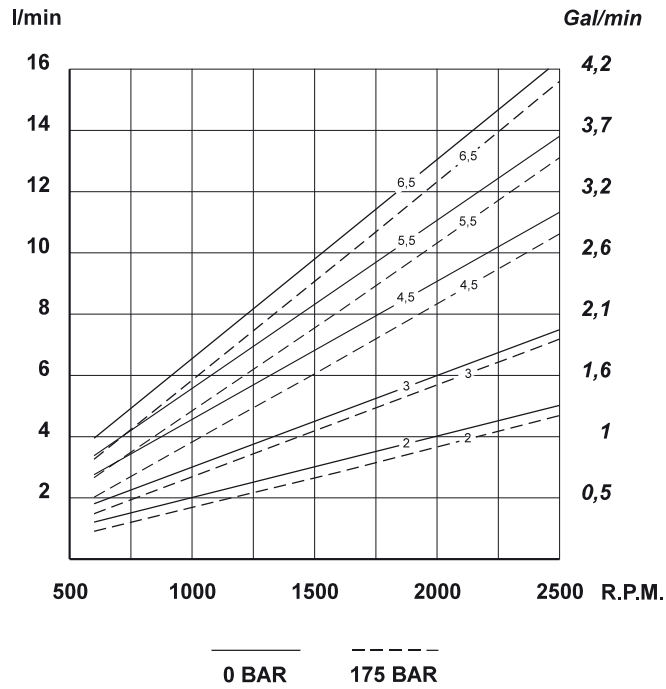

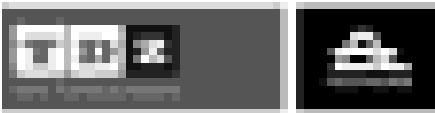

SINGLE VANE PUMP TYPE BHP-2

| FLOW | SPEED (rpm) | | | | | PRES (BAR) | | CONNECTION | | WEIGHT (Kgs.) | | |
|-----------------|-----------------|-----|-----|-----|-----|------------|-------|------------|--------|---------------|-----------|-------|
| | Lts at 1000 rpm | 7 | 8 | 10 | 12 | 15 | Mín. | Máx. | Contin | | Intermit. | Inlet |
| Gal at 1200 rpm | 2,2 | 2,5 | 3,2 | 3,8 | 4,7 | 600 | 2500* | 150 | 175 | 3/4" BSP | 1/2" BSP | 3,6 |

* For further details see general chart

DIMENSIONS IN MILLIMETERS 1" = 25.4 mm

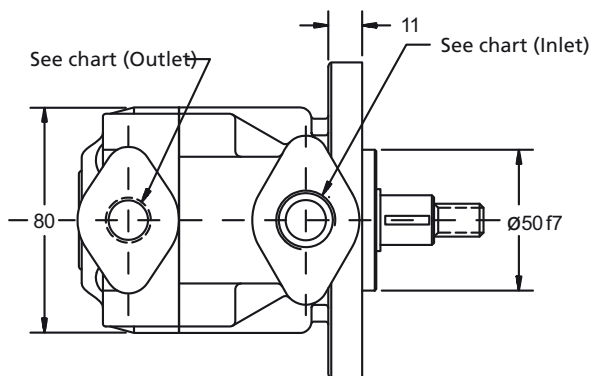
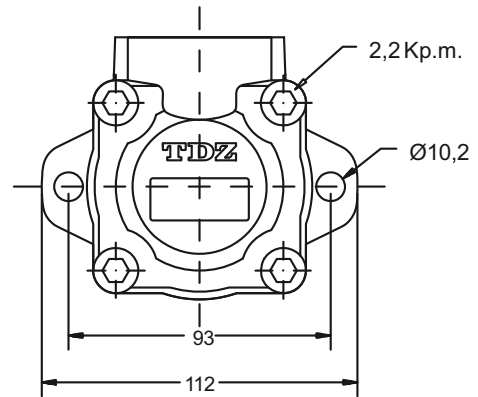
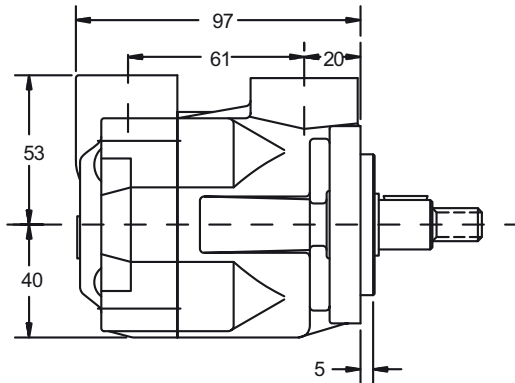

| Num. | Inlet | Outlet |
|------|----------|----------|
| 02 | 3/4" BSP | 1/2" BSP |

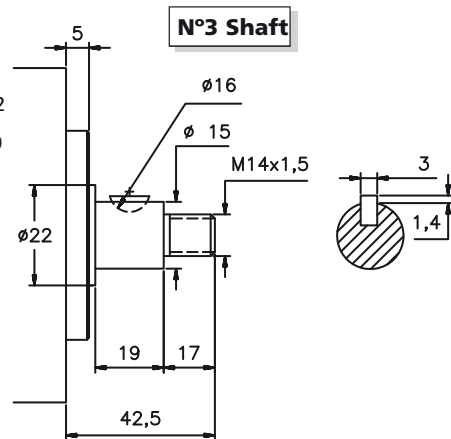
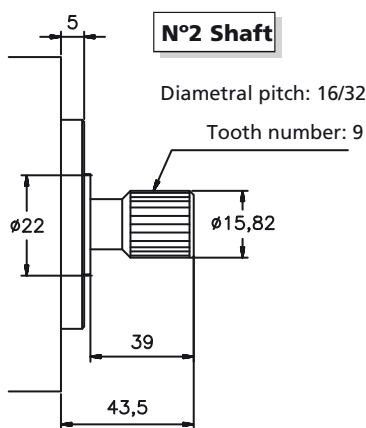
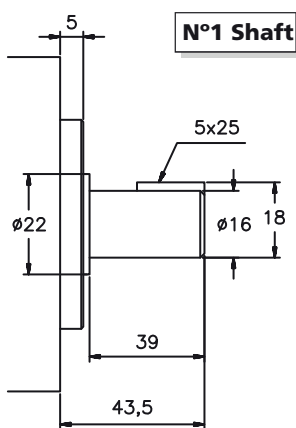



SINGLE VANE PUMP TYPE BHP-2

FLOW AND INPUT POWER DIAGRAMS

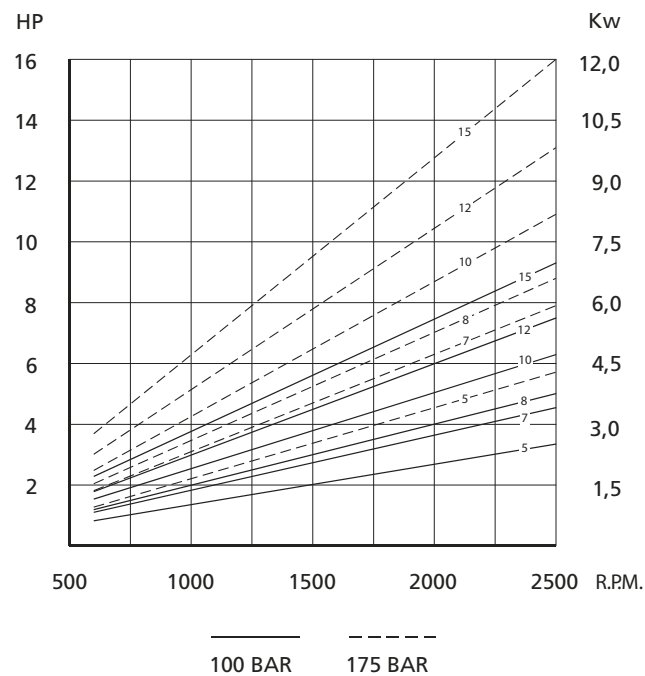
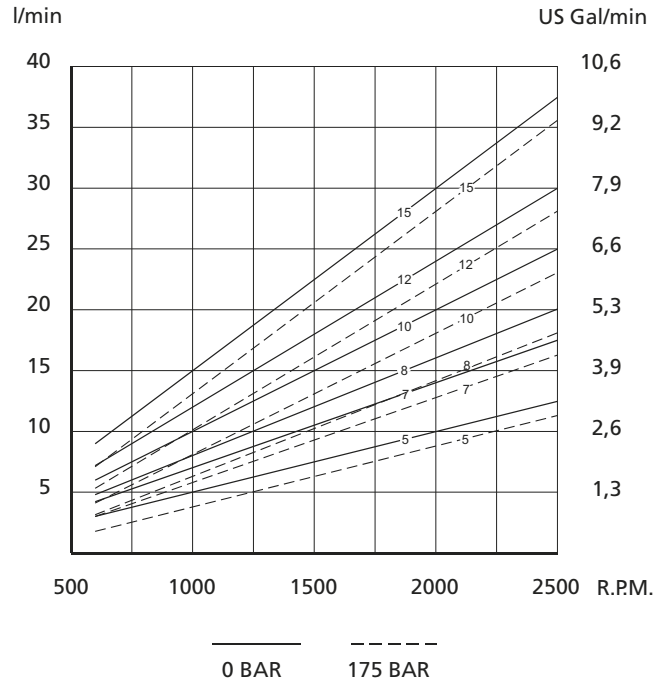

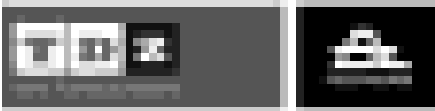

SINGLE VANE PUMP TYPE BHS-4 & BHQ-4

| FLOW | | | | | | | | SPEED (rpm) | | PRES (BAR) | | CONNECTION | | WEIGHT (Kgs.) | |
|-----------------|----|----|----|----|----|----|-----|-------------|------|------------|---------|------------|-------|---------------|--------|
| Lts at 1000 rpm | 26 | 39 | 44 | 54 | 60 | 66 | 80* | 85* | Min. | Máx. | Contín. | Intermit. | Inlet | | Outlet |
| Gal at 1200 rpm | 8 | 12 | 14 | 17 | 19 | 21 | 24* | 27* | 600 | 2500* | 175 | 210* | Ø38 | Ø26 | 14,5 |

* For further details see general chart

DIMENSIONS IN MILLIMETERS 1" = 25.4 mm

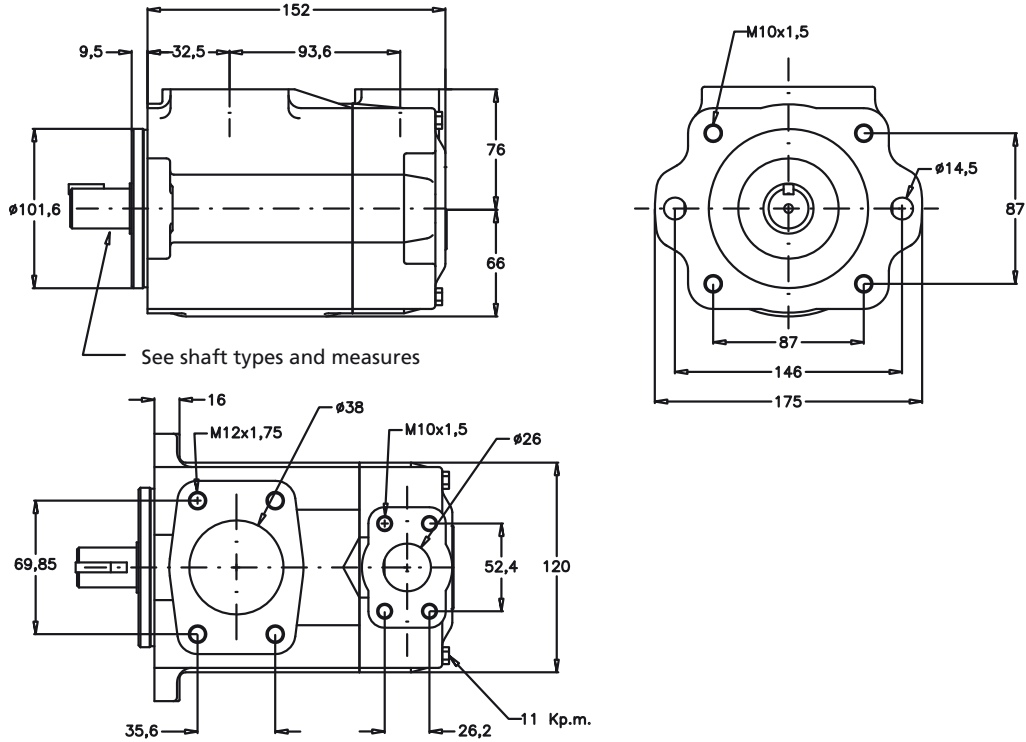

Nº1 Shaft

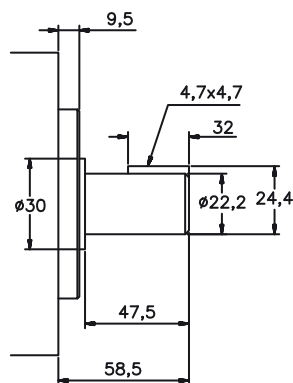

Nº2 Shaft

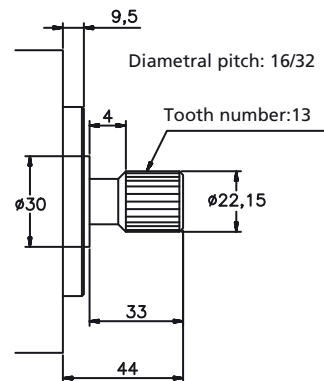

Enquire about other types of shafts





SINGLE VANE PUMP TYPE BHS-4 & BHQ-4

FLOW AND INPUT POWER DIAGRAMS

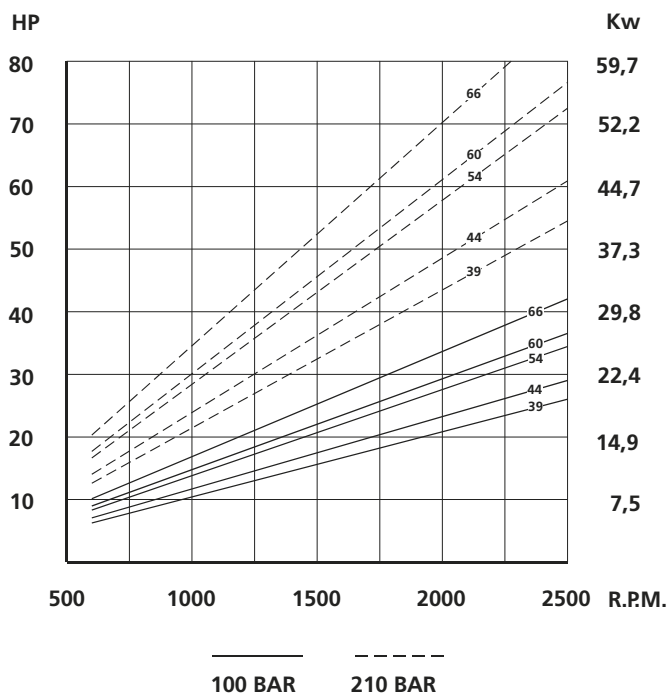
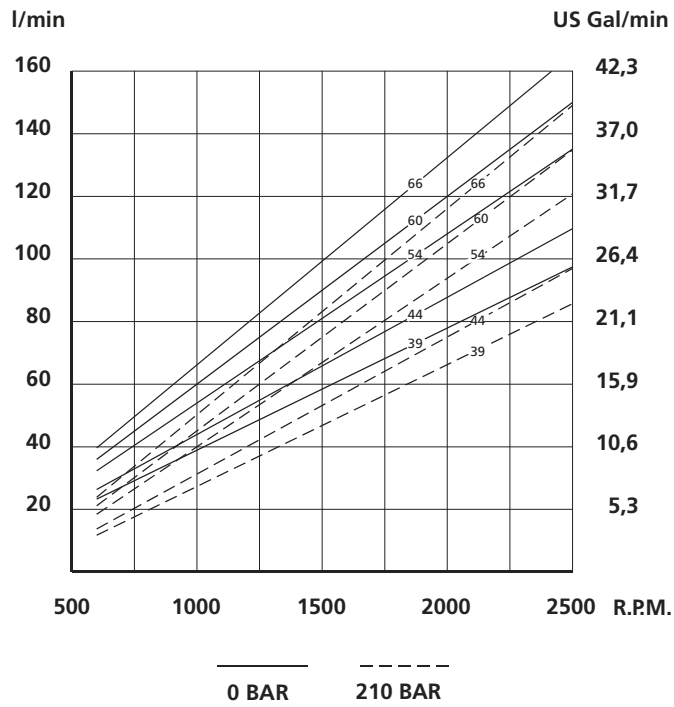

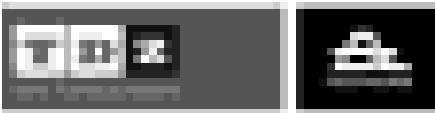

SINGLE VANE PUMP TYPE BHS-6 & BHQ-6

DATA SHEET

| FLOW | SPEED (rpm) | | PRES (BAR) | | CONNECTION | | WEIGHT (Kgs.) |
|-----------------|-------------|-------|------------|-----------|------------|--------|---------------|
| | Min. | Máx. | Contin. | Intermit. | Inlet | Outlet | |
| Lts at 1000 rpm | 66 | 81 | 97 | 112 | 121 | 142* | 26,3 |
| Gal at 1200 rpm | 21 | 25 | 30 | 35 | 38 | 45* | |
| | 600 | 2400* | 175 | 210* | Ø60 | Ø32 | |

* For further details see general chart

DIMENSIONS IN MILLIMETERS 1" = 25.4 mm

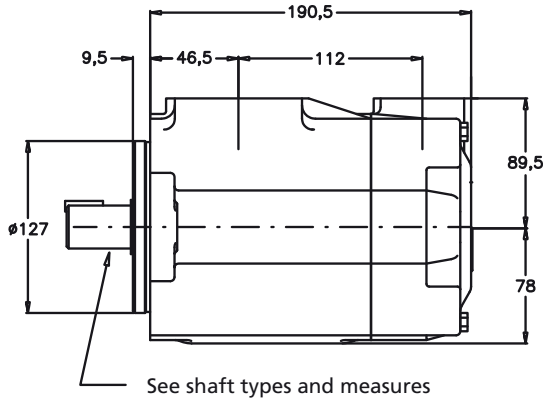

See shaft types and measures

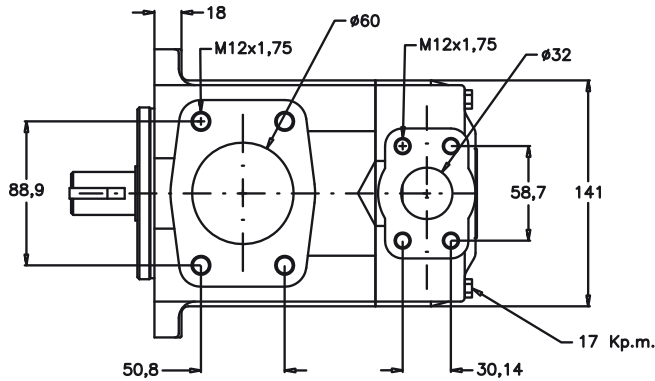
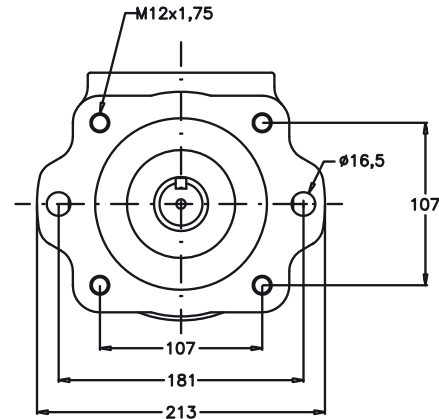

N°1 Shaft

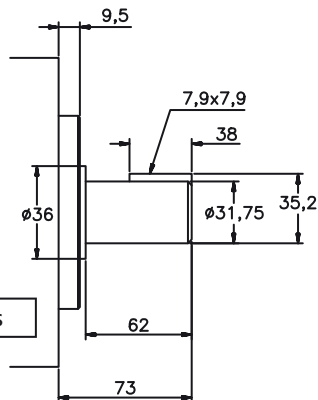

N°2 Shaft

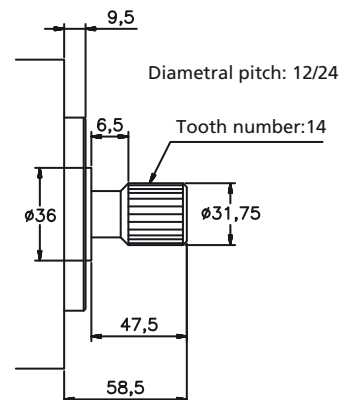

Enquire about other types of shafts





SINGLE VANE PUMP TYPE BHS-6 & BHQ-6

FLOW AND INPUT POWER DIAGRAMS

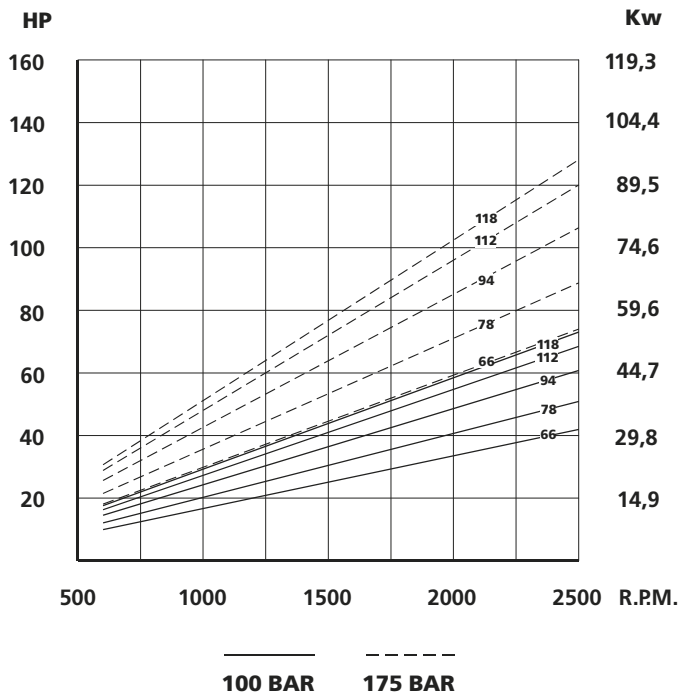
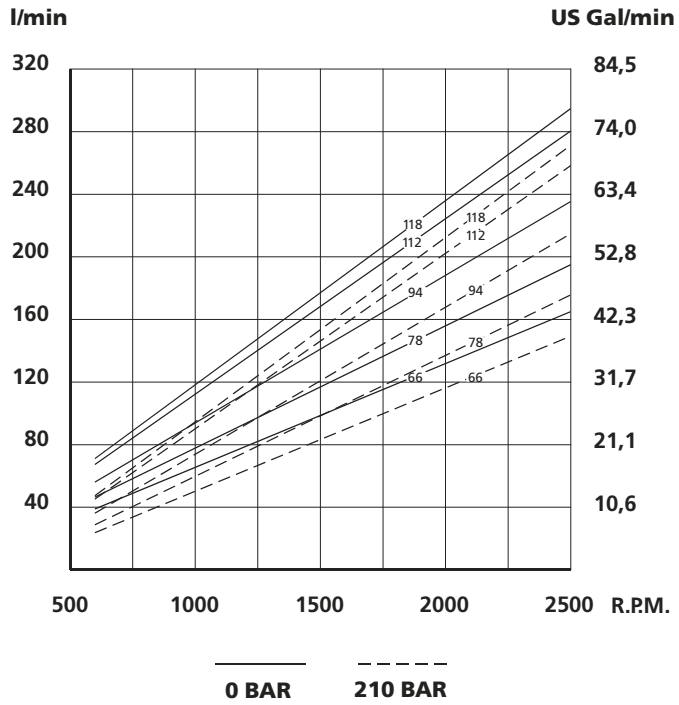



SINGLE VANE PUMP TYPE BHS-7 & BHQ-7

DATA SHEET

| FLOW | SPEED (rpm) | | PRES (BAR) | | CONNECTION | | WEIGHT (Kgs.) | |
|-----------------|-------------|-------|------------|-----------|------------|--------|---------------|------|
| | Mín. | Máx. | Contin | Intermit. | Inlet | Outlet | | |
| Lts at 1000 rpm | 138 | 148 | 162 | 180 | 193 | 214 | 240 | 38,3 |
| Gal at 1200 rpm | 42 | 47 | 50 | 57 | 60 | 67 | 75 | |
| | 600 | 2200* | 155 | 175 | Ø75 | Ø38 | | |

* For further details see general chart

DIMENSIONS IN MILLIMETERS 1" = 25.4 mm

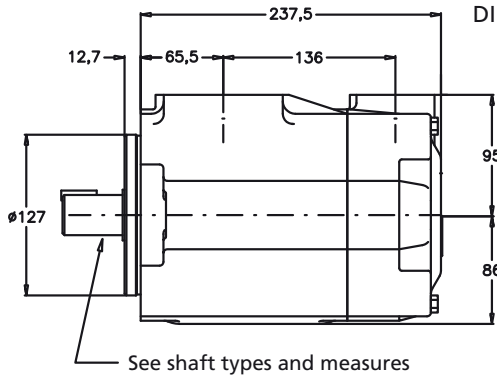

See shaft types and measures

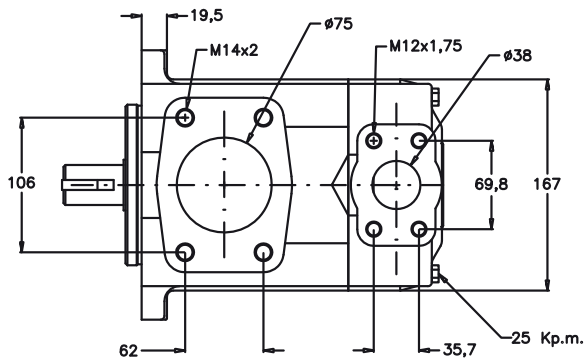
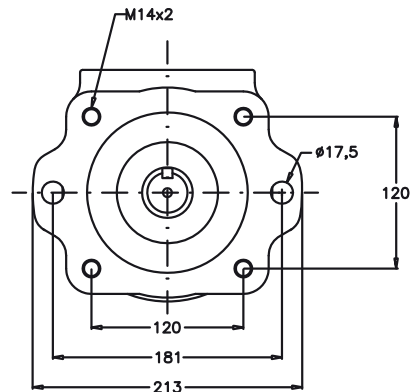

N°1 Shaft

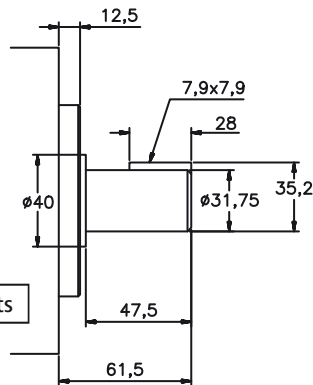

Enquire about other types of shafts

N°2 Shaft

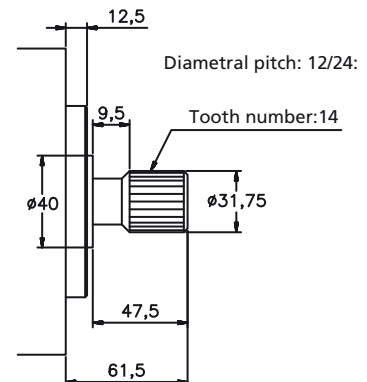



SINGLE VANE PUMP TYPE BHS-7 & BHQ-7

FLOW AND INPUT POWER DIAGRAMS

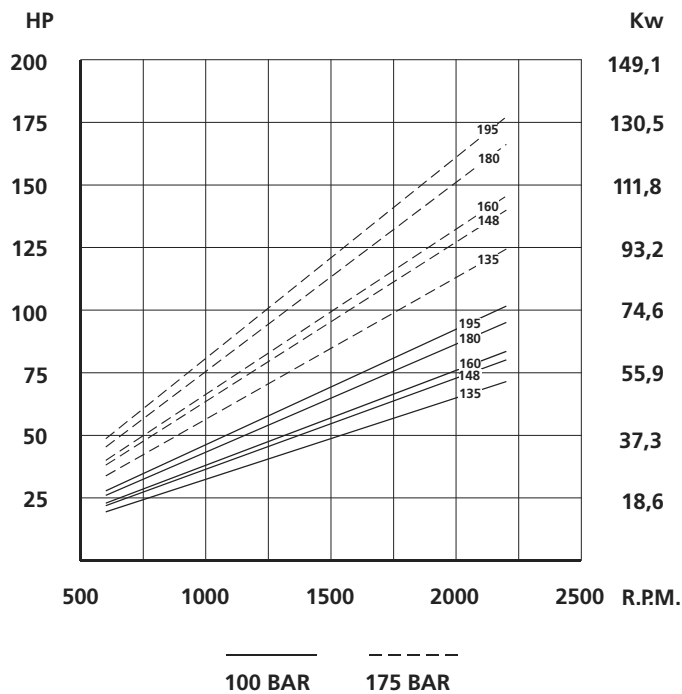
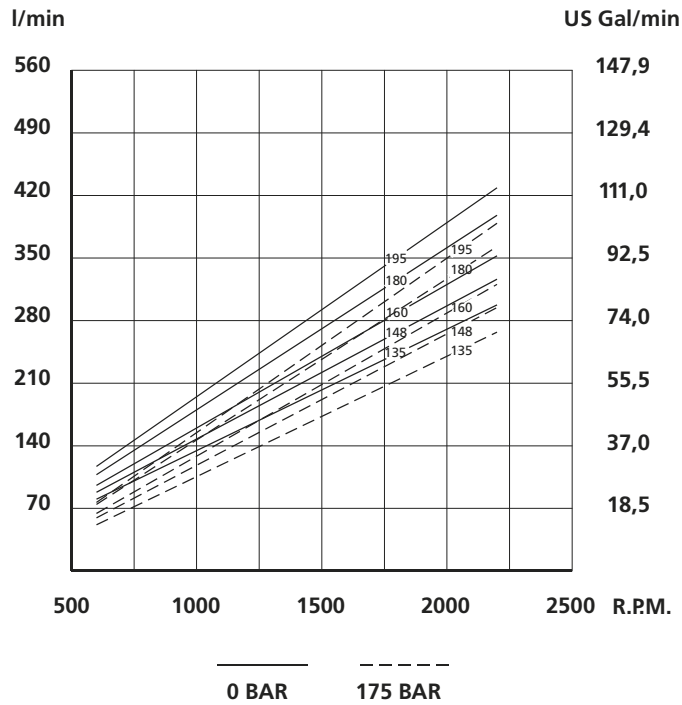



V* SINGLE VANE PUMP ORDERING CODE

| | | | | | | | |
|----|----|----|----|---|---|---|----|
| F3 | VS | 25 | 21 | D | 1 | A | 00 |
| 1 | 2 | 3 | 4 | 5 | 6 | 7 | 8 |

1 - "F3" means special seals for fire-resistant fluids. Omit if not required.

2 - Pump Type:

VC = 12 vane pump (only VC10 and VC20), mobile and industrial use.

VK = 10 vane pump (only VK20), industrial use, UNC threads.

VS = 12 vane pump (VS25, VS35, VS45), industrial use (very quiet), UNC threads.

VQ = 10 vane pump and bronze plates (VQ20, VQ25, VQ35, VQ45), mobile use, UNC threads.

3 - Pump model: VC10, VC20; VK20, VQ20; VS25, VQ25; VS35, VQ35; VS45, VQ45.

4 - Flow: VC, VS and VQ in US Gallons per minute at 1200 rpm and 7 Bar.

5 - D = Right-hand rotation (Clockwise).

Y = Left-hand rotation (Counterclockwise).

(Viewed from shaft end).

6 - Shaft type: See on each pump model.

7 - Outlet position, (viewed from shaft end):

A: Outlet in line with inlet.

B: 90° on the right from inlet (Clockwise from inlet).

C: 180° from inlet.

D: 90° on the left from inlet (90° counterclockwise from inlet).

8- Special characteristic

Omit if not required

Example: 02 : BSP

03 : UNF

04 : NPT

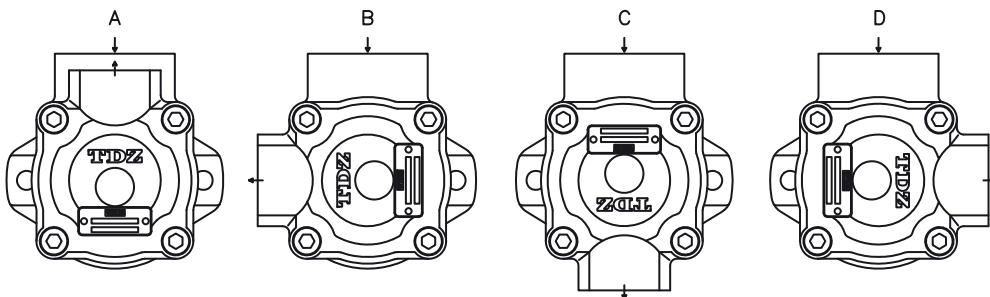



SINGLE VANE PUMP CHARACTERISTICS

VICKERS DESIGN VANE PUMPS

| TYPE | FLOW | | | SPEED (rpm) | | PRESSURE (Bar) | | Nominal Power (2) | CONNECTION | | WEIGHT (Kgs.) |
|--------------|-----------------|-----------------|---------------|-------------|----------------------|----------------|----------|-------------------|------------|--------|---------------|
| | Lts.at 1000 rpm | Gal.at 1200 rpm | Reduction (1) | Min. | Máx. | Contin. | Intermit | | Inlet | Outlet | |
| | | | | | | | | | | | |
| VC10 | 3 | 1 | 0,8 | 600 | 4800 | 155 | 180 | 0,7 | (3) | (3) | 4,5 |
| | 6 | 2 | 0,9 | | 4500 | | | 1,4 | | | |
| | 9 | 3 | 1,2 | | 4000 | | | 2,1 | | | |
| | 13 | 4 | 1,6 | | 3400 | | | 2,7 | | | |
| | 16 | 5 | 1,7 | | 3200 | | | 3,2 | | | |
| | 19 | 6 | 1,8 | | 3000 | | | 3,7 | | | |
| | 22 | 7 | 1,9 | | 2800 | | | 4,2 | | | |
| VC20 | 19 | 6 | 2,8 | 600 | 3400 | 155 | 180 | 3,9 | (3) | (3) | 7,3 |
| | 22 | 7 | 4,2 | | 3000 | | | 4,4 | | | |
| | 26 | 8 | 4,5 | | 2800 | | | 5,1 | | | |
| | 29 | 9 | 4,8 | | 2800 | | | 5,6 | | | |
| | 36 | 11 | 4,8 | | 2500 | | | 6,5 | | | |
| | 39 | 12 | 5,4 | | 2400 | | | 7,5 | | | |
| | 42 | 13 | 6,0 | | 2400 | | | 8,1 | | | |
| VK20 VQ20 | 8 | 2 | 0,9 | 600 | 2600 | 175 | 210 | 1,9 | Ø1½" | Ø3/4" | 12 |
| | 18 | 5 | 2,1 | | | | | 4 | | | |
| | 27 | 8 | 2,8 | | | | | 6,6 | | | |
| | 29 | 9 | 3,5 | | | | | 6,9 | | | |
| | 36 | 11 | 4,3 | | | | | 7,3 | | | |
| | 39 | 12 | 4,3 | | | | | 7,4 | | | |
| | 46 | 14 | 5,3 | | | | | 7,6 | | | |
| VS25 VQ25 | 26 | 8 | 4,5 | 600 | 2500 1800 (VS) | 175 | 210 | 6,9 | Ø1½" | Ø1" | 15 |
| | 40 | 12 | 5,7 | | | | | 10,4 | | | |
| | 45 | 14 | 5,7 | | | | | 11,6 | | | |
| | 55 | 17 | 5,8 | | | | | 13,8 | | | |
| | 60 | 19 | 5,8 | | | | | 14,6 | | | |
| | 67 | 21 | 6 | | | | | 16,8 | | | |
| | 80 | 24 | 6,2 | | | | | 20,3 | | | |
| 88* | 27 | 6,5 | 1500 | 125 | 150 | 21,1 | | | | | |
| VS35 VQ35 | 66 | 21 | 8,6 | 600 | 2400 1800 (VS) | 175 | 210 | 16,8 | Ø2" | Ø1¼" | 23 |
| | 81 | 25 | 9 | | | | | 20,3 | | | |
| | 97 | 30 | 10 | | | | | 24,3 | | | |
| | 112 | 35 | 11,4 | | | | | 27,4 | | | |
| | 121 | 38 | 11,4 | | | | | 29,3 | | | |
| | 142 | 45 | 13,1 | | | | | 33,3 | | | |
| | 1500 | 125 | 150 | | | | | 33,3 | | | |
| VS45 VQ45 | 138 | 42 | 15 | 600 | 2200 1800 (VS) | 155 | 175 | 32,3 | Ø3" | Ø1½" | 35,5 |
| | 148 | 47 | 15,7 | | | | | 36,3 | | | |
| | 162 | 50 | 14,3 | | | | | 37,9 | | | |
| | 180 | 57 | 17,9 | | | | | 43,2 | | | |
| | 193 | 60 | 18,6 | | | | | 46,1 | | | |
| | 214 | 67 | 22 | | | | | 51,2 | | | |
| | 240 | 75 | 26 | | | | | 57,4 | | | |

*27 gallons (88 lts.) cartridge not mounted in VQ25 vane pump model.

(1) **Delivery flow reduction** in Ltrs./min. at 100 Bar. 22 cST of oil viscosity at operating temperature. To calculate the approximate delivery flow at a given pressure and speed, use the following formula with flow reduction and theoretical flow values shown in the chart. Flow reduction values are independent of shaft speed.

$$\text{Approx. output flow (Ltrs./min.)} = \text{Theoretical flow} \times \frac{\text{R.P.M}}{1000} - \text{Reduction} \times \frac{\text{Pressure (Bar)}}{1000}$$

(2) **Nominal Power** in H.P. at 100 Bar and 1000 RPM (to convert into Kw multiply by 0.735).

To obtain the real input power at different pressure and revolutions, use the formula as follows:

$$\text{Real input power} = \text{Input power} \times \frac{\text{R.P.M}}{1000} \times \frac{\text{Pressure (Bar)}}{1000}$$

(3) See options on dimension pages.



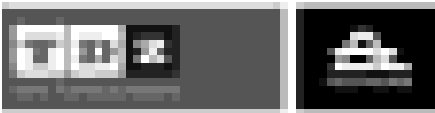

SINGLE VANE PUMP TYPE VC-10

DIMENSIONS IN MILLIMETERS. 1" = 25,4 mm

| FLOW | | | SPEED (rpm) | | PRESSURE (Bar) | | Nominal Power (2) | CONNECTION | | WEIGHT (Kgs.) |
|-----------------|-----------------|---------------|-------------|------|----------------|-----------|-------------------|------------|----------|---------------|
| Lts.at 1000 rpm | Gal.at 1200 rpm | Reduction (1) | Min. | Máx. | Contin. | Intermit. | | Inlet | Outlet | |
| 3 | 1 | 0,8 | 600 | 4800 | 155 | 180 | 0,7 | 1" NPT | 1/2" NPT | 4,5 |
| 6 | 2 | 0,9 | | 4500 | | | | | | |
| 9 | 3 | 1,2 | | 4000 | | | | | | |
| 13 | 4 | 1,6 | | 3400 | | | | | | |
| 16 | 5 | 1,7 | | 3200 | | | | | | |
| 19 | 6 | 1,8 | | 3000 | | | | | | |
| 22 | 7 | 1,9 | | 2800 | | | 140 | | | |

(1) & (2) see page 27.

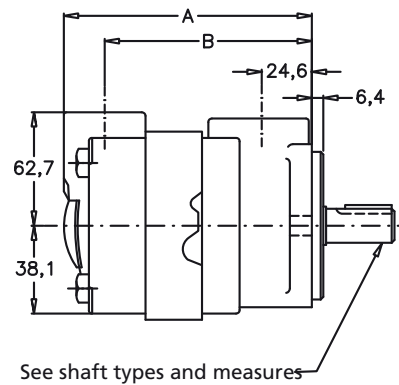
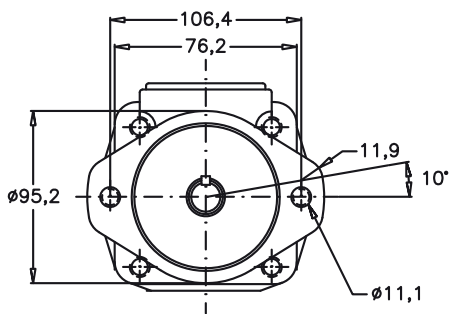

| Gallons | Dimension | |
|---------|-----------|-------|
| | A | B |
| 1, 2, 3 | 115,6 | 91,9 |
| 4, 5 | 121,9 | 98,3 |
| 6, 7 | 127 | 103,4 |

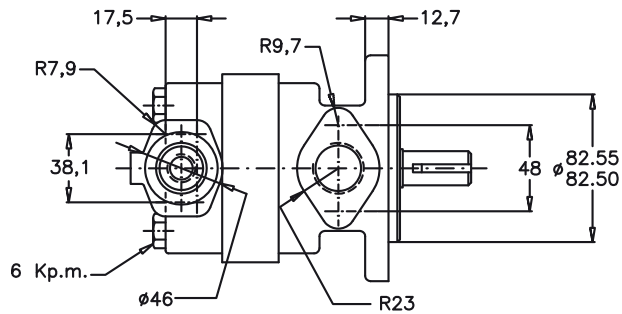

| Num. | Inlet | Outlet |
|------|--------|----------|
| 02 | 1" BSP | 1/2" BSP |
| 04 | 1" NPT | 1/2" NPT |

Contact **TDZ** or your nearest distributor for other shaft types

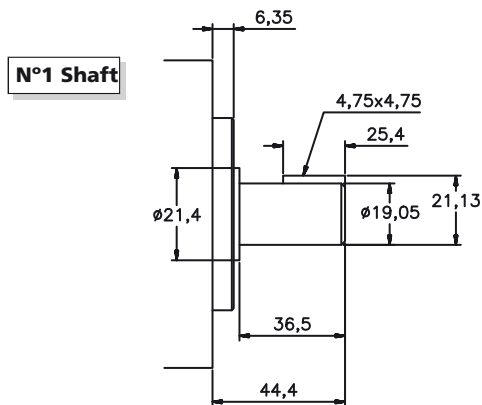



SINGLE VANE PUMP TYPE VC-10



FLOW AND INPUT POWER DIAGRAMS

Max. pressure (180 bar)

Pressure (7 bar)

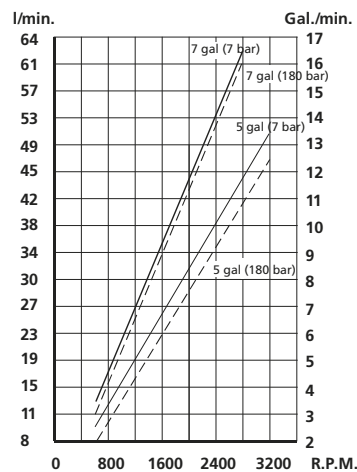
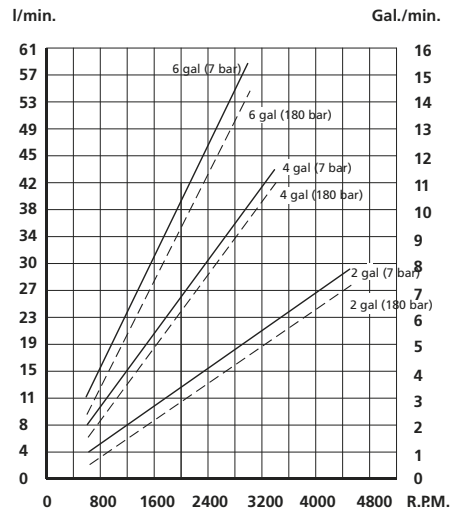
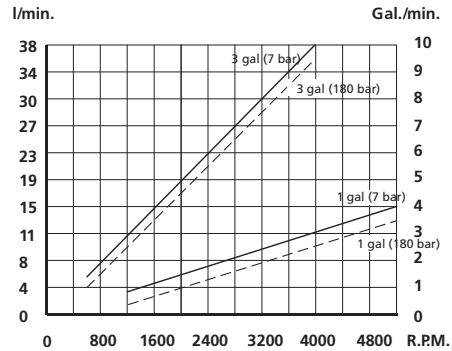
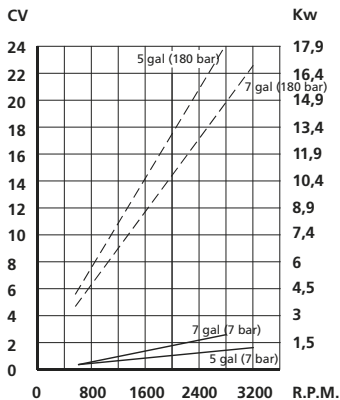
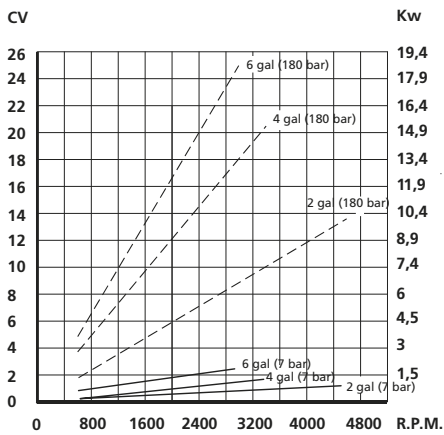
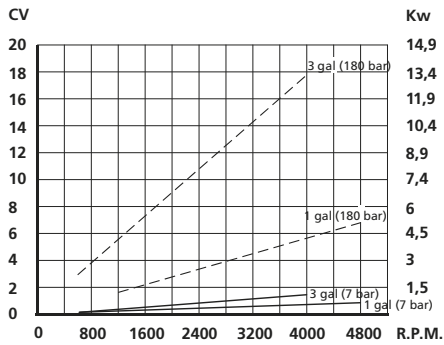

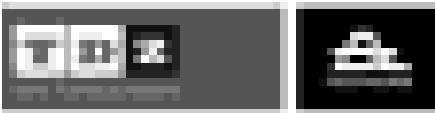

SINGLE VANE PUMP TYPE VC-20

DIMENSIONS IN MILLIMETERS. 1" = 25,4 mm

| FLOW | | | SPEED (rpm) | | PRES (BAR) | | Nominal Power (2) | CONNECTION | | WEIGHT (Kgs.) |
|-----------------|-----------------|---------------|-------------|------|------------|----------|-------------------|------------|----------|---------------|
| Lts.at 1000 rpm | Gal.at 1200 rpm | Reduction (1) | Min. | Max. | Contin. | Intermit | | Inlet | Outlet | |
| 19 | 6 | 2,8 | 600 | 3400 | 155 | 180 | 3,9 | 1 1/4" NPT | 3/4" NPT | 7,3 |
| 22 | 7 | 4,2 | | 3000 | | | 4,4 | | | |
| 26 | 8 | 4,5 | | 2800 | | | 5,1 | | | |
| 29 | 9 | 4,8 | | 2800 | | | 5,6 | | | |
| 36 | 11 | 4,8 | | 2500 | | | 6,5 | | | |
| 39 | 12 | 5,4 | | 2400 | | | 7,5 | | | |
| 42 | 13 | 6,0 | | 2400 | | | 8,1 | | | |

(2) & (3) see page 27.

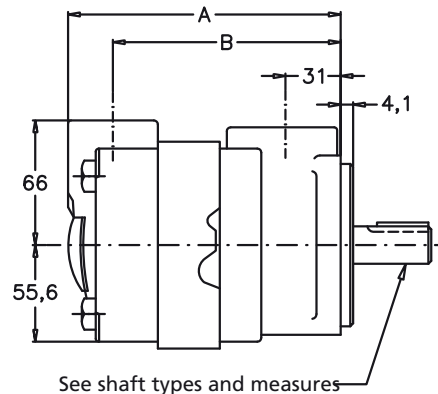
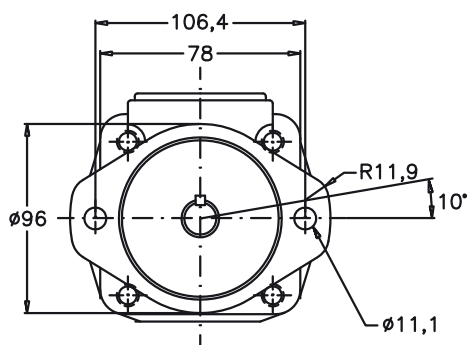

| Galon | Dimension | |
|---------|-----------|-------|
| | A | B |
| 6 | 125,2 | 102,1 |
| 7, 8, 9 | 131,6 | 108,4 |
| 11 | 136,7 | 113,5 |
| 12, 13 | 140,2 | 117,1 |

| Num. | Inlet | Outlet |
|------|------------|----------|
| 02 | 1" 1/4 BSP | 3/4" BSP |
| 04 | 1" 1/4 NPT | 3/4" NPT |

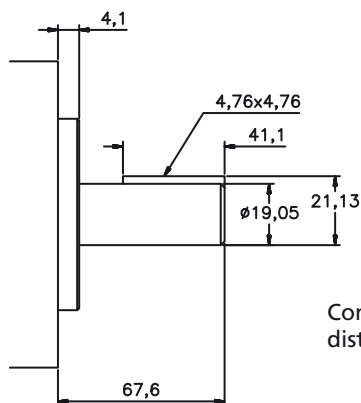
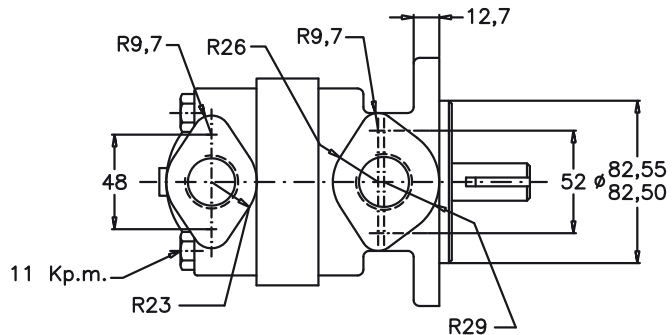

Contact **TDZ** or your nearest distributor for other shaft types





SINGLE VANE PUMP TYPE VC-20



FLOW AND INPUT POWER DIAGRAMS

----- Max. pressure (180 bar) _____ Min. Pressure (7 bar)

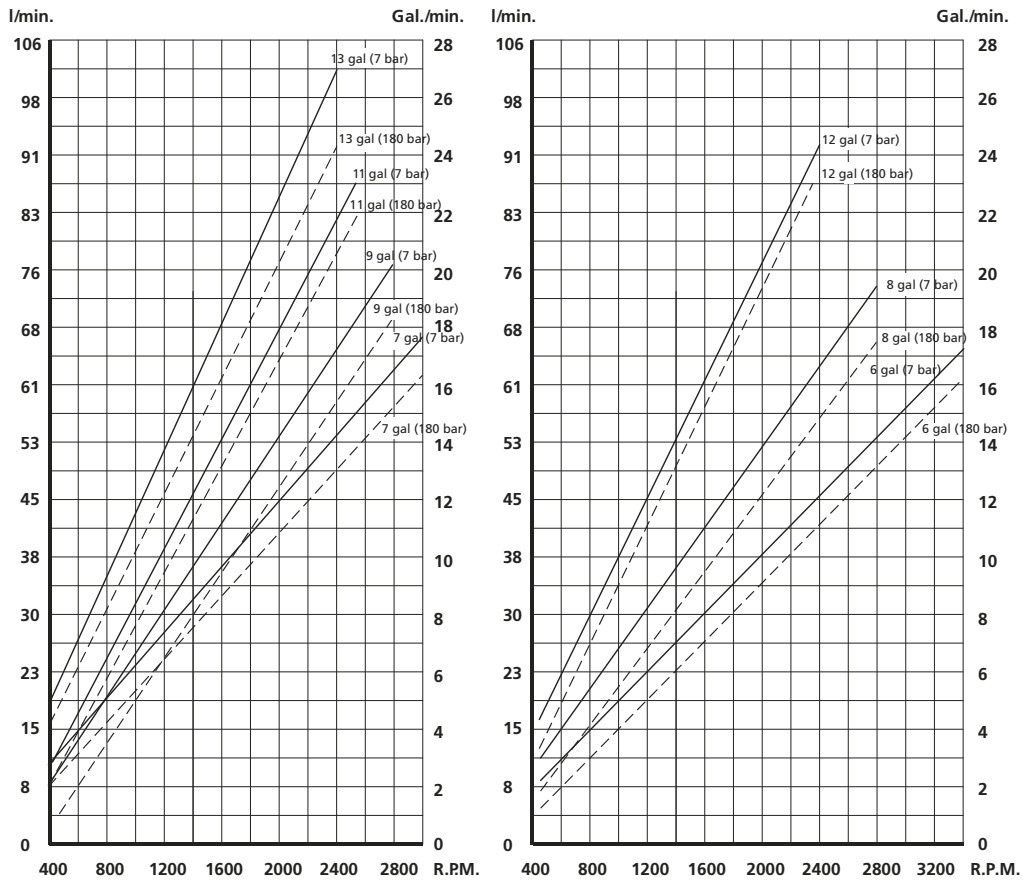
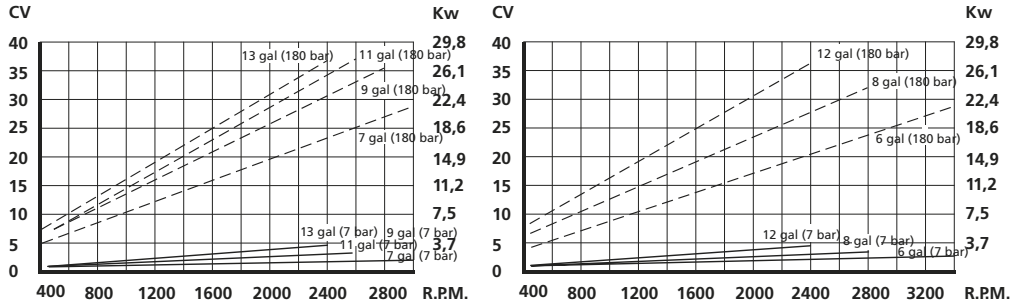

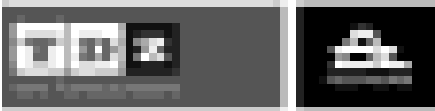

SINGLE VANE PUMP TYPE VK-20 Y VQ-20

DIMENSIONS IN MILLIMETERS. 1" = 25,4 mm

| FLOW | FLOW | | | | | | SPEED (rpm) | | PRES (BAR) | | CONNECTION | | WEIGHT (Kgs.) | |
|-----------------|-----------------|---|----|----|----|----|-------------|-----|------------|------|------------|-----------|---------------|-------|
| | Lts.at 1000 rpm | 8 | 18 | 27 | 29 | 36 | 39 | 46 | Min. | Max. | Contin. | Intermit. | | Inlet |
| Gal.at 1200 rpm | 2 | 5 | 8 | 9 | 11 | 12 | 14 | 600 | 2500 | 175 | 210 | Ø 1 1/2" | Ø 3/4" | 12 |

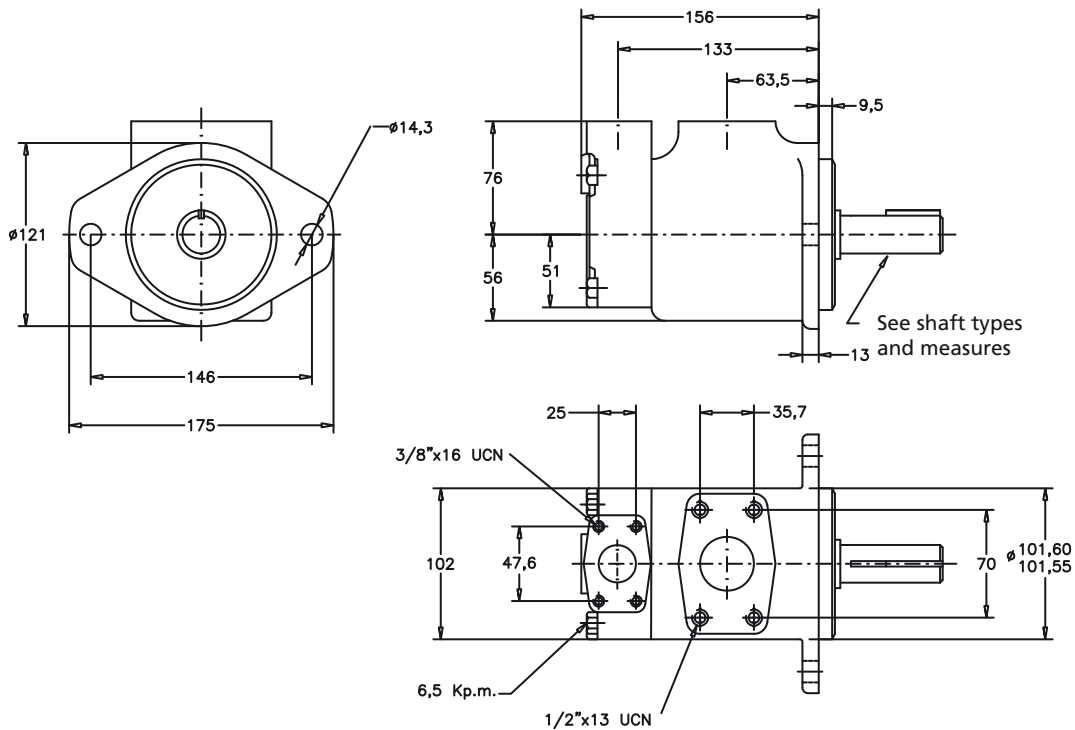

N°1 Shaft

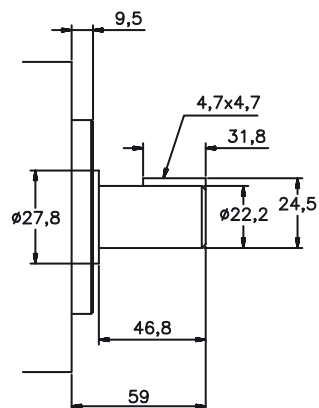

N°151 Shaft

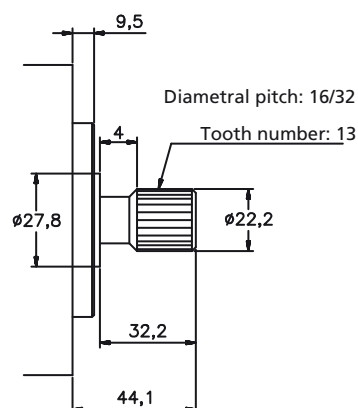



SINGLE VANE PUMP TYPE VK-20 Y VQ-20



FLOW AND INPUT POWER DIAGRAMS

----- Max. pressure (210 bar) _____ Min. Pressure (7 bar)

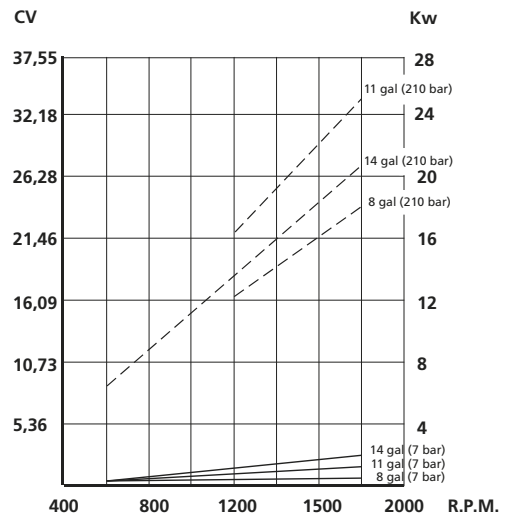
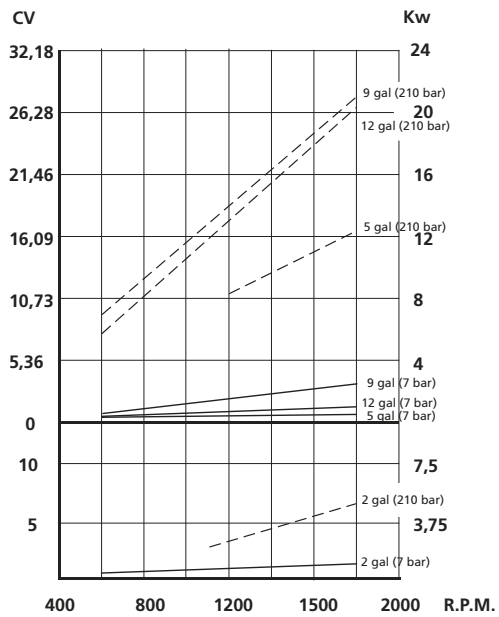
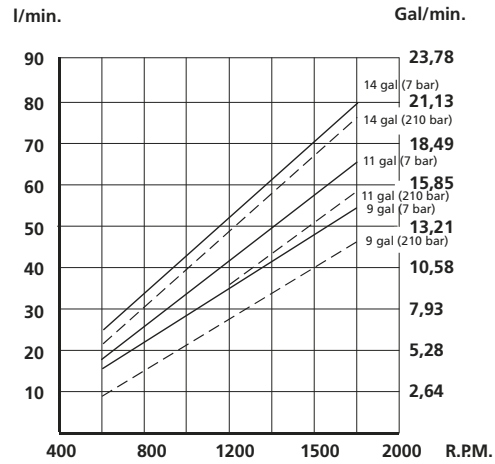
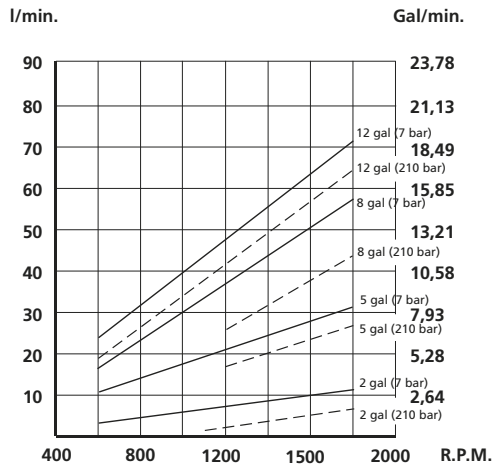

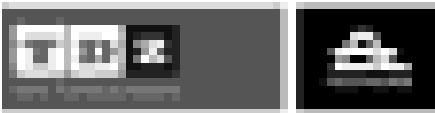

SINGLE VANE PUMP TYPE VS-25 & VQ-25

| FLOW | | | | | | | | SPEED(rpm) | | PRES (BAR) | | CONNECTION | | WEIGHT | |
|-----------------|----|----|----|----|----|----|-----|------------|------|------------|---------|------------|--------|--------|--------|
| Lts.at 1000 rpm | 26 | 40 | 45 | 55 | 60 | 67 | 80* | 88* | Min. | Max. | Contin. | Intermit. | Inlet | Outlet | (Kgs.) |
| Gal.at 1200 rpm | 8 | 12 | 14 | 17 | 19 | 21 | 24* | 27* | 600 | 2500* | 175 | 210* | Ø1"1/2 | Ø1" | 15 |

*See page 27.

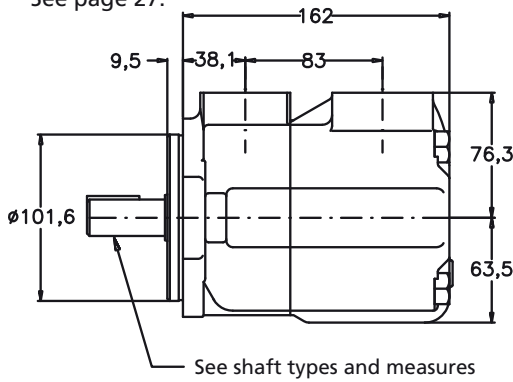

DIMENSIONS IN MILLIMETERS 1" = 25.4 mm

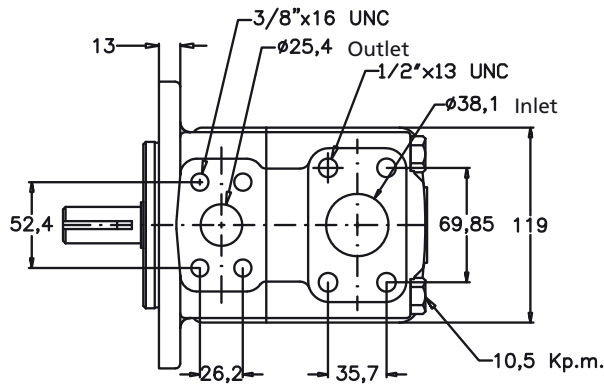
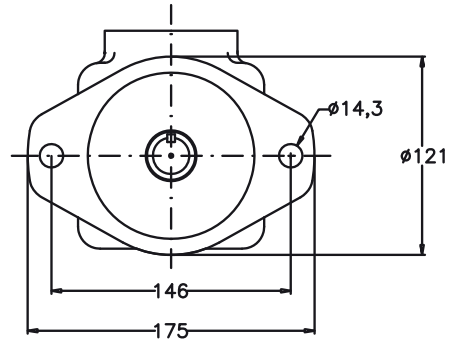

N°1 Shaft

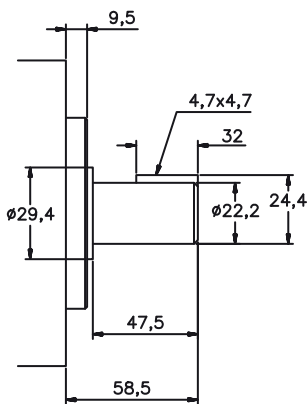

N°11 Shaft

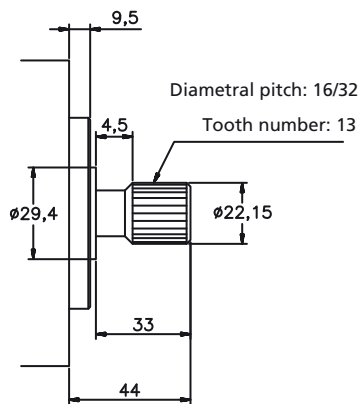

N°86 Shaft

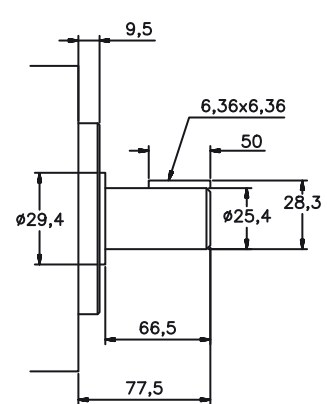

Enquire about other types of shafts





SINGLE VANE PUMP TYPE VS-25 & VQ-25



FLOW AND INPUT POWER DIAGRAMS

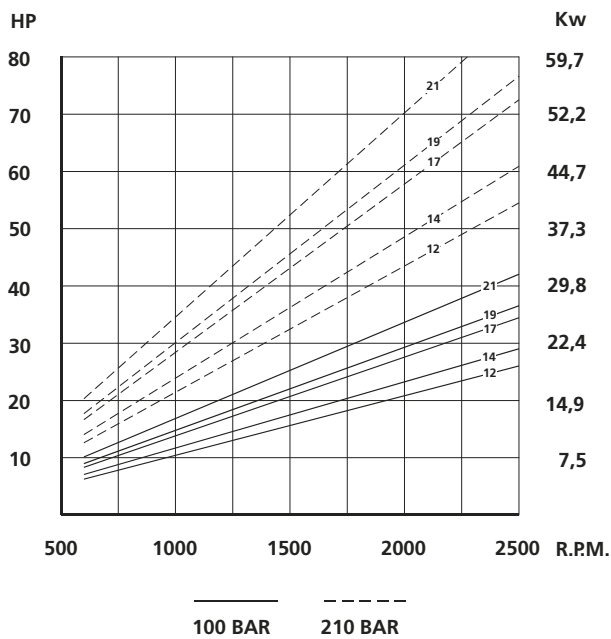
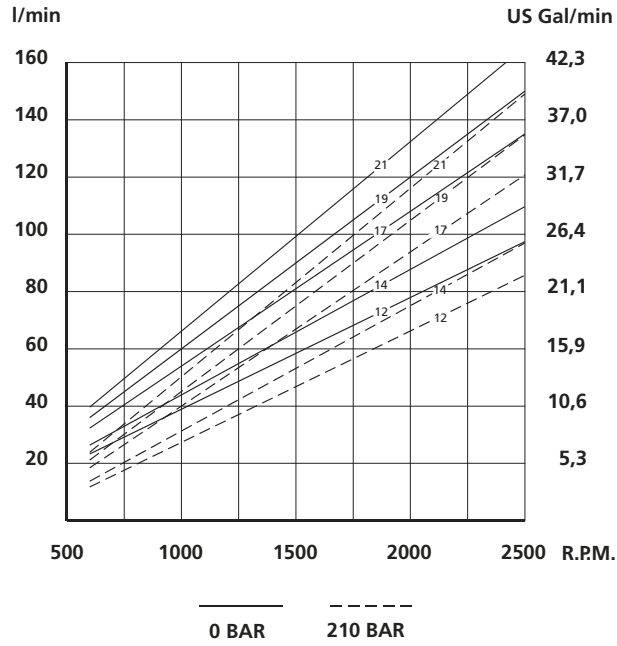

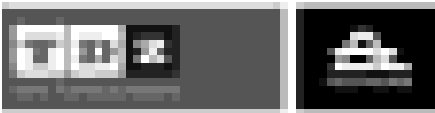

SINGLE VANE PUMP TYPE VS-35 & VQ-35

DATA SHEET

| FLOW | SPEED (rpm) | | PRES (BAR) | | CONNECTION | | WEIGHT (Kgs.) |
|-----------------|-------------|------|------------|-----------|------------|--------|---------------|
| | Min. | Max. | Contin. | Intermit. | Inlet | Outlet | |
| Lts.at 1000 rpm | 66 | 81 | 97 | 112 | 121 | 142* | 23 |
| Gal.at 1200 rpm | 21 | 25 | 30 | 35 | 38 | 45* | |

*See page 27.

* For further details see general chart

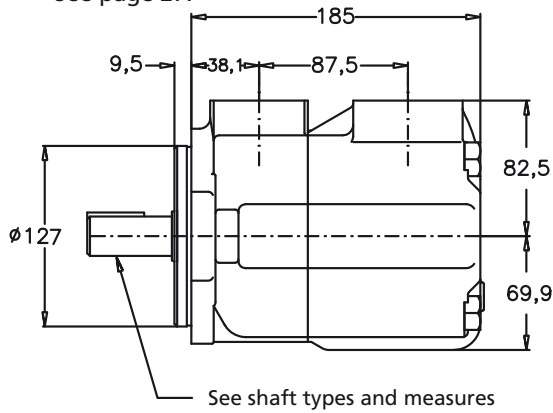

DIMENSIONS IN MILLIMETERS 1" = 25.4 mm

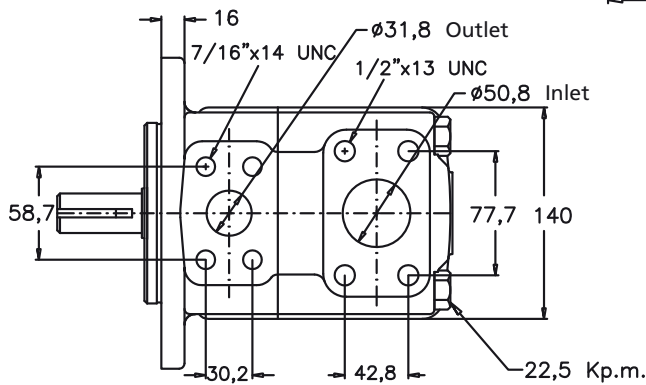
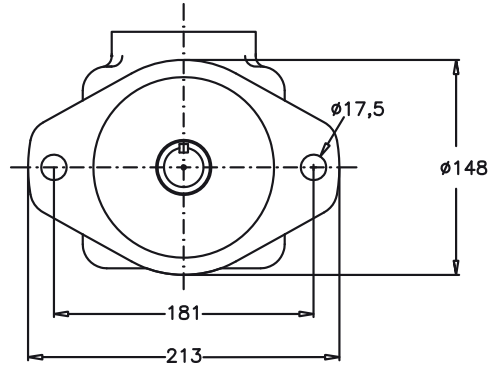

N°1 Shaft

N°11 Shaft

N°86 Shaft

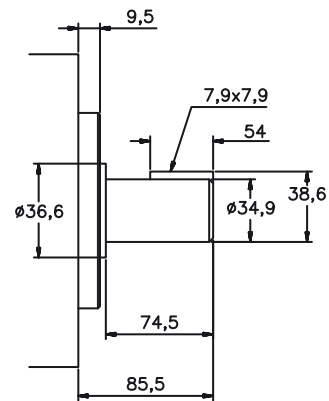
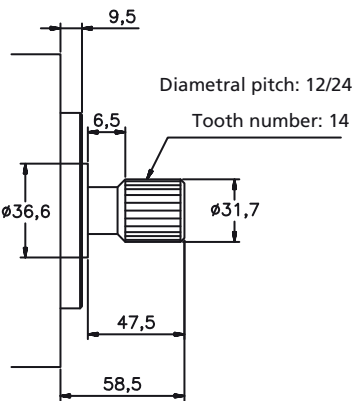
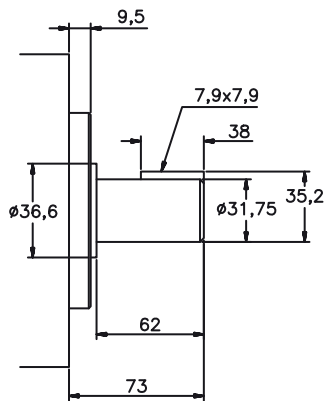

Enquire about other types of shafts





SINGLE VANE PUMP TYPE VS-35 & VQ-35



FLOW AND INPUT POWER DIAGRAMS

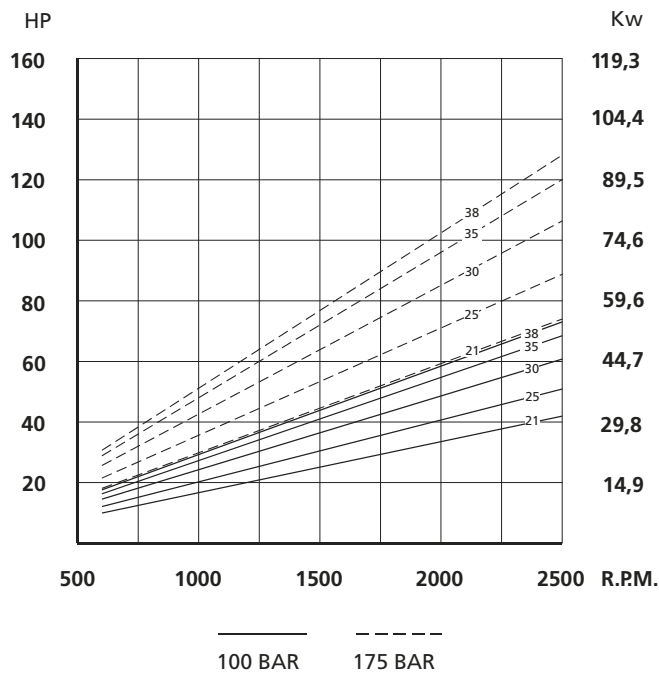
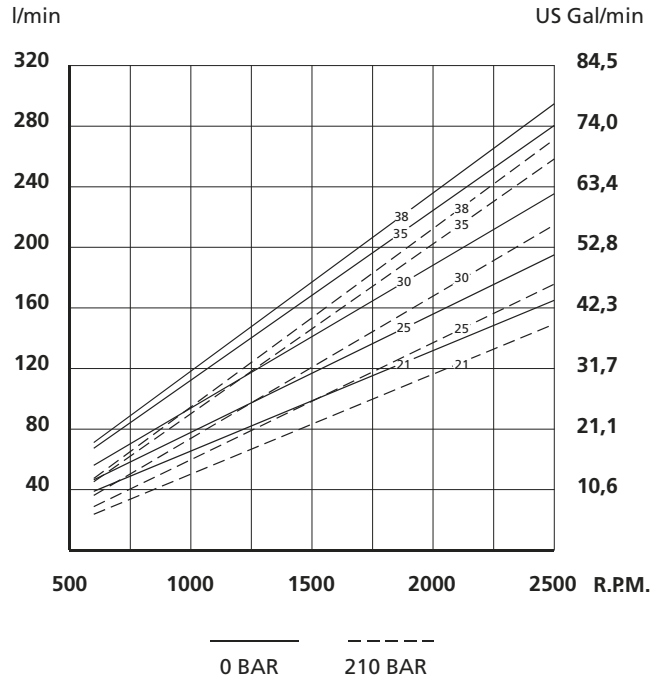

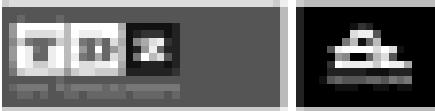

SINGLE VANE PUMP TYPE VS-45 & VQ-45

DATA SHEET

| FLOW | SPEED (rpm) | | PRES (BAR) | | CONNECTION | | WEIGHT (Kgs.) |
|-----------------|-------------|-------|------------|-----------|------------|---------|---------------|
| | Min. | Máx. | Contin. | Intermit. | Inlet | Outlet | |
| Lts. a 1000 rpm | 138 | 148 | 162 | 180 | 193 | 214 | 240 |
| Gal. a 1200 rpm | 42 | 47 | 50 | 57 | 60 | 67 | 75 |
| | 600 | 2200* | 155 | 175 | Ø3" | Ø1" 1/2 | 35,5 |

* For further details see general chart

DIMENSIONS IN MILLIMETERS 1" = 25.4 mm

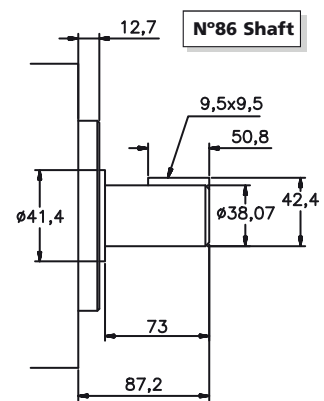
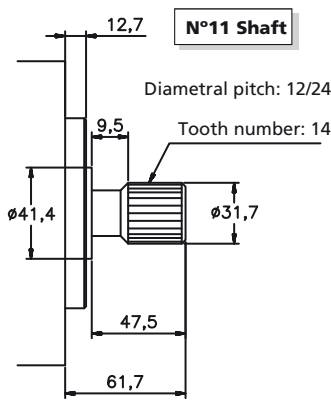
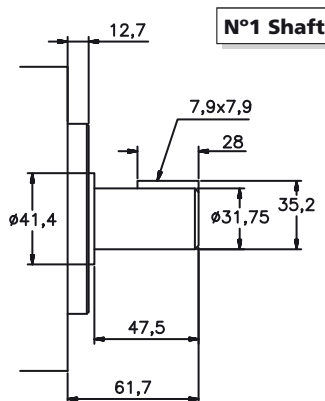
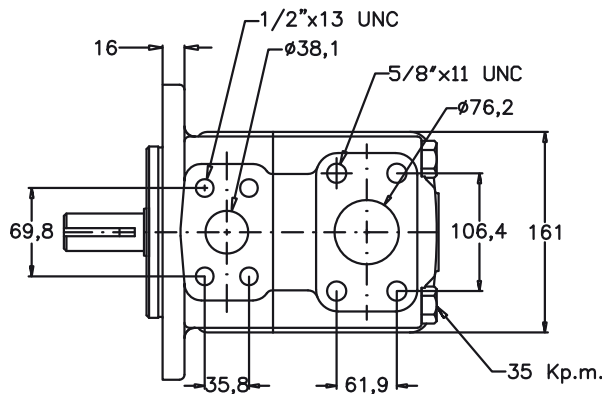
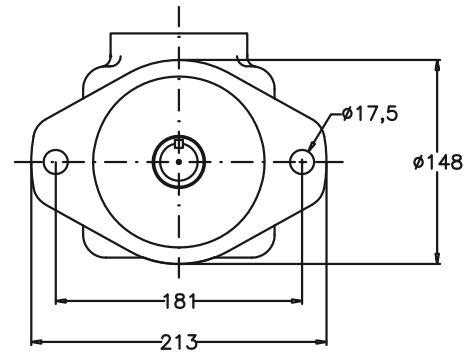
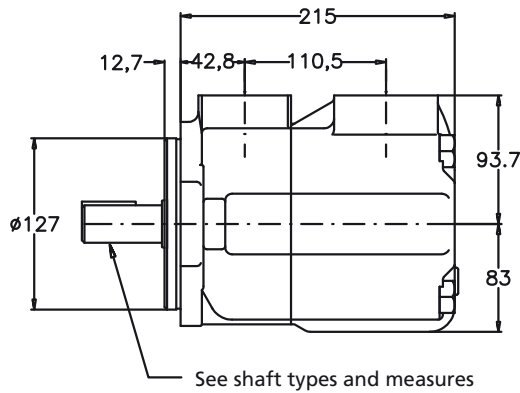

Enquire about other types of shafts



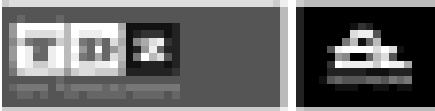

SINGLE VANE PUMP TYPE VS-45 & VQ-45

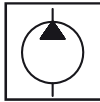

FLOW AND INPUT POWER DIAGRAMS

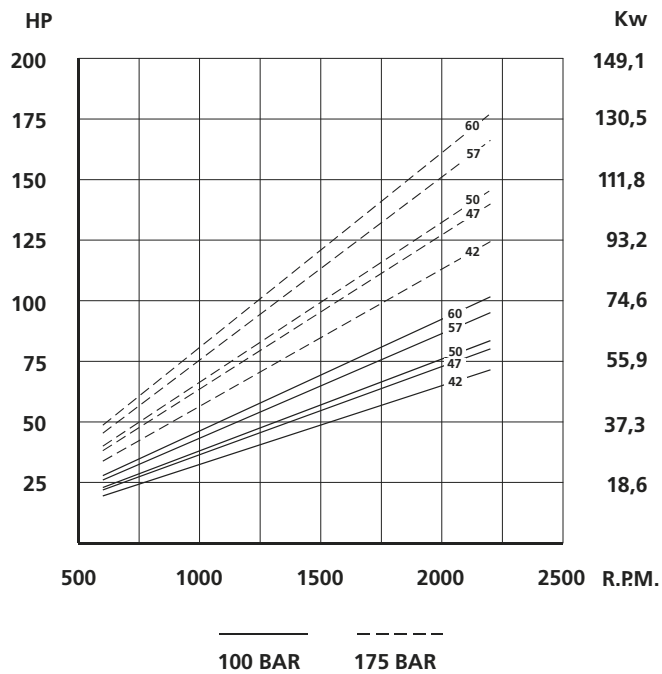
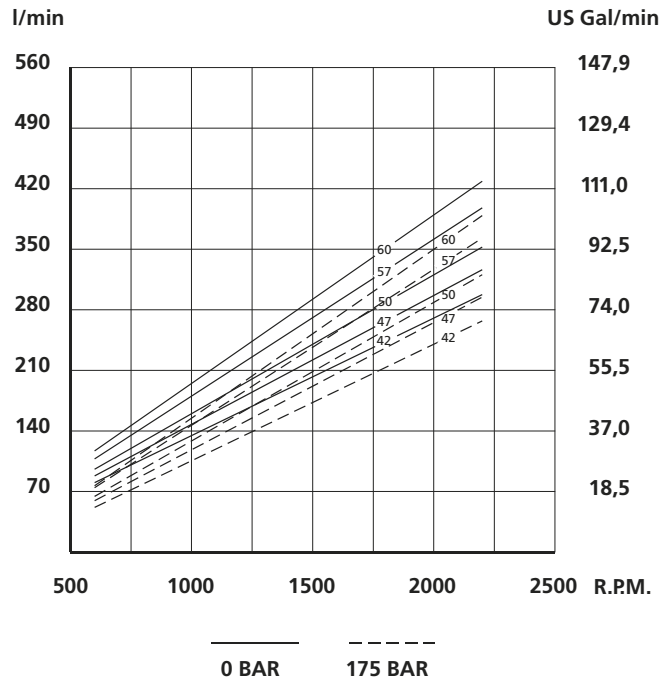



DT6 SINGLE VANE PUMPS

DT6 SINGLE VANE PUMPS ORDERING CODE

DATA SHEET

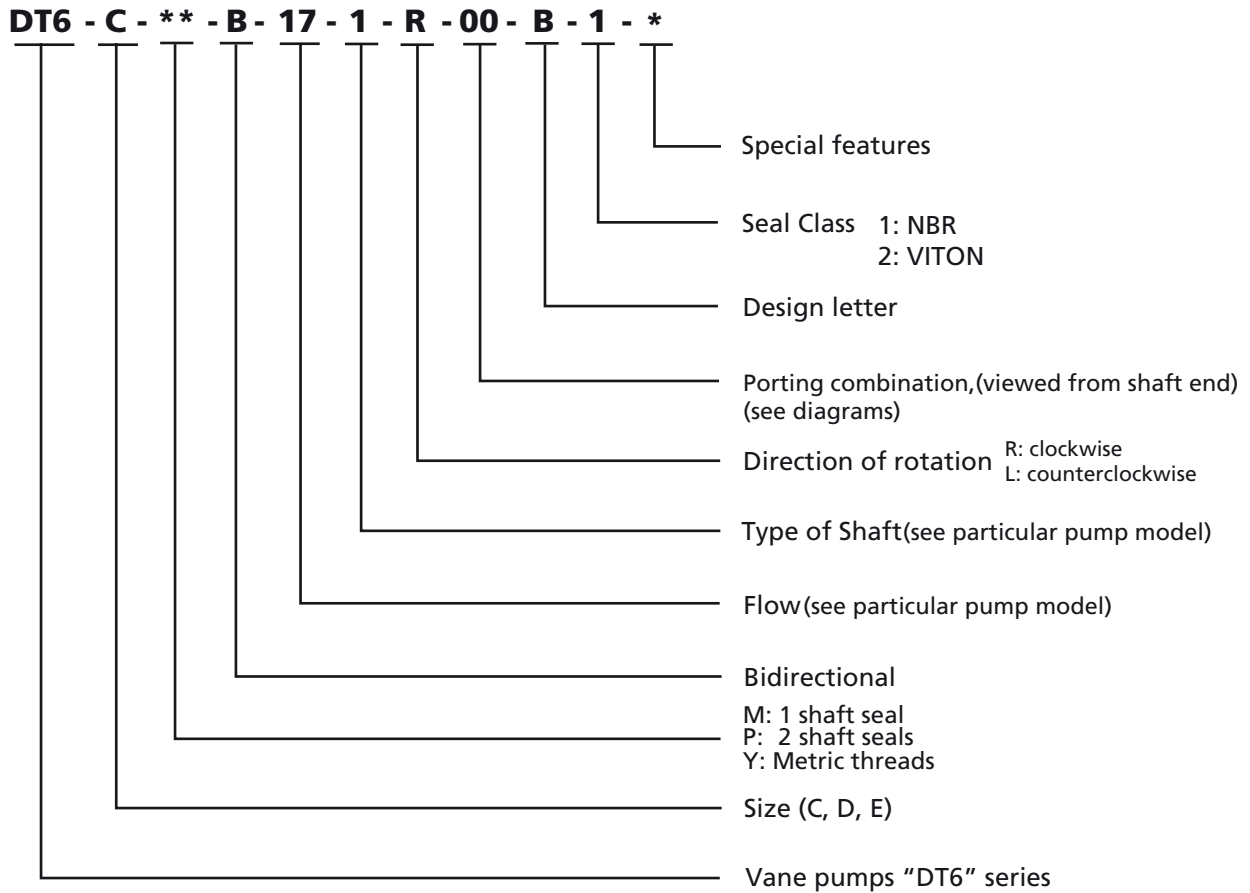



DT6 SINGLE VANE PUMPS - GENERAL CHARACTERISTICS

SINGLE PUMPS

| Pump Model | Cartridge Model | Theoretical displacement cm ³ /rev | Maximum Pressure | Max.speed rpm | Min. speed rpm | Weight Kgs | Front flange Standard SAE j744c ISO 3019-4 | SAE 4 holes flange | |
|---|-----------------|---|------------------|---------------|----------------|------------|--|--------------------|----------|
| | | | | | | | | Suction | Pressure |
| DT6C | 003 | 10.8 | 275 | 2800 | 500 | 15 | SAE B | 1.5" | 1" |
| | 005 | 17.2 | | | | | | | |
| | 006 | 21.3 | | | | | | | |
| | 008 | 26.4 | | | | | | | |
| | 010 | 34.1 | | | | | | | |
| | 012 | 37.1 | | | | | | | |
| | 014 | 46.0 | | | | | | | |
| | 017 | 58.3 | | | | | | | |
| | 020 | 63.8 | | | | | | | |
| | 022 | 70.3 | | | | | | | |
| | 025 | 79.3 | | | | | | | |
| | 028 | 88.8 | 210 | 2500 | | | | | |
| | 031 | 100 | | | | | | | |
| DT6CP Pump model only mount B14 to B31 cartridges | | | | | | | | | |
| DT6D | 014 | 47.6 | 240 | 2500 | 500 | 24 | SAE C | 2" | 1.25" |
| | 020 | 66.0 | | | | | | | |
| | 024 | 79.5 | | | | | | | |
| | 028 | 89.7 | | | | | | | |
| | 031 | 98.3 | | | | | | | |
| | 035 | 111.0 | | | | | | | |
| | 038 | 120.3 | | | | | | | |
| | 042 | 136.0 | | | | | | | |
| | 045 | 145.7 | | | | | | | |
| | 050 | 158.0 | | | | | | | |
| | 061 | 190.5 | | | | | | | |
| | | | 210 | 2200 | | | | | |
| | | | 120 | 1800 | | | | | |
| DT6E | 042 | 132.3 | 240 | 2200 | 500 | 44 | SAE C | 3" | 1.5" |
| | 045 | 142.4 | | | | | | | |
| | 050 | 158.5 | | | | | | | |
| | 052 | 164.8 | | | | | | | |
| | 062 | 196.7 | | | | | | | |
| | 066 | 213.3 | | | | | | | |
| | 072 | 227.1 | | | | | | | |
| | 085 | 269.8 | 90 | 2000 | | | | | |

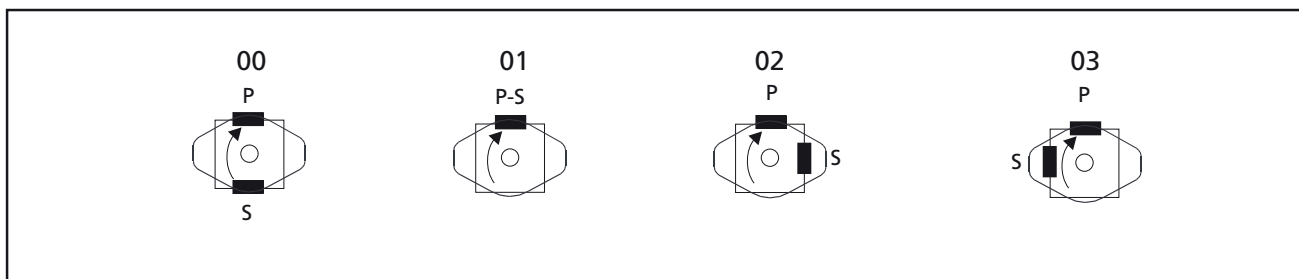

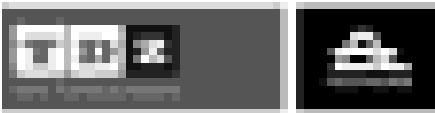

DT6C OPERATING CHARACTERISTICS

DATA SHEET

| FLOW | | | | | | | | | | SPEED (rpm) | | PRESSURE (bar) | | WEIGHT | | | |
|---------------------|----|----|----|----|----|----|----|----|----|-------------|------|----------------|---------|--------|-----|------|----|
| Lts/min.at 1000 rpm | | | | | | | | | | Min. | Máx. | Intermit. | Contin. | (Kgs.) | | | |
| 11 | 17 | 21 | 26 | 34 | 37 | 46 | 58 | 64 | 70 | 79 | 89 | 100 | 500 | 2800* | 275 | 240* | 15 |
| Gal/min.at 1200 rpm | | | | | | | | | | | | | | | | | |
| 3 | 5 | 6 | 8 | 10 | 12 | 14 | 17 | 20 | 22 | 25 | 28 | 31 | | | | | |

* See page 41 for further information about speed & pressure.

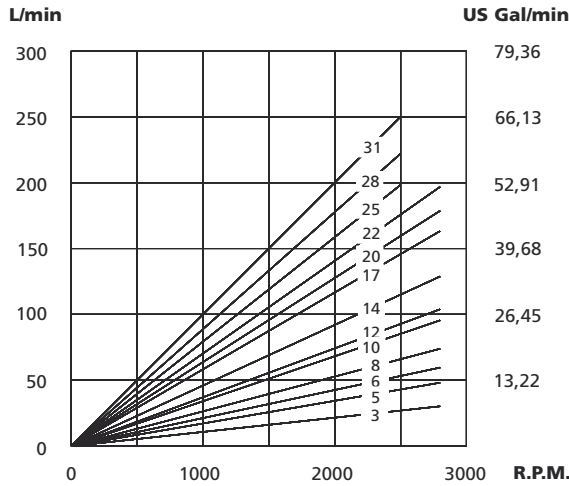

Theoretical Flow (0 Bar)

To calculate the real flow at a given operating pressure, subtract the internal leakage value for this pressure (see diagram below) from the theoretical flow. (See diagram above).

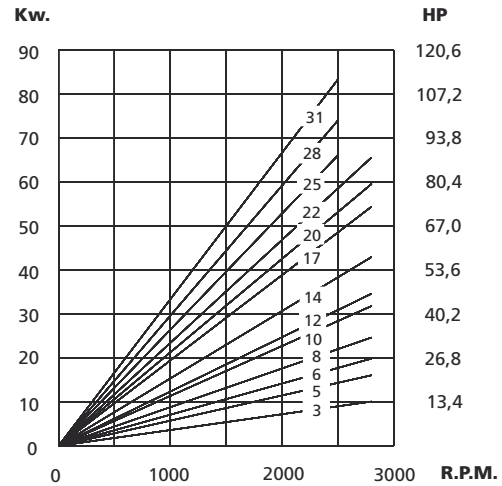

Theoretical Input Power at 200 Bar

To calculate the theoretical input power at other pressures and speeds, use the formula:

$$P(Kw) = \frac{Q(L/min.) \times P(Bar)}{600}$$

Where Q is the theoretical flow (upper left diagram) and P the operating pressure.

To calculate the real input power, add to the theoretical power the hydromechanical power losses (see diagram below).

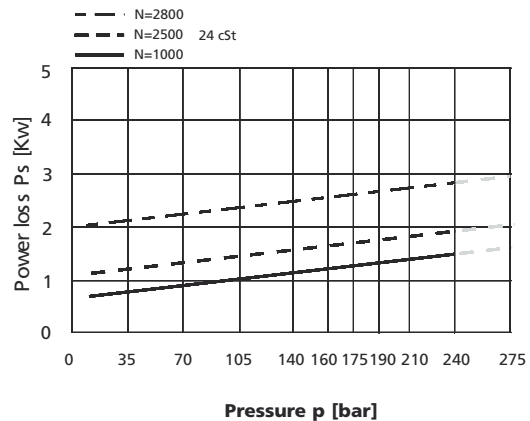
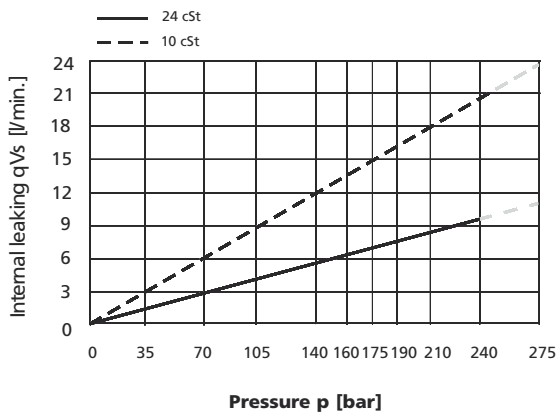

Do not operate pump more than 5 seconds at any speed or viscosity if internal leakage is more than 50 % of theoretical flow



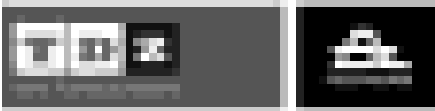

DIMENSIONS - SINGLE VANE PUMPS DT6C

DIMENSIONS IN MILLIMETERS. 1" = 25,4 mm

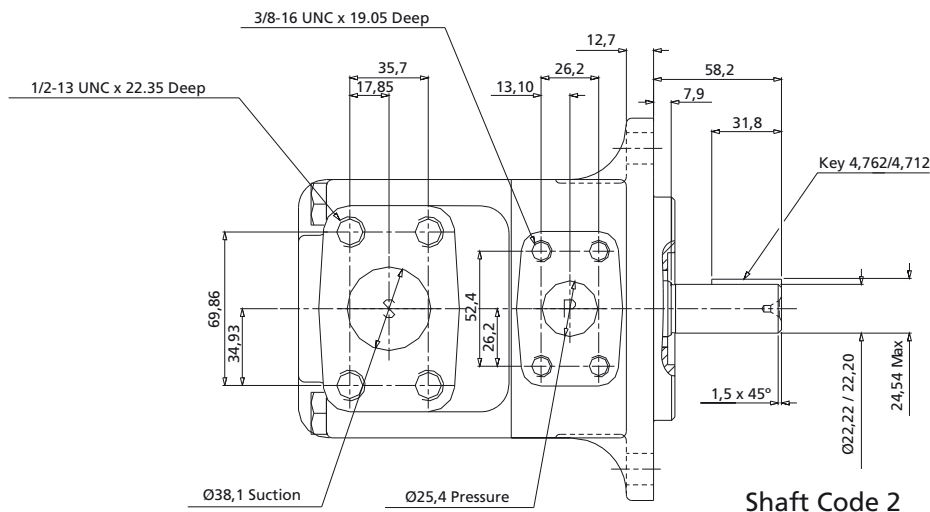
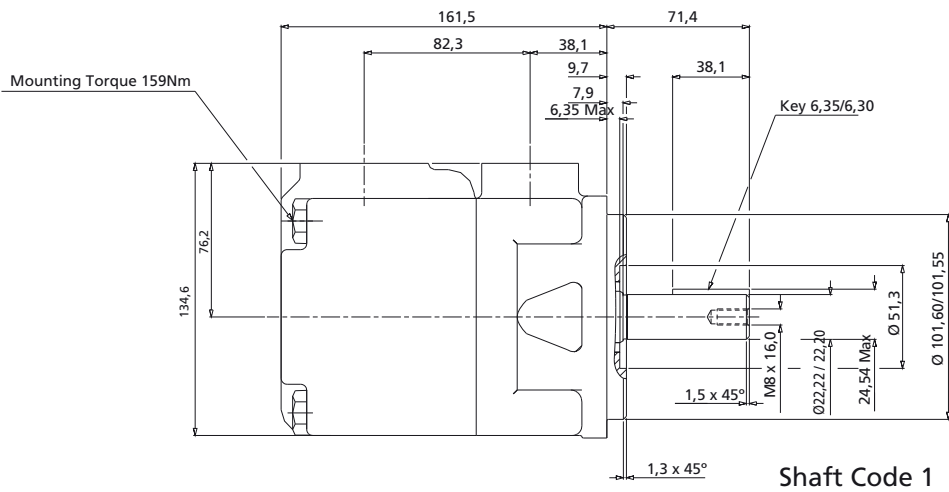
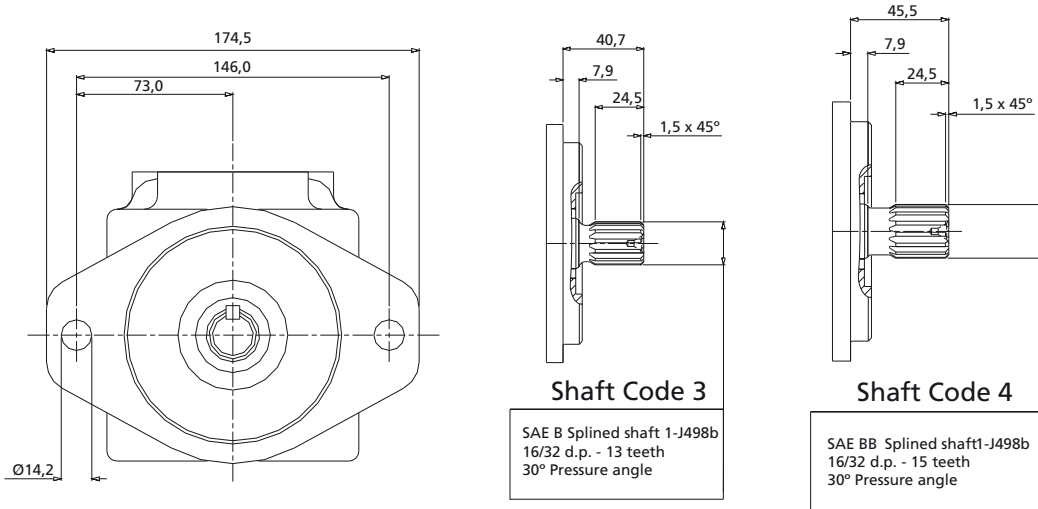

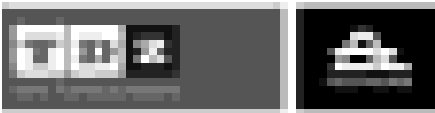

DT6D OPERATING CHARACTERISTICS

| FLOW | | | | | | | | | | | SPEED (rpm) | | PRESSURE (bar) | | WEIGHT |
|---------------------|----|----|----|----|-----|-----|-----|-----|-----|-----|-------------|-------|----------------|---------|--------|
| Lts/min.at 1000 rpm | | | | | | | | | | | Min. | Máx. | Intermit. | Contin. | (Kgs.) |
| 48 | 66 | 80 | 90 | 98 | 111 | 120 | 136 | 146 | 158 | 191 | 500 | 2500* | 240 | 210 | 24 |
| Gal/min.at 1200 rpm | | | | | | | | | | | 500 | 2500* | 240 | 210 | 24 |

* See page 41 for further information about speed & pressure.

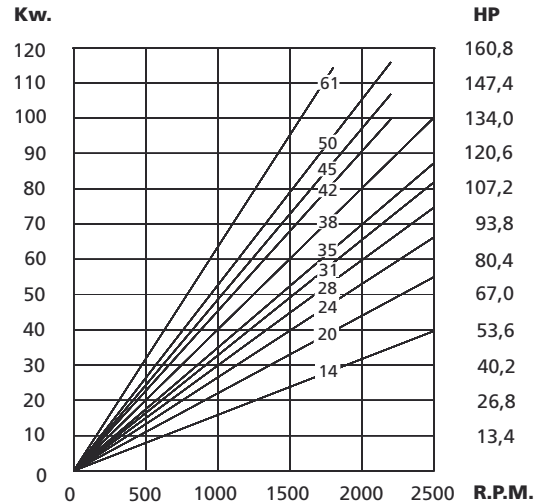
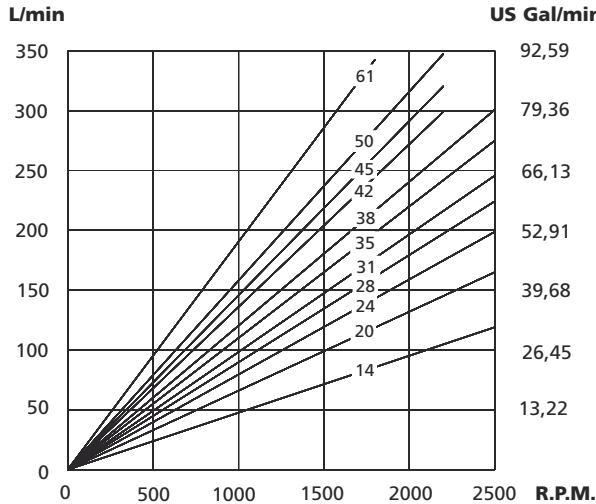

Theoretical Flow (0 Bar)

To calculate the real flow at a given operating pressure, subtract the internal leakage value for this pressure (see diagram below) from the theoretical flow. (See diagram above).

Theoretical Input Power at 200 Bar

To calculate the theoretical input power at other pressures and speeds, use the formula:

$$P(\text{Kw}) = \frac{Q(\text{L/min.}) \times P(\text{Bar})}{600}$$

Where Q is the theoretical flow (upper left diagram) and P the operating pressure.

To calculate the real input power, add to the theoretical power the hydromechanical power losses (see diagram below).

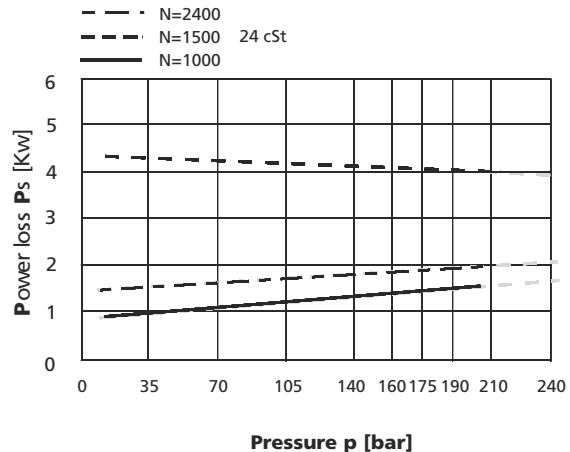
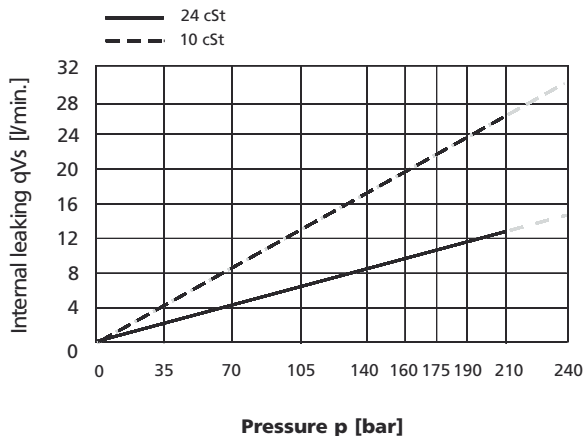



DIMENSIONS - SINGLE VANE PUMPS DT6D

DIMENSIONS IN MILLIMETERS. 1" = 25,4 mm

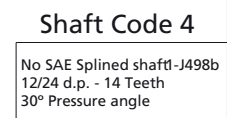
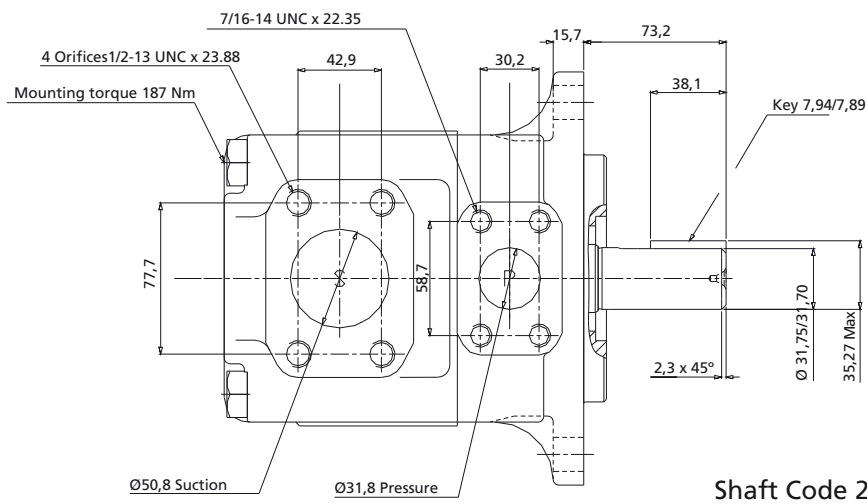
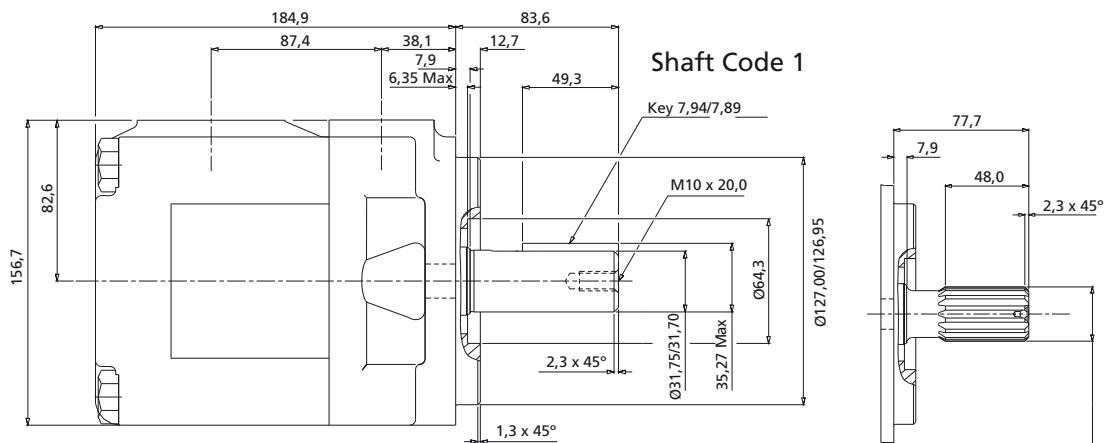
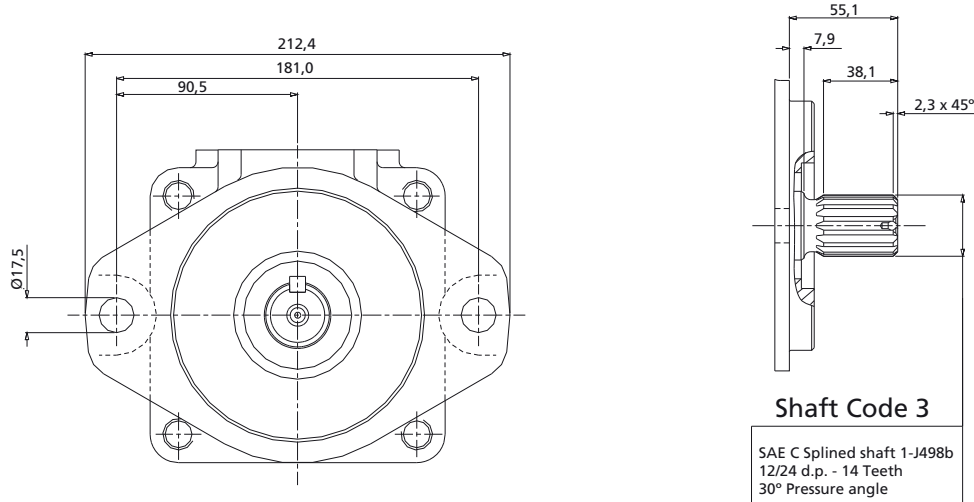

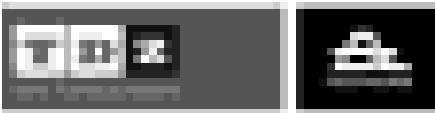

DT6E OPERATING CHARACTERISTICS

| | FLOW | | | | | | | SPEED (rpm) | | PRESSURE (bar) | | WEIGHT (Kgs.) |
|---------------------|---------------------|-----|-----|-----|-----|-----|-----|-------------|-------|----------------|----------|---------------|
| | Lts/min.at 1000 rpm | 132 | 142 | 156 | 197 | 213 | 227 | 270 | Mín. | Máx. | Intermit | |
| Gal/min.at 1200 rpm | 42 | 45 | 50 | 62 | 66 | 72 | 85 | 500 | 2200* | 240 | 210 | 44 |

* See page 41 for further information about speed & pressure.

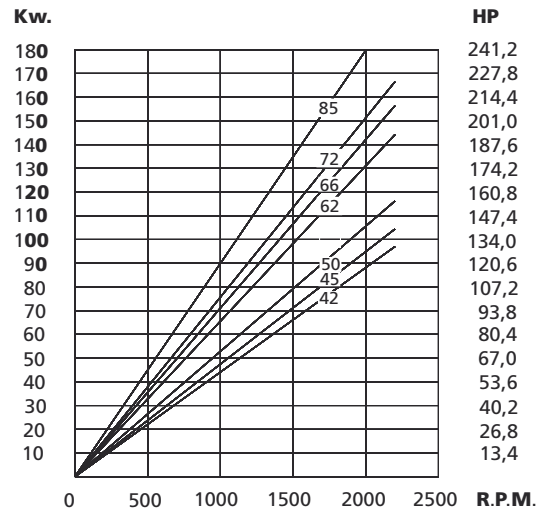
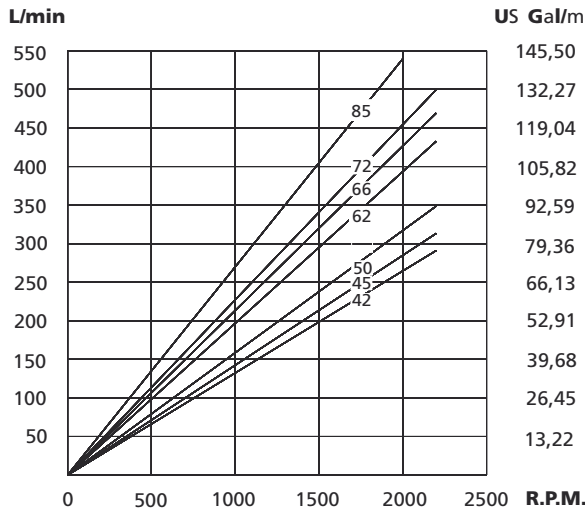

Theoretical Flow (0 Bar)

To calculate the real flow at a given operating pressure, subtract the internal leakage value for this pressure (see diagram below) from the theoretical flow. (See diagram above).

Theoretical Input Power at 200 Bar

To calculate the theoretical input power at other pressures and speeds, use the formula:

$$P(Kw) = \frac{Q(L/min.) \times P(Bar)}{600}$$

Where Q is the theoretical flow (upper left diagram) and P the operating pressure.

To calculate the real input power, add to the theoretical power the hydromechanical power losses (see diagram below).

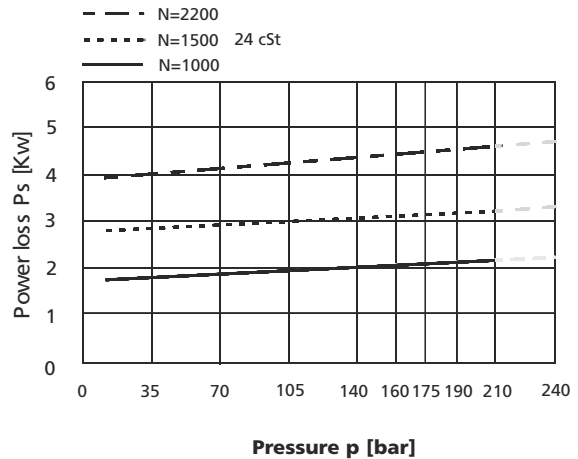
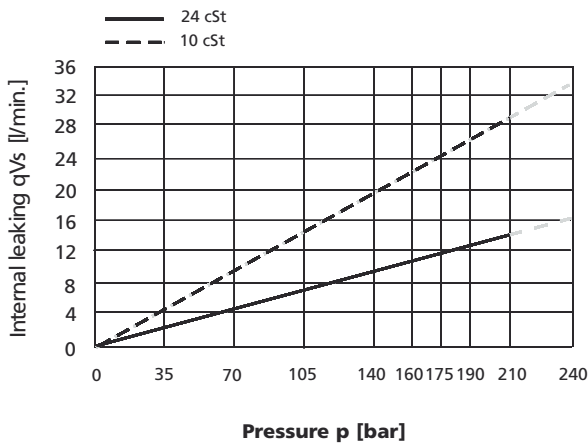



DIMENSIONS - SINGLE VANE PUMPS DT6E

DIMENSIONS IN MILLIMETERS. 1" = 25,4 mm

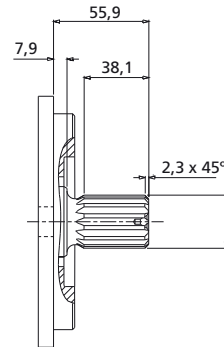
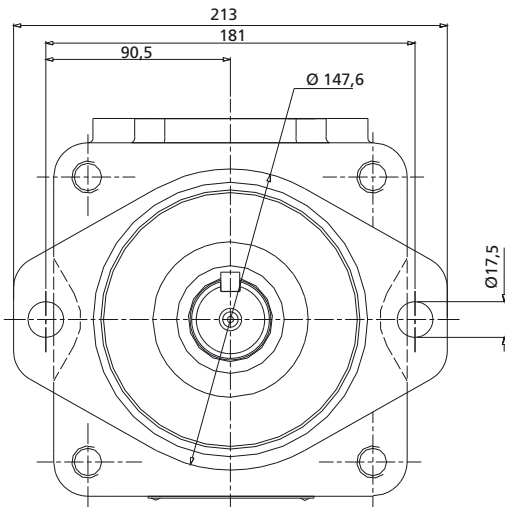

Shaft Code 3

SAE C Splined shaft 1-J498b
12/24 d.p. - 14 Teeth
30° Pressure angle

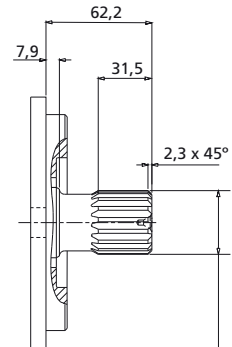

Shaft Code 4

SAE C-C Splined shaft
1-J498b 12/24 d.p. -
17 Teeth
30° Pressure angle

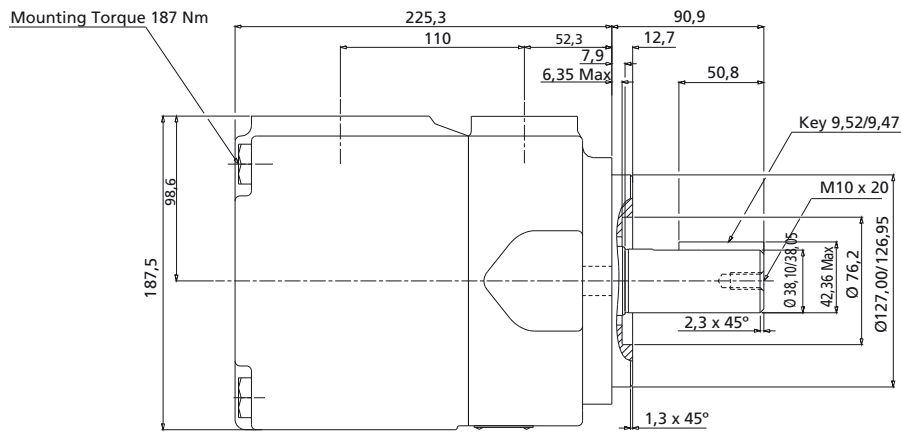

Shaft Code 1

SAE C-C

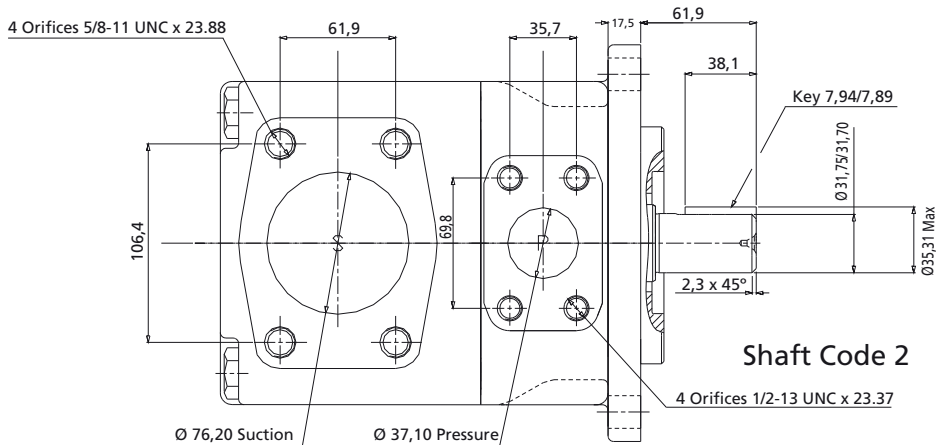

Shaft Code 2



THRU DRIVE VANE PUMPS

V**T thru drive single vane pumps

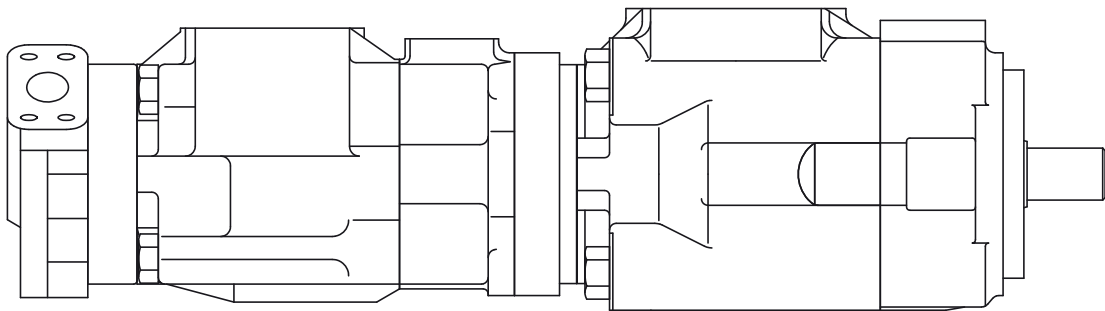

See single V* pumps for displacement & power diagrams (Pages 35, 37.39)

V*7TC thru drive pump with V*64 double pump



V* THRU DRIVE SINGLE VANE PUMPS ORDERING CODE

| | | | | | | | | |
|----|----|----|---|----|---|----|---|---|
| F3 | VS | 7T | C | 60 | D | 86 | A | A |
| 1 | 2 | 3 | 4 | 5 | 6 | 7 | 8 | 9 |

1 - "F3" means special seals for fire-resistant fluids. Omit if not required

2 - Pump Type:

VS = 12 vane pump, industrial use (very quiet), UNC threads

VQ = 10 vanes and bronze plates pump, mobile use, UNC threads

3 - Pump model: 4T, 6T and 7T.

4 - Rear pump mounting: With SAE mounting flange, 2-bolts.

A: SAE-A mounting flange

B: SAE-B mounting flange

C: SAE-C mounting flange

5 - Flow: In US Gallons per minute at 1200 rpm and 7 bar.

6 - D = Right-hand direction of rotation (Clockwise)

Y = Left-hand direction of rotation (Counterclockwise).

(To check the direction of rotation view from the shaft end).

7 - Shaft type:

1: Parallel keyed

11: Splined

86: Heavy duty parallel keyed

8 - Outlet position, (viewed from shaft):

A: In line with inlet

B: 90° on the right from inlet (Clockwise from inlet)

C: 180° from inlet

D: 90° on the left from inlet (Counterclockwise from inlet)

9- Rear flange positions, (viewed from the flange):

SAE A flanges

A: 45° on the right (Clockwise)

B: 45° on the left (Counterclockwise)

SAE-B and SAE-C flanges:

A: In line with in-front flange

B: 90° rotated





THRU DRIVE SINGLE VANE PUMPS CHARACTERISTICS

| TYPE | FLOW | | | SPEED (rpm) | | PRESSURE (Bar) | | Nominal Power (2) | CONNECTION | | WEIGHT (Kgs.) |
|--------------|-----------------|------------------|---------------|-------------|----------------------|----------------|-----------|---|------------|--------|---------------|
| | Lts.at 1000 rpm | Gal. At 1200 rpm | Reduction (1) | Min. | Max. | Contin. | Intermit. | | Inlet | Outlet | |
| VS4T VQ4T | 26 | 8 | 4,5 | 600 | 2500 1800 (VS) | 175 | 210 | 6,9 10,4 11,6 13,8 14,6 16,8 20,3 23,8 | Ø64 | Ø25,4 | 19,5 |
| | 40 | 12 | 5,7 | | | | | | | | |
| | 45 | 14 | 5,7 | | | | | | | | |
| | 55 | 17 | 5,8 | | | | | | | | |
| | 60 | 19 | 5,8 | | | | | | | | |
| | 67 | 21 | 6 | | | | | | | | |
| VS6T VQ6T | 66 | 21 | 8,6 | 600 | 2400 1800 (VS) | 175 | 210 | 16,8 20,3 24,3 27,4 29,3 33,3 | Ø76 | Ø31,8 | 29,5 |
| | 81 | 25 | 9 | | | | | | | | |
| | 97 | 30 | 10 | | | | | | | | |
| | 112 | 35 | 11,4 | | | | | | | | |
| | 121 | 38 | 11,4 | | | | | | | | |
| | 142 | 45 | 13,1 | | | | | | | | |
| VS7T VQ7T | 138 | 42 | 15 | 600 | 2200 1800 (VS) | 155 | 175 | 32,3 36,3 37,9 43,2 46,1 51,2 57,4 | Ø89 | Ø38,1 | 38 |
| | 148 | 47 | 15,7 | | | | | | | | |
| | 162 | 50 | 14,3 | | | | | | | | |
| | 180 | 57 | 17,9 | | | | | | | | |
| | 193 | 60 | 18,6 | | | | | | | | |
| | 214 | 67 | 22 | | | | | | | | |
| | 240 | 75 | 26 | | | | | | | | |

(1) Delivery flow reduction in Ltrs./min. at 100 Bar. 22 cST of oil viscosity at operating temperature. To calculate the approximate delivery flow at a given pressure and speed, use the following formula with flow reduction and theoretical flow values shown in the chart. Flow reduction values are independent of shaft speed.

$$\text{Approx. output flow (Ltrs./min.)} = \text{Theoretical flow} \times \frac{\text{R.P.M}}{1000} - \text{Reduction} \frac{\text{Pressure (bar)}}{100}$$

(2) Nominal power in H.P. at 100 Bar and 1000 RPM (to convert into Kw multiply by 0.735). To obtain the real input power at different pressure and revolutions, use the formula as follows:

$$\text{Real input power} = \text{Input power} \times \frac{\text{R.P.M}}{1000} \times \frac{\text{Pressure (bar)}}{100}$$

REAR PUMP MOUNTING

The mounted pump to the V**T* should have the shaft shown below:

| Model | Mounted pump shaft | | | |
|-------|--------------------|-------|-------------|--------|
| | DP splined | Teeth | Press angle | Flange |
| V**TA | 16/32 | 9 | 30° | SAE-A |
| V**TB | 16/32 | 13 | 30° | SAE-B |
| V**TC | 12/24 | 14 | 30° | SAE-C |

TRANSMISSIBLE MAXIMUM TORQUE

The torque of the V**T plus the torque of the rear pump, in pressure, shall be equal to or less than the below torques:

| V*4T | | V*6T | | V*7T | |
|-------|----------------|-------|----------------|-------|----------------|
| Shaft | Max. Torque Nm | Shaft | Max. Torque Nm | Shaft | Max. Torque Nm |
| 1 | 313 | 1 | 392 | 1 | 588 |
| 11 | 313 | 11 | 568 | 11 | 803 |
| 86 | 392 | 86 | 588 | 86 | 803 |

MAXIMUM TORQUE OF THE MOUNTED REAR PUMP

The torque of the mounted pump to the V**T rear pump, in pressure, shall be equal to or less than the indicated torques on next page.

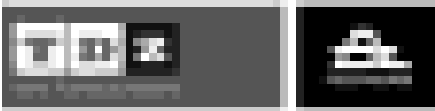

REAR FLANGE MOUNTING OF THE V**T* THRU DRIVE PUMP DIMENSIONS

DATA SHEET

DIMENSIONS IN MILLIMETERS 1" = 25.4 mm

| Rear Flange (connection) | Max Torque Nm |
|--------------------------|----------------------------|
| A | 130 |
| B | 315 |
| C | 440 (V*6TC) 700 (V*7TC) |

V*4TA, V*6TA & V*7TA

Torque for screw 65 Nm.

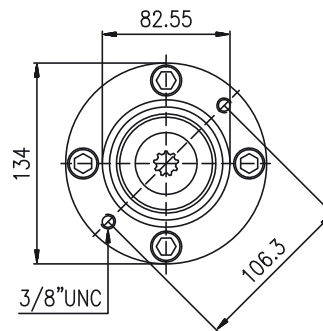

V*4TB, V*6TB & V*7TB

Torque for screw 65 Nm.

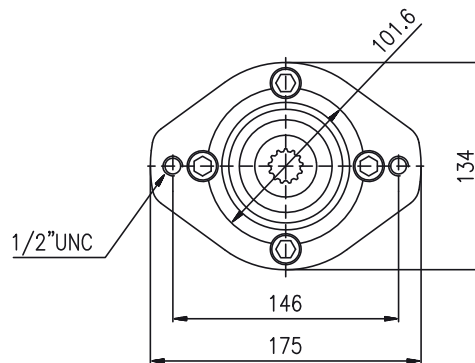

V*6TC & V*7TC

Torque for screw 65 Nm.

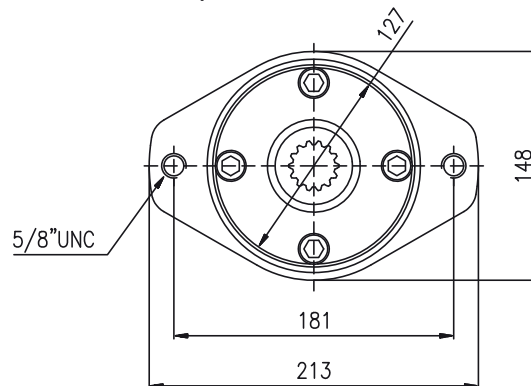



THRU DRIVE SINGLE VANE PUMPS

THRU DRIVE PUMPS VS4T & VQ4T

DIMENSIONS IN MILLIMETERS 1" = 25.4 mm

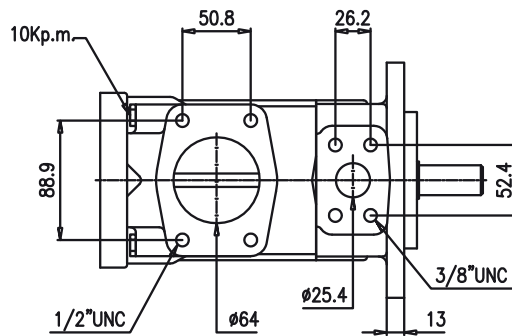
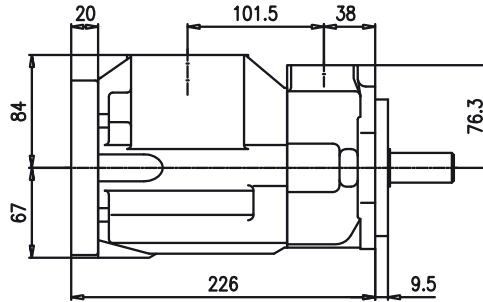
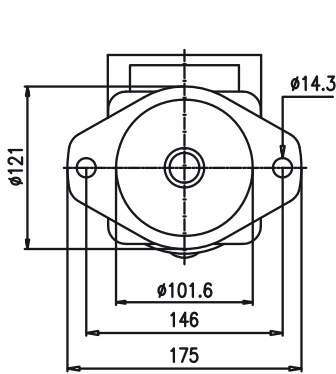
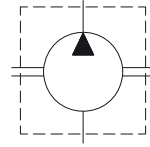

N°1 Shaft

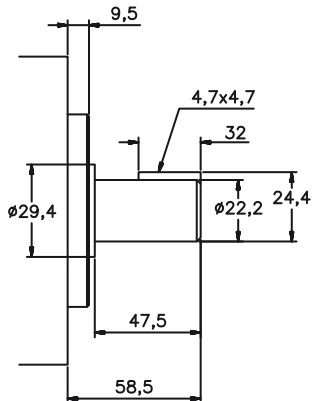

N°11 Shaft

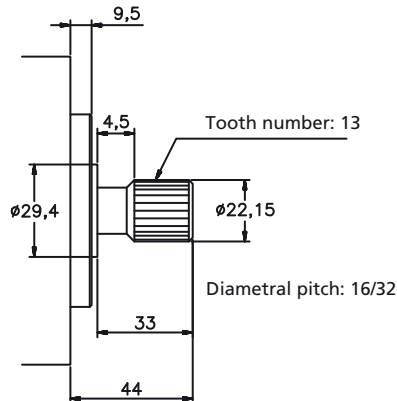

N°86 Shaft

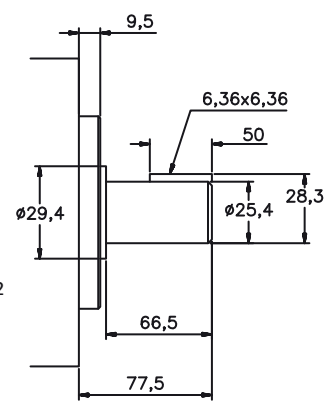

Enquire about other types of shafts

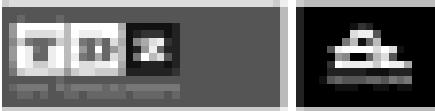

THRU DRIVE SINGLE VANE PUMPS

THRU DRIVE PUMPS VS6T & VQ6T

DATA SHEET

DIMENSIONS IN MILLIMETERS 1" = 25.4 mm

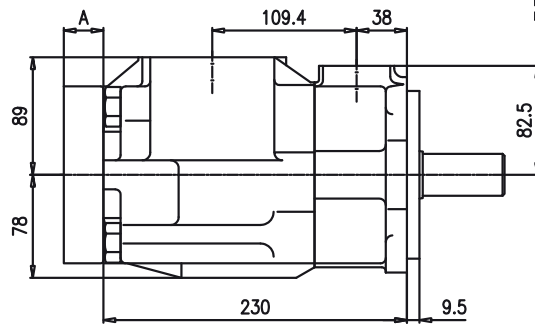
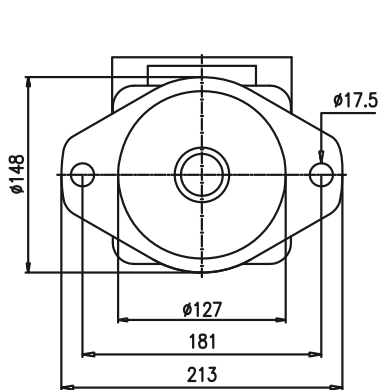
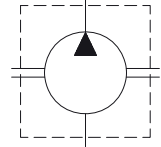

| Model | A |
|-------|----|
| V*6TA | 20 |
| V*6TB | 30 |
| V*6TC | 38 |

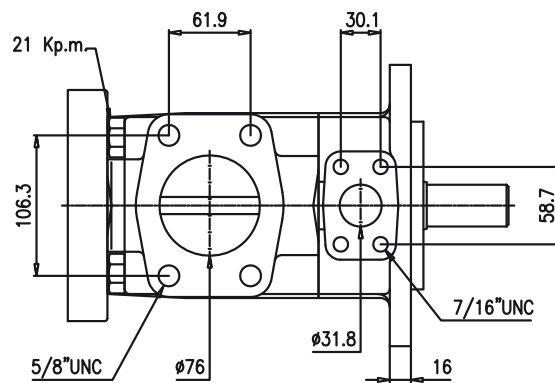

N°1 Shaft

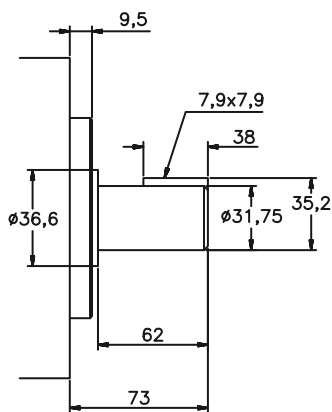

N°11 Shaft

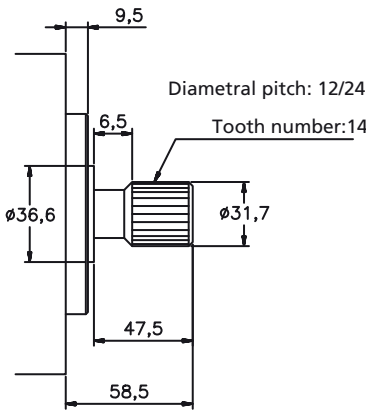

N°86 Shaft

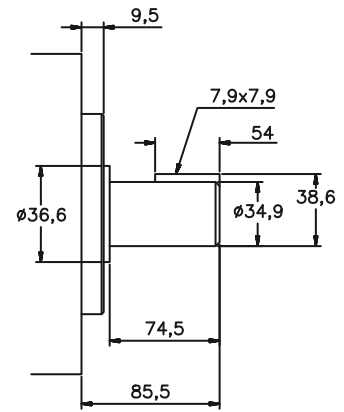

Enquire about other types of shafts





THRU DRIVE SINGLE VANE PUMPS

THRU DRIVE PUMPS VS7T & VQ7T

DIMENSIONS IN MILLIMETERS 1" = 25.4 mm

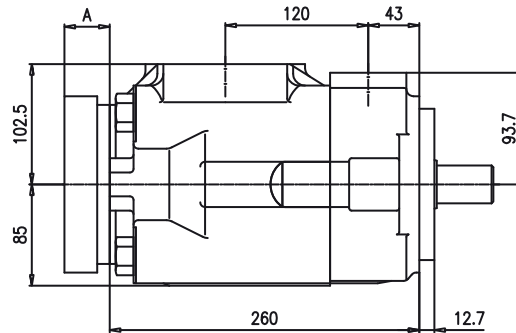
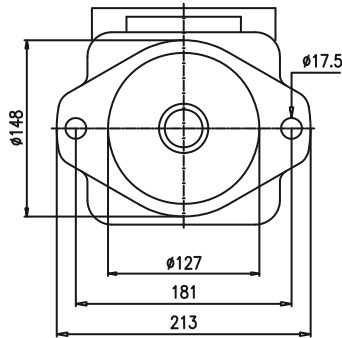
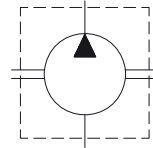

| Model | A |
|-------|----|
| V*7TA | 20 |
| V*7TB | 30 |
| V*7TC | 38 |

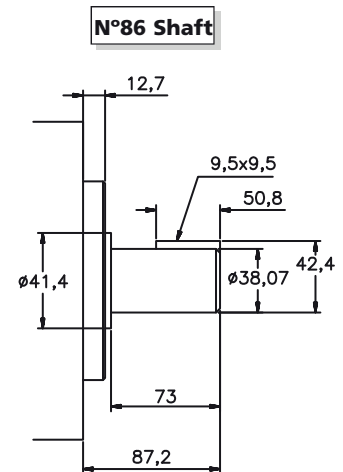
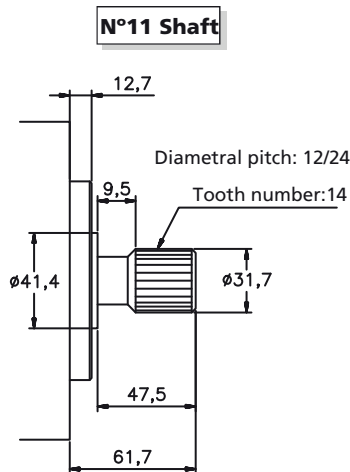
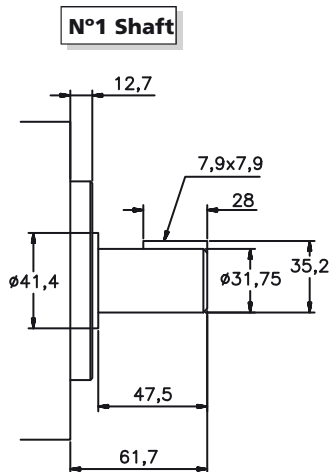
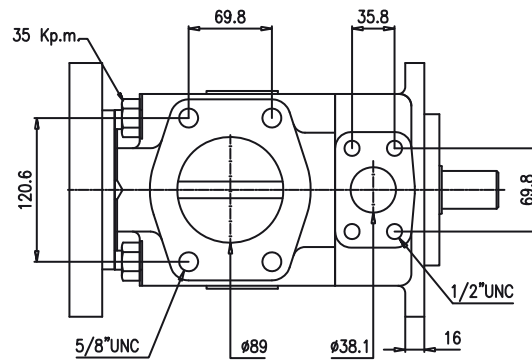

Enquire about other types of shafts



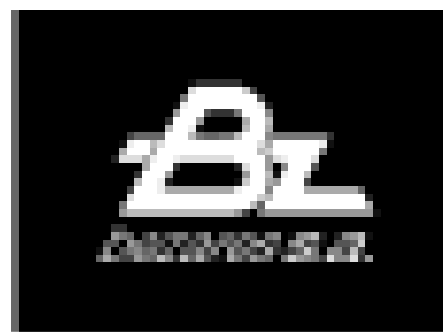

DOUBLE VANE PUMPS

VQ, VS and DT6 Double vane pumps

(See single pumps for displacement & power diagrams)

Pages 35, 37 and 39 for VQ & VS

Pages 42,44 and 46 for DT6

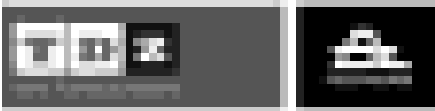

V* DOUBLE VANE PUMPS ORDERING CODE

F3 VS 43 21 8 D 1 A A
1 2 3 4 5 6 7 8 9

1 - "F3" means special seals for fire-resistant fluids. Omit if not required

2 - Pump Type:

VC = 12 vane pump, medium pressure application.

VS = 12 vane pump, (except the cover end cartridge of the VS*3 pump), industrial uses (very quiet), UNC threads.

VQ = 10 vane pump, bronze plates, mobile uses, UNC threads.

3 - Model of pump: 2010,2020,43,63,64,73,74 and 76.

4 - Pump flow at shaft side: All models in US gallons per minute at 1200 rpm and 7 Bar.
(See flow chart).

5 - Pump flow at cover side: All models in gallons per minute at 1200 rpm and 7 Bar.
(See flow chart).

6 - D = Right-hand rotation (Clockwise)
Y = Left-hand rotation (Counterclockwise).
(Viewed from the shaft end).

7 - Shaft type:

1: Parallel keyed

11: Splined

86: Heavy duty parallel keyed

8 - Shaft end outlet position, (viewed from shaft):

A: Outlet in line with inlet

B: 90° clockwise from inlet

C: 180° from inlet

D: 90° counterclockwise from inlet (Viewed from shaft)

9- Cover end outlet position, (viewed from shaft):

A: 45° clockwise from inlet

B: 135° clockwise from inlet

C: 135° counterclockwise from inlet

D: 45° counterclockwise from inlet

(Viewed from shaft)

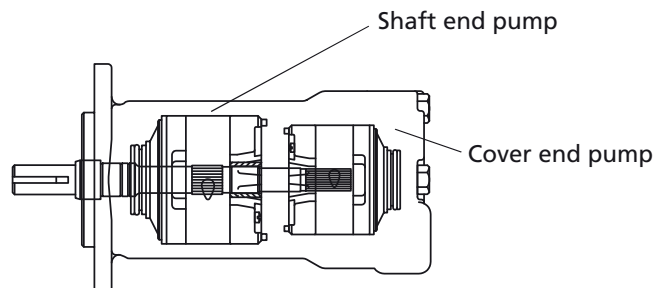



V* DOUBLE VANE PUMP CHARACTERISTICS

| TYPE | SHAFT END | | | | | | COVER END | | | | | | WEIGHT (Kgs.) | | | |
|--------------|----------------|------------------|-------------|----------|----------------|---------|-------------------|----------------|-----------------|-------------|----------|----------------|---------------|-------------------|---------|------|
| | FLOW | | | MAX. rpm | PRESSURE (Bar) | | Nominal Power (2) | FLOW | | | MAX. rpm | PRESSURE (Bar) | | Nominal Power (2) | | |
| | Lts.at 1000rpm | Gal. At 1200 rpm | Reducc. (1) | | Contin. | Intern. | | Lts.a 1000 rpm | Gal. a 1200 rpm | Reducc. (1) | | Contin. | | | Intern. | |
| | | | | | | | | | | | | | | | | |
| VC2010 | 16 | 5 | 2 | 3400 | | 180 | 3,2 | | | | | | | | | |
| | 20 | 6 | 2,8 | | | | 3,9 | 3 | 1 | 0,8 | | | | | | 0,7 |
| | 23 | 7 | 4 | 3000 | 155 | 180 | 4,4 | 7 | 2 | 0,9 | | | | 1,4 | | |
| | 27 | 8 | 4,2 | 2800 | | | 5,1 | 10 | 3 | 1,2 | | | | | 2,1 | |
| | 30 | 9 | 4,5 | 2500 | 155 | 180 | 5,6 | 13 | 4 | 1,6 | 3000 | 155 | 180 | 2,7 | | |
| | 34 | 10 | 4,8 | | | | 6,1 | 16 | 5 | 1,7 | | | | | | |
| | 36 | 11 | 4,8 | 2400 | 155 | 180 | 6,5 | 20 | 6 | 1,8 | 2400 | 140 | | 3,7 | | |
| | 39 | 12 | 5,4 | | | | 7,5 | 23 | 7 | 1,9 | | | | | | |
| 42 | 13 | 6,0 | 140 | | | 8,1 | | | | | | | | | | |
| VC2020 | 16 | 5 | 2 | 3400 | | 180 | 3,2 | | | | | | | | | |
| | 20 | 6 | 2,8 | | | | 3,9 | 16 | 5 | 2 | | | | | | 3,2 |
| | 23 | 7 | 4 | 3000 | 155 | 180 | 4,4 | 20 | 6 | 2,8 | 3400 | 155 | 180 | 3,9 | | |
| | 27 | 8 | 4,2 | 2800 | | | 5,1 | 23 | 7 | 4 | | | | | | |
| | 30 | 9 | 4,5 | 2500 | 155 | 180 | 5,6 | 27 | 8 | 4,2 | 3000 | 155 | 180 | 5,1 | | |
| | 34 | 10 | 4,8 | | | | 6,1 | 30 | 9 | 4,5 | | | | | | |
| | 36 | 11 | 4,8 | 2400 | 155 | 180 | 6,5 | 34 | 10 | 4,8 | 2500 | 155 | 180 | 6,1 | | |
| | 39 | 12 | 5,4 | | | | 7,5 | 36 | 11 | 4,8 | | | | | | |
| 42 | 13 | 6,0 | 140 | | | 8,1 | 39 | 12 | 5,4 | 2400 | 140 | | 7,5 | | | |
| | | | | | | | 42 | 13 | 6,0 | | | | 8,1 | | | |
| VS43 VQ43 | 26 | 8 | 4,5 | 2500 | 175 | 210 | 6,9 | | | | | | | | | |
| | 40 | 12 | 5,7 | | | | 10,4 | 8 | 2 | 0,9 | | | | | | 1,9 |
| | 45 | 14 | 5,7 | 1800 | 175 | 210 | 11,6 | 18 | 5 | 2,1 | 2500 | 175 | 210 | 4 | | |
| | 55 | 17 | 5,8 | (VS) | | | 13,8 | 27 | 8 | 2,8 | | | | | | |
| | 60 | 19 | 5,8 | 1500 | 125 | 150 | 15,2 | 29 | 9 | 3,5 | 1500 | 125 | 150 | 6,9 | | |
| | 67 | 21 | 6 | | | | 16,8 | 36 | 11 | 4,3 | | | | | | |
| | 80 | 24 | 6,2 | 1500 | 125 | 150 | 20,3 | 39 | 12 | 4,3 | 1500 | 125 | 150 | 7,4 | | |
| | 88* | 27 | 6,5 | | | | 22,4 | 46 | 14 | 4,3 | | | | | | |
| VS63 VQ63 | 66 | 21 | 8,6 | 2400 | 175 | 210 | 16,8 | | | | | | | | | |
| | 81 | 25 | 9 | | | | 20,3 | 8 | 2 | 0,9 | | | | | | 1,9 |
| | 97 | 30 | 10 | 1800 | 175 | 210 | 24,3 | 18 | 5 | 2,1 | 2400 | 175 | 210 | 4 | | |
| | 112 | 35 | 11,4 | (VS) | | | 27,4 | 27 | 8 | 2,8 | | | | | | |
| | 121 | 38 | 11,4 | 1500 | 125 | 150 | 29,3 | 29 | 9 | 3,5 | 1500 | 125 | 150 | 6,9 | | |
| | 142 | 45 | 13,1 | | | | 33,3 | 36 | 11 | 4,3 | | | | | | |
| | | | | 1500 | 125 | 150 | 33,3 | 39 | 12 | 4,3 | 1500 | 125 | 150 | 7,4 | | |
| | | | | | | | 46 | 14 | 4,3 | | | | | | | |
| VS64 VQ64 | 66 | 21 | 8,6 | 2400 | 175 | 210 | 16,8 | | | | | | | | | |
| | 81 | 25 | 9 | | | | 20,3 | 8 | 2 | 0,9 | | | | | | 1,9 |
| | 97 | 30 | 10 | 1800 | 175 | 210 | 24,3 | 12 | 5,7 | | 2500 | 175 | 210 | 4 | | |
| | 112 | 35 | 11,4 | (VS) | | | 27,4 | 14 | 5,7 | | | | | | | |
| | 121 | 38 | 11,4 | 1500 | 125 | 150 | 29,3 | 17 | 5,8 | | 1800 | 1800 | (VS) | 11,6 | | |
| | 142 | 45 | 13,1 | | | | 33,3 | 19 | 5,8 | | | | | | | |
| | | | | 1500 | 125 | 150 | 33,3 | 21 | 6 | | 1500 | 125 | 150 | 15,2 | | |
| | | | | | | | 80 | 24 | 6,2 | | | | | | | |
| | | | | | | 88* | 27 | 6,5 | | | | | 20,3 | | | |
| | | | | | | | | | | | | | 22,4 | | | |
| VS73 VQ73 | 138 | 42 | 15 | 2200 | 155 | 175 | 32,3 | | | | | | | | | |
| | 148 | 47 | 15,7 | | | | 36,3 | 8 | 2 | 0,9 | | | | | | 1,9 |
| | 162 | 50 | 14,3 | 1800 | 155 | 175 | 37,9 | 18 | 5 | 2,1 | 2500 | 175 | 210 | 4 | | |
| | 180 | 57 | 17,9 | (VS) | | | 43,2 | 27 | 8 | 2,8 | | | | | | |
| | 193 | 60 | 18,6 | 1500 | 125 | 150 | 46,1 | 29 | 9 | 3,5 | 1800 | 1800 | (VS) | 6,9 | | |
| | 214 | 67 | 22 | | | | 51,2 | 36 | 11 | 4,3 | | | | | | |
| | 240 | 75 | 26 | 57,4 | 39 | 12 | 4,3 | | | | | | 7,4 | | | |
| | | | | | | | 57,4 | 46 | 14 | 4,3 | | | | 7,6 | | |
| VS74 VQ74 | 138 | 42 | 15 | 2200 | 155 | 175 | 32,3 | | | | | | | | | |
| | 148 | 47 | 15,7 | | | | 36,3 | 8 | 2 | 0,9 | | | | | | 1,9 |
| | 162 | 50 | 14,3 | 1800 | 155 | 175 | 37,9 | 12 | 5,7 | | 2500 | 175 | 210 | 4 | | |
| | 180 | 57 | 17,9 | (VS) | | | 43,2 | 14 | 5,7 | | | | | | | |
| | 193 | 60 | 18,6 | 1500 | 125 | 150 | 46,1 | 17 | 5,8 | | 1800 | 1800 | (VS) | 11,6 | | |
| | 214 | 67 | 22 | | | | 51,2 | 19 | 5,8 | | | | | | | |
| | 240 | 75 | 26 | 57,4 | 21 | 6 | | | | | | | 16,8 | | | |
| | | | | | | | 80 | 24 | 6,2 | | | | | 20,3 | | |
| | | | | | | 88* | 27 | 6,5 | | | | | 22,4 | | | |
| VS76 VQ76 | 138 | 42 | 15 | 2200 | 155 | 175 | 32,3 | | | | | | | | | |
| | 148 | 47 | 15,7 | | | | 36,3 | 21 | 8,6 | | | | | | | 16,8 |
| | 162 | 50 | 14,3 | 1800 | 155 | 175 | 37,9 | 25 | 9 | | 2400 | 175 | 210 | 4 | | |
| | 180 | 57 | 17,9 | (VS) | | | 43,2 | 30 | 10 | | | | | | | |
| | 193 | 60 | 18,6 | 1500 | 125 | 150 | 46,1 | 35 | 11,4 | | 1800 | 1800 | (VS) | 11,6 | | |
| | 214 | 67 | 22 | | | | 51,2 | 38 | 11,4 | | | | | | | |
| | 240 | 75 | 26 | 57,4 | 45 | 13,1 | | | | | | | 16,8 | | | |
| | | | | | | | 88* | 42 | 13,1 | | | | | 20,3 | | |
| | | | | | | | | | | | | | 24,3 | | | |
| | | | | | | | | | | | | | 27,4 | | | |
| | | | | | | | | | | | | | 29,3 | | | |
| | | | | | | | | | | | | | 33,3 | | | |

* 27 gallons (88lts.) cartridge not mounted in VQ 42, VQ 43, VQ 64, VQ 74 vane pump model.
(1), (2) & (3) Please turn to next page

(1) Delivery flow reduction in Ltrs./min. at 100 Bar. 22 cST of oil viscosity at operating temperature. To calculate the approximate delivery flow at a given pressure and speed, use the following formula with flow reduction and theoretical flow values shown in the chart. Flow reduction values are independent of shaft speed.

$$\text{Approx. output flow (Ltrs./min.)} = \text{Theoretical flow} \times \frac{\text{R.P.M}}{1000} - \text{Reduction} \times \frac{\text{Pressure (Bar)}}{1000}$$

(2) Nominal Power in H.P. at 100 Bar and 1000 RPM (to convert into Kw multiply by 0.735).

To obtain the real input power at different pressure and revolutions, use the formula as follows:

$$\text{Real input power} = \text{Input power} \times \frac{\text{R.P.M}}{1000} \times \frac{\text{Pressure (Bar)}}{1000}$$

(3) See options on dimension pages.



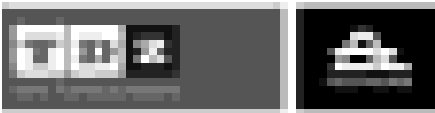

V* DOUBLE VANE PUMPS

DOUBLE VANE PUMPS VC2010

DATA SHEET

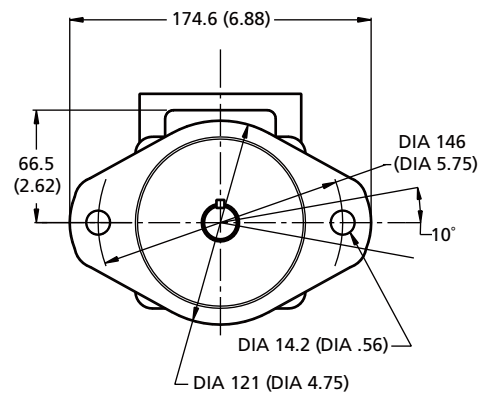
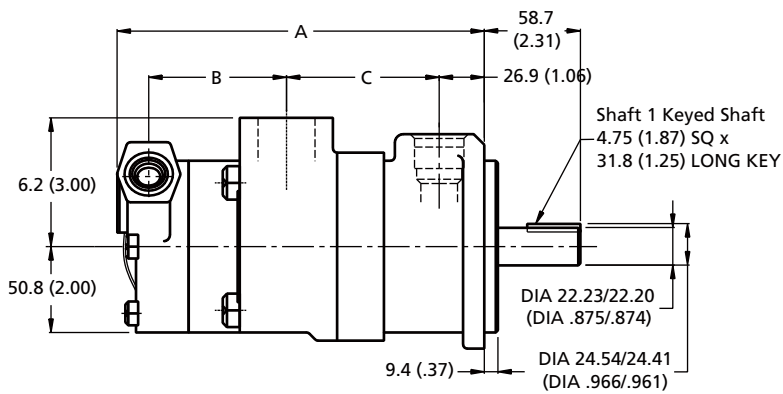
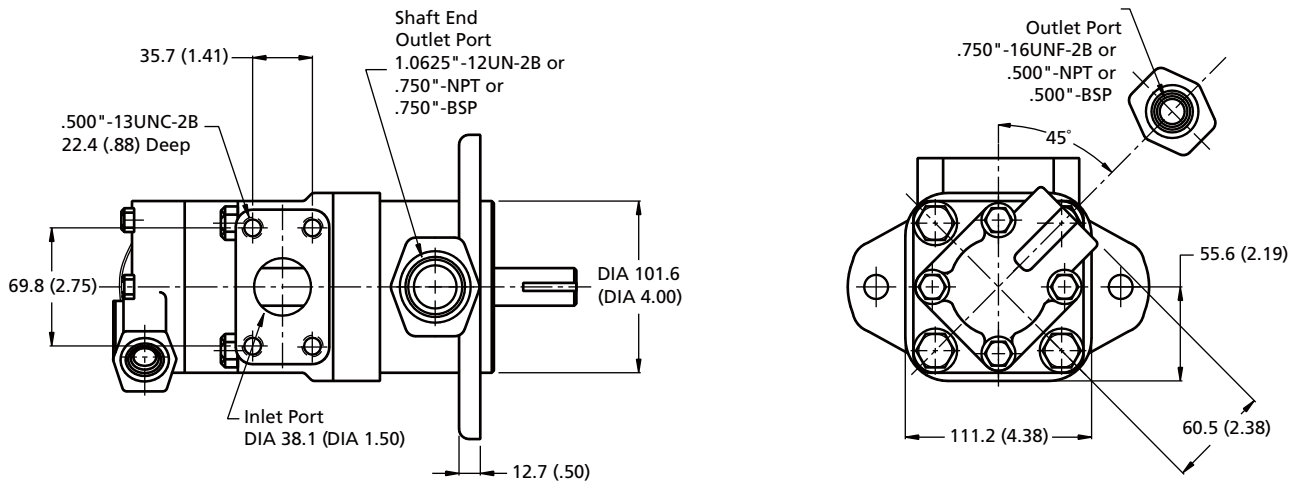

N°1 Shaft

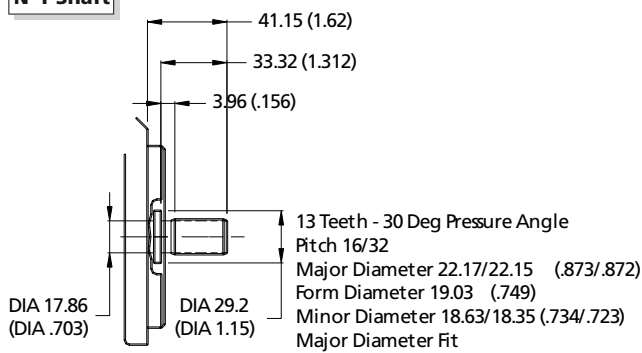

**Shaft 11
Splined Shaft**

| Delivery @ 1200 rpm & 7 bar (100 psi) | | Dimension | | |
|---------------------------------------|-----------|--------------|-------------|-------------|
| Shaft End | Cover End | A | B | C |
| 7, 8, 9 | 1, 2, 3 | 213.1 (8.39) | 75.9 (2.99) | 86.4 (3.40) |
| 7, 8, 9 | 4, 5 | 219.5 (8.64) | 82.3 (3.24) | 86.4 (3.40) |
| 7, 8, 9 | 6, 7 | 224.5 (8.84) | 87.4 (3.44) | 86.4 (3.40) |
| 10, 11 | 1, 2, 3 | 218.2 (8.59) | 75.9 (2.99) | 91.2 (3.59) |
| 10, 11 | 4, 5 | 224.5 (8.84) | 82.3 (3.24) | 91.2 (3.59) |
| 10, 11 | 6, 7 | 229.6 (9.04) | 87.4 (3.44) | 91.2 (3.59) |
| 12, 13 | 1, 2, 3 | 221.7 (8.73) | 75.9 (2.99) | 94.7 (3.73) |
| 12, 13 | 4, 5 | 227.8 (8.97) | 82.3 (3.24) | 94.7 (3.73) |
| 12, 13 | 6, 7 | 232.9 (9.17) | 87.4 (3.44) | 94.7 (3.73) |





DOUBLE VANE PUMPS VC2020

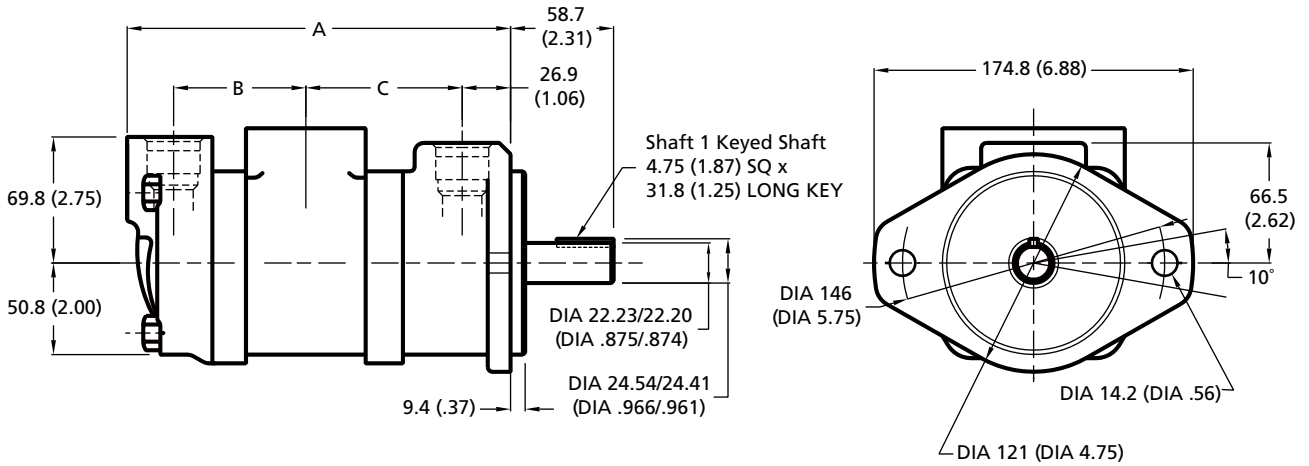
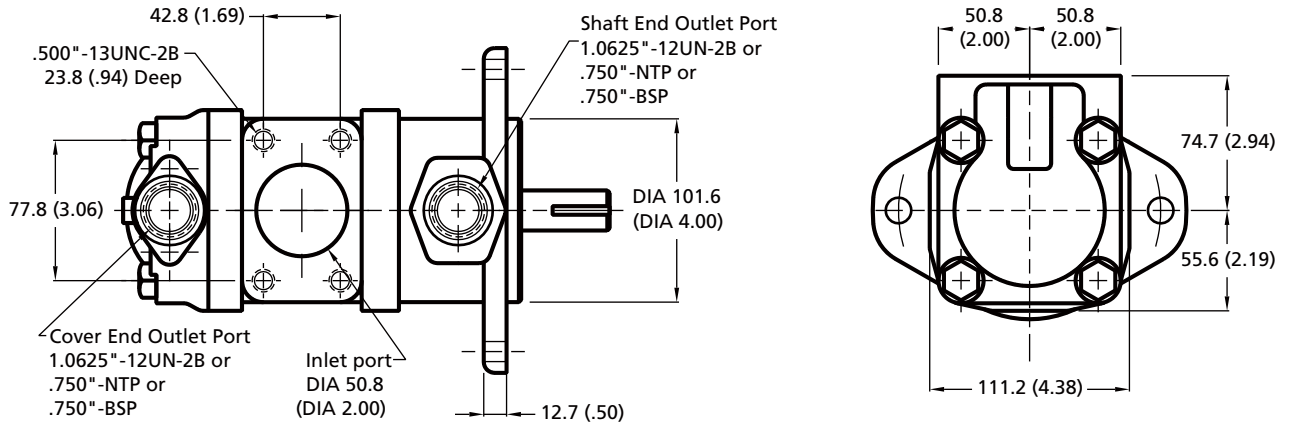

N°1 Shaft

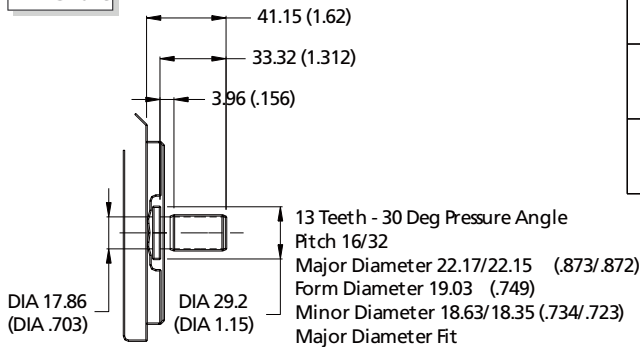

**Shaft 11
Splined Shaft**

| Delivery @ 1200 rpm & 7 bar (100 psi) | | Dimension | | |
|---------------------------------------|-----------|--------------|-------------|-------------|
| Shaft End | Cover End | A | B | C |
| 7, 8, 9 | 5, 6 | 213.6 (8.41) | 73.7 (2.90) | 87.1 (3.43) |
| 7, 8, 9 | 7, 8, 9 | 220.0 (8.66) | 80.0 (3.15) | 87.1 (3.43) |
| 10, 11 | 5, 6 | 218.7 (8.61) | 73.7 (2.90) | 92.2 (3.63) |
| 10, 11 | 7, 8, 9 | 225.0 (8.86) | 80.0 (3.15) | 92.2 (3.63) |
| 10, 11 | 10, 11 | 229.9 (9.05) | 85.1 (3.35) | 92.2 (3.63) |
| 12, 13 | 5, 6 | 222.3 (8.75) | 73.7 (2.90) | 95.5 (3.76) |
| 12, 13 | 7, 8, 9 | 228.3 (8.99) | 80.0 (3.15) | 95.5 (3.76) |
| 12, 13 | 11 | 233.4 (9.19) | 85.1 (3.35) | 95.5 (3.76) |

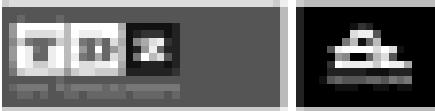

V* DOUBLE VANE PUMPS

DOUBLE VANE PUMPS VS-43 Y VQ-43

DATA SHEET

| SHAFT END FLOW | | | | | | | | SPEED (rpm) | | PRES (BAR) | | CONNECTION | | |
|-----------------|----|----|----|----|----|----|-----|-------------|------|------------|---------|------------|-------|--------|
| Lts.at 1000 rpm | 26 | 40 | 45 | 55 | 60 | 67 | 80* | 88* | Min. | Max. | Contin. | Intermit. | Inlet | Outlet |
| Gal.at 1200 rpm | 8 | 12 | 14 | 17 | 19 | 21 | 24* | 27* | 600 | 2500* | 175 | 210* | Ø2.5" | Ø1" |

| COVER END FLOW | | | | | | | SPEED (rpm) | | PRES (BAR) | | CONNECTION | | |
|-----------------|---|----|----|----|----|----|-------------|------|------------|---------|------------|-------|--------|
| Lts.at 1000 rpm | 8 | 18 | 27 | 29 | 36 | 39 | 46 | Min. | Max. | Contin. | Intermit. | Inlet | Outlet |
| Gal.at 1200 rpm | 2 | 5 | 8 | 9 | 11 | 12 | 14 | 600 | 2500 | 175 | 210 | Ø2.5" | Ø 3/4" |

DIMENSIONS IN MILLIMETERS 1" = 25.4 mm

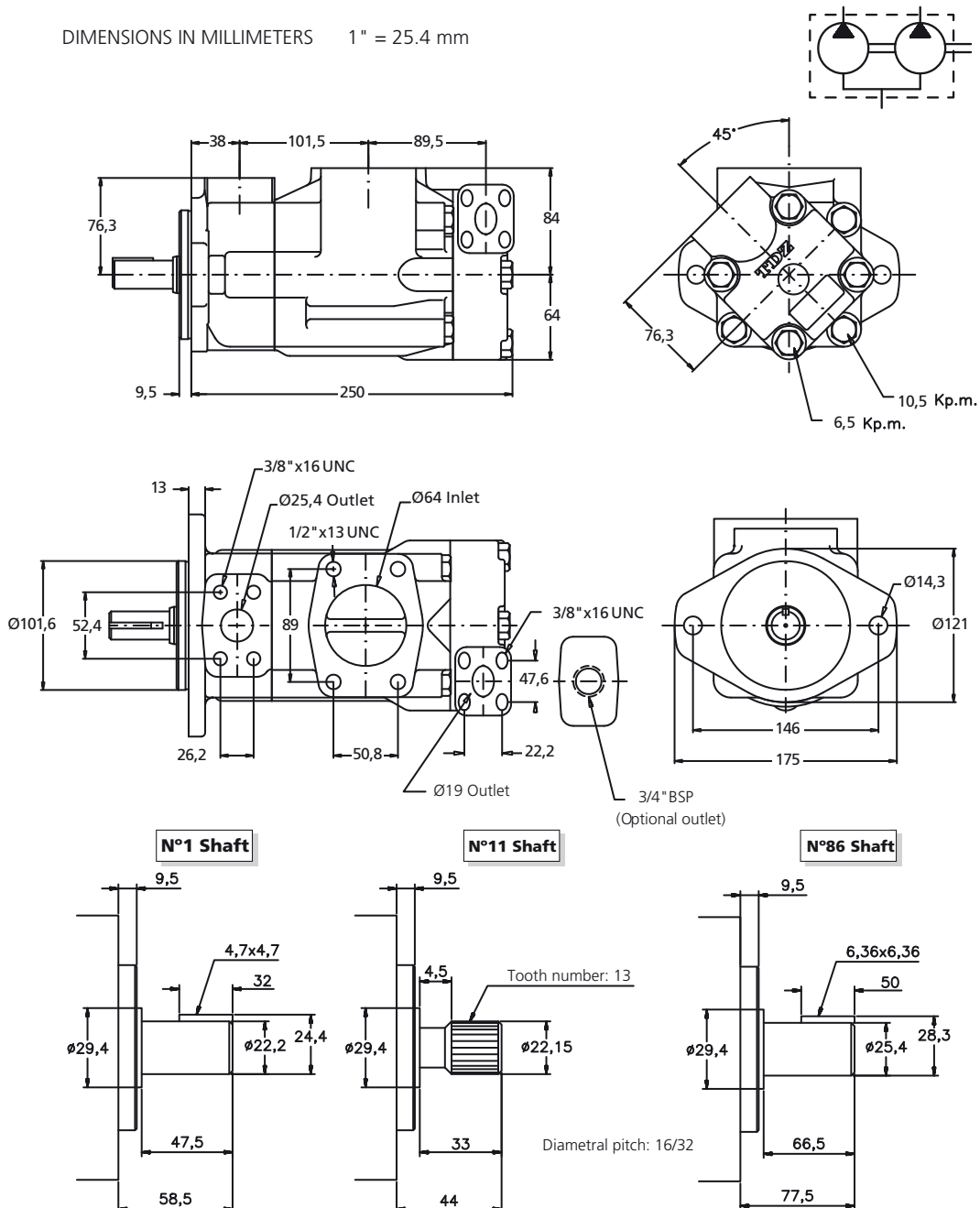

Different shafts are available





DOUBLE VANE PUMPS VS-63 Y VQ-63

| SHAFT END FLOW | | | | | | | SPEED (rpm) | | PRES (BAR) | | CONNECTION | |
|-----------------|----|----|----|-----|-----|------|-------------|-------|------------|-----------|------------|--------|
| Lts.at 1000 rpm | 66 | 81 | 97 | 112 | 121 | 142* | Min. | Max. | Contin. | Intermit. | Inlet | Outlet |
| Gal.at 1200 rpm | 21 | 25 | 30 | 35 | 38 | 45* | 600 | 2400* | 175 | 210* | Ø3" | Ø1.25" |

| COVER END FLOW | | | | | | | SPEED (rpm) | | PRES (BAR) | | CONNECTION | | |
|-----------------|---|----|----|----|----|----|-------------|------|------------|---------|------------|-------|--------|
| Lts.at 1000 rpm | 8 | 18 | 27 | 29 | 36 | 39 | 46 | Min. | Max. | Contin. | Intermit. | Inlet | Outlet |
| Gal.at 1200 rpm | 2 | 5 | 8 | 9 | 11 | 12 | 14 | 600 | 2500 | 175 | 210 | Ø3" | Ø 3/4" |

DIMENSIONS IN MILLIMETERS 1" = 25.4 mm

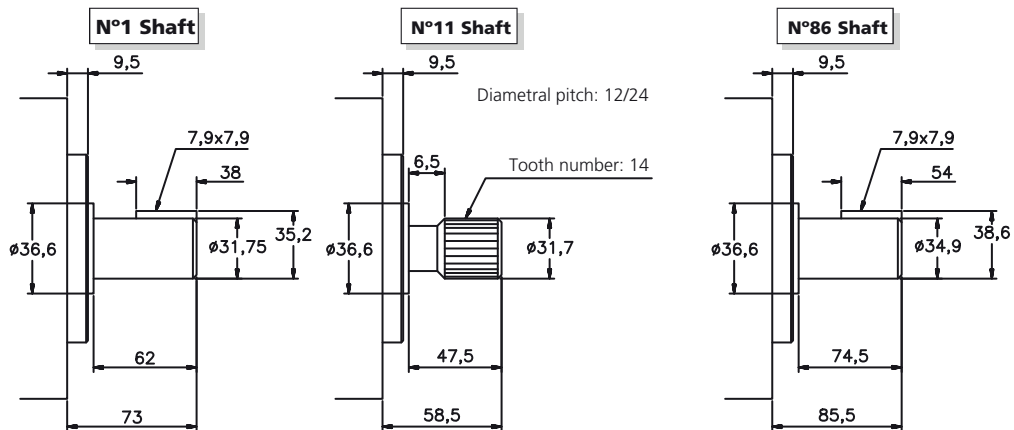
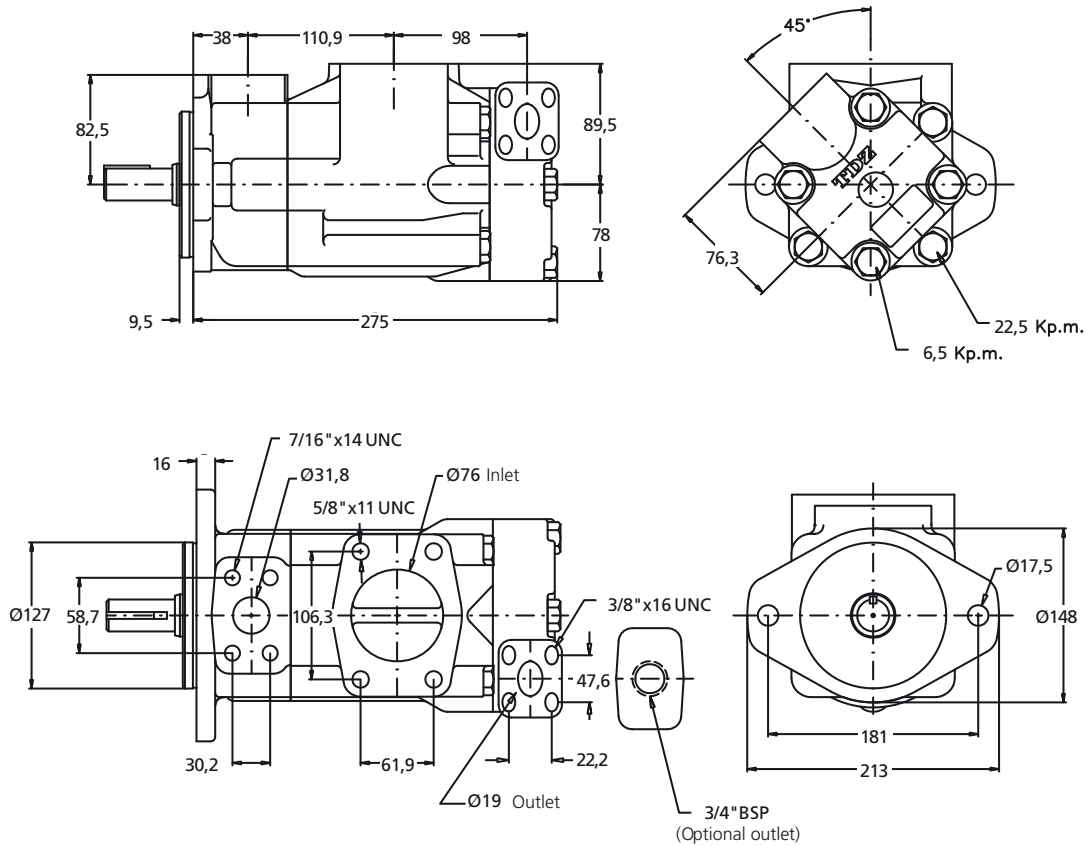

Enquire about other types of shafts



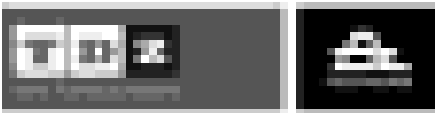

DOUBLE VANE PUMPS VS-64 Y VQ-64

| SHAFT END FLOW | | | | | | | SPEED (rpm) | | PRES (BAR) | | CONNECTION | |
|-----------------|----|----|----|-----|-----|------|-------------|-------|------------|-----------|------------|--------|
| Lts.at 1000 rpm | 66 | 81 | 97 | 112 | 121 | 142* | Min. | Max. | Contin. | Intermit. | Inlet | Outlet |
| Gal.at 1200 rpm | 21 | 25 | 30 | 35 | 38 | 45* | 600 | 2400* | 175 | 210* | Ø3" | Ø1.25" |

| COVER END FLOW | | | | | | | | SPEED(rpm) | | PRES (BAR) | | CONNECTION | | |
|-----------------|----|----|----|----|----|----|-----|------------|------|------------|---------|------------|-------|--------|
| Lts.at 1000 rpm | 26 | 40 | 45 | 55 | 60 | 67 | 80* | 88* | Min. | Max. | Contin. | Intermit. | Inlet | Outlet |
| Gal.at 1200 rpm | 8 | 12 | 14 | 17 | 19 | 21 | 24* | 27* | 600 | 2500* | 175 | 210* | Ø3" | Ø1" |

DIMENSIONS IN MILLIMETERS 1" = 25.4 mm

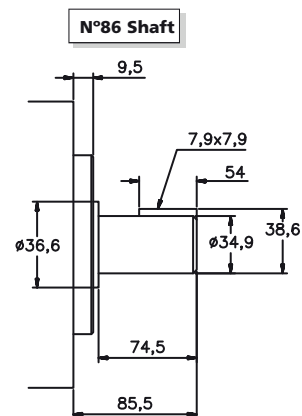
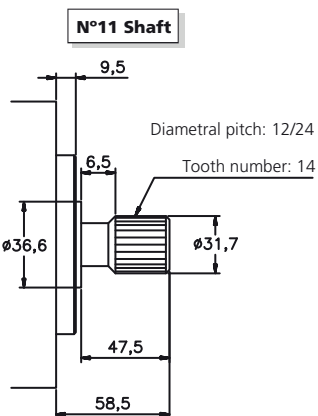
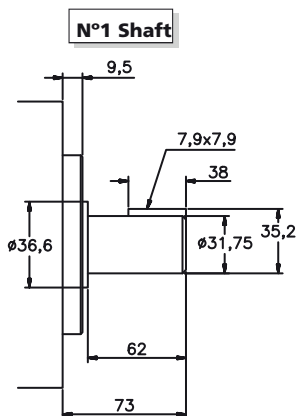
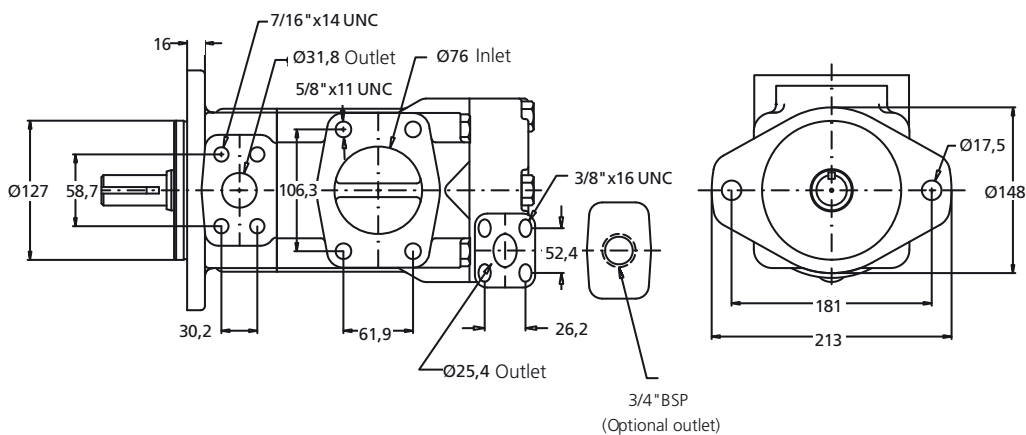
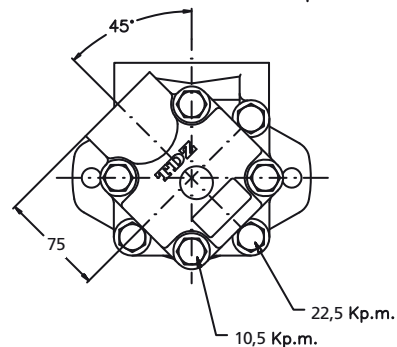
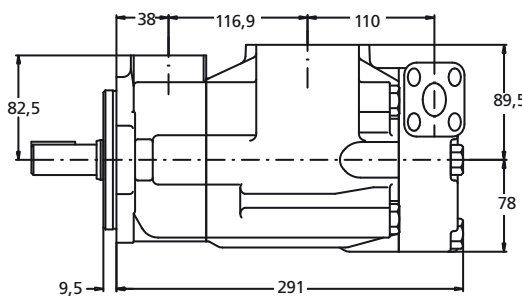
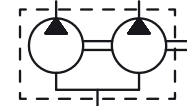

Enquire about other types of shafts





DOUBLE VANE PUMPS VS-73 Y VQ-73

| SHAFT END FLOW | | | | | | | | SPEED (rpm) | | PRES (BAR) | | CONNECTION | |
|-----------------|-----|-----|-----|-----|-----|-----|-----|-------------|-------|------------|-----------|------------|--------|
| Lts.a 1000 rpm | 138 | 148 | 162 | 180 | 193 | 214 | 240 | Min. | Máx. | Contin. | Intermit. | Inlet | Outlet |
| Gal. a 1200 rpm | 42 | 47 | 50 | 57 | 60 | 67 | 75 | 600 | 2200* | 155 | 175 | Ø3.5" | Ø1.5" |

| COVER END FLOW | | | | | | | | SPEED (rpm) | | PRES (BAR) | | CONNECTION | |
|-----------------|---|----|----|----|----|----|----|-------------|------|------------|-----------|------------|--------|
| Lts.at 1000 rpm | 8 | 18 | 27 | 29 | 36 | 39 | 46 | Min. | Max. | Contin. | Intermit. | Inlet | Outlet |
| Gal.at 1200 rpm | 2 | 5 | 8 | 9 | 11 | 12 | 14 | 600 | 2500 | 175 | 210 | Ø3.5" | Ø 3/4" |

DIMENSIONS IN MILLIMETERS 1" = 25.4 mm

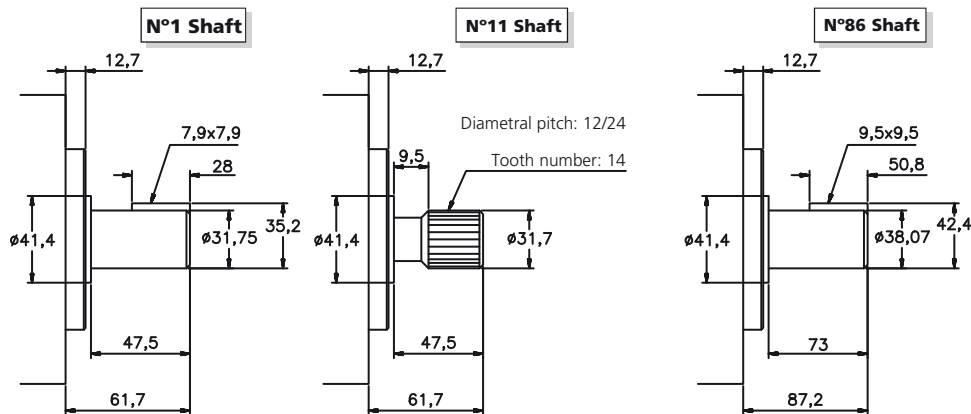
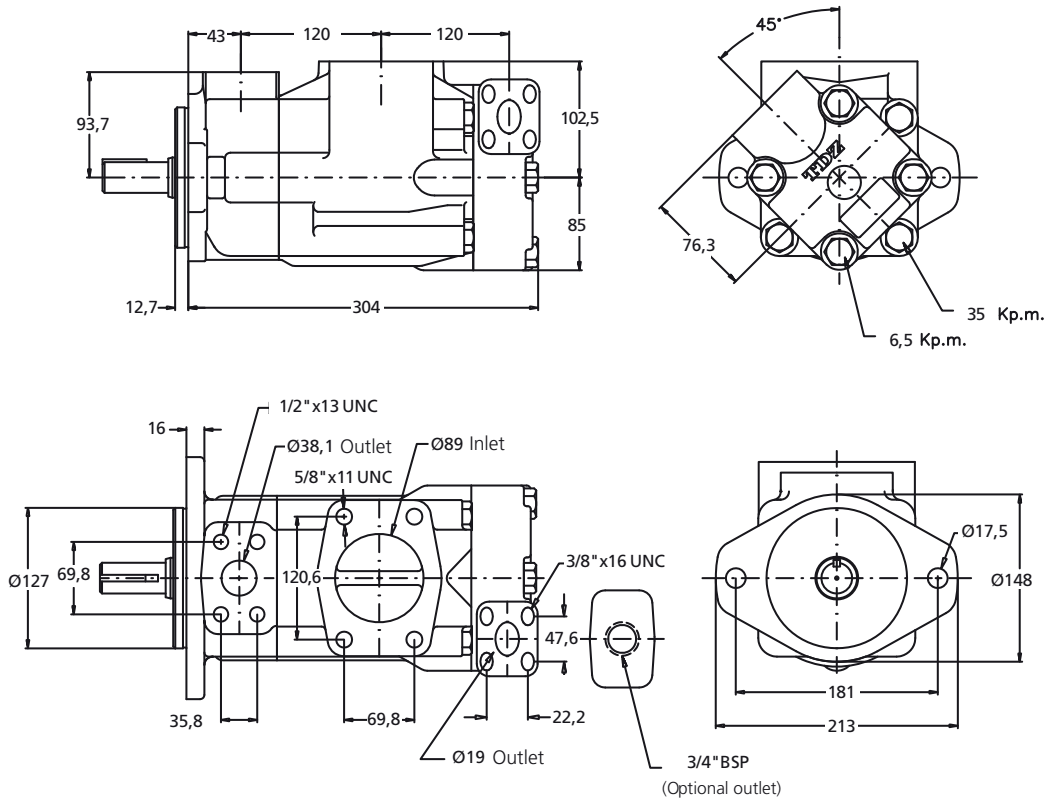

Enquire about other types of shafts



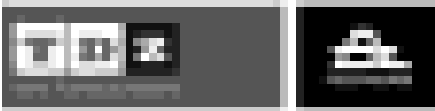

V* DOUBLE VANE PUMPS

DOUBLE VANE PUMPS VS-74 Y VQ-74

| SHAFT END FLOW | | | | | | | | SPEED (rpm) | | PRES (BAR) | | CONNECTION | |
|-----------------|-----|-----|-----|-----|-----|-----|-----|-------------|-------|------------|-----------|------------|--------|
| | | | | | | | | Min. | Max. | Contin. | Intermit. | Inlet | Outlet |
| Lts.a 1000 rpm | 138 | 148 | 162 | 180 | 193 | 214 | 240 | 600 | 2200* | 155 | 175 | Ø3.5" | Ø1.5" |
| Gal. a 1200 rpm | 42 | 47 | 50 | 57 | 60 | 67 | 75 | | | | | | |

| COVER END FLOW | | | | | | | | SPEED (rpm) | | PRES (BAR) | | CONNECTION | | |
|-----------------|----|----|----|----|----|----|-----|-------------|------|------------|-----------|------------|--------|-----|
| | | | | | | | | Min. | Max. | Contin. | Intermit. | Inlet | Outlet | |
| Lts.at 1000 rpm | 26 | 40 | 45 | 55 | 60 | 67 | 80* | 88* | 600 | 2500* | 175 | 210* | Ø3.5" | Ø1" |
| Gal.at 1200 rpm | 8 | 12 | 14 | 17 | 19 | 21 | 24* | 27* | | | | | | |

DIMENSIONS IN MILLIMETERS 1" = 25.4 mm

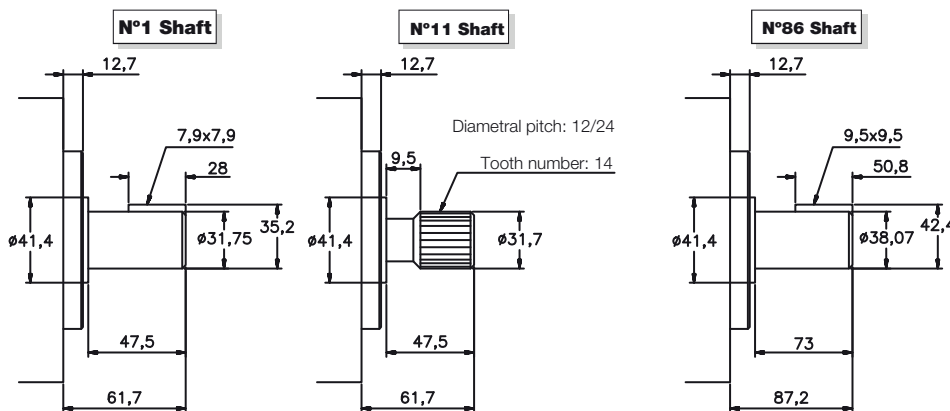
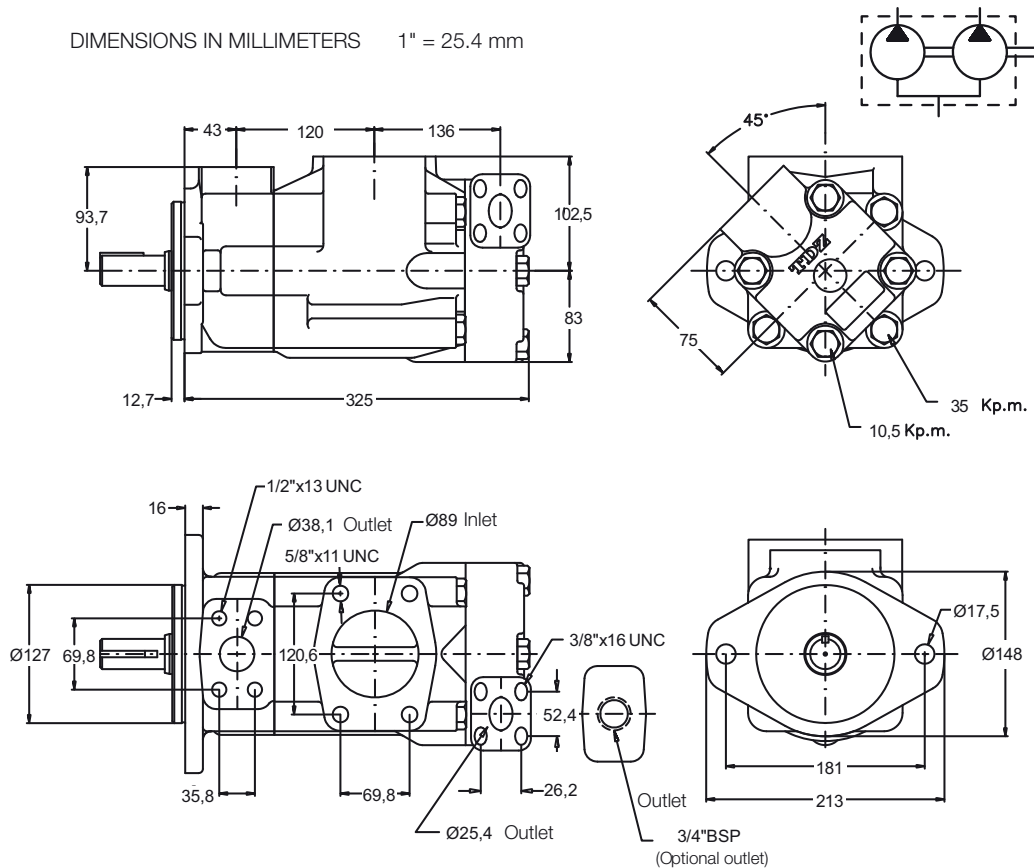

Enquire about other types of shafts





DOUBLE VANE PUMPS VS-76 Y VQ-76

| SHAFT END FLOW | | | | | | SPEED (rpm) | | PRES (BAR) | | CONNECTION | | | |
|-----------------|-----|-----|-----|-----|-----|-------------|-----|------------|-------|------------|-----------|-------|--------|
| Lts. a 1000 rpm | 138 | 148 | 162 | 180 | 193 | 214 | 240 | Min. | Max. | Contin. | Intermit. | Inlet | Outlet |
| Gal. a 1200 rpm | 42 | 47 | 50 | 57 | 60 | 67 | 75 | 600 | 2200* | 155 | 175 | Ø4" | Ø1.5" |

| COVER END FLOW | | | | | | SPEED (rpm) | | PRES (BAR) | | CONNECTION | | | |
|------------------|----|----|----|-----|-----|-------------|--|------------|-------|------------|-----------|-------|--------|
| Lts. at 1000 rpm | 66 | 81 | 97 | 112 | 121 | 142* | | Min. | Max. | Contin. | Intermit. | Inlet | Outlet |
| Gal. at 1200 rpm | 21 | 25 | 30 | 35 | 38 | 45* | | 600 | 2400* | 175 | 210* | Ø4" | Ø1.25" |

DIMENSIONS IN MILLIMETERS 1" = 25.4 mm

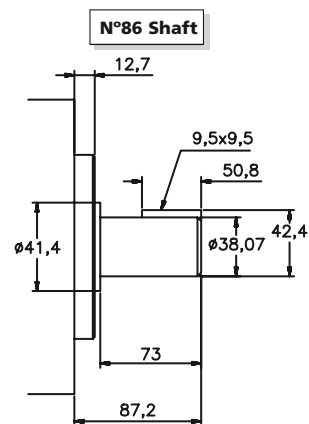
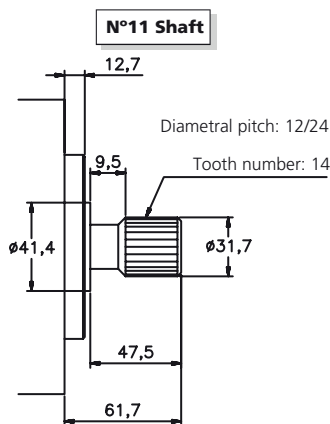
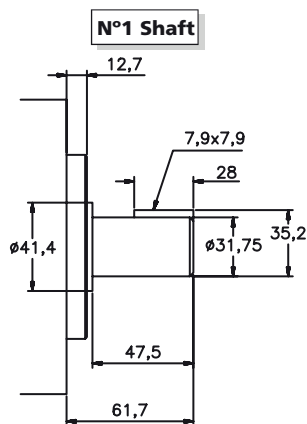
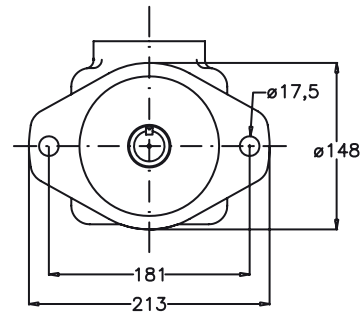
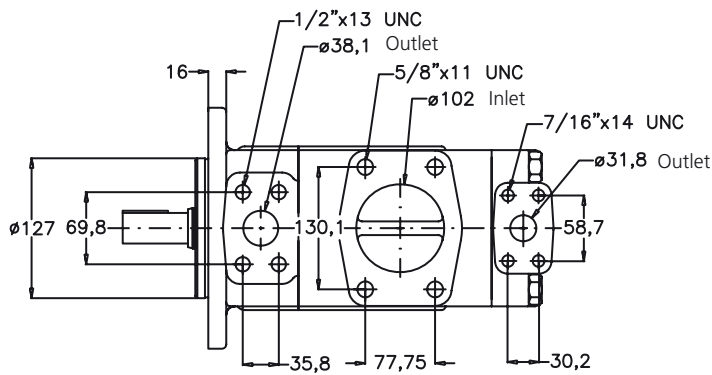
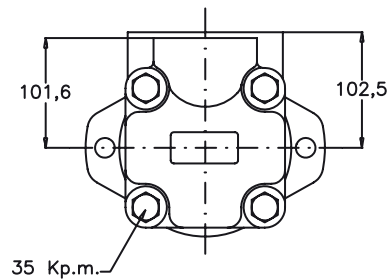
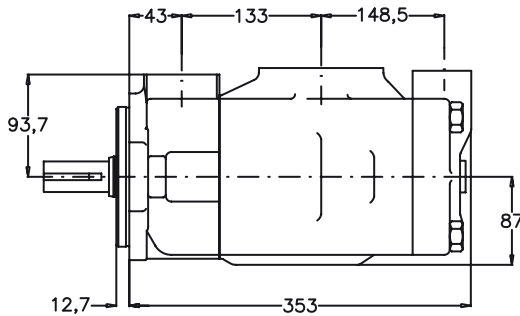

Enquire about other types of shafts

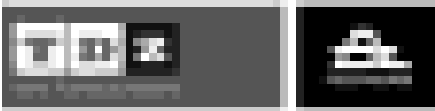

DT6 DOUBLE VANE PUMPS ORDERING CODE

DATA SHEET

DT6* - CC - * - B - 17/14 - 1 - R - 00 - B - 1 - 00

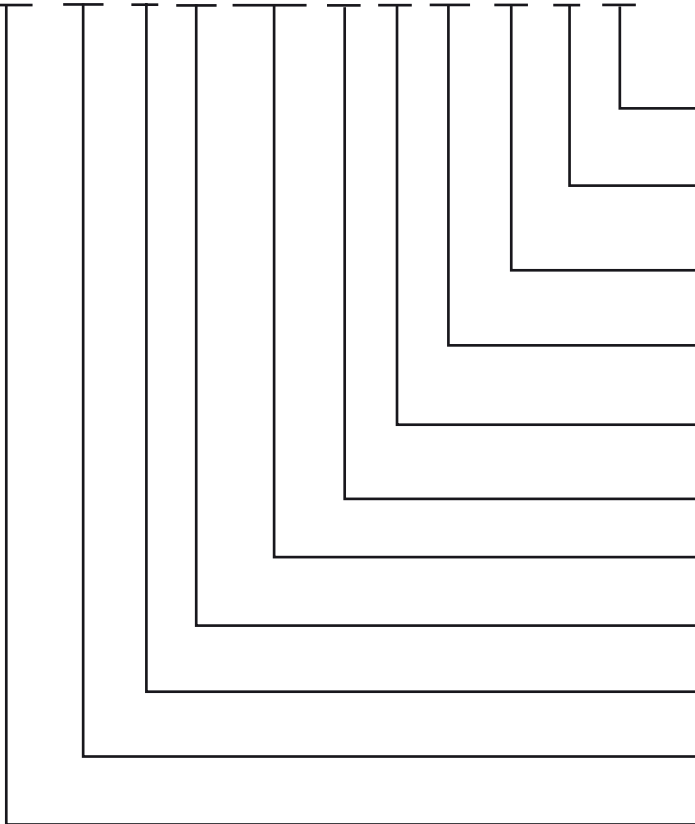

- Special threads (ask for available threads)
UNC: 00, 01, 10, 11
Metric: 0M, W0, 1M, W1
- Seal Class 1: NBR
2: VITON
- Design letter
- Porting combination (see diagrams)
(Viewed from shaft)
- Direction of rotation R: clockwise
L: counterclockwise
- Type of Shaft (see particular pump model)
- Flow (see particular pump model)
- Bidirectional
M: 1 shaft seal
P: 2 shaft seals
*: special shafts only
- Size (CC, DC, EC, ED)
- Vane pumps "DT6" series



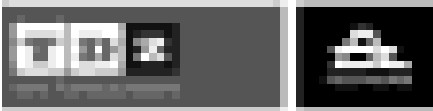

GENERAL CHARACTERISTICS

GENERAL CHARACTERISTICS

DOUBLE VANE PUMPS

| Pump Model | P1 | | | P2 | | | Maxim. speed | Minim. speed | Front flange standard SAE j744c ISO 3019-1 | Weight Kgs | SAE 4 Holes flange | | |
|----------------|-----------------|---|---------------------|-----------------|---|---------------------|--------------|--------------|--|------------|--------------------|----------------|--|
| | Cartridge Model | Theoretical displacement Cm ³ /rev | Maxim. Pressure Bar | Cartridge Model | Theoretical displacement Cm ³ /rev | Maxim. Pressure Bar | | | | | Suction S | Pressure P1 P2 | |
| DT6CC/M | 003 a 031 | 10.8 a 100 | 275 | 003 a 031 | 10.8 a 100 | 275 | 2800 | 400 | SAE B | 26 | 2 1/2" x 6 3/4" | 1" x 1 6 3/4" | |
| DT6DC/M | 014 a 061 | 47.6 a 190.5 | 240 | 003 a 031 | 10.8 a 100 | 275 | 2800 | 400 | SAE C | 37 | 3" | 1 1/4" x 1" | |
| DT6EC/M | 042 a 085 | 132.3 a 269.8 | 240 | 003 a 031 | 10.8 a 100 | 275 | 2200 | 400 | SAE C | 55 | 3 1/2" | 1 1/2" x 1" | |
| DT6ED/M | 042 a 085 | 132.3 a 268.8 | 240 | 014 a 061 | 47.6 a 190.5 | 240 | 2200 | 400 | SAE C | 66 | 4" | 1 1/2" x 1" | |

C - 025,028,031 - 2500 rpm maximum 028,031 - 210 bar max intermitent
 D - 042,045,050 - 2200 rpm maximum 050 - 210 bar maximum intermitent - 061 - 120 bar maximum intermitent
 E - 085 - 2000 rpm maximum - 90 bar maximum intermitent

Above mentioned values of maximum speed and maximum pressure are based on use of antiwear oil only. Please contact **TDZ** for particular values when different fluids are used, (synthetic fluids, water in oil emulsions, water glycol, etcetera)

DOUBLE VANE PUMPS - PORTING COMBINATION DT6CC-DT6DC-DT6EC

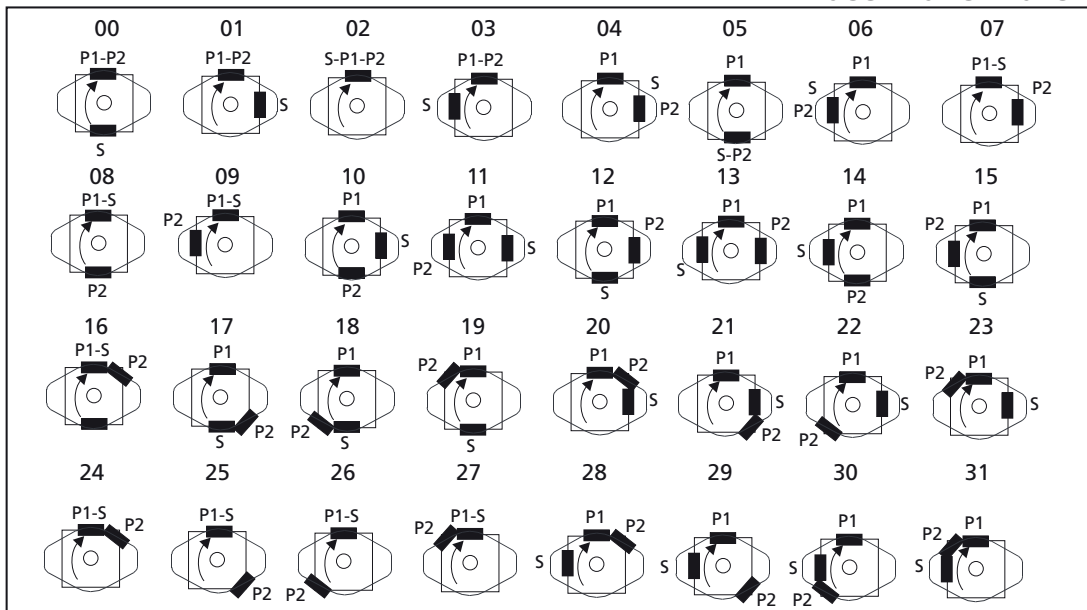

DOUBLE VANE PUMPS - PORTING COMBINATION DT6ED

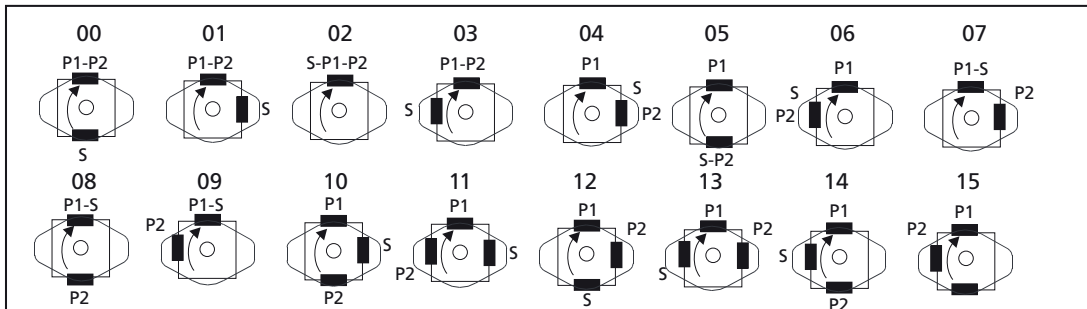

S= Suction port | P1= Shaft end pressure port | P2= Cover end pressure port



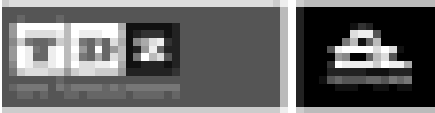

DOUBLE PUMPS DT6CC - OPERATING CHARACTERISTICS

SHAFT END SECTION

| | FLOW | | | | | | | | | | | | | SPEED (rpm) | | PRESSURE (bar) | |
|---------------------|---------------------|----|----|----|----|----|----|----|----|----|----|----|----|-------------|-------|----------------|-----------|
| | Lts/min.at 1000 rpm | 11 | 17 | 21 | 26 | 34 | 37 | 46 | 58 | 64 | 70 | 79 | 89 | 100 | Min. | Máx. | Intermit. |
| Gal/min.at 1200 rpm | 3 | 5 | 6 | 8 | 10 | 12 | 14 | 17 | 20 | 22 | 25 | 28 | 31 | 500 | 2800* | 275 | 240* |

* See page 41 for further information about speed & pressure.

COVER END SECTION

| | FLOW | | | | | | | | | | | | | SPEED (rpm) | | PRESSURE (bar) | |
|---------------------|---------------------|----|----|----|----|----|----|----|----|----|----|----|----|-------------|-------|----------------|-----------|
| | Lts/min.at 1000 rpm | 11 | 17 | 21 | 26 | 34 | 37 | 46 | 58 | 64 | 70 | 79 | 89 | 100 | Min. | Máx. | Intermit. |
| Gal/min.at 1200 rpm | 3 | 5 | 6 | 8 | 10 | 12 | 14 | 17 | 20 | 22 | 25 | 28 | 31 | 500 | 2800* | 275 | 240* |

* See page 41 for further information about speed & pressure.

DT6CC - FLOW & INPUT POWER DIAGRAMS

SHAFT END

See **DT6C** Single Pumps for flow and input power diagrams (page 42)

COVER END

See **DT6C** Single Pumps for flow and input power diagrams (page 42)





DOUBLE PUMPS DT6CC - DIMENSIONS

DIMENSIONS IN MILLIMETERS. 1" = 25,4 mm

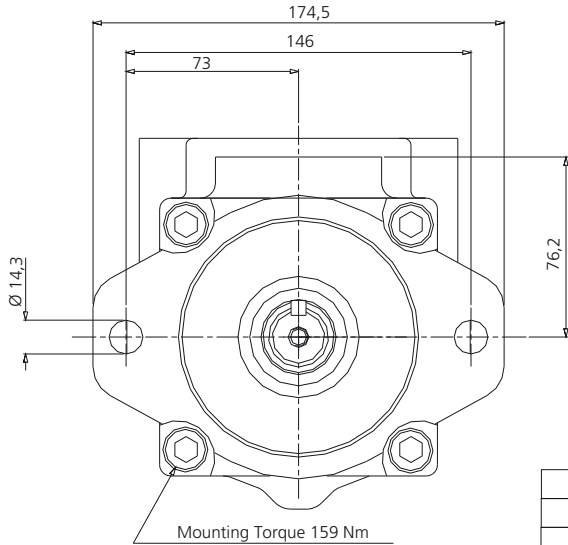

Suction and pressure Port dimension variables.

| Thread | Port | A | B | C | D | E |
|--------|--------|-------|------|------|------|-------------------|
| S | 3" | 106,4 | 61,9 | 76,2 | | 5/8"-11UNC x 28,4 |
| S | 2 1/2" | 88,9 | 50,8 | 63,5 | | 1/2"-13UNC x 23,9 |
| P1 | 1" | 52,4 | 26,2 | 25,4 | 76,2 | |
| P2 | 3/4" | 47,7 | 22,4 | 19,0 | 76,2 | |
| P2 | 1" | 52,4 | 26,2 | 25,4 | 74,7 | |

*Add the following numbers at the end of the DT6CC reference depending your option.

| | Code 00* | Code 01* | Code 10* | Code 11* |
|----|----------|----------|----------|----------|
| S | 3" | 3" | 2 1/2" | 2 1/2" |
| P1 | 1" | 1" | 1" | 1" |
| P2 | 1" | 3/4" | 1" | 3/4" |

You may use suction "S" of 2 1/2" for 126 cc/rev. maximum
 You may use pressure port "P2" of 3/4" for 46 cc/rev. maximum

| Pump | Shaft code | V x P max (P1+P2) |
|--------------|------------|-------------------|
| DT6CC | 1 | 14300 |
| | 2 | 21470 |
| | 3 | 32670 |
| | 5 | 20600 |

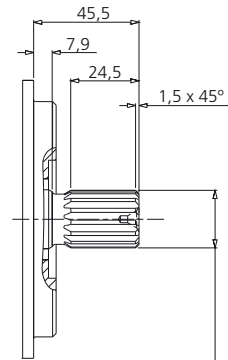
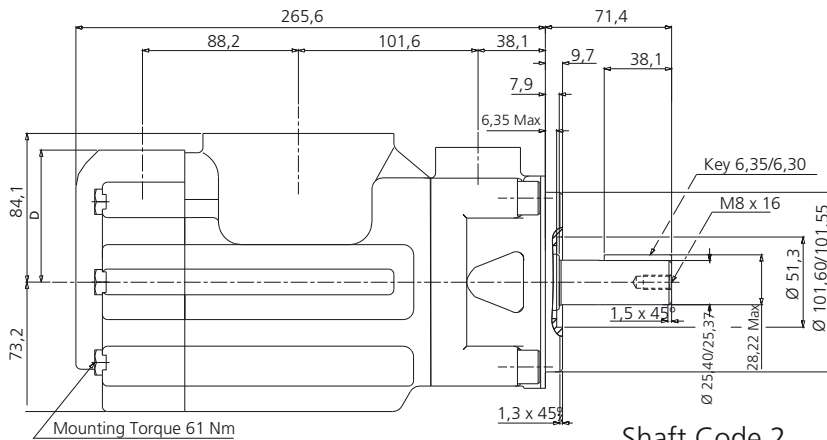

Shaft Code 3

SAE BB Splined shaft
 1-J498b 16/32 d.p. -
 15 Teeth
 30° Pressure angle

Shaft Code 2

SAE BB

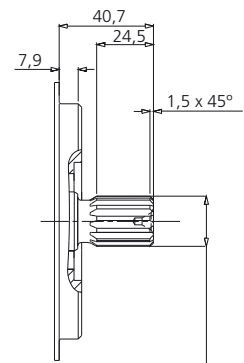
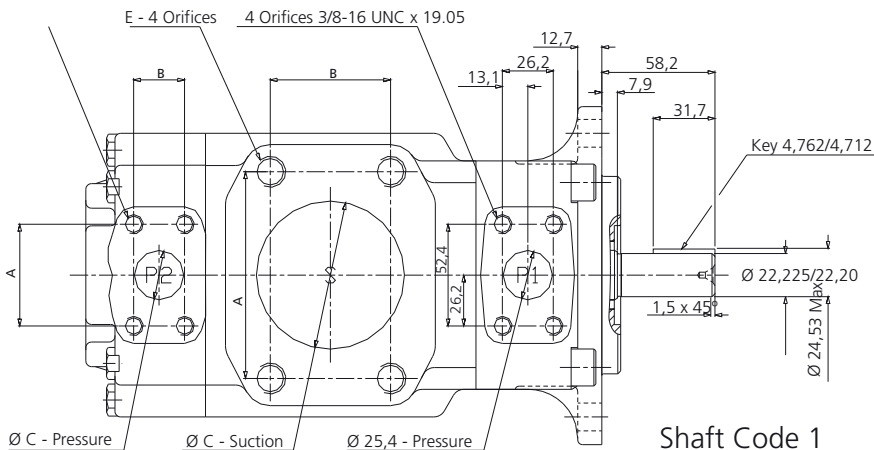

Shaft Code 5

SAE B Splined shaft
 1-J498b 16/32 d.p. -
 13 Teeth
 30° Pressure angle

Shaft Code 1

Keyed no SAE



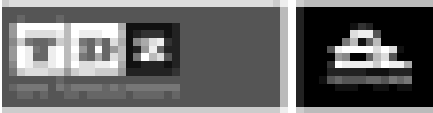

DT6DC - OPERATING CHARACTERISTICS

SHAFT END SECTION

| FLOW | | | | | | | | | | | SPEED (rpm) | | PRESSURE (bar) | | |
|---------------------|----|----|----|----|----|-----|-----|-----|-----|-----|-------------|---------------------|----------------|-----------|---------|
| Lts/min.at 1000 rpm | 48 | 66 | 80 | 90 | 98 | 111 | 120 | 136 | 146 | 158 | 191 | Min. | Máx. | Intermit. | Contin. |
| | | | | | | | | | | | | Gal/min.at 1200 rpm | 14 | 20 | 24 |

* See page 41 for further information about speed & pressure.

COVER END SECTION

| FLOW | | | | | | | | | | | SPEED (rpm) | | PRESSURE (bar) | | | | |
|---------------------|----|----|----|----|----|----|----|----|----|----|-------------|----|----------------|---------------------|------|-----------|---------|
| Lts/min.at 1000 rpm | 11 | 17 | 21 | 26 | 34 | 37 | 46 | 58 | 64 | 70 | 79 | 89 | 100 | Min. | Máx. | Intermit. | Contin. |
| | | | | | | | | | | | | | | Gal/min.at 1200 rpm | 3 | 5 | 6 |

* See page 41 for further information about speed & pressure.

DT6DC - FLOW & INPUT POWER DIAGRAMS

SHAFT END

See **DT6D** Single Pumps for flow and input power diagrams (page 44)

COVER END

See **DT6D** Single Pumps for flow and input power diagrams (page 42)





DOUBLE PUMPS DT6DC - DIMENSIONS

DIMENSIONS IN MILLIMETERS. 1" = 25,4 mm

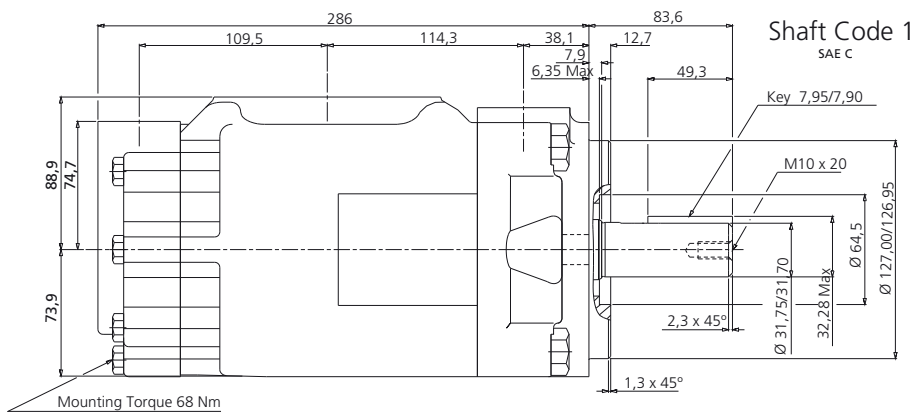
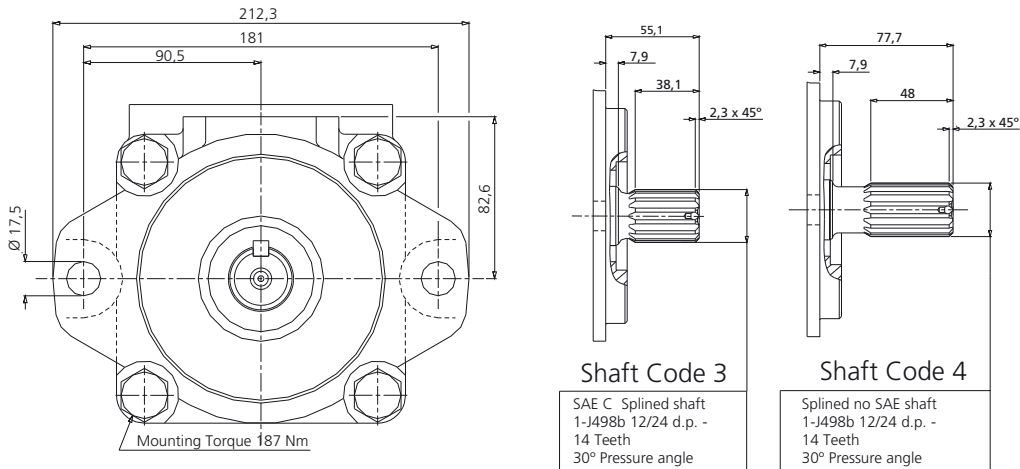

| Shaft Torque Limits (cc/rev x bar) | | |
|------------------------------------|------------|-------------------|
| Pumps | Shaft code | V x P max (P1+P2) |
| DT6DC | 1 | 43240 |
| | 2 | 38996 |

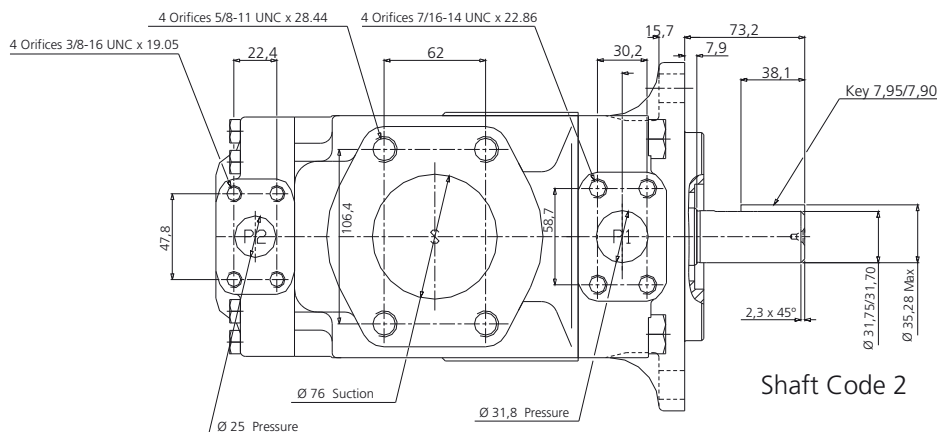

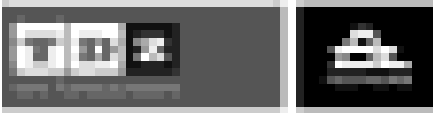

DT6EC - OPERATING CHARACTERISTICS

SHAFT END SECTION

| FLOW | | | | | | | | | SPEED (rpm) | | PRESSURE (bar) | |
|---------------------|-----|-----|-----|-----|-----|-----|-----|-----|-------------|-------|----------------|---------|
| Lts/min.at 1000 rpm | 132 | 142 | 156 | 165 | 197 | 213 | 227 | 270 | Min. | Máx. | Intermit. | Contin. |
| Gal/min.at 1200 rpm | 42 | 45 | 50 | 52 | 62 | 66 | 72 | 85 | 500 | 2200* | 240 | 210 |

* See page 41 for further information about speed & pressure.

COVER END SECTION

| FLOW | | | | | | | | | | | | | SPEED (rpm) | | PRESSURE (bar) | | |
|---------------------|----|----|----|----|----|----|----|----|----|----|----|----|-------------|------|----------------|-----------|---------|
| Lts/min.at 1000 rpm | 11 | 17 | 21 | 26 | 34 | 37 | 46 | 58 | 64 | 70 | 79 | 89 | 100 | Min. | Máx. | Intermit. | Contin. |
| Gal/min.at 1200 rpm | 3 | 5 | 6 | 8 | 10 | 12 | 14 | 17 | 20 | 22 | 25 | 28 | 31 | 500 | 2800* | 275 | 240* |

* See page 41 for further information about speed & pressure.

DT6EC - FLOW & INPUT POWER DIAGRAMS

SHAFT END

See **DT6E** Single Pumps for flow and input power diagrams (page 46)

COVER END

See **DT6C** Single Pumps for flow and input power diagrams (page 42)





DOUBLE PUMPS DT6EC - DIMENSIONS

DIMENSIONS IN MILLIMETERS. 1" = 25,4 mm

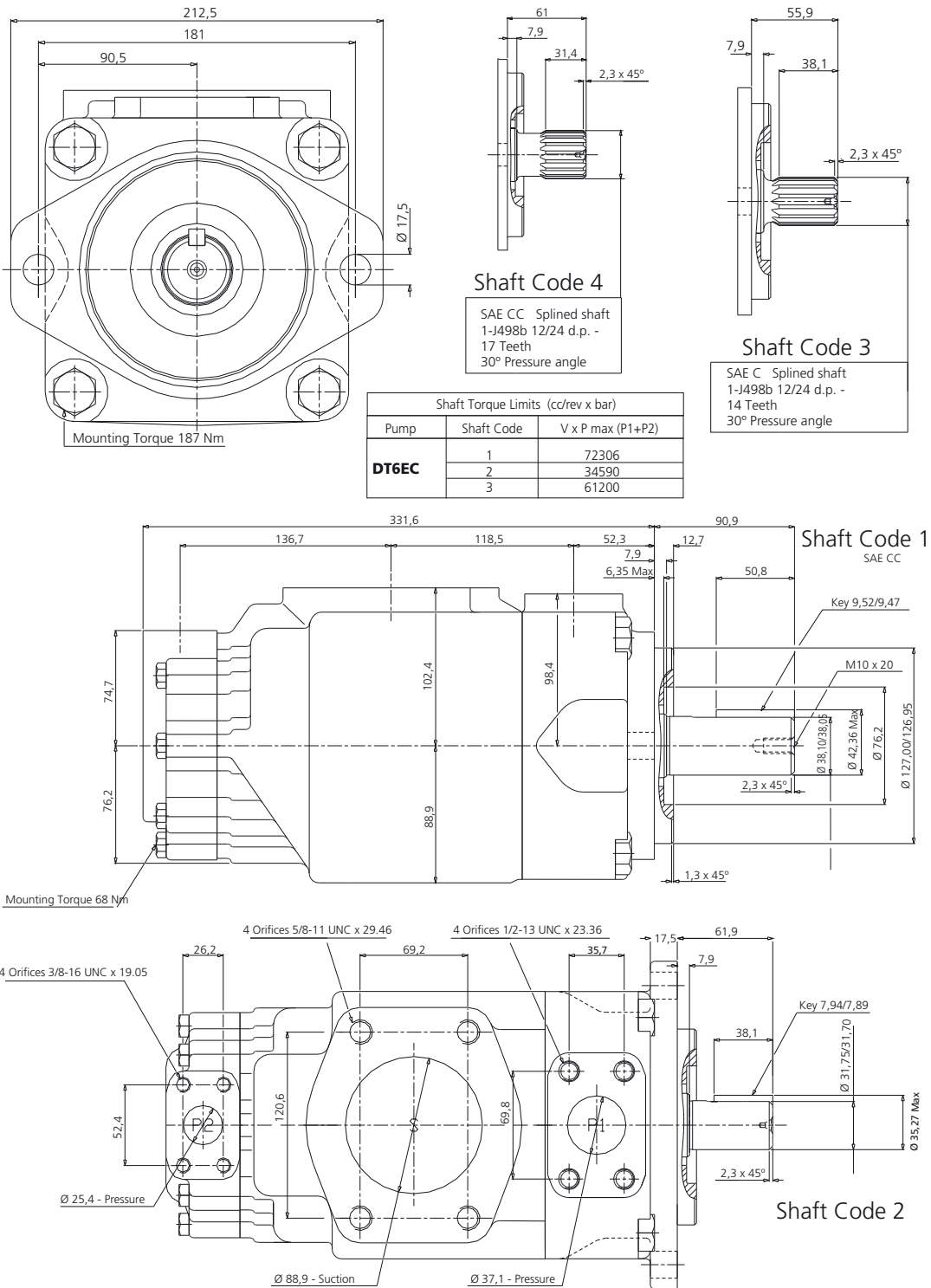



DT6ED - OPERATING CHARACTERISTICS

SHAFT END SECTION

| FLOW | | | | | | | | | SPEED (rpm) | | PRESSURE (bar) | |
|---------------------|-----|-----|-----|-----|-----|-----|-----|-----|-------------|-------|----------------|---------|
| Lts/min.at 1000 rpm | 132 | 142 | 156 | 165 | 197 | 213 | 227 | 270 | Min. | Máx. | Intermit. | Contin. |
| Gal/min.at 1200 rpm | 42 | 45 | 50 | 52 | 62 | 66 | 72 | 85 | 500 | 2200* | 240 | 210 |

* See page 41 for further information about speed & pressure.

COVER END SECTION

| FLOW | | | | | | | | | | | SPEED (rpm) | | PRESSURE (bar) | | |
|---------------------|----|----|----|----|----|-----|-----|-----|-----|-----|-------------|------|----------------|-----------|---------|
| Lts/min.at 1000 rpm | 48 | 66 | 80 | 90 | 98 | 111 | 120 | 136 | 146 | 158 | 191 | Min. | Máx. | Intermit. | Contin. |
| Gal/min.at 1200 rpm | 14 | 20 | 24 | 28 | 31 | 35 | 38 | 42 | 45 | 50 | 61 | 500 | 2500* | 240 | 210 |

* See page 41 for further information about speed & pressure.

DT6ED - FLOW & INPUT POWER DIAGRAMS

SHAFT END

See **DT6E** Single Pumps for flow and input power diagrams (page 46)

COVER END

See **DT6D** Single Pumps for flow and input power diagrams (page 44)





DOUBLE PUMPS DT6ED - DIMENSIONS

DIMENSIONS IN MILLIMETERS. 1" = 25,4 mm

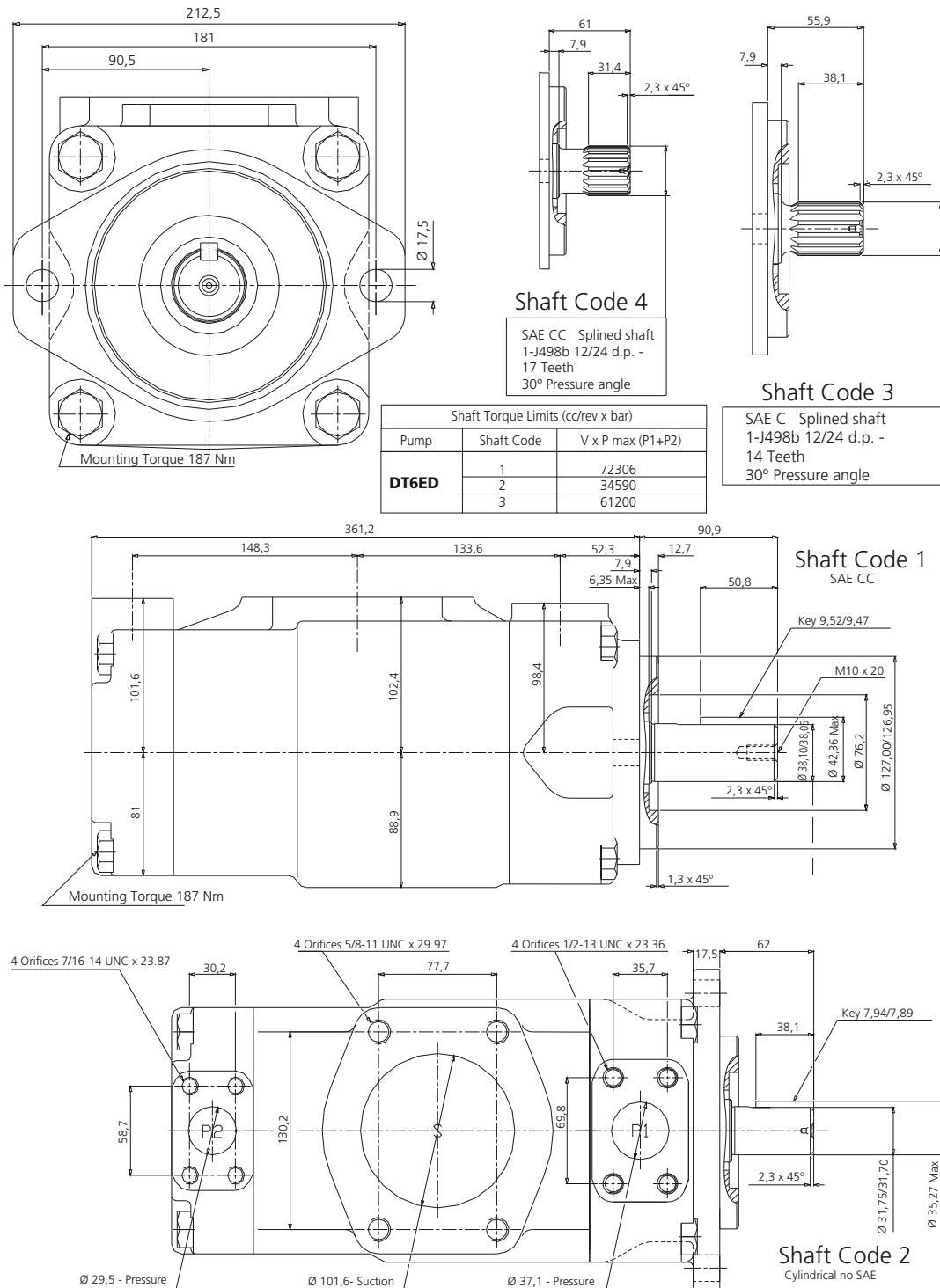



TRIPLE VANE PUMPS

DT6 Triple vane pumps

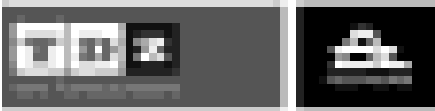

DT6 TRIPLE VANE PUMPS ORDERING CODE

DATA SHEET

DT6 - DCC - B - 62/38/70 - 1 - R - 00 - B - 1 - 00

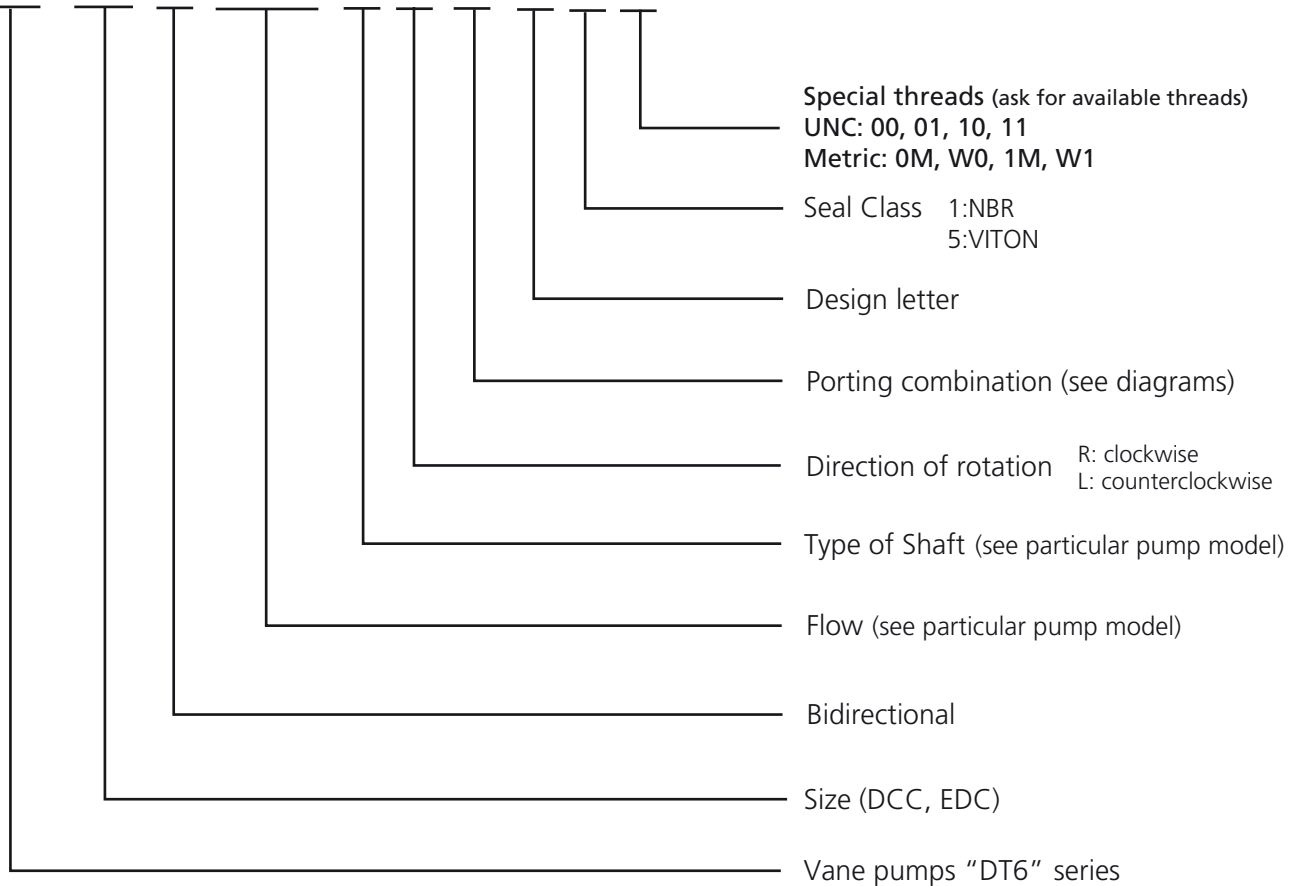



DT6 TRIPLE VANE PUMPS - GENERAL CHARACTERISTICS

TRIPLE VANE PUMPS

| Series | P1 | | | P2 | | | P3 | | | Maximum speed | Front Flange Standard SAE j744c ISO 3019-1 | Weight Kgs | SAE 4 holes flange | | | |
|---------------|-----------------|---|------------------|-----------------|---|------------------|-----------------|---|------------------|---------------|--|------------|--------------------|----------|-------|------------|
| | Cartridge model | Theoretical displacem. Cm ³ /rev | Maximum Pressure | Cartridge model | Theoretical displacem. Cm ³ /rev | Maximum Pressure | Cartridge model | Theoretical displacem. Cm ³ /rev | Maximum Pressure | | | | Suction S | Pressure | | |
| | | | | | | | | | | | | | | P1 | P2 | P3 |
| DT6DCC | 014 - 061 | 47.6 - 190.5 | 240 | 003 - 031 | 10.8 - 100 | 275 | 003 - 031 | 10.8 - 100 | 275 | 2500 | SAE C | 61 | 4" | 1.25" | 1" | 1" or 3/4" |
| DT6EDC | 042 - 085 | 132.3 - 269.8 | 240 | 014 - 061 | 47.6 - 190.5 | 240 | 003 - 031 | 10.8 - 100 | 275 | 2200 | ISO 3019-2 | 100 | 4" | 1.5" | 1.25" | 1" or 3/4" |

C - 025,028,031 - 2500 rpm maximum, 028,031 - 210 bar maximum intermittent
D - 042,045,050 - 2200 rpm maximum, 050 - 210 bar maximum intermittent - 061 - 120 bar max intermittent
E - 085 - 2000 rpm max - 90 bar maximum intermittent

TRIPLE VANE PUMPS - PORTING COMBINATION

DT6DCC-DT6EDC

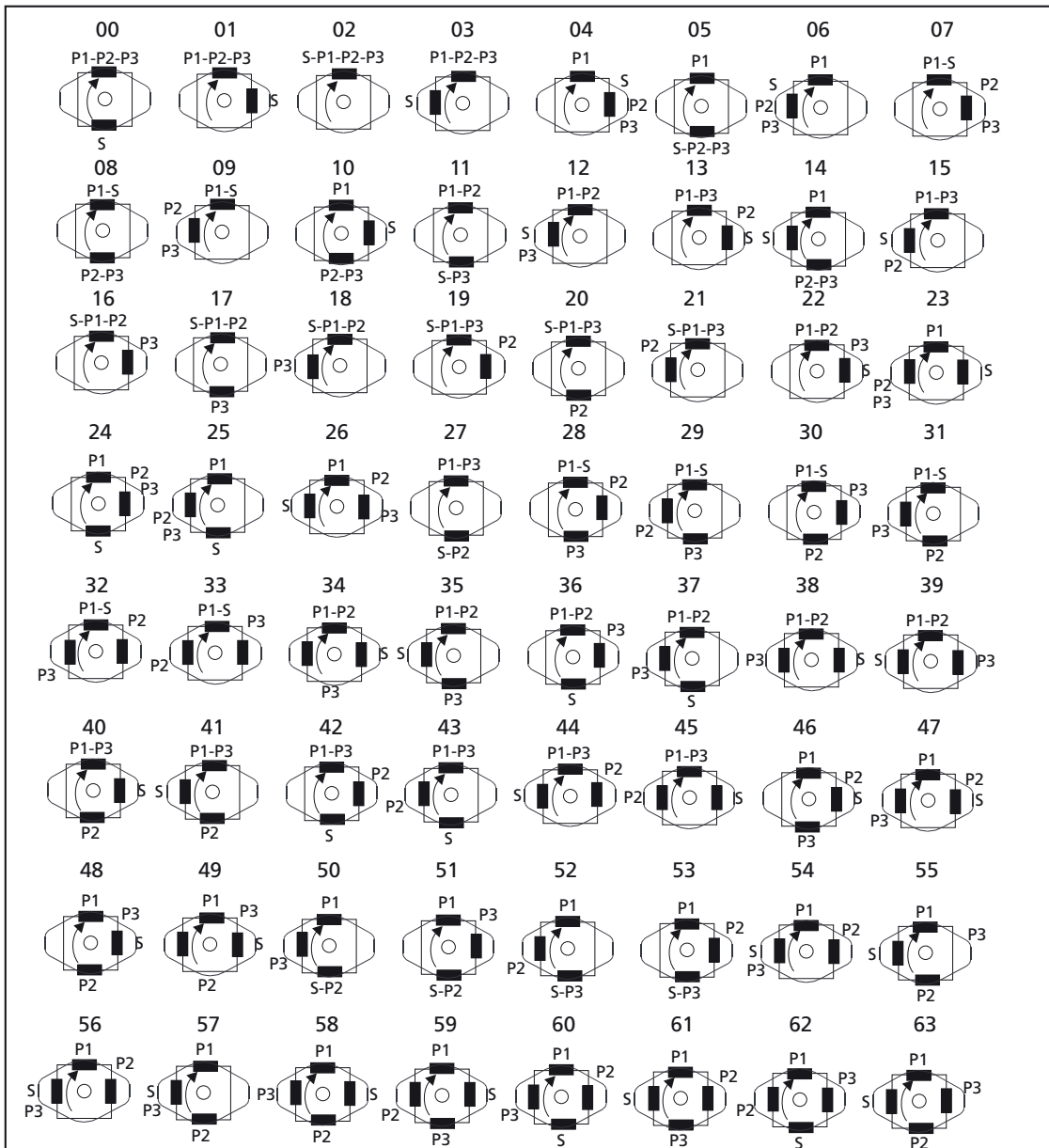

S= Suction port | P1= Shaft end pressure port | P2= Middle pressure port | P3= Cover end pressure port



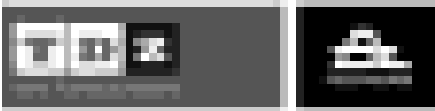

DT6DCC - OPERATING CHARACTERISTICS

SHAFT END SECTION

| FLOW | | | | | | | | | | | SPEED (rpm) | | PRESSURE (bar) | | |
|---------------------|----|----|----|----|----|-----|-----|-----|-----|-----|-------------|------|----------------|-----------|---------|
| Lts/min.at 1000 rpm | 48 | 66 | 80 | 90 | 98 | 111 | 120 | 136 | 146 | 158 | 191 | Mín. | Máx. | Intermit. | Contin. |
| Gal/min.at 1200 rpm | 14 | 20 | 24 | 28 | 31 | 35 | 38 | 42 | 45 | 50 | 61 | 500 | 2500* | 240 | 210 |

* See page 41 for further information about speed & pressure.

MIDDLE SECTION

| FLOW | | | | | | | | | | | SPEED (rpm) | | PRESSURE (bar) | | | | |
|---------------------|----|----|----|----|----|----|----|----|----|----|-------------|----|----------------|------|-------|-----------|---------|
| Lts/min.at 1000 rpm | 11 | 17 | 21 | 26 | 34 | 37 | 46 | 58 | 64 | 70 | 79 | 89 | 100 | Mín. | Máx. | Intermit. | Contin. |
| Gal/min.at 1200 rpm | 3 | 5 | 6 | 8 | 10 | 12 | 14 | 17 | 20 | 22 | 25 | 28 | 31 | 500 | 2800* | 275 | 240* |

* See page 41 for further information about speed & pressure.

COVER END SECTION

| FLOW | | | | | | | | | | | SPEED (rpm) | | PRESSURE (bar) | | | | |
|---------------------|----|----|----|----|----|----|----|----|----|----|-------------|----|----------------|------|-------|-----------|---------|
| Lts/min.at 1000 rpm | 11 | 17 | 21 | 26 | 34 | 37 | 46 | 58 | 64 | 70 | 79 | 89 | 100 | Mín. | Máx. | Intermit. | Contin. |
| Gal/min.at 1200 rpm | 3 | 5 | 6 | 8 | 10 | 12 | 14 | 17 | 20 | 22 | 25 | 28 | 31 | 500 | 2800* | 275 | 240* |

* See page 41 for further information about speed & pressure.

DT6DCC - FLOW & INPUT POWER DIAGRAMS

SHAFT END

See **DT6D** Single Pumps for flow and input power diagrams (page 44)

MIDDLE BODY

See **DT6C** Single Pumps for flow and input power diagrams (page 42)

COVER END

See **DT6C** Single Pumps for flow and input power diagrams (page 42)





TRIPLE PUMPS DT6DCC - DIMENSIONS

DIMENSIONS IN MILLIMETERS. 1" = 25,4 mm

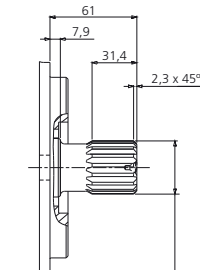
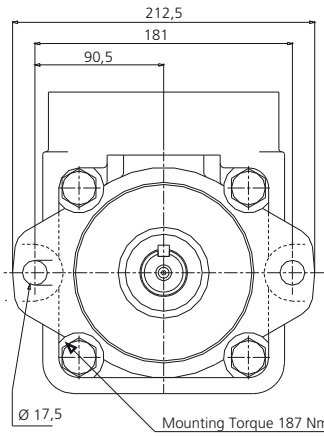

Shaft Code 4

SAE CC Splined shaft
1-J498b 12/24 d.p. -
17 Teeth
30° Pressure angle

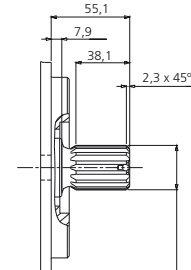

Shaft Code 3

SAE C Splined shaft
1-J498b 12/24 d.p. -
14 Teeth
30° Pressure angle

| Pump | Shaft Torque limits (cc/rev x bar) | | | |
|----------------|------------------------------------|----------------------|------------|----------------------|
| | Shaft Code | V x P max (P1+P2+P3) | Shaft Code | V x P max (P1+P2+P3) |
| DT6DCC | 1 | 43240 | 3 | 61200 |
| DT6DCCM | 2 | 66500 | 4 | 66500 |

| Alternate Ports | | | | |
|-----------------|------------|------|------|------|
| Orifice | Code | A | B | C |
| P3 | 00* | 52,4 | 26,2 | 25,4 |
| P3 | 01* | 47,6 | 22,1 | 19,0 |

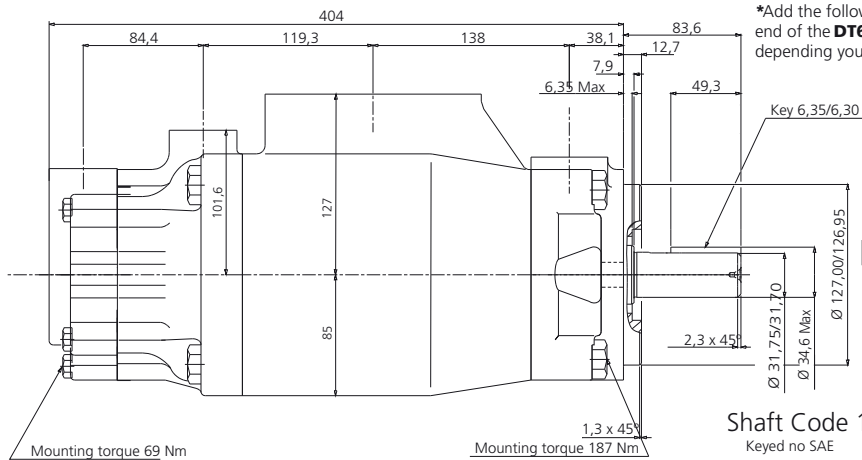

Shaft Code 1

Keyed no SAE

*Add the following numbers at the end of the **DT6DCC** reference depending your option.

| | Code 00 | Code 01 |
|----|---------|---------|
| P3 | 1" | 3/4" |

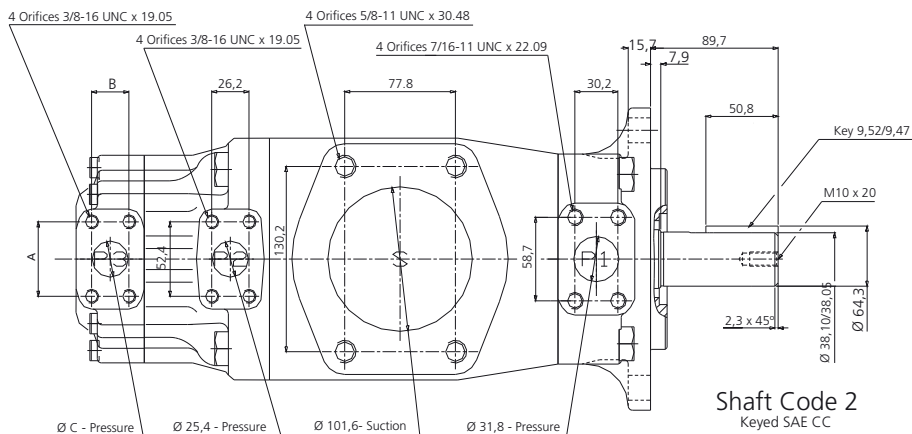

Shaft Code 2

Keyed SAE CC

4 Orifices 3/8-16 UNC x 19.05
4 Orifices 3/8-16 UNC x 19.05
4 Orifices 7/16-11 UNC x 22.09

Ø C - Pressure Ø 25,4 - Pressure Ø 101,6 - Suction Ø 31,8 - Pressure



DT6EDC - OPERATING CHARACTERISTICS

SHAFT END SECTION

| FLOW | | | | | | | | | | SPEED (rpm) | | PRESSURE (bar) | | |
|---------------------|-----|-----|-----|-----|-----|-----|-----|-----|--|-------------|------|----------------|-----------|---------|
| Lts/min.at 1000 rpm | 132 | 142 | 156 | 165 | 197 | 213 | 227 | 270 | | | Min. | Máx. | Intermit. | Contin. |
| Gal/min.at 1200 rpm | 42 | 45 | 50 | 52 | 62 | 66 | 72 | 85 | | | 500 | 2200* | 240 | 210 |

* See page 41 for further information about speed & pressure.

MIDDLE SECTION

| FLOW | | | | | | | | | | | SPEED (rpm) | | PRESSURE (bar) | | |
|---------------------|----|----|----|----|----|-----|-----|-----|-----|-----|-------------|------|----------------|-----------|---------|
| Lts/min.at 1000 rpm | 48 | 66 | 80 | 90 | 98 | 111 | 120 | 136 | 146 | 158 | 191 | Min. | Máx. | Intermit. | Contin. |
| Gal/min.at 1200 rpm | 14 | 20 | 24 | 28 | 31 | 35 | 38 | 42 | 45 | 50 | 61 | 500 | 2500* | 240 | 210 |

* See page 41 for further information about speed & pressure.

COVER END SECTION

| FLOW | | | | | | | | | | | | SPEED (rpm) | | PRESSURE (bar) | | | |
|---------------------|----|----|----|----|----|----|----|----|----|----|----|-------------|-----|----------------|-------|-----------|---------|
| Lts/min.at 1000 rpm | 11 | 17 | 21 | 26 | 34 | 37 | 46 | 58 | 64 | 70 | 79 | 89 | 100 | Min. | Máx. | Intermit. | Contin. |
| Gal/min.at 1200 rpm | 3 | 5 | 6 | 8 | 10 | 12 | 14 | 17 | 20 | 22 | 25 | 28 | 31 | 500 | 2800* | 275 | 240* |

* See page 41 for further information about speed & pressure.

DT6EDC - FLOW & INPUT POWER DIAGRAMS

SHAFT END

See **DT6E** Single Pumps for flow and input power diagrams (page 46)

MIDDLE BODY

See **DT6D** Single Pumps for flow and input power diagrams (page 44)

COVER END

See **DT6C** Single Pumps for flow and input power diagrams (page 42)





TRIPLE PUMPS DT6EDC/DT6EDCM - DIMENSIONS

DIMENSIONS IN MILLIMETERS. 1" = 25,4 mm

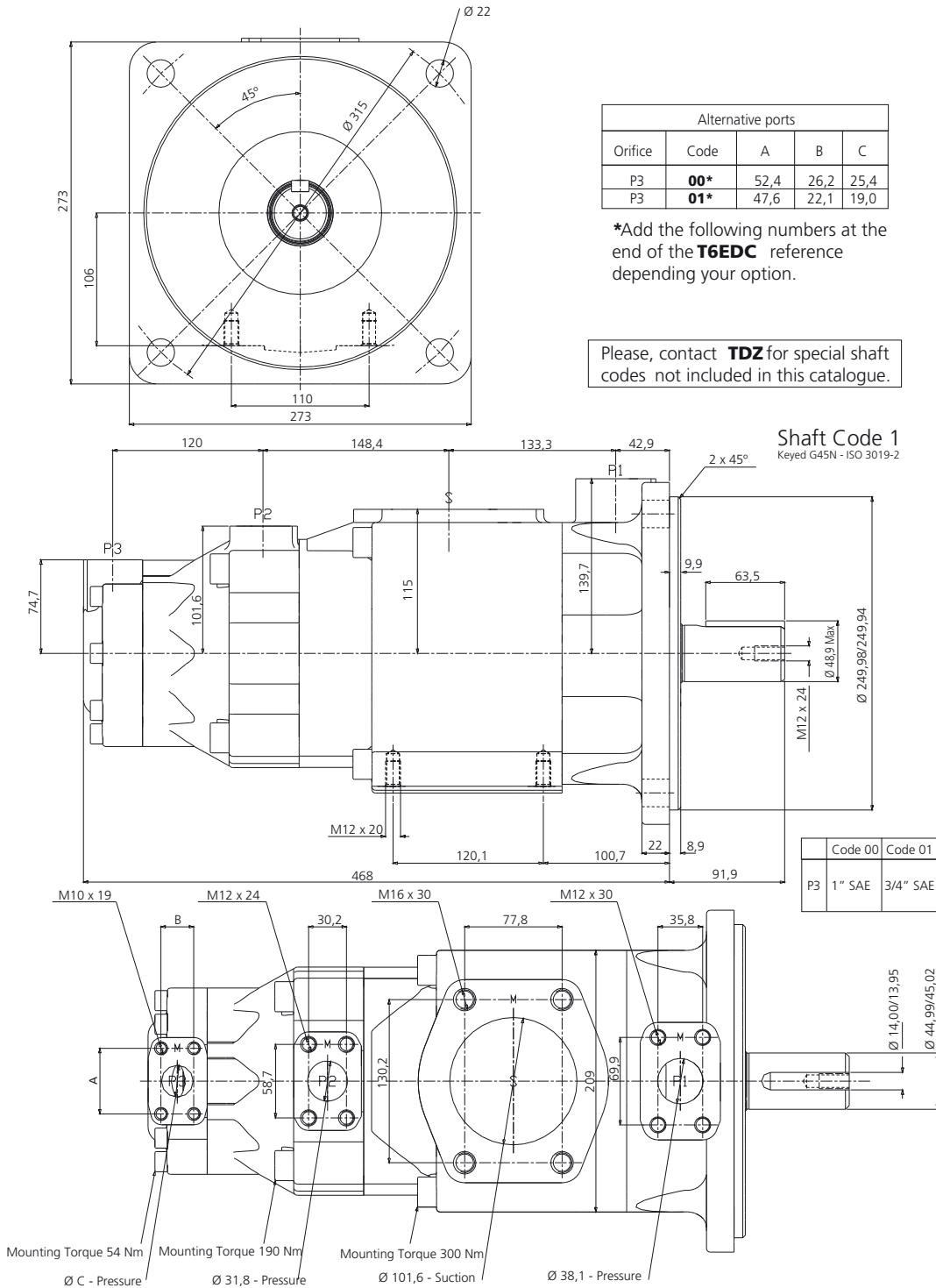



T6G SINGLE & DOUBLE VANE PUMPS 4 HOLES ISO FLANGE

For direct mounting in Power Take Off

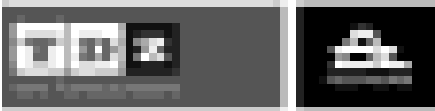

DT6GC SINGLE & DT6GCC DOUBLE VANE PUMPS ORDERING CODE

T6GC(C) - B22(B22) - 6 - R - 00 - A - 1 - 00 - *

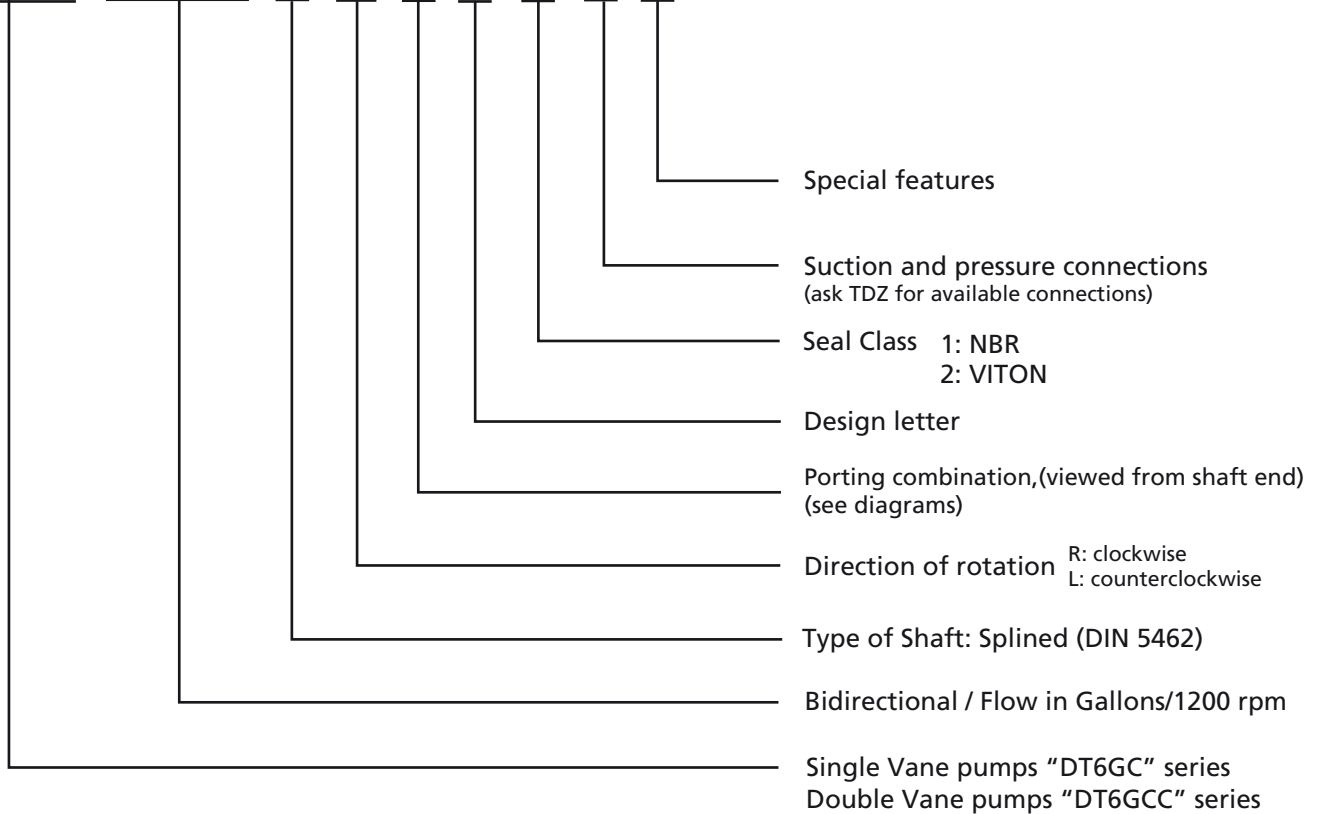



DT6GC & DT6GCC PORTING COMBINATION

DT6GC

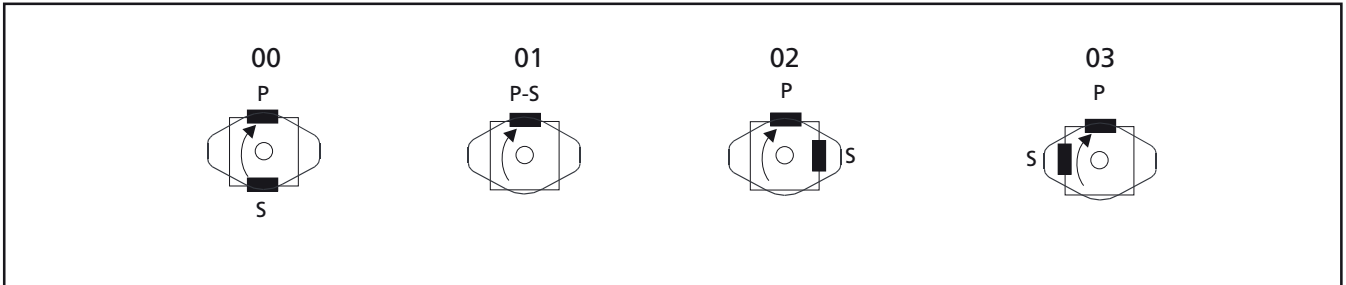

DT6GCC

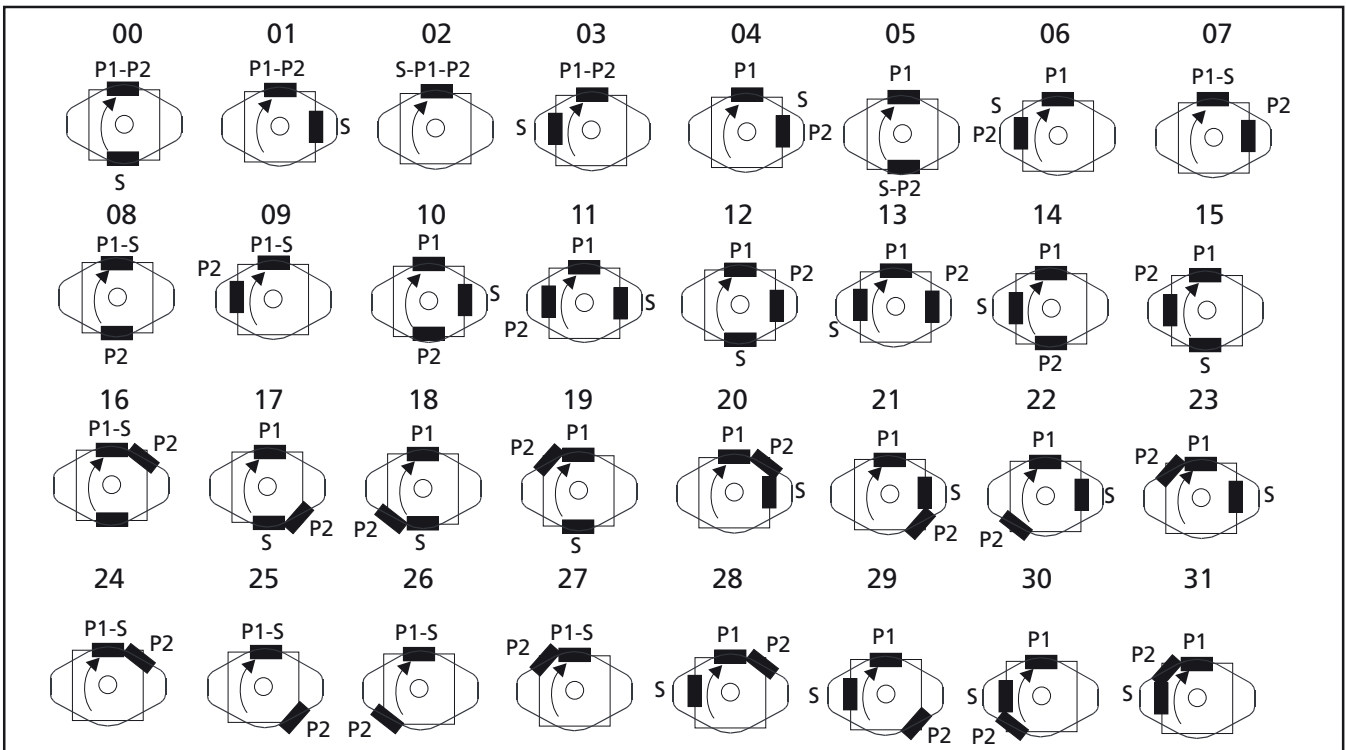

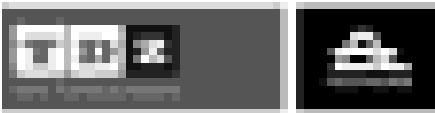

DT6GC OPERATING CHARACTERISTICS

| FLOW | | | | | | | | | | SPEED (rpm) | | PRESSURE (bar) | | WEIGHT |
|---------------------|----|----|----|----|----|----|----|----|----|-------------|-------|----------------|---------|--------|
| Lts/min.at 1000 rpm | | | | | | | | | | Mín. | Máx. | Intermit. | Contin. | (Kgs.) |
| 11 | 17 | 21 | 26 | 34 | 37 | 46 | 58 | 64 | 70 | 700 | 2800* | 275 | 240* | 18 |
| Gal/min.at 1200 rpm | | | | | | | | | | | | | | |
| 3 | 5 | 6 | 8 | 10 | 12 | 14 | 17 | 20 | 22 | | | | | |

* See page 41 for further information about speed & pressure.

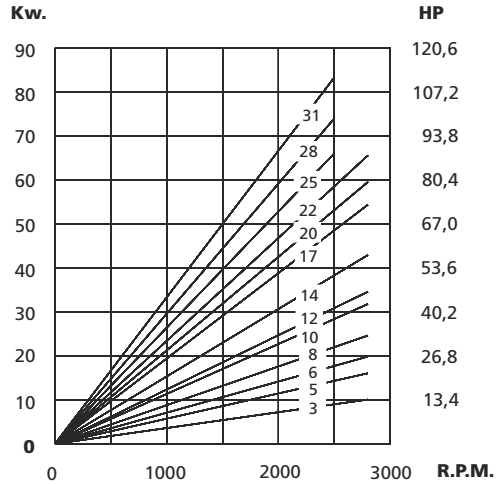
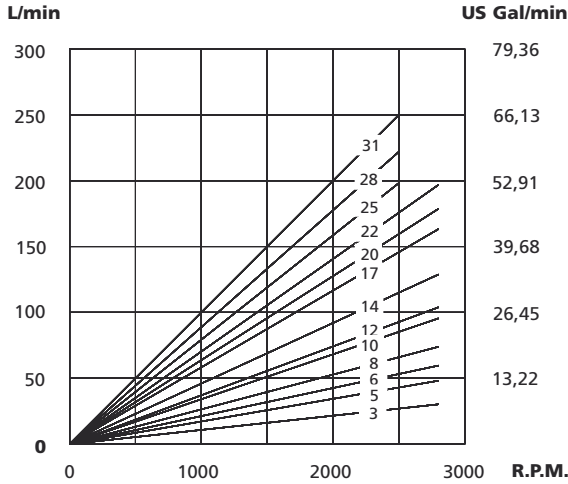

Theoretical Flow (0 Bar)

Theoretical Input Power at 200 Bar

To calculate the real flow at a given operating pressure, subtract the internal leakage value for this pressure (see diagram below) from the theoretical flow. (See diagram above).

To calculate the theoretical input power at other pressures and speeds, use the formula:

$$P(Kw) = \frac{Q(L/min.) \times P(Bar)}{600}$$

Where Q is the theoretical flow (upper left diagram) and P the operating pressure.

To calculate the real input power, add to the theoretical power the hydromechanic power losses (see diagram below).

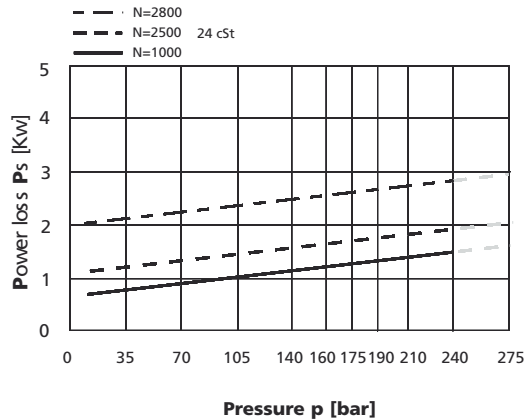
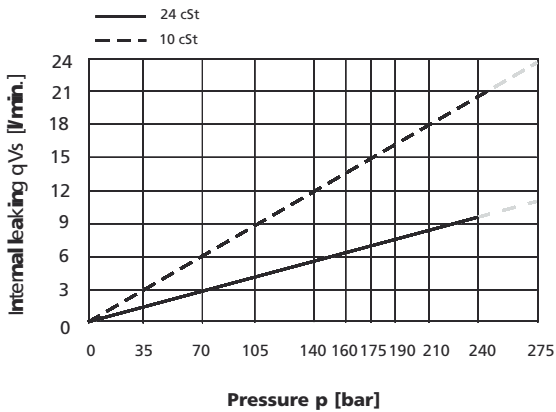

Do not operate pump more than 5 seconds at any speed or viscosity if internal leakage is more than 50 % of theoretical flow





DT6GC SINGLE VANE PUMPS

DIMENSIONS - SINGLE VANE PUMPS DT6GC

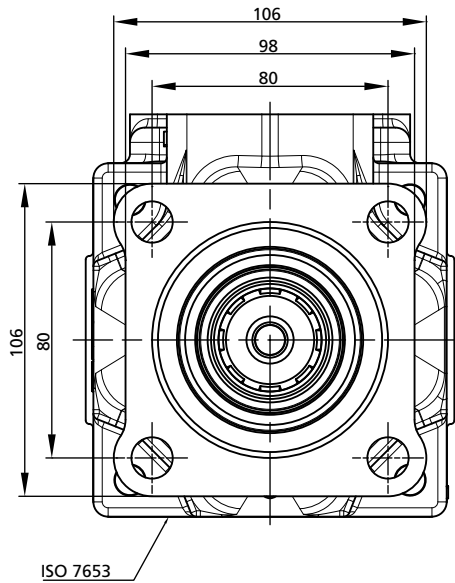

DIMENSIONS IN MILLIMETERS. 1" = 25,4 mm

| | ∅D1 | ∅D3 | L1 | L2 |
|-------|------------|--------------|-------|------|
| COVER | 1" 1/2 SAE | 1/2"-13H UNC | 69,85 | 35,7 |
| | 1" 1/2 SAE | M12 | 69,85 | 35,7 |

| | ∅D2 | ∅D4 | L3 | L4 |
|--------|----------|--------------|-------|-------|
| FLANGE | 1" SAE | 3/8"-16H UNC | 52,4 | 26,2 |
| | 1" SAE | M10 | 52,4 | 26,2 |
| | 1" BSP | _____ | _____ | _____ |
| | 3/4" BSP | _____ | _____ | _____ |

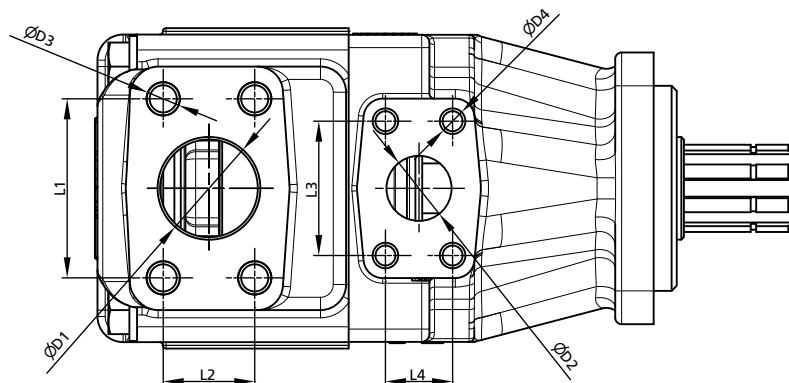
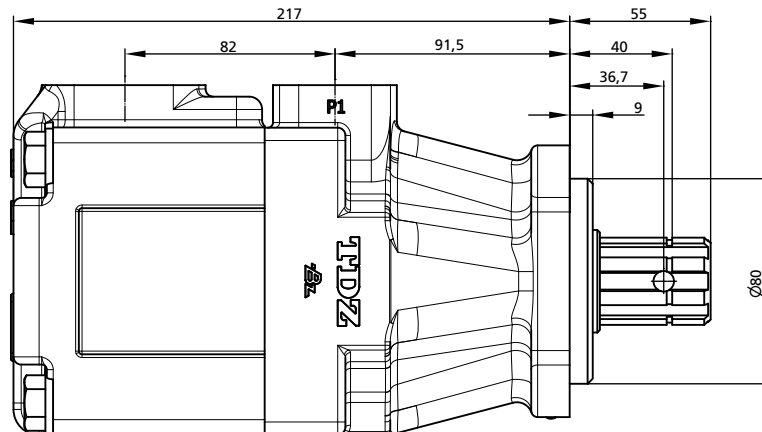



DOUBLE PUMPS DT6GCC - OPERATING CHARACTERISTICS

DATA SHEET

SHAFT END SECTION

| FLOW | | | | | | | | | | | SPEED (rpm) | | PRESSURE (bar) | | | | |
|---------------------|----|----|----|----|----|----|----|----|----|----|-------------|----|----------------|------|-------|-----------|---------|
| Lts/min.at 1000 rpm | 11 | 17 | 21 | 26 | 34 | 37 | 46 | 58 | 64 | 70 | 79 | 89 | 100 | Mín. | Máx. | Intermit. | Contin. |
| Gal/min.at 1200 rpm | 3 | 5 | 6 | 8 | 10 | 12 | 14 | 17 | 20 | 22 | 25 | 28 | 31 | 700 | 2800* | 275 | 240* |

* See page 41 for further information about speed & pressure.

COVER END SECTION

| FLOW | | | | | | | | | | | SPEED (rpm) | | PRESSURE (bar) | | | | |
|---------------------|----|----|----|----|----|----|----|----|----|----|-------------|----|----------------|------|-------|-----------|---------|
| Lts/min.at 1000 rpm | 11 | 17 | 21 | 26 | 34 | 37 | 46 | 58 | 64 | 70 | 79 | 89 | 100 | Mín. | Máx. | Intermit. | Contin. |
| Gal/min.at 1200 rpm | 3 | 5 | 6 | 8 | 10 | 12 | 14 | 17 | 20 | 22 | 25 | 28 | 31 | 700 | 2800* | 275 | 240* |

* See page 41 for further information about speed & pressure.

DT6GCC - FLOW & INPUT POWER DIAGRAMS

SHAFT END

See **DT6GC** Single Pumps for flow and input power diagrams (page 42)

COVER END

See **DT6GC** Single Pumps for flow and input power diagrams (page 42)





DT6GCC DOUBLE VANE PUMPS

DOUBLE PUMPS DT6GCC - DIMENSIONS - WEIGHT: 29 Kg

DIMENSIONS IN MILLIMETERS. 1" = 25,4 mm

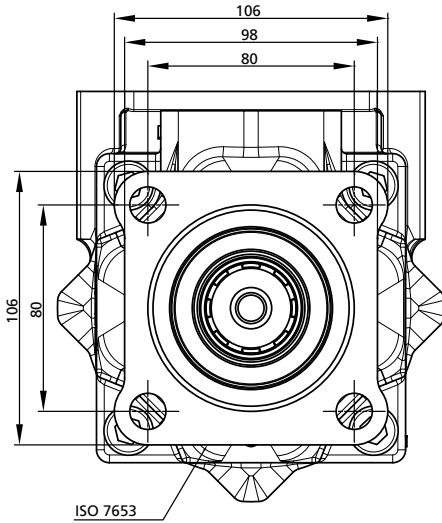

| | ØD1 | ØD4 | L1 | L2 |
|-------|----------|--------------|-------|------|
| COVER | 1" SAE | 3/8"-16H UNC | 69,85 | 35,7 |
| | 1" SAE | M10 | 69,85 | 35,7 |
| | 3/4" SAE | 3/8"-16H UNC | 47,6 | 22,2 |
| | 3/4" SAE | M10 | 47,6 | 22,2 |

| | ØD2 | ØD5 | L3 | L4 |
|---------|------------|--------------|-------|------|
| HOUSING | 2" 1/2 SAE | 1/2"-13H UNC | 88,9 | 50,8 |
| | 3" SAE | 5/8"-16H UNC | 106,4 | 61,9 |
| | 2" 1/2 SAE | M12 | 88,9 | 50,8 |
| | 3" SAE | M16 | 106,4 | 61,9 |

| | ØD3 | ØD6 | L5 | L6 |
|--------|----------|--------------|------|------|
| FLANGE | 1" SAE | 3/8"-16H UNC | 52,4 | 26,2 |
| | 1" SAE | M10 | 52,4 | 26,2 |
| | 1" BSP | | | |
| | 3/4" BSP | | | |

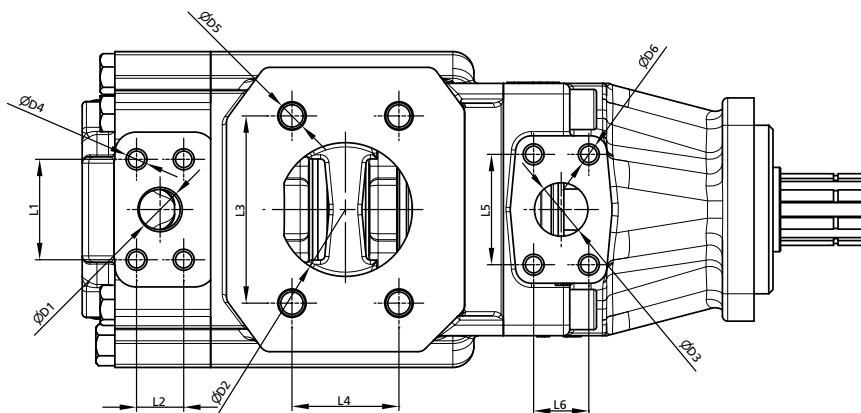
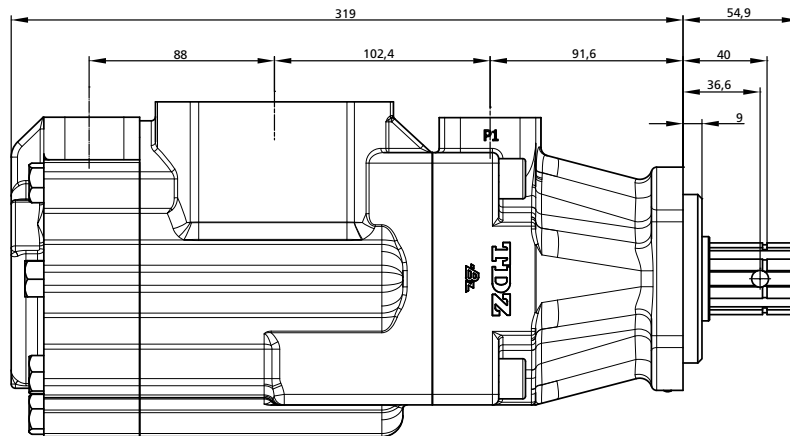



SINGLE VANE PUMPS WITH FLOW CONTROL & PRIORITY VALVE

-VC10F -VC10P

-VC20F -VC20P

POWER STEERING VANE PUMPS

-VCTM42



SINGLE VANE PUMPS VC10&VC20 WITH FLOW CONTROL & PRIORITY VALVE

VC ORDERING CODE

DATA SHEET

$$\frac{VC20}{1} \frac{(F)}{2} - \frac{1P11S}{3456} - \frac{1C}{789} \frac{(8)}{10} - \frac{(H)}{11} - \frac{(L)}{11}$$

1-Model

VC10, VC20

2-Cover

Omit - Standard Cover

F - Flow Control Cover

P - Priority Valve Cover

3-Mounting

1 - 2 - Bolt Flange

4-Inlet Port Connection

S - 1.3125"-12 Str.thd. (VC10)

- 1.625"-12 Str.thd. (VC20)

P - 1.00" NPT (VC10)

- 1.25" NPT (VC20)

B - 1.00" BSP (VC10)

- 1.25" BSP (VC20)

5-Delivery (USgpm at 1200 rpm)

VC10-1, 2, 3, 4, 5, 6, 7

VC20-5, 6, 7, 8, 9, 10, 11, 12, 13

6-Outlet Port Connection

VC10F, VC10P, VC20F and VC20P

S - 0.750"-16 Str.thd. for outlet
and 1.0625"-12 Str. thd. For tank port (VC20F)

P - 0.750"-16 Str.thd. for outlet and
0.500" NPT for tank port (VC10F and VC20F)

T - 0.750"-16 Str.thd. for outlet and tank port (VC10F)

- 0.750"-16 Str.thd. for primary outlet and
tank port 0.875"-14 Str.thd.for secondary outlet (VC20P)

K - 0.5625"-18 Str.thd. for primary outlet and
tank port and 0.750"-16 Str.thd.for secondary outlet (VC10P)

T - 0.750"-16 Str.thd. for outlet and
0.750"-16 Str.thd. for tank port (VC20F)

7-Shaft

1 - Straight keyed

3 - Threaded with woodruff key

6 - Woodruff key stub (VC20 only)

11 - Splined

12 - Splined (VC10 only)

15 - Splined (VC20 only)

38 - Splined (VC20 only)

123 - Threaded with woodruff key

8-Outlet Port Position

(Viewed from cover end)

A - Opposite inlet

B - 90° CCW from inlet

C - Inline with inlet

D - 90° CW from inlet

9-Flow rate Setting for Flow control and

Priority Valve Cover L/min (USgpm)

2 - 7.6 (2) 6 - 22.7 (6)

3 - 11.4 (3) 7 - 26.5 (7)

4 - 15.2 (4) 8 - 30.3 (8)

5 - 19.0 (5)

10-Pressurer Setting for Flow control and

Priority Valve Cover bar (psi)

A - 17 (250) F - 103 (1500)

B - 34 (500) G - 121 (1750)

C - 52 (750) H - 138 (2000)

D - 69 (1000) J - 155 (2200)

E - 86 (1250) K - 172 (2500)

11-Shaft Rotation

(Viewed from shaft end)

Omit - Turn right

L - Turn left





SINGLE VANE PUMPS VC10&VC20 WITH FLOW CONTROL & PRIORITY VALVE

VC10F&P INSTALLATION DIMENSIONS

VC10P

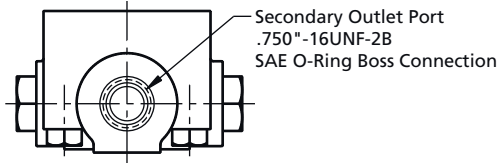

| Delivery @ 1200 rpm & 7 bar (100 psi) | Dimension | |
|--|--------------|-------------|
| | A | B |
| 1, 2, 3 | 130.0 (5.12) | 84.8 (3.34) |
| 4, 5 | 136.4 (5.37) | 91.2 (3.59) |
| 6, 7 | 141.5 (5.57) | 96.3 (3.79) |

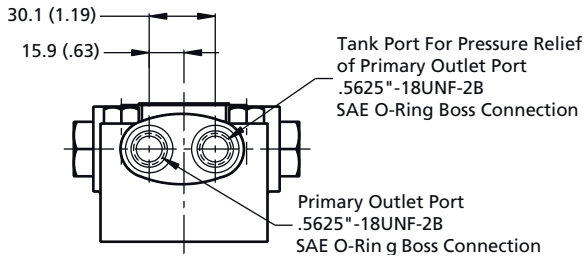
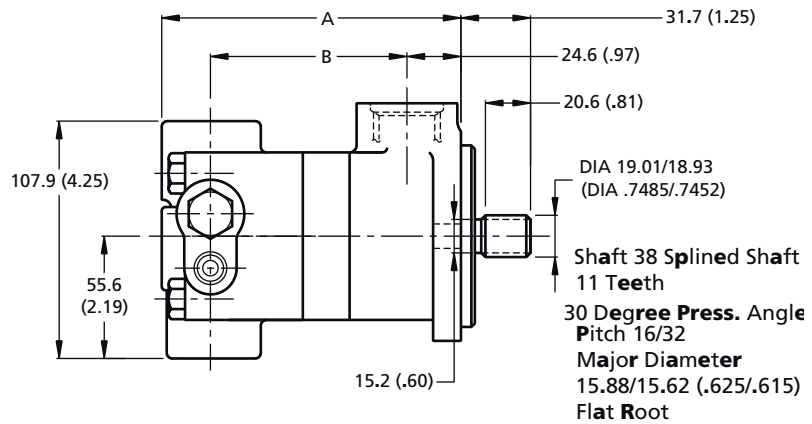
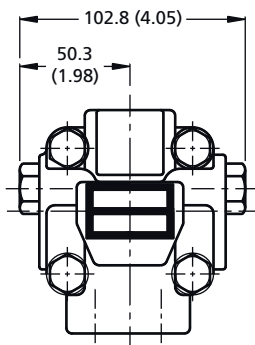

VC10F

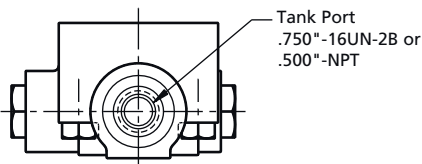

| Delivery @ 1200 rpm & 7 bar (100 psi) | Dimension | |
|--|--------------|-------------|
| | A | B |
| 1, 2, 3 | 128.8 (5.07) | 84.8 (3.34) |
| 4, 5 | 135.1 (5.32) | 91.2 (3.59) |
| 6, 7 | 140.2 (5.52) | 96.3 (3.79) |

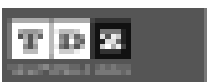
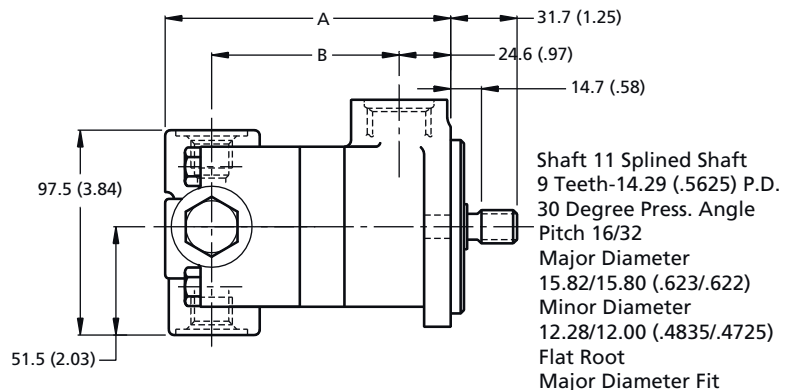
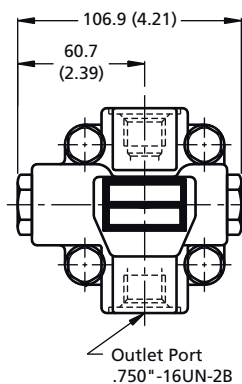

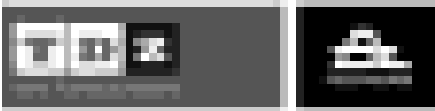

SINGLE VANE PUMPS VC10&VC20 WITH FLOW CONTROL & PRIORITY VALVE

VC20F&P INSTALLATION DIMENSIONS

DATA SHEET

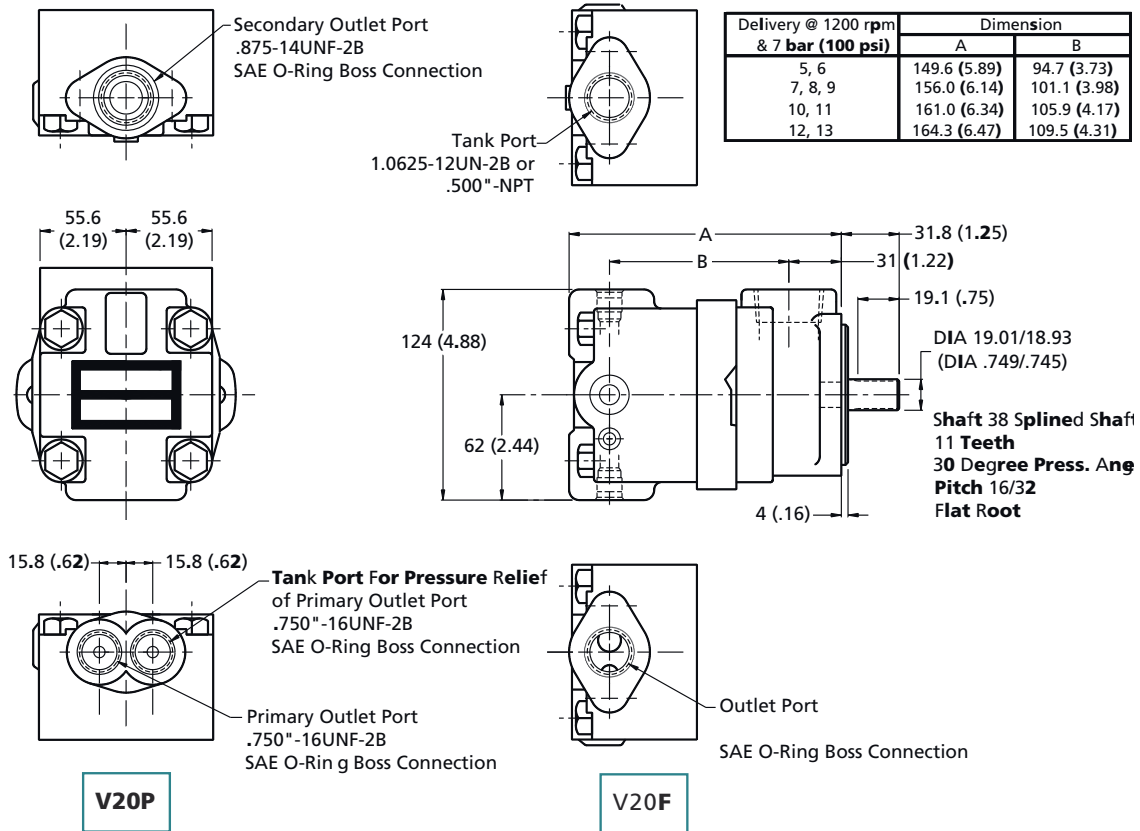

SHAFT OPTIONS FOR VC10 SERIES AND VC20 SERIES

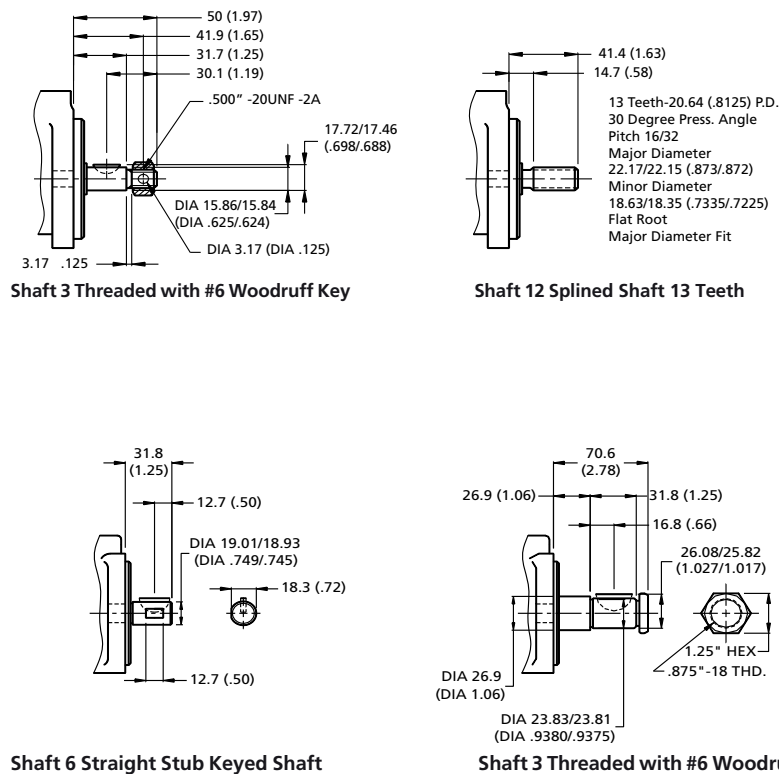



SINGLE VANE PUMPS VC10&VC20 WITH FLOW CONTROL & PRIORITY VALVE

VC10 AND VC20 PERFORMANCE CHARACTERISTICS

Based on viscosity 32 cSt (150 SSU) oil at 49°C (120°F) and pump inlet at 0 PSIG (14.7 PSIA)

VC10F, VC20F SINGLE PUMPS

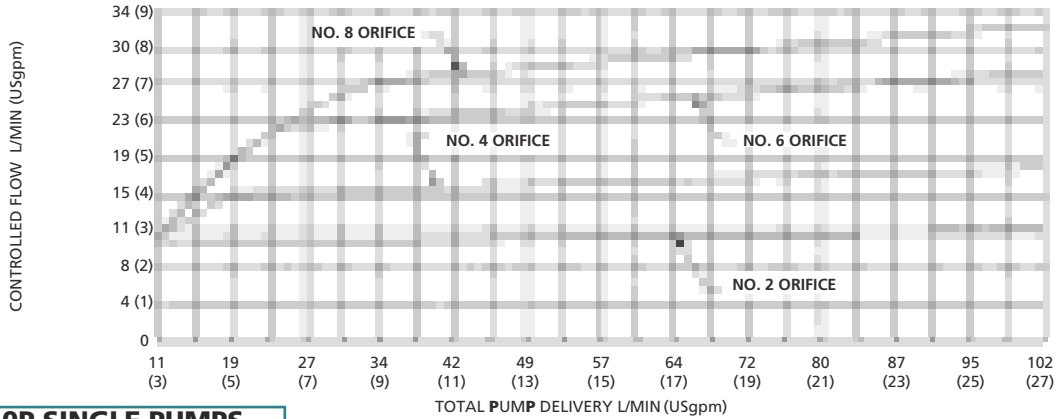

VC10P SINGLE PUMPS

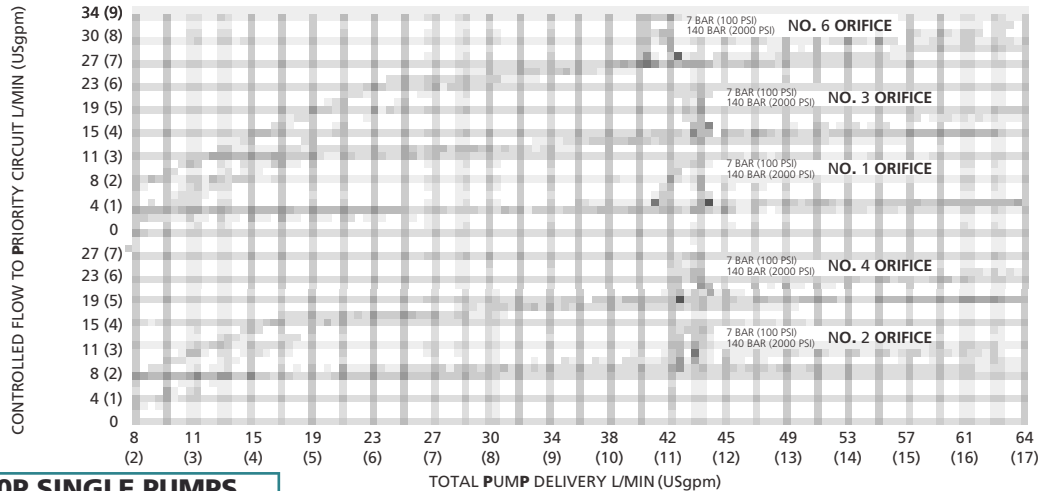

VC20P SINGLE PUMPS

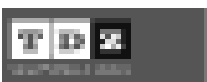
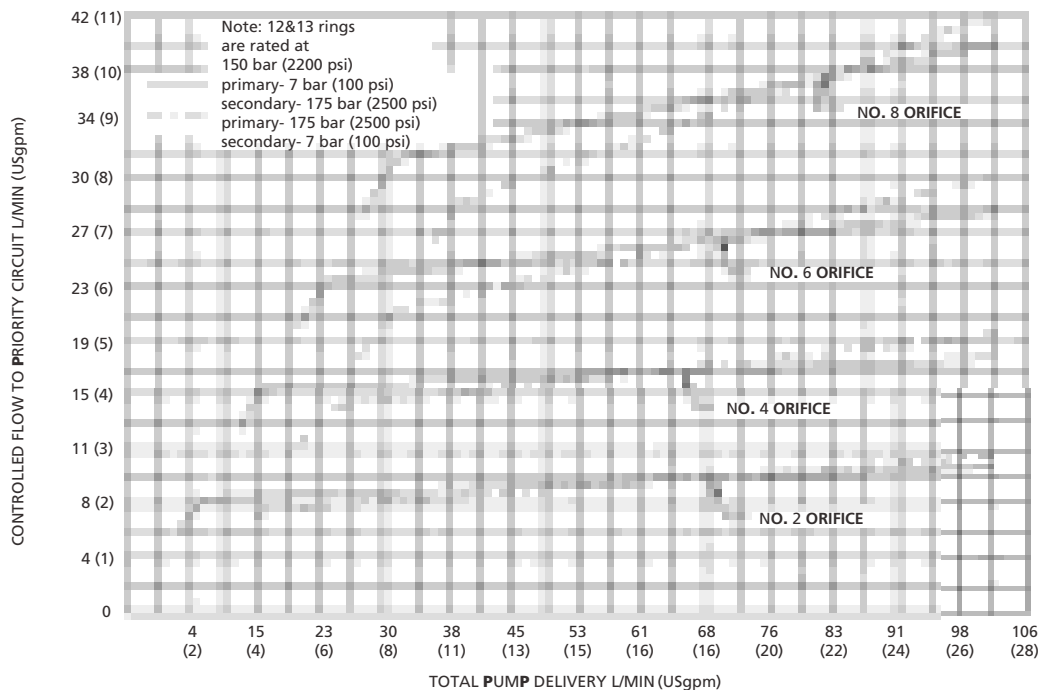



POWER STEERING PUMP

VCTM42 ORDERING CODE

VCTM42 20 15 20 F 11 L 1
 1 2 3 4 5 6 7 8

1-Model

VCTM42

2-Delivery (USgpm at 1200 rpm & 7 bar)

10 - 1.0 US gpm 40 - 4.0 US gpm
 15 - 1.5 US gpm 50 - 5.0 US gpm
 20 - 2.0 US gpm 60 - 6.0 US gpm

3-Controlled Flowrate (at 1500 rpm & 7 bar)

US gpm (L/min)
 15 - 1.5 (6.0) 50 - 5.0 (19.0)
 20 - 2.0 (8.0) 55 - 5.5 (21.0)
 25 - 2.5 (9.5) 60 - 6.0 (23.0)
 30 - 3.5 (13.0) 65 - 6.5 (25.0)
 40 - 4.0 (15.0) 70 - 7.0 (26.5)
 45 - 4.5 (17.0) 75 - 7.5 (28.0)

4-Relief Valve Cracking Pressure Setting

psi (bar)
 05 - 500 (35) 15 - 1500 (100)
 07 - 750 (52) 17 - 1700 (120)
 10 - 1000 (70) 20 - 2000 (140)
 12 - 1250 (86)

5-Filter for Tank

no code - Standard baffle without filter
 F - With filter

6-Tank or Manifold

NO - Without Tank
 11 - With 115 cu.in. (1884 cc.) Tank
 07 - With 70 cu.in. (1147 cc.) Tank
 MA - Manifold without bypass tube
 MF - Cast iron manifold with bypass tube
 ME - Cast iron manifold with no bypass tube
 MB - Manifold with bypass tube

7-Shaft Rotation

(Viewed from shaft end)
 no code - Turn right
 L - Turn left

8-Shaft

1 - Threaded

VCTM42 CHARACTERISTICS

| TYPE | RING SIZE DELIVERY AT 1200 r/m & 7 bar (100 psi) Usgpm | GEOMETRIC DISPLACEMENT cm ³ /r | MAXIMUM SPEED | | | MAXIMUM PRESSURE bar | WEIGHT kg |
|--------|--|---|--------------------|-----------------------|-----------------------|----------------------|-----------|
| | | | at 7 bar (100 psi) | at 100 bar (1500 psi) | at 140 bar (2000 psi) | | |
| | | | rpm | rpm | rpm | | |
| VCTM42 | 1 | 3.4 | 7000 | 5000 | 4250 | 140 | 6.4 |
| | 1.5 | 5.0 | 7000 | 4500 | 4000 | | |
| | 2 | 6.2 | 7000 | 4200 | 3800 | | |
| | 4 | 12.9 | 7000 | 2800 | 2800 | | |
| | 5 | 15.7 | 6000 | 2500 | 2300 | | |
| | 6 | 19.3 | 5000 | 2500 | 2000 | | |



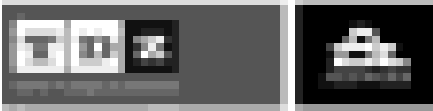

VCTM42 INSTALLATION DIMENSIONS

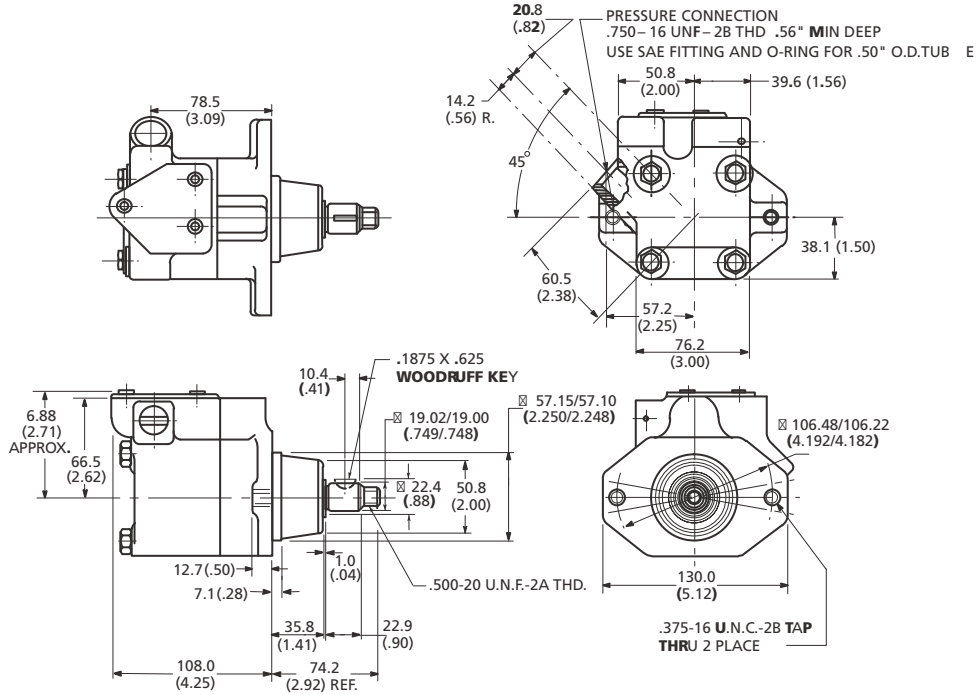

VCTM42 - TANK DIMENSIONS

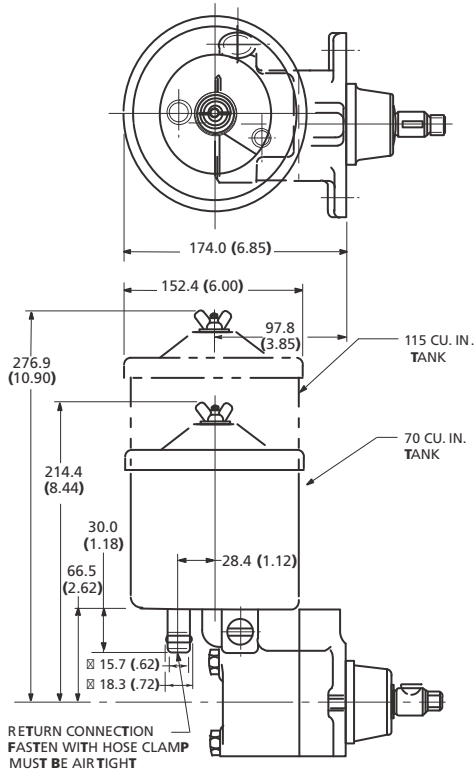

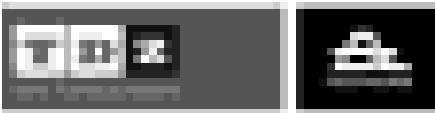

VCTM42 INSTALLATION DIMENSIONS

DATA SHEET

DIMENSIONS IN MILLIMETERS. 1" = 25,4 mm

MANIFOLD FOR POWER STEERING PUMPS

USE .621 ID. HOSE
FASTEN WITH
HOSE CLAMP
MUST BE AIR TIGHT

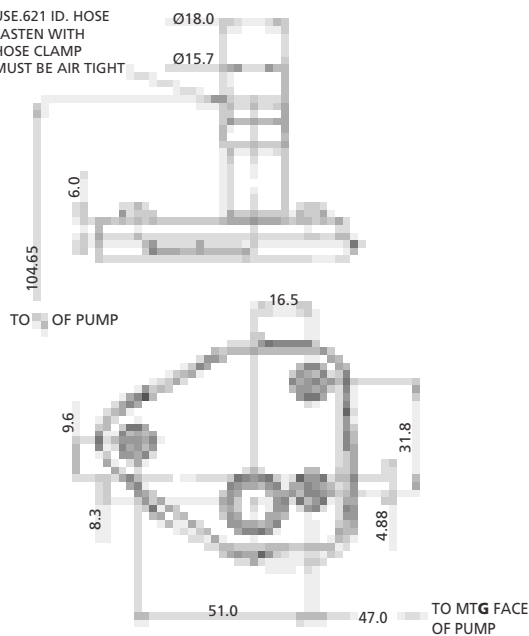

USE .621 ID. HOSE
FASTEN WITH
HOSE CLAMP
MUST BE AIR TIGHT

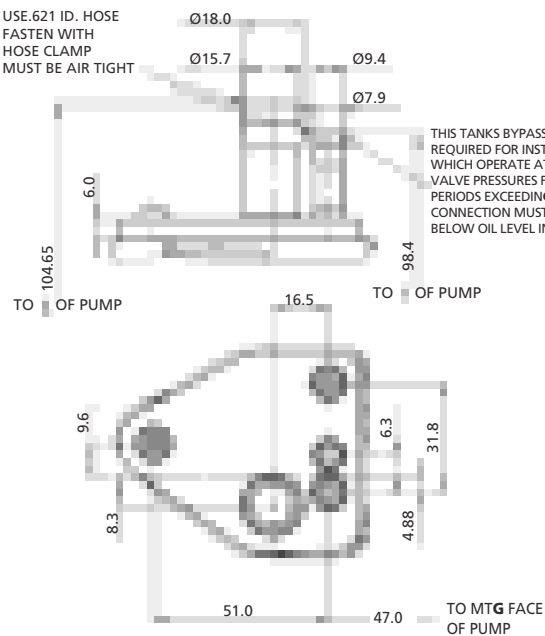

THIS TANKS BYPASS CONN.JS
REQUIRED FOR INSTALLATIONS
WHICH OPERATE AT PUMP RELIEF
VALVE PRESSURE FOR
PERIODS EXCEEDING 15 SECONDS.
CONNECTION MUST BE MADE
BELOW OIL LEVEL IN RESERVOIR.

"MA" Manifold

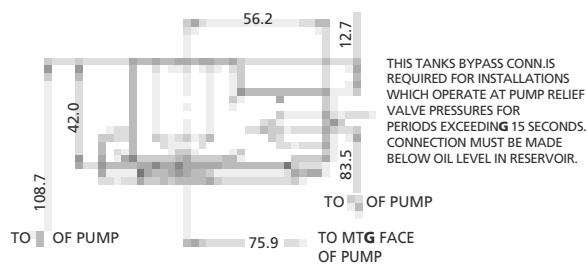

THIS TANKS BYPASS CONN.JS
REQUIRED FOR INSTALLATIONS
WHICH OPERATE AT PUMP RELIEF
VALVE PRESSURE FOR
PERIODS EXCEEDING 15 SECONDS.
CONNECTION MUST BE MADE
BELOW OIL LEVEL IN RESERVOIR.

"MB" Manifold

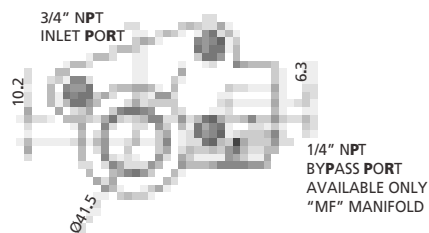
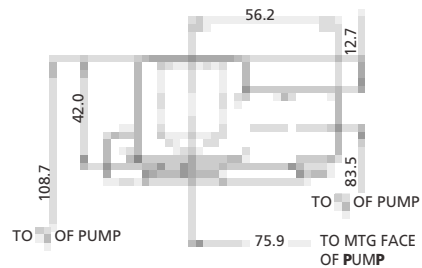

"MF" Manifold

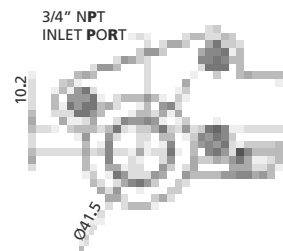

"ME" Manifold





VCTM42 PERFORMANCE CHARACTERISTICS

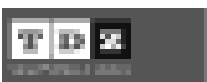
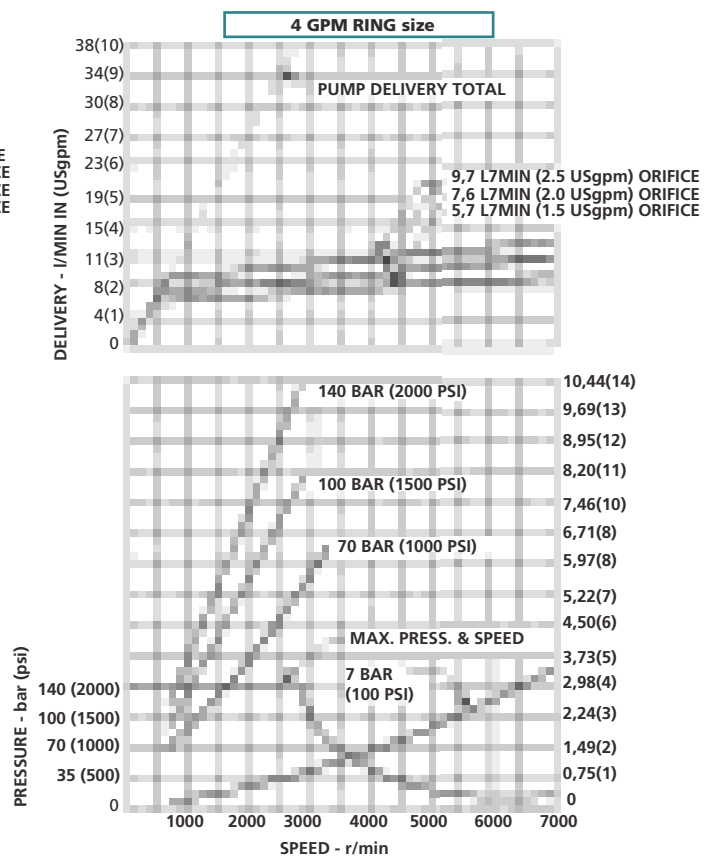
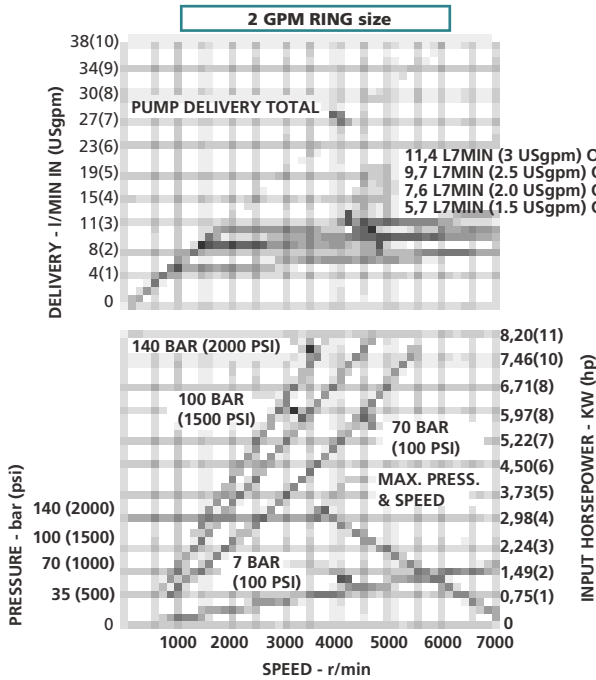
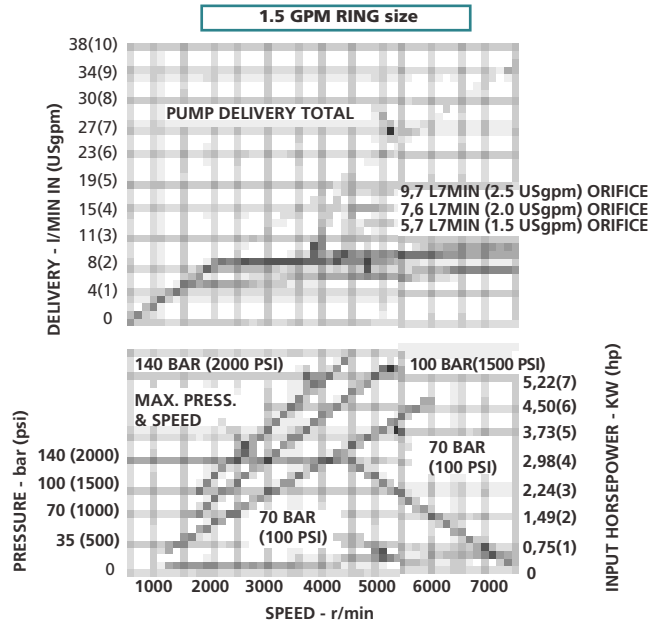
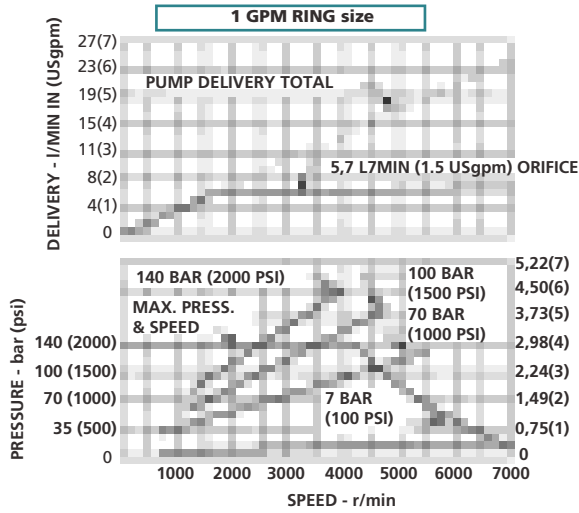

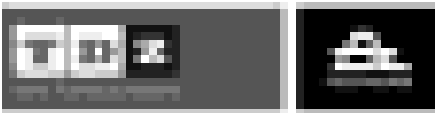

VCTM42 PERFORMANCE CHARACTERISTICS

DATA SHEET

5 GPM RING size

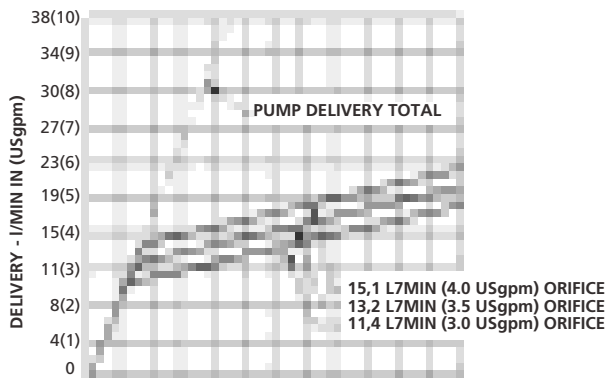

6 GPM RING size

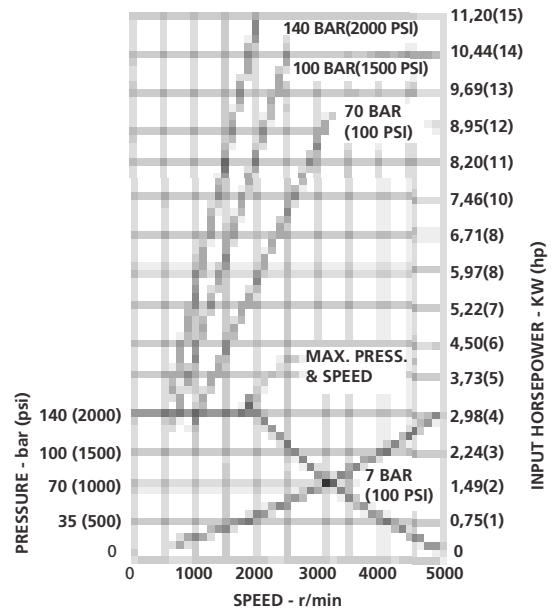
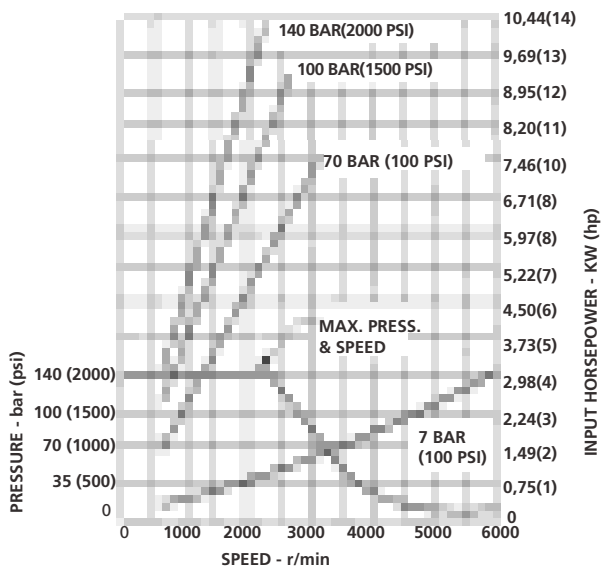
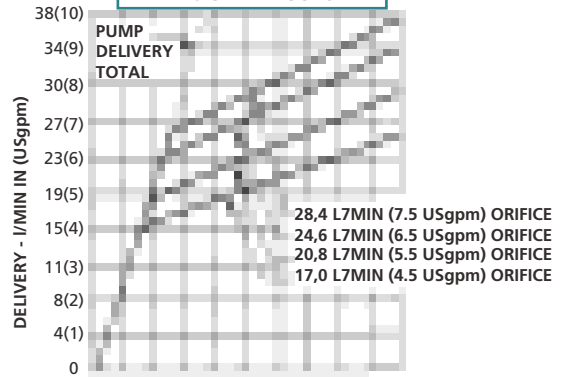

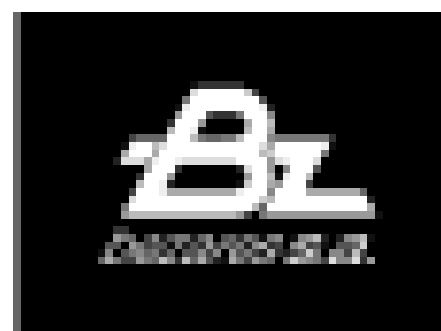

VANE MOTORS

MD4C & MH4D

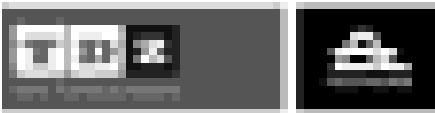

MD4C - ORDERING CODE & OPERATING CHARACTERISTICS

DATA SHEET

MD4C 075 1 N 00 C 1 02 ..

Series external drain

Nominal flow (nominal torque)

| | |
|-----|---------------|
| 024 | (0,39 Nm/bar) |
| 027 | (0,45 Nm/bar) |
| 031 | (0,55 Nm/bar) |
| 043 | (0,74 Nm/bar) |
| 055 | (0,93 Nm/bar) |
| 067 | (1,13 Nm/bar) |
| 075 | (1,27 Nm/bar) |
| 100 | (1,56 Nm/bar) |

Type of shaft

- 1= Keyed (SAE B)
- 2= Keyed (no SAE)
- 3= Splined (SAE B)
- 9= Special (non SAE)

Rotation

N = Bi-direccional

View from shaft end:

CW Rotation: A= INLET
B= OUTLET

CCW Rotation: A= OUTLET
B= INLET

Modification

Port connections

- 01 = Threaded Port
1" 5/16 UNF
9/16"-18 UNF Drain
- 02 = 4 Bolt Flange
3/8"-16 UNC Threaded
9/16"-18 UNF Drain
- 03 = Threaded Port 3/4" BSP
3/8" BSP Drain
- 04 = 4 Bolt Flange
3/8-16 UNC Threaded
3/8" BSP Drain
- M4 = 4 Bolt Flange
Metric Threaded M10x20
3/8" BSP Drain

Seal Class

- 1 = NBR 5= Viton

Desing letter

Porting combination

- 01 = Side ports (right/left)
- 02 = Side ports (up/down)

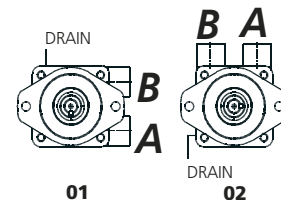

INTERNAL LEAKAGE

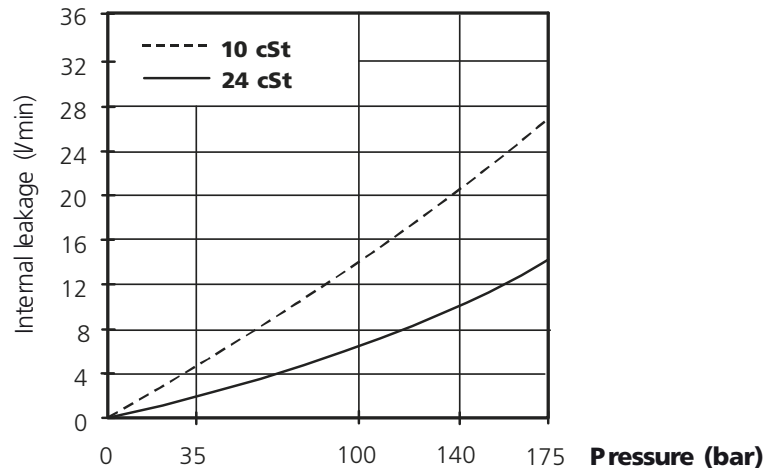



DIMENSIONS, SHAFTS & PORT CONNECTIONS - MD4C

DIMENSIONS IN MILLIMETERS. 1" = 25,4 mm

PORT CONNECTIONS

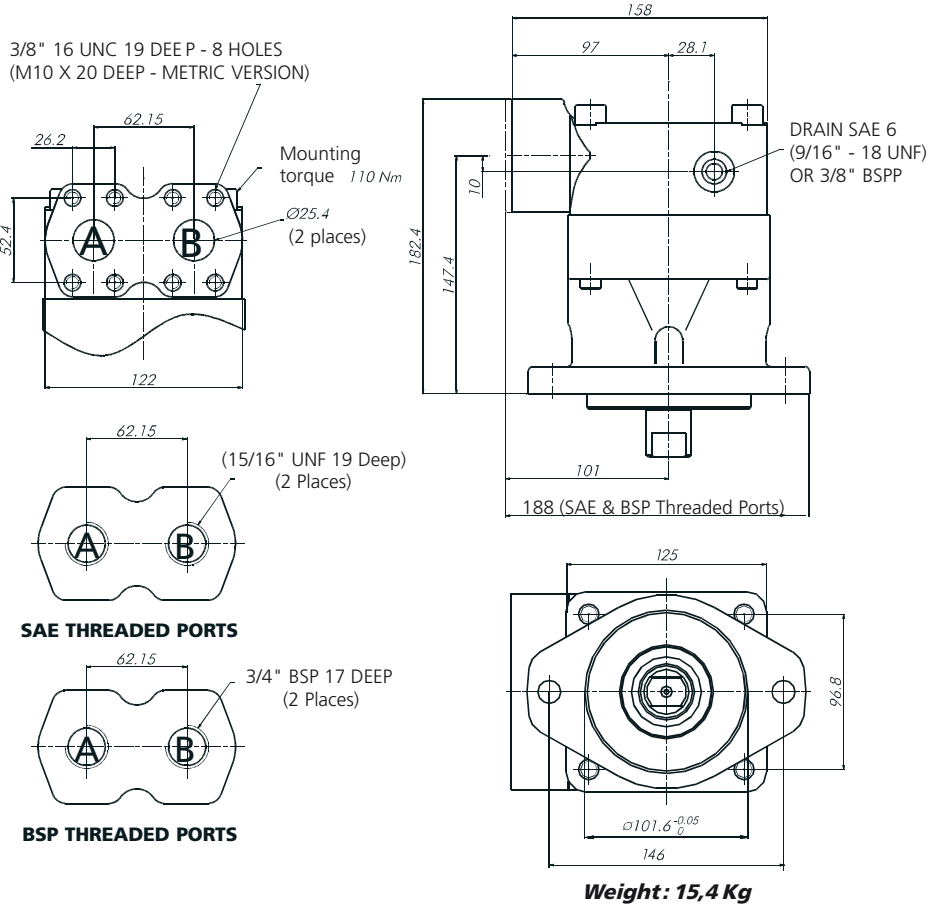

SHAFT TYPE

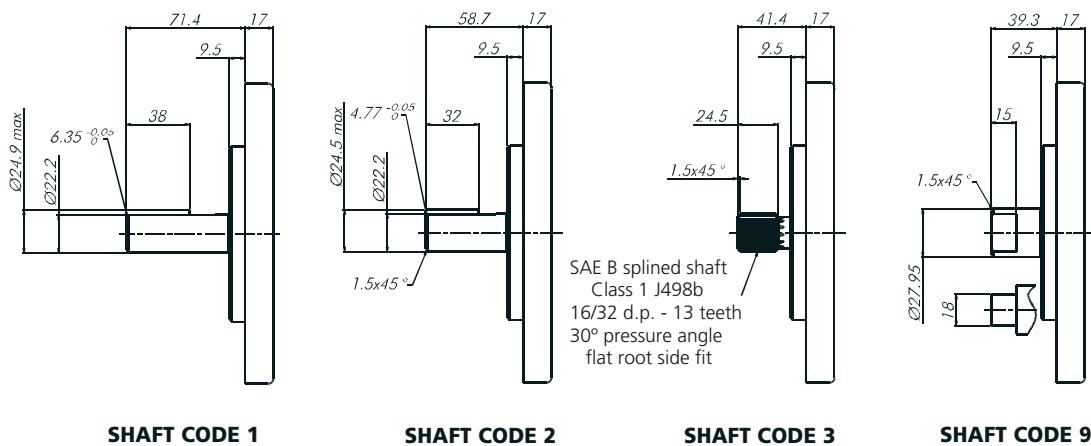

Enquire about other types of shafts

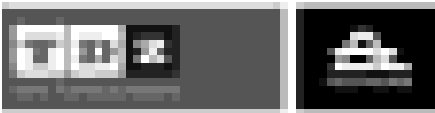

PERFORMANCE CURVES - OIL VISCOSITY : 24 CST (45°) - MD4C

DATA SHEET

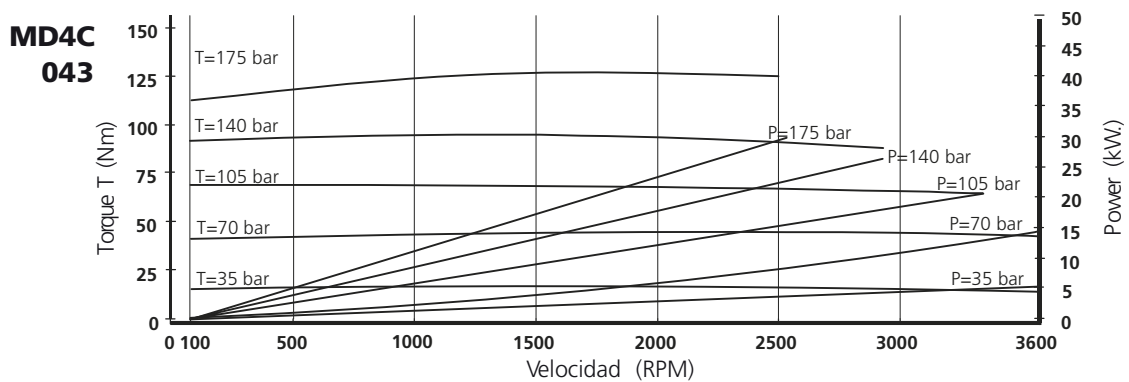
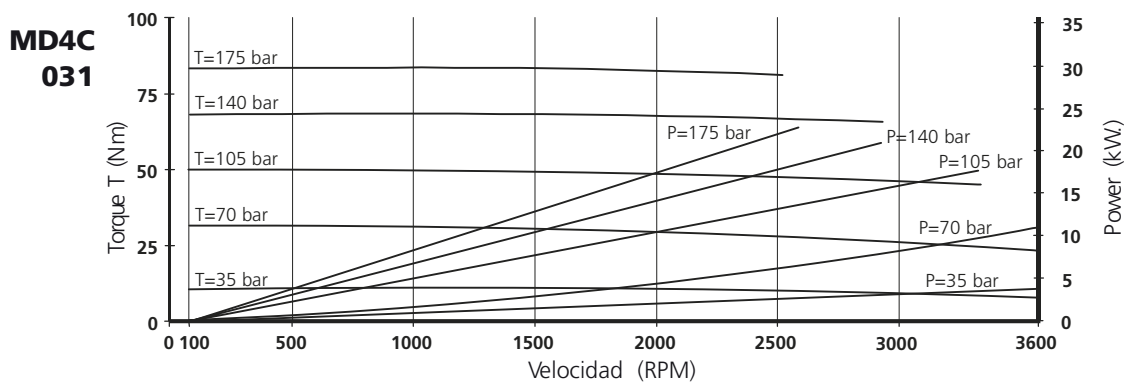
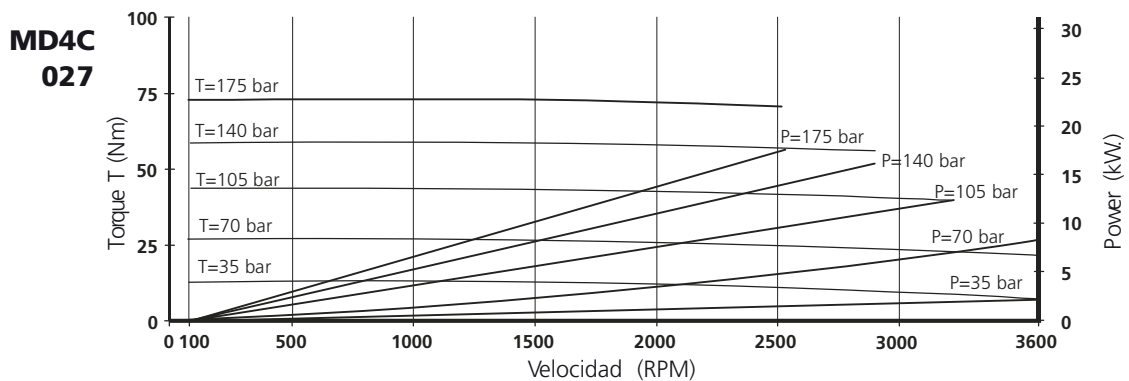
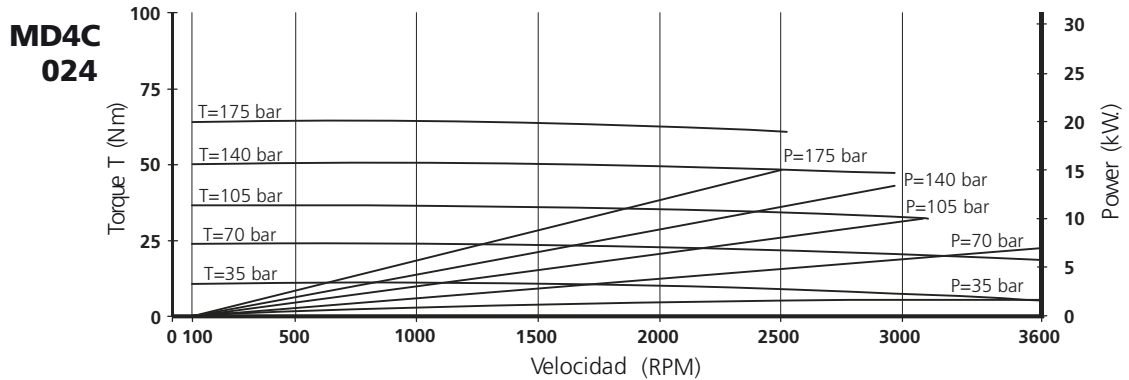



PERFORMANCE CURVES - OIL VISCOSITY : 24 CST (45°) - MD4C

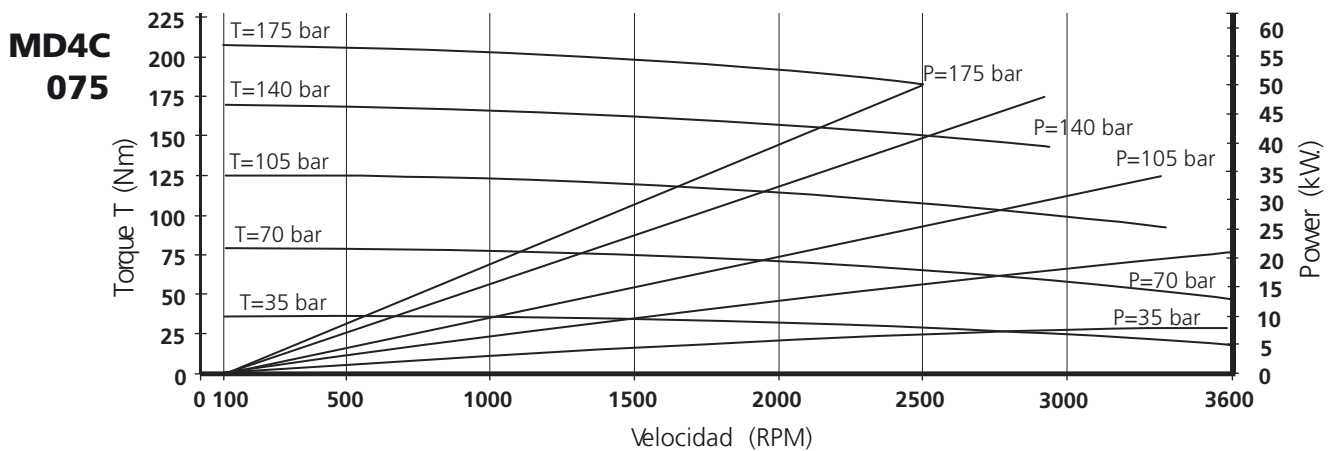
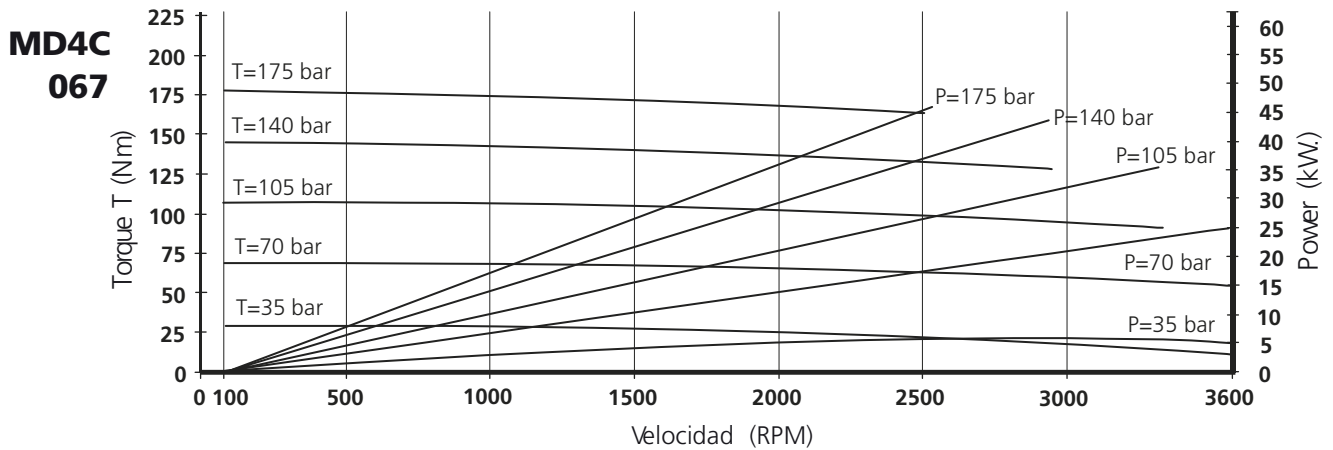
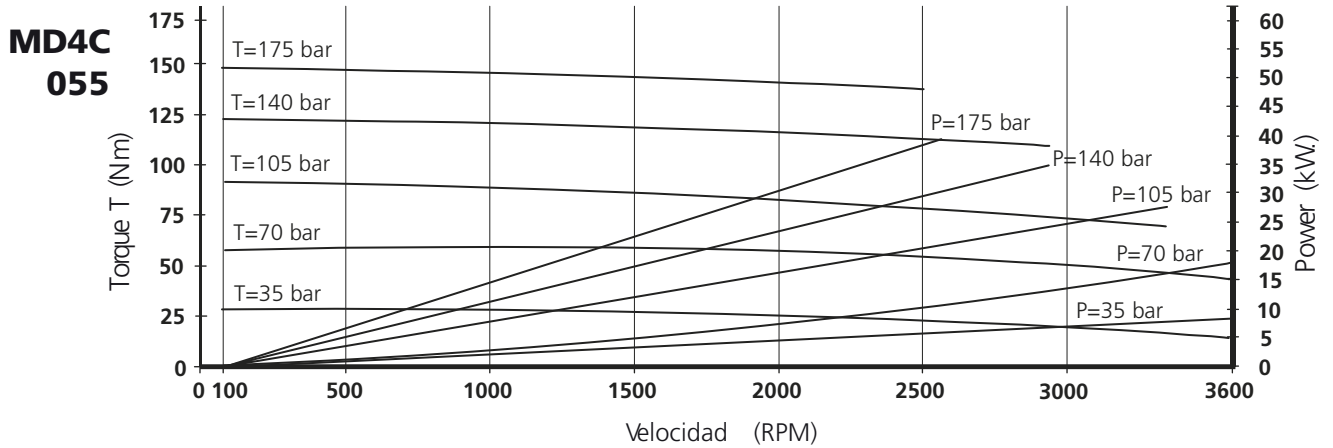

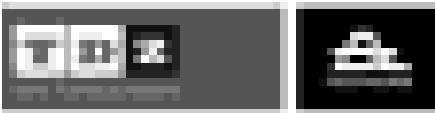

MH4D - ORDERING CODE & OPERATING CHARACTERISTICS

DATA SHEET

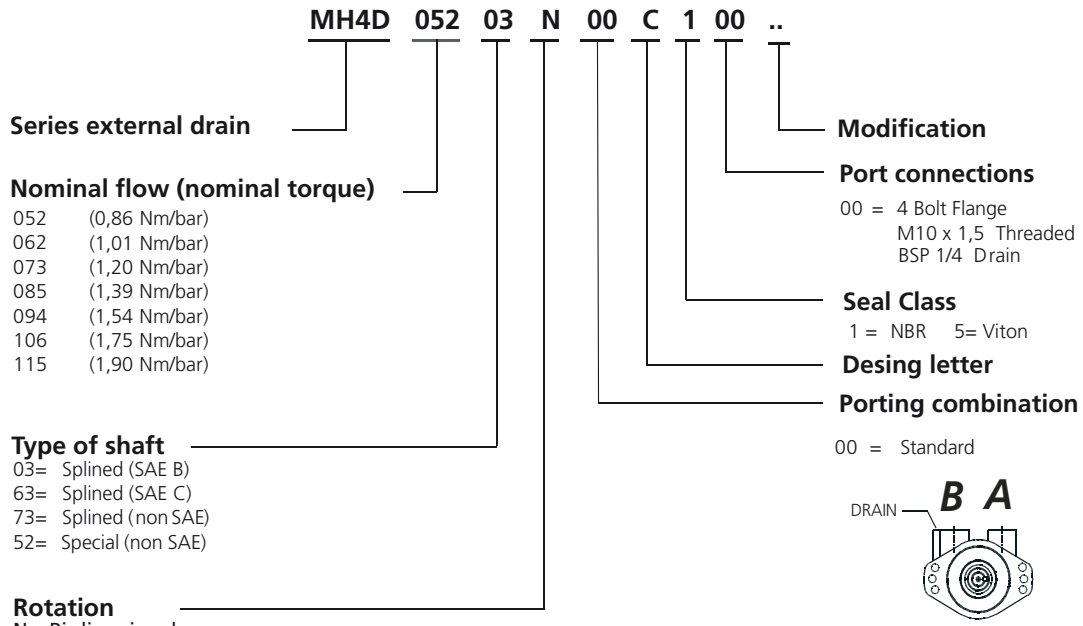

View from shaft end:

- CW Rotation:** A= INLET
B= OUTLET
- CCW Rotation:** A= OUTLET
B= INLET

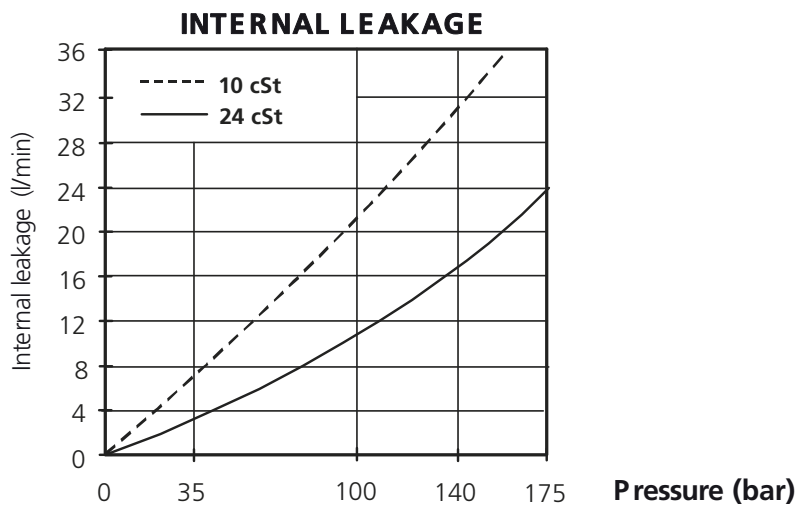



DIMENSIONS, SHAFTS & PORT CONNECTIONS - MH4D

DIMENSIONS IN MILLIMETERS. 1" = 25,4 mm

PORT CONNECTIONS

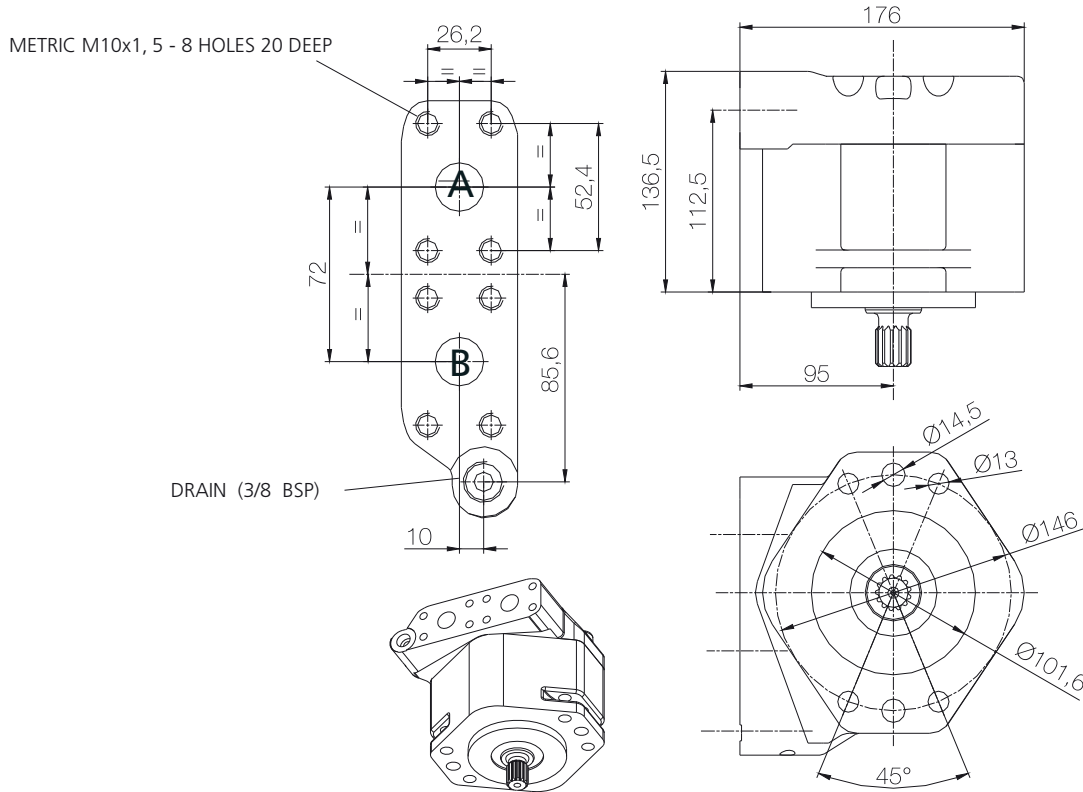

SHAFT TYPE

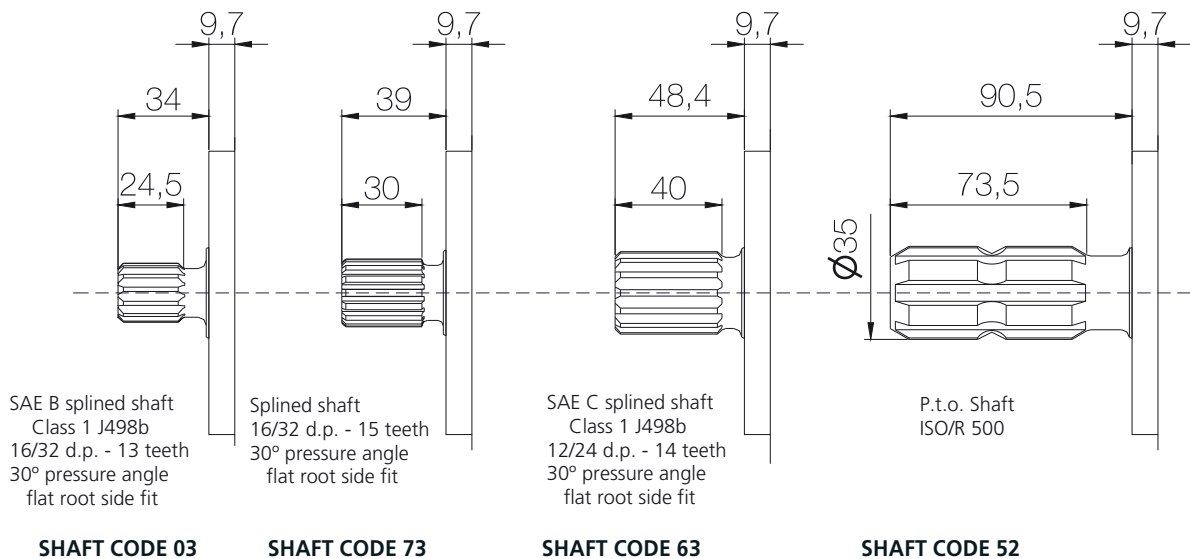

Enquire about other types of shafts

DATA SHEET



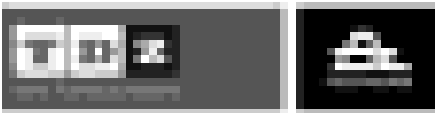

PERFORMANCE CURVES - OIL VISCOSITY : 24 CST (45°) - MH4D

DATA SHEET

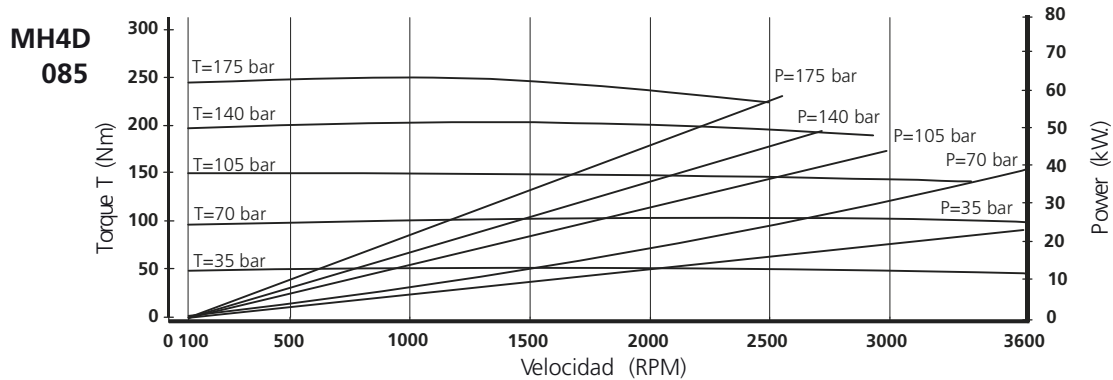
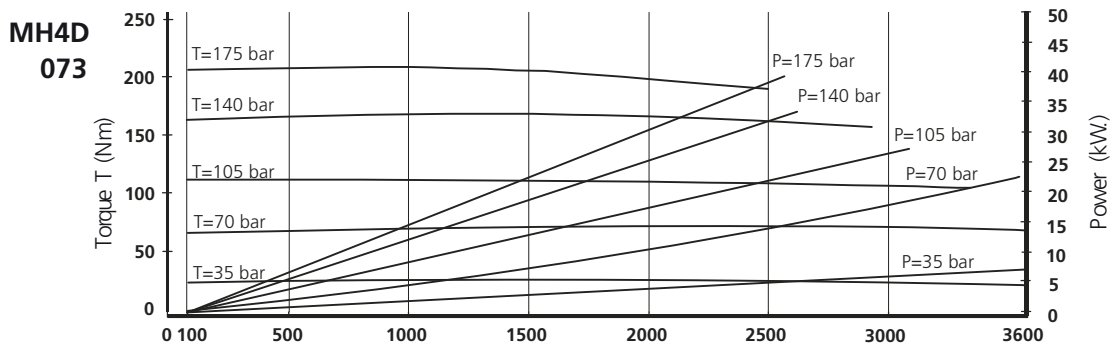
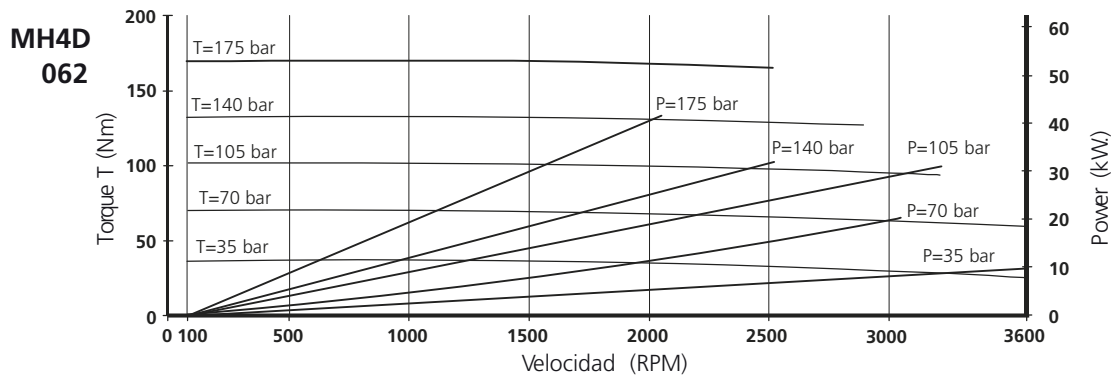
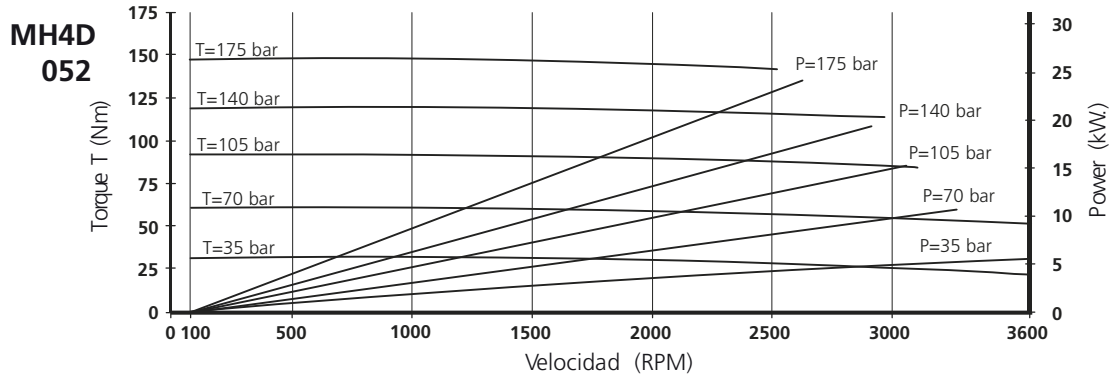

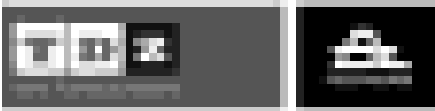

PERFORMANCE CURVES - OIL VISCOSITY : 24 CST (45°) - MH4D

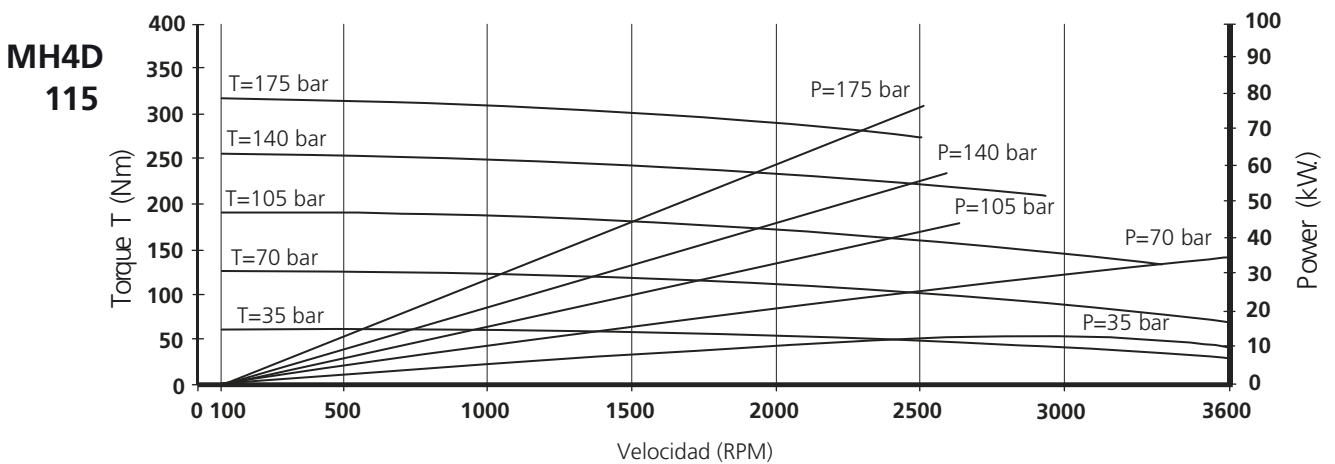
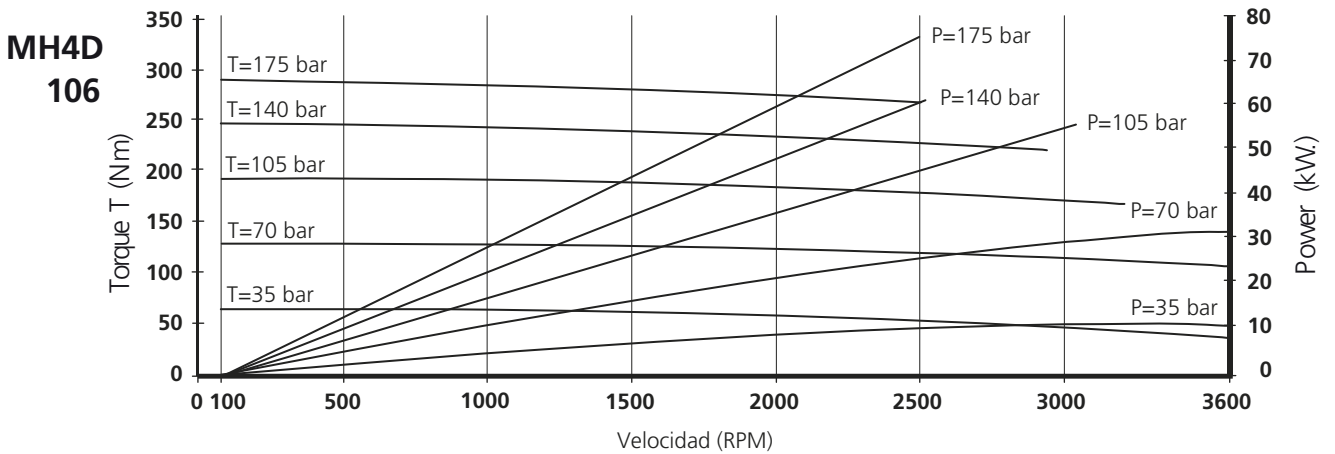
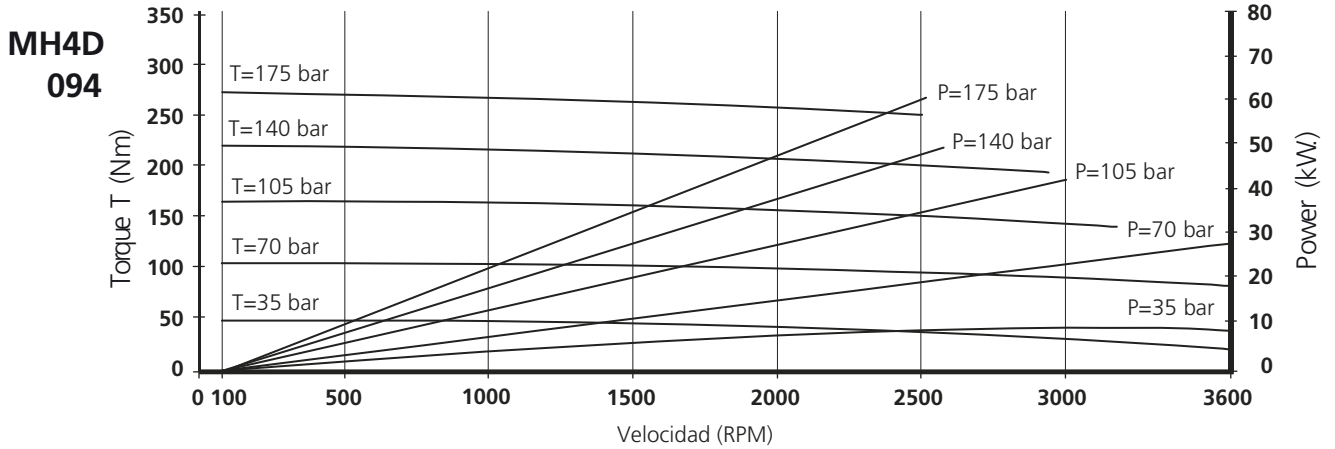



VANE PUMP DESCRIPTION FACTORS AFFECTING PUMP LIFE

USE, MAINTENANCE AND REPAIR GUIDE



PUMP CONSTRUCTION AND PARTS IDENTIFICATION

PUMP PARTS

The components of a typical vane-type pump are shown in Figure 1. This single-section pump has one cartridge assembly.

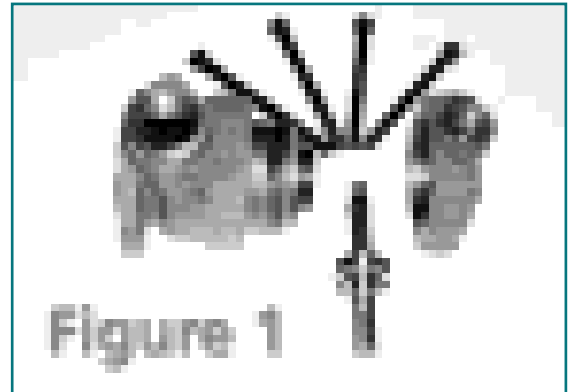

Double-section pumps (Figure 2) are similar, but have a longer shaft and housing, and use two cartridge assemblies. The housing sections include the body and covers, which have the openings for line connections. Also shown are the shaft with drive end bearing and seal, and the O-ring seals necessary to isolate the inlet and outlet compartments when the cartridge is assembled in the housing sections.



CARTRIDGE PARTS

Figure 3 shows the individual parts of a cartridge assembly. These high-precision parts comprise the actual pumping unit. The vanes (and vane inserts in most pumps) fit in the slots of the rotor, which is splined to, and driven by, the pump shaft. The rotor is installed on the shaft in the centre of the oval shaped cavity inside the cam ring. The cam ring is a liner for the housing, hardened for high resistance to wear. It is machined to provide the correct side clearance for the rotor and vanes, and the correct internal contour for the vanes to follow. The end plates fit against both sides of the cam ring, enclosing the rotor and vanes. Two pins hold all the parts in alignment, and two screws retain the assembly. Both plates have grooves and passages to control oil flow. The larger of the two end plates has the outlet ports and is usually called the pressure plate. The other plate, used on the inlet side is called the wear plate. Oil pressure behind the pressure plate holds the pump components together.



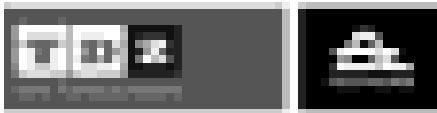

PRINCIPLE OF OPERATION AND OIL FLOW

During operation, the vanes are held outward against the cam ring by internal hydraulic pressure. Pressure oil enters the cavity between the vane and vane insert through the groove in one side of the rotor slot, causing the insert to act as a small piston. With the insert against the bottom of the rotor slot, the pressure oil between the top of the insert and the vane gives a uniform, controlled force to hold the vane outward. Any oil in the slot under the vane on each side of the insert can flow out through the drilled holes to the outside diameter of the rotor.

As the shaft turns the rotor, the vanes follow the internal contour of the cam ring. There are two points of minimum clearance between the rotor and cam ring, and two points of maximum clearance. These four points are located alternately each 90° of rotation. As the rotor turns, the vanes move outward during 90° of rotation, then inward during the next 90° of rotation. This completes a pumping cycle each 180° or one-half turn, giving two complete pumping cycles per revolution. With this design, the pressure loads and rotation resistance are equal on both sides of the rotor, so the internal forces are in balance. This keeps bearing loads and other stresses low for longer pump service life.

PUMPING ACTION

Each pair of vanes forms a pumping chamber which increases in volume as the vanes move outward, and decreases in volume as the vanes move inward. This change in volume, or displacement, produces the pumping action. During the rotation quadrant (90°) where the volume increases, oil is drawn into the chamber through the inlet port. As the chamber moves through the next quadrant, the volume decreases and the oil is forced out through the outlet port. Pressure develops only in direct relation to any restriction downstream from the pump outlet. If there is no restriction, the oil flows without pressure.

For the two pumping cycles per revolution, two inlet and two outlet ports are used. These are located alternately in each quadrant to permit oil flow in and out of the pumping chambers. Since the chambers are closed, and displace a specific volume per revolution, the pump is a positive displacement type.

PUMP ROTATION

When installing a replacement pump or pump cartridge, be sure to check the direction of rotation. The cartridge assembly is directional in rotation, but most cartridges can be reversed if necessary. Changing the direction of rotation changes the part number of the cartridge. To do this, it is only necessary to exchange the end plates. The cam ring, rotor, and vanes are the directional parts, and these must be correctly aligned with each other. Vane direction can be identified by the bevelled outer edge: The side in contact with the cam ring is the front, or leading side; the bevel is toward the back of the vane. The cam ring and rotor are marked with arrows showing the direction of rotation, and these arrows must be aligned to point in the same direction. A number is stamped beside the arrow on the cam ring. This number is a standard gallons-per-minute rating of the manufacturer under consistent, specific conditions, and can be used for comparative purposes; i.e., the cam ring of a new cartridge should have the same number as the cam ring of the cartridge that was removed. Normally, the manufacturer's rating is established at 1200 RPM and 100 PSI (7.03 kg/cm²), with oil at 150°F (66°C).





FACTORS AFFECTING PUMP LIFE

Today, TDZ machines use hydraulics almost exclusively to power implement and steering systems. Increased machine productivity has resulted in the design and use of greater capacity pumps and higher pressure systems. The new pumps and higher pressures impose greater stress on system components.

The vane-type hydraulic pump will normally provide good service when it is operated with a good grade of oil in a system that is clean and functioning properly. However, improper maintenance of the hydraulic system can cause early pump failure. Determining and correcting the cause of pump failure will insure adequate service life for the replacement pump.

This information is to assist in making a correct analysis of wear patterns or damage to pump parts. A correct analysis is very important in finding the basic cause of failure so it can be corrected. Unless the basic cause is corrected, a repeat failure is inevitable. Any time a pump or cartridge must be replaced, especially after early failure, inspect all the parts very carefully. The damage may not be as well defined as the examples shown, and/or the parts may have more than one type of damage. Also, the most obvious damage may not be the basic cause of failure. For example, a rotor seizure can be the result of gradual deterioration due to abrasive dirt or metal particles in the oil. If so, the contamination is the basic cause of failure, not the rotor seizure. This can be determined only by a careful, thoughtful study of the pump parts. A correct analysis and identification of the basic cause of failure is essential to prevent repeat failures.

The TDZ vane pump is the heart of the hydraulic system, which is a major component of the machine. When making an analysis of a pump failure, it is essential to consider all the factors affecting machine operation, including machine equipment, operator proficiency, job conditions and machine application. Be sure to check each of the following items:

1. Condition of each part of the pump and cartridge.
2. Type, grade and condition of hydraulic oil and filters.
3. Operating conditions and symptoms before and at the time of failure.
4. Condition of other components of the hydraulic system.
5. Severity of conditions in the job application.
6. Length of pump service life before failure.
7. Previous failures and repairs to the hydraulic system.

The factors affecting operation of the pump and hydraulic system are closely related and must be considered in conjunction with each other. Recognition of the various conditions and possibilities will aid in understanding the relation of pump damage characteristics to the hydraulic system.

HYDRAULIC OIL

The oil used in the system must have the correct additives and film strength sufficient to maintain a lubricating film, especially between the vanes and cam ring. Always use a high quality oil of the correct type and grade containing additives to control oxidation, foam, rust and wear. The anti-wear additive is very important and the present recommendation is to use oil containing zinc dithiophosphate or a comparable additive.

HIGH OIL TEMPERATURE

Excessive heat in the hydraulic system is a primary cause of seal failure. Oil temperatures in the tank must not exceed 200° - 210°F (93° -99°C), or damage can result. To keep the oil below critical temperatures, the hydraulic system must be well maintained, in efficient operating condition, and must not be abused or overloaded. Where there is evidence of high oil temperature, inspect the oil cooler to be sure it is clean and



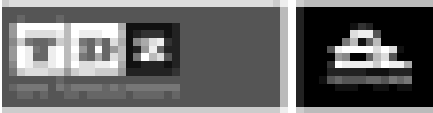

FACTORS AFFECTING PUMP LIFE

functioning correctly, then check the system for bypassing of oil at high pressure. Any bypass of high pressure oil causes a rapid rise in oil temperature. Some possible causes of bypassing are:

- ... A worn pump, permitting oil to bypass internally from the high pressure to the low pressure side of the pump.
- ... A worn or sticking control valve or relief valve.
- ... A low pressure setting of the relief valve, allowing it to open too frequently.
- ... Frequent relief valve operation caused by excessive pressure in the system.
- ... Loose, missing or damaged parts, such as a seal or gasket, in the tank.

OIL SEALS

Hydraulic system seals are very important, and must be inspected frequently and carefully. The most critical seals are those on the hydraulic cylinder rods. The cylinder rods are the only hydraulic system components which are exposed alternately to both external and internal conditions, and only the seals prevent dirt from being carried directly into the system. If the lip of the wiper seal has no visible damage, there is no oil leakage, and the rod has no visible damage, these parts can be considered in good condition. Any worn or damaged seals, especially the wiper seal, can permit dirt to enter the system.

Seal damage is frequently caused by hot oil. Depending upon its material content, the seal may become hard and brittle, causing cracks; soft and pliable, permitting extrusion; or it may erode away. Seal effectiveness also depends on the contact surface of the cylinder rod, which the seal must wipe clean with every stroke of the cylinder. If the rod surface is scored, peened, pitted, rusted or worn, the seal cannot function effectively. In conditions where the cylinder rods can be damaged by falling rocks or other material, guards should be installed to provide protection.

SYSTEM OVERLOADING

The hydraulic system can be overloaded either by overloading the machine, or by poor operating practices. The machine is designed for optimum performance under specific conditions of weight, loads and operation. Oversize buckets, blades or other implements, and/or ballast or counterweights heavier than recommended, cause overloading of the machine and hydraulic system. Working the machine against extreme loads and/or bottoming the hydraulic cylinders causes excessive pressures. These pressures are potentially damaging, and should be prevented whenever possible. With a machine in good operating condition, correctly equipped and matched to the job, the operator should be able to achieve optimum production without exceeding the maximum pressure setting of the relief valve in the system more than once per machine cycle.

PUMP LUBRICATION

The pump must have an adequate supply of oil at all times. Before installing a new pump or a pump having a new cartridge, fill it with the same oil recommended for the system, and turn the shaft to distribute the oil over all the internal surfaces. This procedure is very important to prevent damage or excessive wear to the pump during the priming period after the engine is started. Also, to maintain pump lubrication, correct procedures must be followed when filling a system that has been drained. Remember, you are filling the system, not just the oil supply tank. Pump failure due to lack of oil can result if filling is not done correctly. The tank contains only enough oil to take care of changes in volume when the hydraulic cylinder rods are extended or retracted during machine operation. Refilling the hydraulic cylinders, lines and accumulators after the system has been completely drained may require a volume of oil two or three times the capacity of the tank. Therefore, oil must be added to the tank several times to be sure the system has an adequate supply. If the oil level in the tank drops too low, the new pump can be severely damaged by a lack of oil or by aeration of the oil. If the return oil in the tank discharges above the oil level in the tank, aerated oil will result. During operation, pump damage due to poor lubrication can result from excessively high oil temperature, using the wrong type of oil, or a lack of adequate oil supply.





PUMP SHAFT LUBRICATION

Lubrication of the drive splines on the pump shaft is completely separate from the hydraulic system. These splines receive lubrication from the engine oil system or other drive compartment through the pump drive. Spline wear can be due either to a defective shaft, which is not hardened correctly, or to a lack of shaft lubrication. Where splines are worn, make a careful inspection of the pump drive. Check all oil passages, including openings in seals, gaskets and sleeve-type bearings. An oil passage can be closed by an incorrectly installed seal, a gasket installed with the oil hole in the wrong position, or a wrong gasket having no oil hole. Also, a sleeve-type bearing with no oil hole, or installed with the oil hole in the wrong position, can prevent oil flow.

AERATION AND CAVITATION

Aeration and cavitation are two completely different conditions, but have very similar damage characteristics. Aeration is a mixing of air with the oil, either by excessive agitation or air leakage into the system; cavitation is the result of a restricted oil supply to the pump. In either condition, small bubbles of air or oil vapour are mixed with the flow of oil. These bubbles displace some of the oil, causing poor lubrication, and they are compressible, causing unstable vane action. Where a quantity of air bubbles enters the lines and cylinder, the compressibility can cause spongy or jerky operation and loss of a positive feel. Since the bubbles are compressible and the oil is not, the sudden collapse of the bubbles under pressure in the pump causes a hammering or pounding as the oil closes the spaces. This results in a vibration which can be strong enough to crack or break the cam ring, pump body and/or body bolts. This is also the source of the characteristic sound, often described as "pumping marbles". The forces produced by the collapsing bubbles cause erosion and pitting of pump parts.

Aeration can be caused by:

- ... A low oil level. This can cause agitation if the return line is exposed, or let air directly into the pump suction line if the inlet line is exposed.
- ... An air leak in the pump suction line.
- ... Air leakage at a cylinder rod seal or line connection. When the implement is lowered, especially with the control valve in the float position, there is a vacuum in the rod end of the cylinder, and damaged rod seals or rods will permit air entry in the system.
- ... Tank agitation caused by damaged parts, such as: loose or broken hose, loose or missing baffles, or a return tube bent in a wrong direction.
- ... Agitation caused by excessive flow through the relief valve. This can be due to a low pressure valve setting, or excessive system pressure caused by machine overloading or poor operating practices.
- ... Water contaminated hydraulic oil. Although not aeration, it will have the same effect on pumps.

Cavitation can be caused by:

- ... Any restriction limiting the flow of oil through the pump inlet line. If the line is too small, a tube is bent, a hose collapsed, or the suction screen clogged; the flow of oil to the pump will be limited.
- ... A high vacuum in the tank, which retards the flow of oil.
- ... Hydraulic oil too viscous or thick to flow easily through the lines, especially in cold temperatures.

Since aeration and cavitation cause similar damage to the pump, further tests may be necessary to determine which condition is the cause of failure. Where damage characteristics indicate aeration or cavitation, first look for obvious problems, such as: A bent suction tube, collapsed suction hose, or thick, heavy oil which could cause cavitation; or a cracked suction tube, loose suction hose, or low oil level which could cause aeration. If none of these are evident, and the machine is in service, a "bottle test" can be made as follows:





FACTORS AFFECTING PUMP LIFE

1. Oil in hydraulic tank should be at normal operating level. Run engine at high idle for five minutes with all control valves in "HOLD" position. Be sure the oil is at, or near, the temperature of 150°F (66°C).
2. Lower a small, clean, clear glass bottle into the oil through the tank filler tube, and remove a sample of oil.
3. Hold the bottle up to a strong light and look through the oil for foam and/or bubbles, indicating aeration.
4. If oil is aerated, cause is either a suction line leak or oil discharge in the tank above the oil level. Make necessary corrections so that test can be repeated and a clear oil sample obtained.

If the problem is cavitation and occurs only at the time of starting, and oil viscosity is correct, a high vacuum may exist in the tank. This can be corrected by loosening the filler cap before starting the machine.

OIL SAFEGUARDS

There are several maintenance procedures that are particularly helpful in assuring satisfactory pump and hydraulic motor life.

Two of the most important are:

- Oil sampling
- System flushing.

OIL SAMPLING

A Scheduled Oil Sampling (SOS) program can provide an early warning of some hydraulic system problems. Normally, the testing will not detect particles larger than 10 microns in size, but will detect material such as fine abrasive dirt (silicon) or metal (iron) which is not visible in the oil. Since these fine particles are not visible, the oil can look clean. In addition to causing pump wear or damage, the presence of these particles may indicate other problems in the system. When the test reading shows a high iron content, it may indicate excessive wear or dam which could result in a failure. The test reading of silicon, which shows the amount of dirt in the oil, is normally less than 10 PPM (Parts per Million). When this reading shows a sudden increase, or is as high as 35 PPM, excessive dirt is entering the system. Since cylinder rods and seals are the most common point of dirt entry, make a careful inspection of these parts (See the topic "Oil Seals"), then perform a "Tee Test" to check pump condition.

FLUSHING THE SYSTEM

Abrasive dirt, metal particles or any other contaminants must always be removed from the hydraulic system. Contamination is a frequent cause of pump failure, often due to incorrect flushing procedures after a previous failure. Correct flushing procedures are given in Special Instructions Forms FE040041-01 and GMG00234 for loaders and Form FM055145 for tractor-scrappers. These procedures can be adapted to the hydraulic systems on most other Caterpillar machines, since the basic principles of flushing are similar. Always be sure to flush the system thoroughly after any failure which can introduce metal particles, dirt or any other contaminants into the oil.

If desired, the drained oil can be filtered and reused. This will reduce the quantity of oil needed by as much as 50%. The filter must remove particles 10 microns or larger in size. With diminishing supplies, and the increasing cost of oil, filtering is a practical method of conservation and cost reduction.



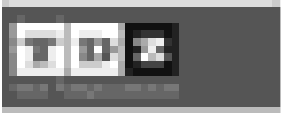

TROUBLESHOOTING TABLE

TROUBLESHOOTING GUIDE
GLOSARY OF TERMS

USE, MAINTENANCE AND REPAIR GUIDE





NO FLOW, NO PRESSURE

A) Is the pump rotating?

- a-1) Check if the coupling is rotating. If not, check the rotation of the electric motor.
- a-2) Check the keys of the pump and E motor shaft.
- a-3) Check if the shaft is not broken.

B) Is the rotation in the correct direction?

- b-1) Check if the rotation of the pump corresponds to the arrow on the name plate.
- b-2) Check if the wiring of the electric motor is correct.

C) Is the air bleed-off done?

- c-1) Check that no air is still located in the pressure line. Loosen a connector

D) How are the inlet conditions?

- d-1) Check if the inlet gate valve is not closed.
- d-2) Check the oil level.
- d-3) Checks if the inlet hose in the tank is under the oil tank level.
- d-4) Checks if an air intake is not disturbing the inlet (missing inlet flange seal, air trapped in suction line as examples).
- d-5) Check if the pump is not located too high above the oil level.
- d-6) Check if the tank is not completely sealed. Then the lack of atmospheric pressure will not allow the pump to prime.
- d-7) Check if all connections and seals are air-tight.

E) Is the Viscosity not too high?

- e-1) Check if the oil characteristics are not incompatible with the temperature and the pumps requirements. Too high Viscosity will "stick" the vein fluid and enable the pump to suck the oil correctly.

F) Is the pump flow not going somewhere else?

- f-1) Check the hydraulic circuit and the main sequences. Doing so, you will check if all the valves are set or work properly.
- f-2) Check if the main relief valve is not set at an extremely low pressure and therefore bringing all the flow back to the tank.
- f-3) Checks if in the directional valves the spools are not sticking in a position that brings the flow back to the tank.
- f-4) checks if the check valve is not mounted "upside down".

G) Is the receptor working correctly?

- g-1) Check if the motor does not let the entire flow leak internally.
- g-2) Check if the cylinder inner seals are not ruined.

H) Is the speed high enough?

- h-1) Check if the minimum speed is reached. Mobile pumps require 400 rpm and industrial pumps require 600 rpm.



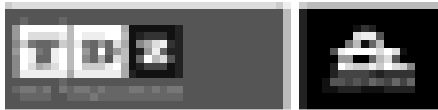

NOT ENOUGH FLOW (OR NOT THE FLOW REQUIRED)

A) Are the components OK?

- a-1) Check the displacement of the pump.
- a-2) Check if the speed of the pump is not too low or too high (E motor or thermal engine sized too small so dropping the speed too low...).
- a-3) Check if the main relief valve is not set at an extremely low pressure and, therefore, venting some flow back to the tank.
- a-4) Check if in the directional valves the spools are not sticking in a position that brings part of the flow back to the tank.
- a-5) Check if the hydraulic motor is not leaking internally due to a bad efficiency, low viscosity...
- a-6) Check if the cylinder inner seals are not ruined and, therefore, allow internal leakage.

B) Is the connection from the tank to the pump correct?

- b-1) Check if there is no air intake between the pump and the inlet pipe (bad seals for example).
- b-2) Check if the inlet hose is convenient for the required velocity ($0,5 < V < 1,9$ m/s).
- b-3) Checks if the pump is not too high compared to the oil level or if the pump is not too far from the tank (checks the inlet absolute pressure with the catalogue values).
- b-4) Check if the gate valve is not semi-open.
- b-5) Checks if the inlet strainer is sized correctly (250 m mesh mini) or not clogged.

C) Is the tank design correct?

- c-1) Check if the oil level is correct.
- c-2) Check if the suction pipe is under the oil level during the complete cycle of the machine.
- c-3) Checks if the inlet hose fitted in the tank is cut with an angle wider than 45° .
- c-4) Check if this inlet hose is not too close to the tank wall or to the bottom of the tank and therefore limits the "vein flow".
- c-5) Check if the suction hose is not located near the return line and therefore sucking a lot of air coming from these turbulences.
- c-6) Check if baffles are required to allow correct deaeration of the fluid.
- c-7) Check if the air filter is not clogged or under seized (not well dimensioned).
- c-8) Check if the tank is not fully tight, not allowing the atmospheric pressure to apply.

D) Is the oil convenient?

- d-1) Check if the oil characteristics are not incompatible with the pumps requirements.
- d-2) Check if the viscosity is not too high, therefore "sticking" some vanes in the rotor or blocking the vein fluid.
- d-3) Check if the high temperature does not destroy the viscosity of the fluid. Doing so, the internal leakage will "consume" the flow.

NO PRESSURE

A) Is the hydraulic circuit correctly designed?

- a-1) Check the hydraulic circuit schematic.

B) Is the circuit correctly piped?

- b-1) Compare the schematic to the piped circuit.

C) Are the components working correctly?

- c-1) Check the main sequences. Doing so, you will check if all the valves are set or work properly.
- c-2) Check if the main relief valve is not set at an extremely low pressure and therefore bringing all the flow back to the tank.
- c-3) Check if in the directional valves the spools are not sticking in a position that brings the flow back to the tank.





NOT ENOUGH PRESSURE

A) Check as when “no pressure”

B) Is the system well dimensioned?

b-1) Check if the flow required is not over the available flow and therefore cannot build-up pressure.

C) Is there an internal leakage somewhere that maintains a certain pressure?

c-1) Check all the possible faulty components, from the pump to all the receptors and intermediates (high pressure seals, mechanical wear...).

UNCOMMON NOISE LEVEL

A) Is the noise coming from the pump?

a-1) Check the mechanical link of the shaft pump : alignment, balancing of the coupling or Universal joint, key properly fastened, ...

a-2) Check if the air bleed has been done correctly.

a-3) Check if there is no air intake from the tank to the pump (not through the shaft seal).

a-5) Check if the hose strain force does not create this noise.

a-6) Check if the oil level is correct.

a-7) Check if the oil in the tank is not aerated.

a-8) Check if the strainer is not clogged or under dimensioned.

a-9) Check if the inlet pipe is under the oil level.

a-10) Check if the air filter is not clogged or too small.

a-11) Check if the speed is not incompatible with the catalogue values.

a-12) Check if the oil is compatible with the catalogue recommendations.

a-13) Check if the inlet pressure is not higher than the outlet pressure.

B) Is the noise coming from the surroundings?

b-1) Check the hoses and see if the noise is not coming back to the pump this way.

b-2) Check the pressure piping and see if its length dumps or amplifies the noise.

b-3) Check if the structure of the tank is stiff enough to avoid amplification/resonance.

b-4) Check the E motor fan.

b-5) Check the balancing of the E motor.

b-6) Check the water cooler and its theoretical limits.

b-7) Check the filtration unit, its capacity and if the noise does not come from the opened by-pass valve.



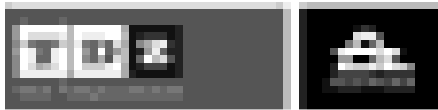

UNUSUAL HEAT LEVEL

A) Does the heat appear when the pump is running without pressure?

- a-1) Check the oil level and the suction pipe. Is the oil coming to the pump (check the length of the pipe, its internal diameter, all that could influence the inlet pressure)?
- a-2) Check if the air bleed has been done correctly. a-3) Check if the flow versus the volume of oil in the tank is correct to obtain a good cooling effect.
- a-4) Check if a cooler is required or, if there is one, if it is well dimensioned.
- a-5) If there is a cooler, check if it is working (example for water cooler: is the water flow open or sufficient).
- a-6) Check if the hydraulic circuit is not bringing back the flow directly to the inlet port. Doing so, it would create a very small closed circuit not able to cool down the fluid.
- a-7) Check the quality of the fluid.
- a-8) Check the velocity of the fluid.
- a-9) Check the filtration unit, its capacity and if the heat does not come from the open by-pass valve or if it is under-dimensioned (bigger delta P).

B) Does the heat appear when the pump is running with pressure?

- b-1) Check the viscosity.
- b-2) Check the pressure rating.
- b-3) Check if the cooler is working correctly or well dimensioned.
- b-4) Check if the relief valve is not creating this heat because always opens.
- b-5) Check if any other component in the system is not creating this heat due to an internal defect.
- b-6) Check if there is a big temperature differential between the inlet and the outlet.

SHAFT SEAL LEAKAGE

A) Is the seal destroyed?

- a-1) Check the alignment and the correct power transmission (non homokinetic movement, high radial force as examples).
- a-2) Check the inlet pressure and compare it to the catalogue values.
- a-3) Check if the bad suction conditions do not create a vacuum that could even reverse the seal lip.
- a-4) Check if the external environment is not too dirty and therefore ruining the seal.

B) Is the seal only leaking?

- b-1) Check the alignment of the front shaft and check if there is not any radial load.
- b-2) Check if seal lip has not been cut during a maintenance operation.
- b-3) Check if the inlet pressure is not over or under the catalogue values. This has to be done for the whole cycle because the inlet pressure can vary from time to time. b-4) Check if the seal material has not been modified due to a too warm environment. The seal can vulcanize and stop sealing correctly.
- b-5) Check the acidity of the oil that can "bum" the seals material. It will therefore destroy the elasticity of the sealing.
- b-6) Check if the chosen seal (high pressure seal for example) is not too stiff for the use. If the environment requires some elasticity due to a gentle misalignment, a high pressure seal will not be able to follow the movement and therefore leak.





NO ROTATION

A) Is the flow coming to the motor?

- a-1) Check the circuit and the hydraulic schematic. Is the piping OK?
- a-2) Check the setting of the main pressure relief valve. Check if it not settled at an extremely low pressure.
- a-3) Check if the pump is giving a flow.
- a-4) Check if the directional valve(s) allowing the flow to go to the motor is energized. If it is, check if the spool is in its correct position and not sticking in a position that would deviate the flow somewhere else.
- a-5) Check if a check valve would not have been improperly mounted.

B) Is the torque required higher than the system settings?

- b-1) Check if the pressure settings are correct.
- b-2) Check if the load is not superior to the torque capabilities of the motor.

C) Is the pump OK?

- c-1) Check if the pump is working correctly.

D) Are the motors internal drain check valves working properly?

- d-1) Check if a failing check valve would not allow some flow to go back to the tank and therefore limit the flow to the motor.

E) How is the motor piped?

- e-1) Check the nature of the connectors. If, for example, the "self sealing couplings" type connectors are well fitted into each other.

STALLS EASILY

A) Is the load near the limits of the system?

- a-1) Check the relief valve setting and compare it to the theoretical pressure required to deliver the convenient torque.

B) Are the motors internal drain check valves working properly?

- b-1) Check if a failing check valve would not allow some flow to go back to the tank and therefore limit the flow to the motor.

C) Is the flow going to the motor sufficient?

- c-1) Check the minimum flow required by the motor.
- c-2) Check the flow of the pump or the valve feeding the motor.

NOT ENOUGH SPEED

A) Is the speed lower than desired?

- a-1) Check the theoretical displacement of the motor versus the theoretical flow of the pump.
- a-2) Check that the flow of the pump is really coming to the motor.
- a-3) Check that the working pressure & speed are not incompatible with the catalogue values of the motor.
- a-4) Check the oil temperature. Check then that the low viscosity of the oil is not having a big effect on the internal leakage of the motor.
- a-5) Check the air bleed-off.



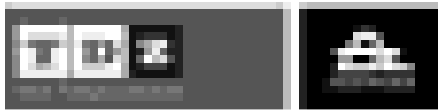

ERRATIC SPEED

A) Is the motor loosing speed erratically?

- a-1) Check if the limit of the allowable torque is not reached once a while.
- a-2) Check if the driven load does not transmit some inconstant load (high pressure piston water pumps with an unbalanced technology).
- a-3) Check if the flow coming from the pump is constant.

UNUSUAL NOISE LEVEL

A) Is the motor running?

- a-1) Check if there is no air intake aerating the motor badly (through the front shaft seal for example).
- a-2) Check if the motor is not cavitating. It could be that the inertia of the load is such that it drives the motor faster than the flow coming from the pump.
- a-3) Check if the oil is not proper for the use.
- a-4) Check if the air bleed has been done properly.

B) When the motor is breaking?

- b-1) Check the back pressure to see if the replenishment pressure is not too low, leading to cavitation of the motor.

UNUSUAL HEAT

A) Is the oil arriving to the motor already hot?

- a-1) Check if a cooler is required or if there is one if it is well dimensioned.
- a-2) If there is a cooler, check if it is working (example for water cooler: is the water flow opened or sufficient).
- a-3) Check if the hydraulic circuit is not bringing back the flow directly to the inlet port. Doing so, it would create a very small closed circuit not able to cool down the fluid.
- a-4) Check the quality of the fluid.
- a-5) Check the velocity of the fluid (5 to 6 meters/second max.).
- a-6) Check the filtration unit, its capacity.
- a-7) Check if the heat does not come from an open bypass valve.

B) Is the oil heating up when going through the motor?

- b-1) Check the speed of rotation versus the catalogue values.
- b-2) Check the pressure rating.
- b-3) Check the fluid.
- b-4) Check the viscosity.



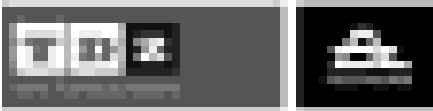

TROUBLE-SHOOTING GUIDE

| IDENTIFICATION | CAUSE | CHECK LIST |
|--|---|--|
| <ol style="list-style-type: none"> 1. Gray (sandblasted) appearance of wearing surfaces, especially vane faces. 2. Worn rotor slots. 3. Blunt vane edges 4. Chopped/rippled cam ring, possible wear steps. | <p>Abrasive wear-fine particles of dirt, not visible in the oil.</p> | <ol style="list-style-type: none"> 1. Inspect cylinder seals and rods. If seals are deteriorated, look for other evidence of high oil temperature and check for cause. If cylinder rods are damaged, check for cause of damage. 2. Check for clean oil supply. 3. Correct filter elements, change intervals and proper installation? 4. Was system flushed after previous failure? |
| <ol style="list-style-type: none"> 1. Metal smearing on vane faces. 2. Schratching and scoring of wear plate and rotor. 3. Store marks on vane edges and cam ring. 4. Vanes jammed in rotor slots. 5. Larger particles cause scoring of rotor and cam ring. 6. Rotor jammed by metal object. | <p>Damage from metal particles or objects-50 microns or larger visible in the oil.</p> | <ol style="list-style-type: none"> 1. Was system properly flushed after previous failure? 2. Is another component in process of failure. 3. Are particles due to excessive pump wear? 4. Were metal pieces left in system after previous work? |
| <ol style="list-style-type: none"> 1. Rippling and pitting of cam ring. 2. Erosion of end plates. 3. Severe vane wear. 4. Cracked or broken puma body, body bolts and/or cam ring. | <p>Aeration-Air mixed with the oil, causing bubbles and lack of lubrication. Water-contaminated oil.</p> | <ol style="list-style-type: none"> 1. Low oil level. 2. Air leakage at pump suction line. 3. Air leakage at cylinder rod, seals, or cylinder line connections. 4. Bent, damaged or missing parts in tank, causing agitation. 5. Low pressure setting of relief valve, causing excessive bypassing. 6. Excessive operation of relief valve due to overloading poor operating practice, or other conditions. |
| | <p>Cavitation: Restriction or limitation of oil supply to pump.</p> | <ol style="list-style-type: none"> 1. Oil viscosity. 2. Collapsed hose in pump suction line. 3. Clogged screen or other restriction of pump inlet. |
| <ol style="list-style-type: none"> 1. Dark, discolored parts. 2. Excessive wear of vanes and cam ring. | <p>Poor Lubrication</p> <ul style="list-style-type: none"> -Wrong type of oil or high temperature. -Restricted engine or transmission oil supply to pump drive. | <ol style="list-style-type: none"> 1. Check seals for evidence of high oil temperature. If found, check for cause, and inspect all seals for damage specially piston rod seals. 2. Quality, type and grade oil. |
| <ol style="list-style-type: none"> 1. Worn splines on pump drive shaft. | | <ol style="list-style-type: none"> 1. Check. for closed oil passages in pump drive. |
| <ol style="list-style-type: none"> 1. Severe scoring and heavy transfer of metal on end plates, rotor sides and vane ends. 2. No scoring or other damage to cam ring, vane edges or vane faces. | <p>Rotor Seizure</p> <ul style="list-style-type: none"> -Result of damage from other causes. -Lack of rotor clearance due to excessive pressure or tolerances. | <ol style="list-style-type: none"> 1. Check for any indication of other types of damage. If found, refer to check list for that type of damage. 2. If no other damage can be identified, check relief valve operation and pressure setting. |





| | |
|----------------------------------|--|
| ABRASIVE WEAR | Wear caused by abrasive action of dirt and fine contaminants in the oil |
| AERATED OIL | Presence of air bubbles in hydraulic oil...gives oil a foamy appearance |
| CAVITATION | Formation and collapse of vapor bubbles in hydraulic oil. |
| DIRT OR FINE CONTAMINANTS | Very small particles of abrasive material suspended in hydraulic oil. Usually not visible to the naked eye. |
| EROSION | Removal of metal particles from the surface of a part, leaving a rough, pitted area. |
| GALLING | To fret and wear away by friction or to become worn by rubbing. |
| GRAY VANES | Appearance of puma vanes scratched by dirt and fine contaminants. Rotor faces and end plates can have this same gray appearance. |
| HIGH OIL TEMPERATURE | Temperature above 200° F, when the oil film weakens and its lubricating ability is reduced. |
| INSERT VANE PUMPS | A hydraulic pump with vanes containing an insert. Pressure oil between the insert and the vane, in addition to centrifugal force, keeps the vane in contact with the cam ring. |
| INSUFFICIENT LUBRICATION | Inadequate oil film between vanes and cam ring, or between rotor, vanes and end plates. |
| LACK OF VANE CONTROL | Puma vanes become instable and cock in rotor spot. Wear on the cam ring results and also a milling of the end plates. |
| METAL CONTAMINANTS | Small particles of metal in the hydraulic oil. Probably have worn from components in the system and may or may not be visible to the eye. |
| OVERPRESSURE | Pressure in the system exceeds the specified relief valve pressure. |
| RING CHOP | Cam ring worn in a stairstep pattern. May be two or more steps 180° apart on the ring. |
| RING RIPPLE | Cam ring worn in a wavy pattern. Hills and valleys, typical of ring ripple, are about the same width and close together. May be five or more ripples per inch. |
| ROTOR SEIZURE | Galling between rotor and end plates with resulting transfer of metal from end plates to rotor. |
| ROTOR SLOT WEAR | Faces of rotor slot and vanes have worn until the rotor slot-vane clearance is greater than 0.05 mm. |
| WEAR AND PRESSURE PLATES | End plates on either side of the rotor. These and the cam ring form the pumping chamber and direct the oil in and out of the pump. Pressure oil on the outside of the pressure plate (usually thicker than the wear plate) holds the two plates and cam ring tightly together. |



SHAFT SEAL LEAKAGE

A) Is the seal leaking when pressurized?

- a-1) Check if the lips of the seal are not ruined (lack of lubricant leading to vulcanization of the rubber, external pollution...).
- a-2) Check if the shaft is not marked by a groove in the usual seal lip contact area.
- a-3) Check the shuttle valves.
- a-4) Check the pressure in the drain line on the motor. Long piping, elbows, small diameter, too high oil viscosity, other common drain flows in the same pipe can lead to high drain pressures.
- a-5) Check if there is no high overshoot at start-up that would create a high instant internal leakage.
- a-6) Check, when using a "rapid connector", if it is well locked.
- a-7) Check the alignment of the shafts.
- a-8) Check if there is no unbalanced driven load that could create a gap between the shaft and the seal.
- a-9) Check if the radial force is not too high (belt drives for example).

B) Is the seal leaking when standing still?

- a-1) Check if the seal is not damaged.
- a-2) Check if the shaft does not have any scratches.
- a-3) Check if the ball bearing is not ruined.
- a-4) Check if the drain line does not create a back pressure.





REAL IMAGES OF COMMON FAILURES

USE, MAINTENANCE AND REPAIR GUIDE



SQUARE PUMP BODY

SURFACE SCORING

This pump body surface is phosphate coated. It can be scored from pump seizure or severe contamination trapped between the rotor and body surface. The pump body on the left shows typical scoring. Such scored bodies can undergo minor resurfacing (.005" to .010"), but must be retreated (phosphated) before being returned to service. If major resurfacing is performed (.010" to .020" maximum), the O-ring groove must be deepened by an equal amount.

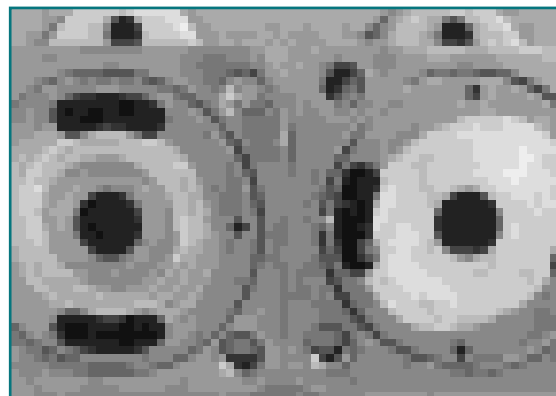

RESURFACING REQUIREMENTS

The body on the left (refer to photo to right) is scored badly enough to require resurfacing. The pump body surface on the right, however, has no depth of scoring—only the treatment colour has worn off. Bodies in this condition can be used "as is".

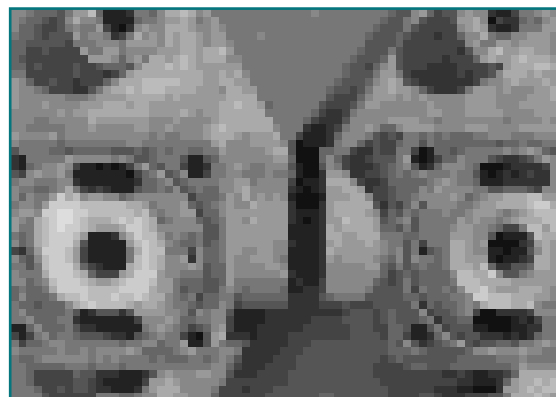

INTRA-VANE PUMP SUPPORT PLATE

INLET SUPPORT PLATES DAMAGES BY AERATION

The effects of aeration are similar on both inlet and outlet support plates. Here we see obvious damage caused by collapsed air bubbles. The plate surface is also badly scored. It can be resurfaced up to .010" without renotching or deepening the grooves. Resurfacing between .010" and .020" will require re-machining the groove depth and metering notches correspondingly. The resurfaced plates must be phosphate coated.



NO SIGNIFICANT DAMAGE

This outlet support plate shows no significant wear. After stoning to remove burrs, it can be reused.

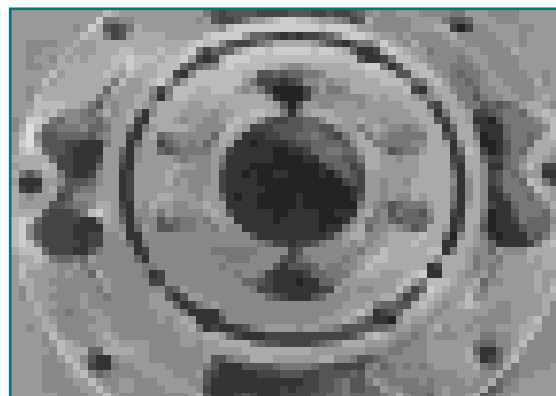



VQ PUMP FLEX PLATES

NORMAL DISCOLORATION

Flex plates play a key role in VQ pump operation. The bronze surface of these plates is critical to proper performance.

This flex plate displays a typical amount of discoloration. The discoloration alone should have no effect on pump operation.

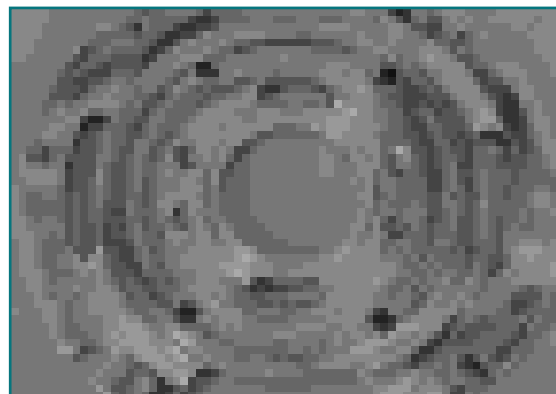

SEVERE AERATION DAMAGE

The erosion on the VQ flex plate was caused by collapsed air bubbles (aeration) near the outlet port metering notches. If the damage isn't too severe, the plate can be resurfaced to a maximum .005". The flex plate to the right is damaged beyond repair.

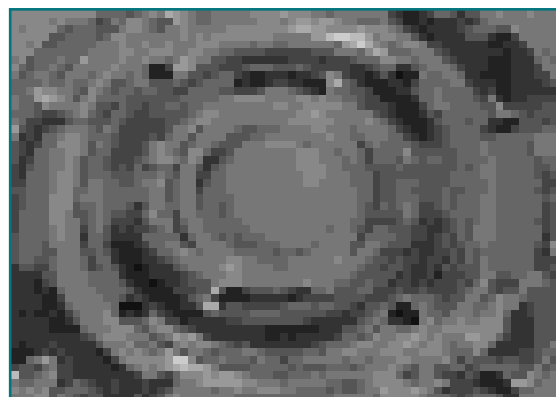

DARKENING AND EROSION

Damage as shown here is the result of excessive system temperature. After this problem in the system has been corrected, the entire cartridge must be replaced.





SQUARE PUMP PRESSURE PLATE

SIGNS OF PUMP AERATION

Because air is compressible, any bubbles trapped between the vanes of a pump are violently imploded when subjected to outlet pressure. If an imploded air bubble is near a pump surface, the energy released can remove material. This leaves cavitation-type pock marks (as seen here at the outlet metering notches). The particles of metal blasted away become fine contamination that can cause wear and scoring of the pressure plate and mating rotor failure. Pumps surfaces with mild aeration and cavitation marks can be resurfaced up to .010". If more than .010" is removed during resurfacing, the metering notches must be renotched by the same amount. Any bearing or guide surfaces that are ground should always be lapped or polished to improve surface texture. After resurfacing, a phosphate coating must be applied.

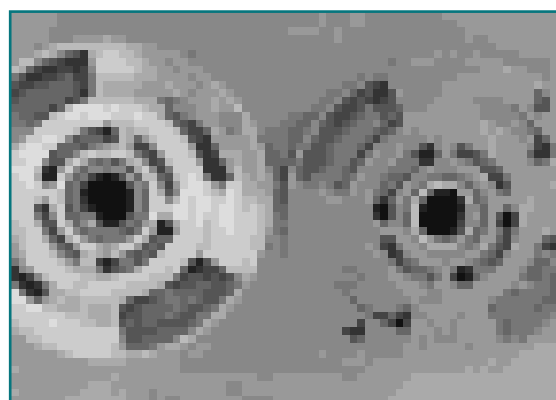

SEVERE AERATION DAMAGE

The pressure plate on the left has suffered severe damage from aeration and is beyond repair. Resurfacing would fail to restore the material that's been chipped away near the metering notches. (The plate on the right is in good condition and is shown for comparison).

VANE PUMP VANES

VANE FROSTING

Compare the appearance of the vane (bottom) with the frosted look of a vane that's been subjected to fluid contamination (top). The cartridge this vane came from must be replaced.

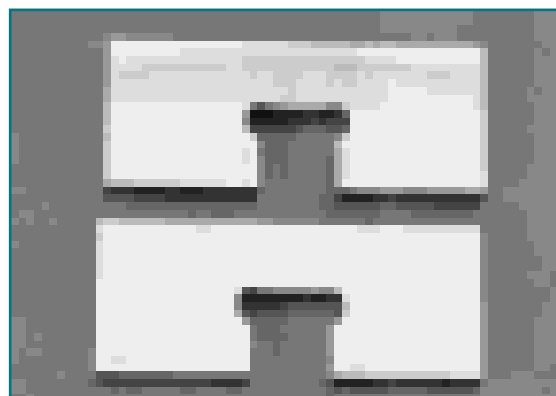

TIP WEAR

The vane on the left is new. The vane in the middle is worn down from the fluid contamination. The extreme wear seen on the vane to the right was caused by aeration. Similar damage can also be caused by fluid in poor or marginal condition. The associated cartridge must be replaced.

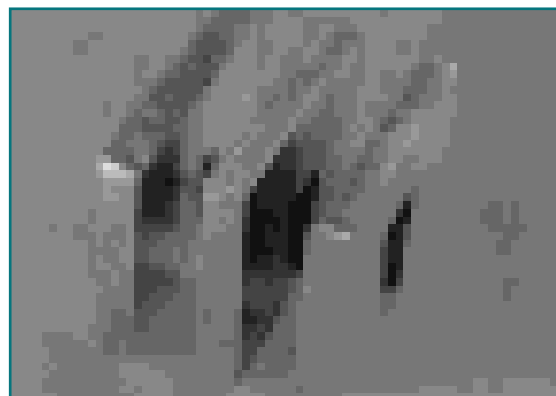

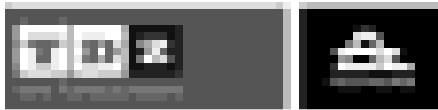

VANE PUMP VANES

GALLED VANE

This type of galling damage is symptomatic of over-pressure or over-temperature. This indicates a cartridge damaged beyond repair.

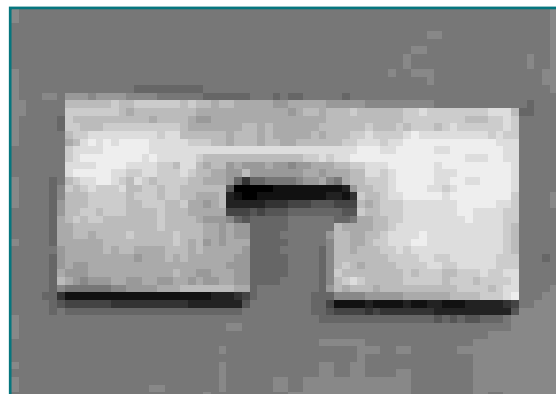

ROTOR PUMP VANES

TYPICAL SEIZURE DAMAGE

Seizure type failures can be due to fluid contamination, dry run, lack of lubricity in the fluid, high system temperature, or improper clearance between cam ring and rotor thicknesses. Rotors with vane slots worn more than .0002" cannot be reused. Rotors with scored surface like the one shown here cannot be reworked and must be replaced.

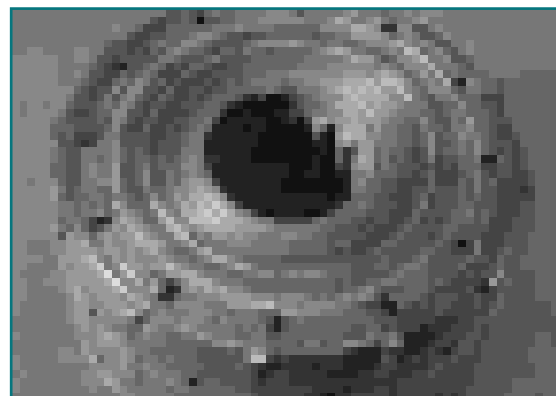

ROTOR SMEAR

Rotor surfaces can be badly scored by contamination and/or seizure. Vane slots can also become worn or scored by fluid contamination.

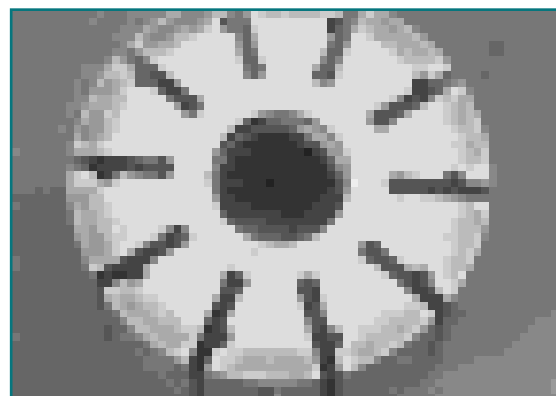



VANE PUMP CAM RING

COMPARISON OF TWO FAILED CAM RINGS

The ring on the left has mild rippling and can be used again. The one on the right, however, has decomposed badly from extreme heat and shows evidence of pump seizure. It must be replaced.



SEIZURE DAMAGE

Pump seizures (as evidenced by galling or metal transfer) can make local temperatures rise dramatically. These high temperatures cause discoloration of the cam ring, as seen here. The local temperature was so high that the vane tips literally fused into the ring contour. A ring in this condition cannot, and should not, be reworked).



RIPPLE MARKS

Vane pump cam ring will have a shiny inner surface due to normal operation. Some rings (as seen here) may also exhibit ripple marks caused by cavitation, aeration or contamination. These marks can vary from minor to severe. Mild ripples can be polished out and the ring reused. Always polish the cam ring in the indicated direction of rotation. Heavy rippling requires expert examination to determine whether geometrical grinding can be used to salvage the ring. Nital etching should also be performed to ensure that the surface is not softened.



HEAT CHECKED SURFACE

This appearance indicates one or more system problems including excessive temperature, marginal fluid quality or an aerated inlet. Heat checked cam rings must be replaced.

Cam rings can crack or break completely at their weakest cross sectional point. This type of failure is caused by pressure surges beyond the pump's design specification.

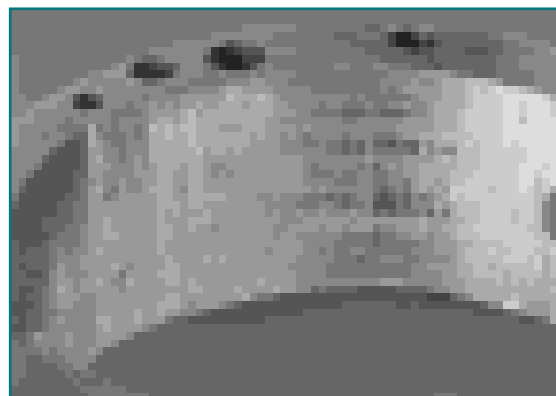



VANE AND PISTONS PUMP SHAFTS

Pump shaft failures are generally caused by repeated stress. Like a chain that is only as strong as its weakest link, shaft damage will occur when the stresses encountered at the weakest link, shaft damage will occur when the stresses encountered at the weakest point of the shaft finally exceeds its strength.

ROTATIONAL BENDING FATIGUE

The shaft above broke cleanly at a 90 angle to its axis of rotation.

This type of failure is due to rotational bending fatigue. A likely cause is misalignment between the pump and its "prime mover" that makes the shaft flex slightly with each revolution. Fractures like this usually start in some area of concentrated stress that is at least partially perpendicular to the shaft axis. These weak points in the shaft can include grooves, fillets, and holes. The shaft shown here has the ripple marks typically found with rotational bending fatigue failures. These marks indicate that the shaft was unevenly loaded or unbalanced. The smoother area near the edge is where the fracture started. The curved ripples get gradually courser, with a rough, shell-like spot where the shaft finally ruptured.

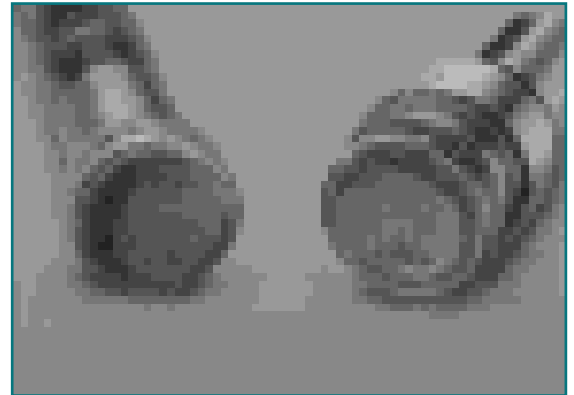

TORSIONAL FATIGUE

Seizure type failures can be due to fluid contamination, dry run, lack of lubricity in the fluid, high system temperature, or improper clearance between cam ring and rotor thicknesses. Rotors with vane slots worn more than .0002" cannot be reused. Rotors with scored surface like the one shown here cannot be reworked and must be replaced.

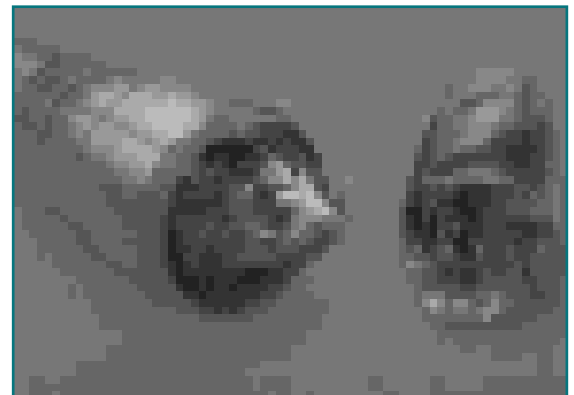



Pump Start up
Pump Identification
Assembly & Disassembly
Change of ports configuration
Change of Cartridge rotation
Pump and cartridge manipulation & repair

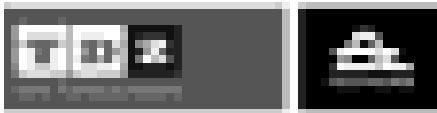

PUMP START-UP PROCEDURE

Preparation Prior to Start-up

The reservoir and circuit should be clean and free of dirt and debris prior to filling with fluid.

Circuit Cleanup

The reservoir should be charged with filtered hydraulic fluid. The fluid level should be sufficient to prevent vortexing at the suction connection to the pump inlet. It is good practice to clean the system by flushing and filtering, using an external slave pump.

Filling Pump and Removing Air

If the pump is mounted above the fluid level, it should be filled with fluid through the outlet port.

If the pump is mounted below the fluid level, the pump outlet fitting (or other downstream fitting or plug) can be loosened to allow fluid to displace the air. It may be necessary to loosen the fill cap on the reservoir to allow the fluid to flow freely. When a solid stream of fluid with no observed air begins to drain through the loosened fitting, the fitting should be retightened.

An air bleed valve in the outlet circuit is also recommended to remove trapped air. If such a device is used, the pump should be filled with fluid before start-up.

In some cases, it may be possible to prime the pump by running the engine starter for five to ten seconds with the throttle and/or ignition switch in the "off" position. It will be necessary to loosen a fitting or plug in the pump outlet to allow air to escape.

Pump Start-up

All controls should be placed in the neutral position so the pump is unloaded when started.

Start the engine and run at low idle.

Once the pump is started, it should prime and pump within a few seconds. If it does not, make sure there are no restrictions between the reservoir and the inlet to the pump, and that there are no air leaks in the inlet line and connections. Also, make sure that trapped air can escape from the outlet.

Run at low engine idle for approximately five minutes. Then, while observing the reservoir fluid level, operate the implements. Extend all actuators to maximum safe limits to completely fill the system with fluid.

Do not run with the fluid level below the "low" limit.

Add fluid to the reservoir to bring the fluid to the proper fill level.





IDENTIFICATION

Due to the difficulty in finding out spare cartridge references, either for the loss of the pump feature plate, or for the lack of the machine spare part catalogue, it is most convenient to include some sheets to identify the sample accurately and to give some advice for a correct assembly.

To identify properly cartridge and pump, use the 3 following pages as follows:

- DIMENSIONS AND FLOW

Find out pump type and flow in the dimensions chart, look at the figure engraved on the rings as shown (gallons/-min. at 1200 rpm).

- SUPPORT BUSHING AND SHAFT ROTATION

Locate support bushing to know whether the cartridge belongs to a single or double pump. On this page there are also some clues to identify shaft rotation.

- PUMP MODEL, SHAFT TYPE AND PORT POSITION (SEE OUR TECHNICAL CATALOGUE)



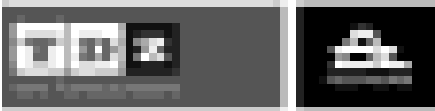

IDENTIFICATION

DIMENSIONS AND FLOW

V* Series Cartridge Kit

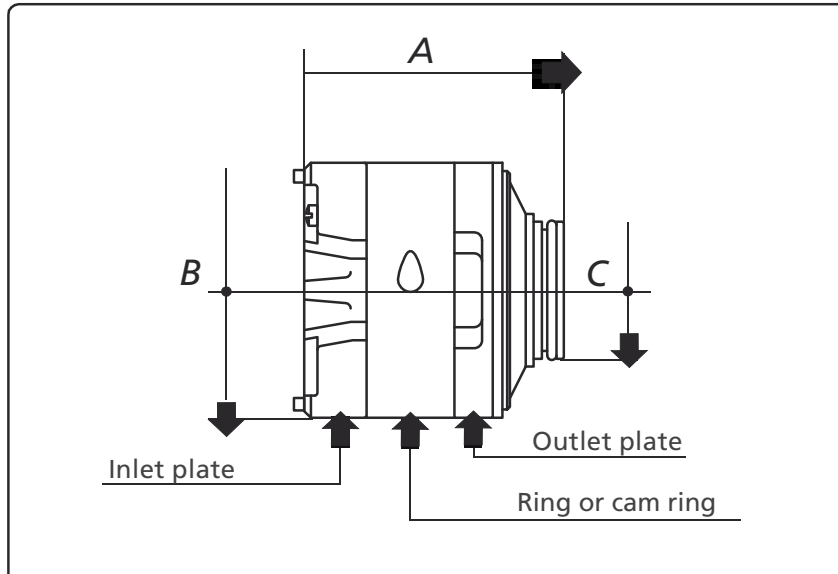

| DIMENSIONS In mm. | PUMP TYPE | | | | |
|-------------------------------------|-----------|-------|-------|--------|--------|
| | 20V | 25V | 30V | 35V | 45V |
| A | 81,8 | 99,5 | 110,5 | 118,4 | 140,5 |
| B | 82,6 | 96,8 | 96,8 | 114,25 | 133,3 |
| C | 47,15 | 52,15 | 52,15 | 72,15 | 80,15 |
| WEIGHT aprox. in Kg. | 2,300 | 3,800 | 4,100 | 6,400 | 10,200 |
| FLOW in Gal. at 1.200 rpm | 2 | 8 | 24 | 21 | 42 |
| | 5 | 12 | 28 | 25 | 47 |
| | 8 | 14 | | 30 | 50 |
| | 9 | 17 | | 35 | 57 |
| | 11 | 19 | | 38 | 60 |
| | 12 | 21 | | 45 | 67 |
| | 14 | 24 | | | 75 |
| | | 27 | | | |

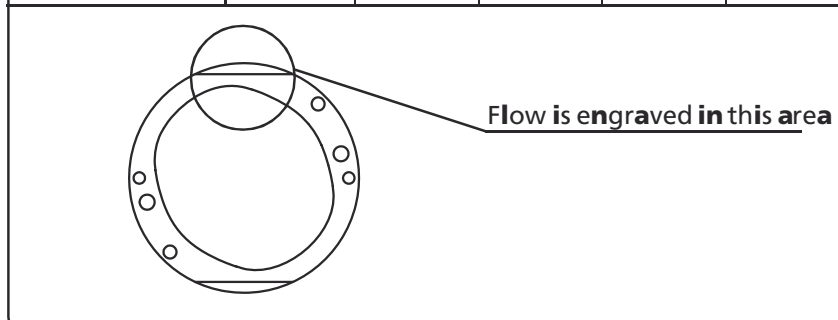

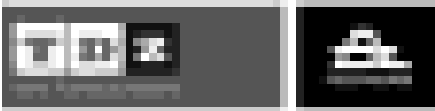

IDENTIFICATION

DIMENSIONS AND FLOW "DT6" SERIES CARTRIDGE KIT

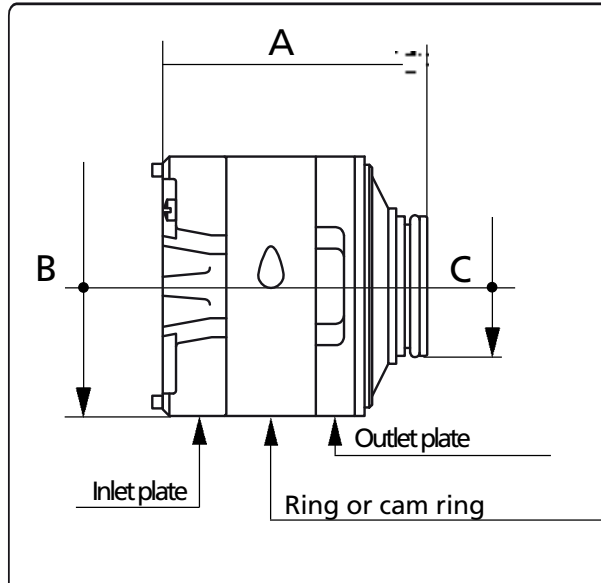

| DIMENSIONES en mm. | PUMP TYPE | | |
|-------------------------------------|-----------|-------|--------|
| | DT6C | DT6D | DT6E |
| A | 105 | 132,7 | 149,3 |
| B | 95,2 | 123 | 143,1 |
| C | 61,9 | 71,9 | 87,9 |
| WEIGHT aprox. in Kg. | 3,500 | 7,800 | 12,200 |
| FLOW in Gal. at 1.200 rpm | 3 | 14 | 42 |
| | 5 | 17 | 45 |
| | 6 | 20 | 50 |
| | 8 | 24 | 52 |
| | 10 | 28 | 62 |
| | 12 | 31 | 66 |
| | 14 | 35 | 72 |
| | 17 | 38 | 85 |
| | 20 | 42 | |
| | 22 | 45 | |
| | 25 | 50 | |
| | 28 | | |
| 31 | | | |

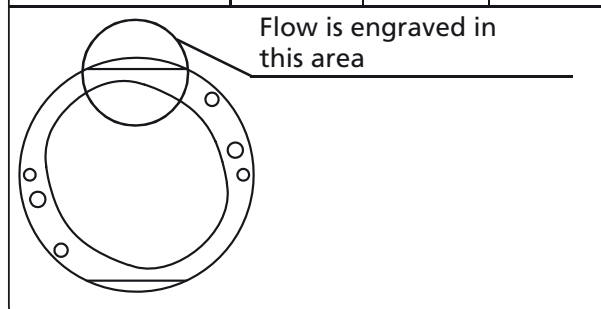

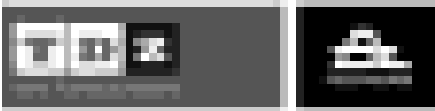

IDENTIFICATION

DIMENSIONS AND FLOW BHP Series Cartridge Kit

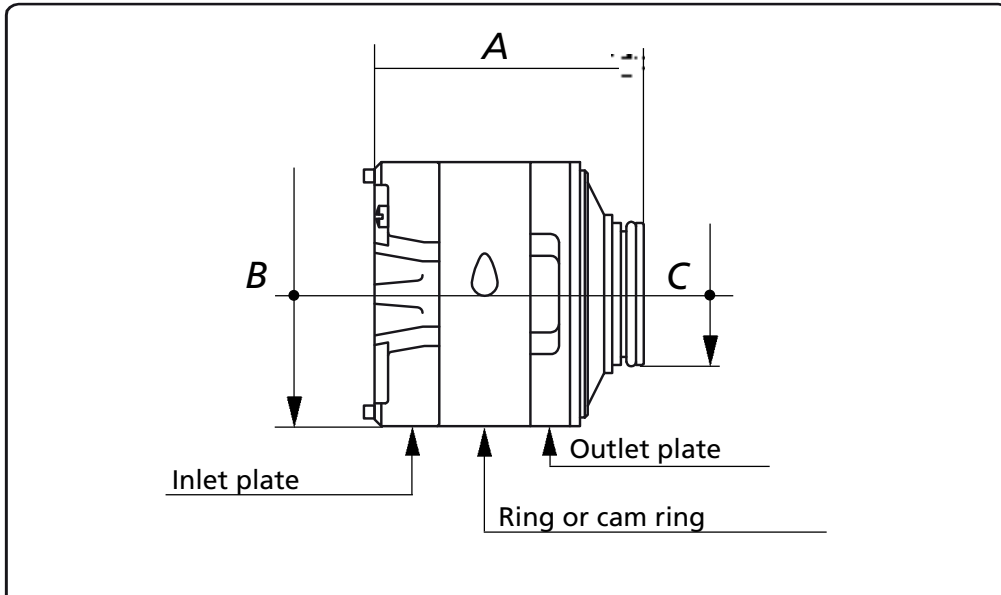

| DIMENSIONS in mm. | PUMP TYPE | | | | | |
|------------------------------------|-----------|-------|-------|-------|--------|--------|
| | BHP1 | BHP2 | BHP3 | BHP4 | BHP6 | BHP7 |
| A | 42,7 | 61 | 80,4 | 99,5 | 118,4 | 140,5 |
| B | 49,9 | 61,9 | 81,1 | 96,8 | 114,25 | 133,3 |
| C | 28,1 | 29,8 | 47,8 | 52,15 | 72,15 | 80,15 |
| WEIGHT aprox. in Kg. | 0,450 | 0,900 | 2,200 | 3,800 | 6,400 | 10,200 |
| FLOW in Gal. at 1.200rpm | 0,6 | 2,2 | 2 | 8 | 21 | 42 |
| | 0,9 | 2,5 | 5 | 12 | 25 | 47 |
| | 1,2 | 3,2 | 6 | 14 | 30 | 50 |
| | 1,7 | 3,8 | 8 | 17 | 35 | 57 |
| | 2 | 4,7 | 9 | 19 | 38 | 60 |
| | | | 11 | 21 | 45 | 67 |
| | | | 12 | 24 | | 75 |
| | | 16 | 27 | | | |

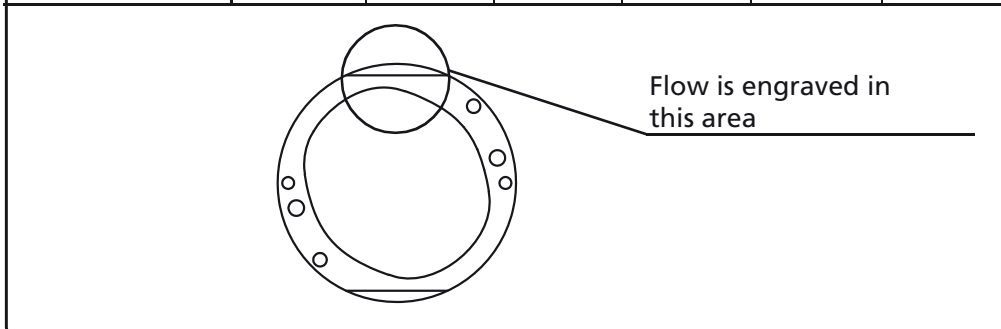



IDENTIFICATION

PUMP ROTATION Single Pumps

To determine pump rotation look at it from the shaft end side. If clockwise it is right hand rotation, on the contrary, it is left hand rotation.

When taking out cartridge and putting it on to the outlet plate take into account that rotation is seen the other way round; anyway, an arrow engraved in the ring or cam ring shows the real turning sense. (See pictures.)

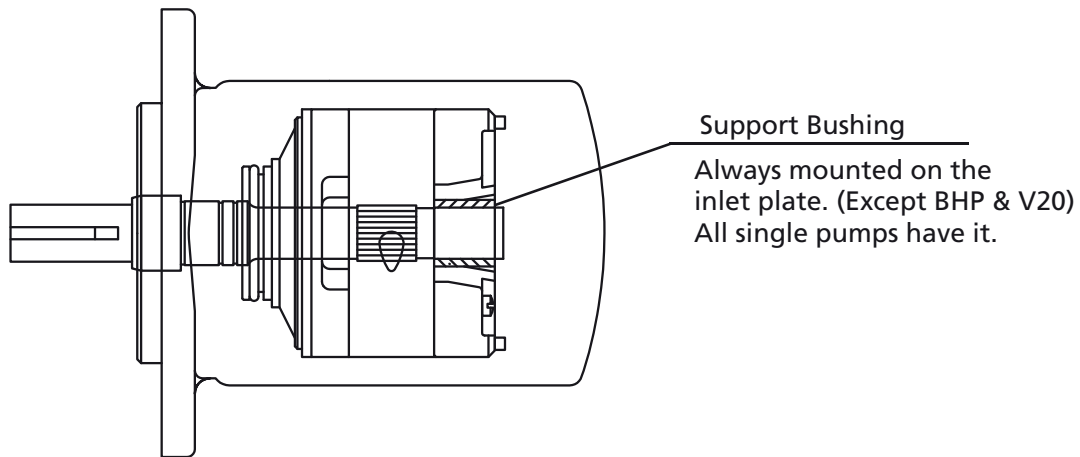

Pump rotation is viewed from the shaft end side.

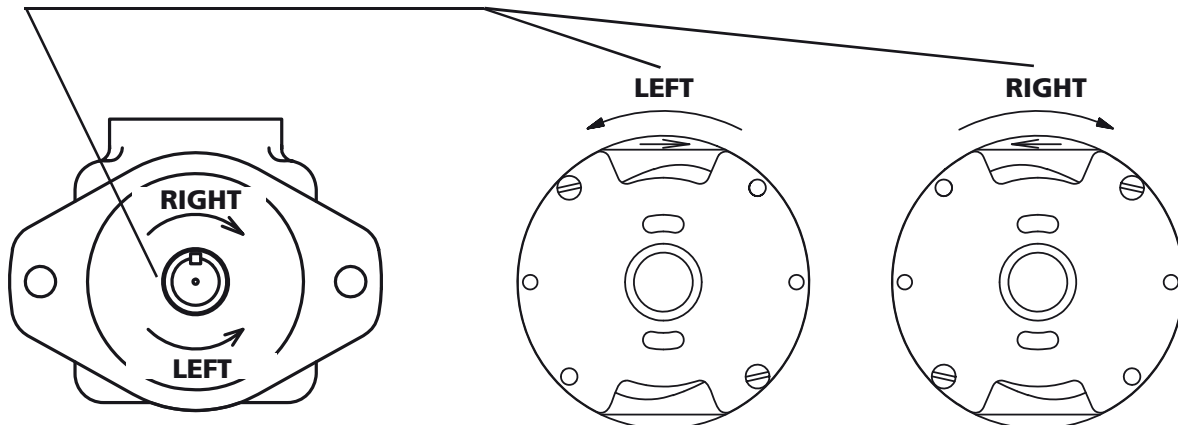

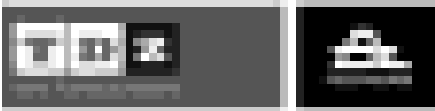

IDENTIFICATION

PUMP ROTATION Double Pumps

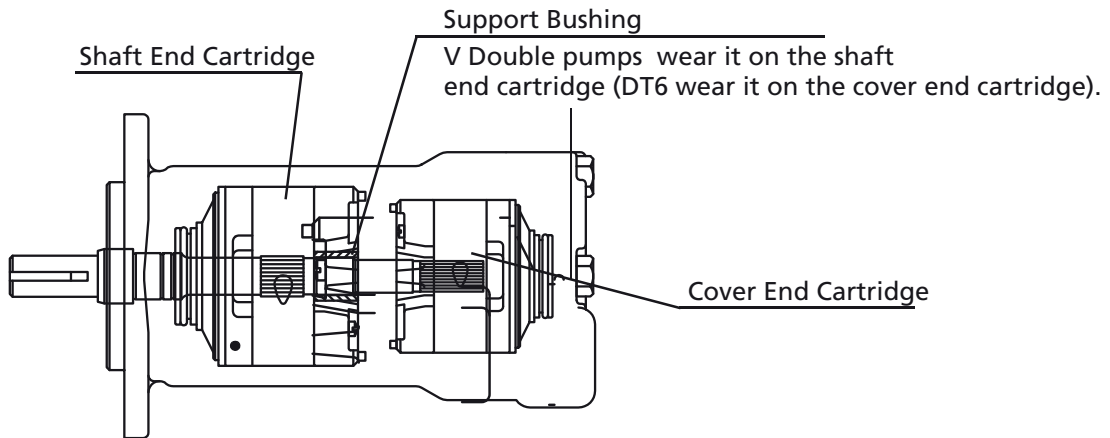

Double pump special feature is that their 2 cartridges are opposite each other, therefore when putting them on the outlet plate, they will apparently have opposite turning sense. Anyway, the arrow in the ring shows the correct rotation. (Pump and cover end cartridge rotation always coincide.)

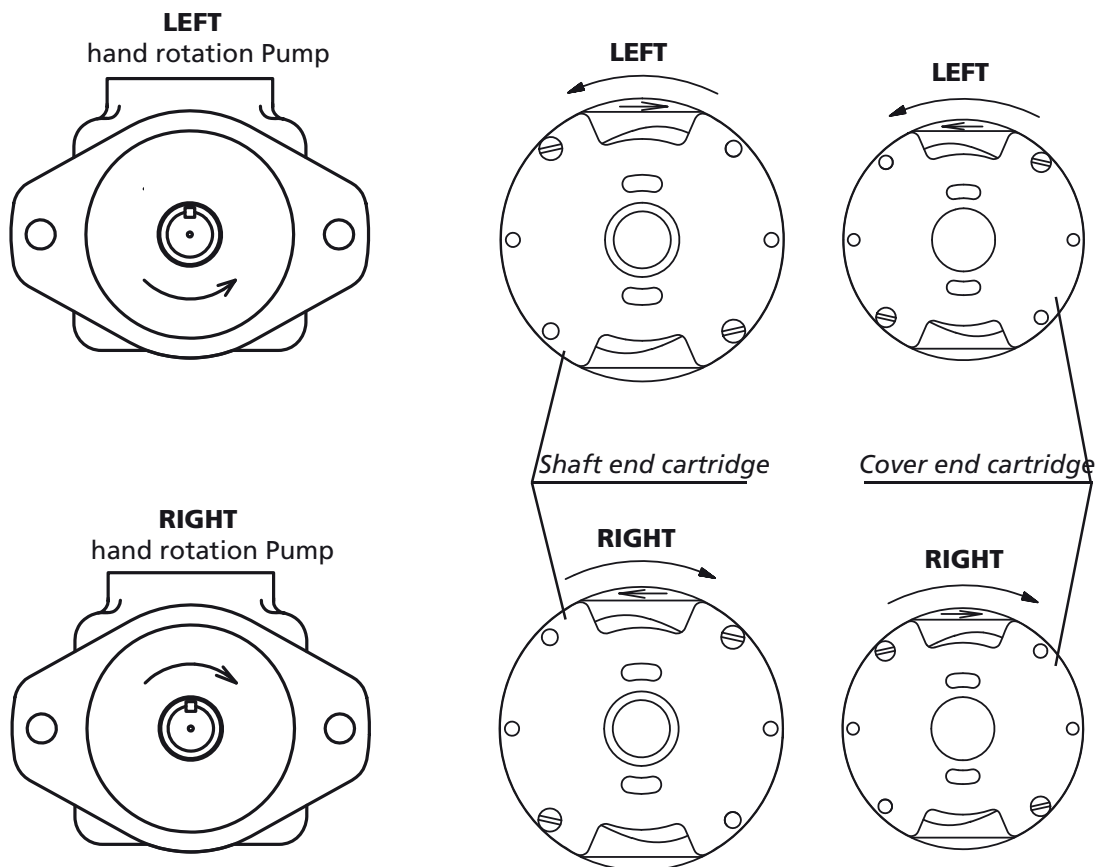

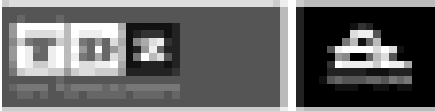

IDENTIFICATION

PUMP ROTATION - TRIPLE PUMPS

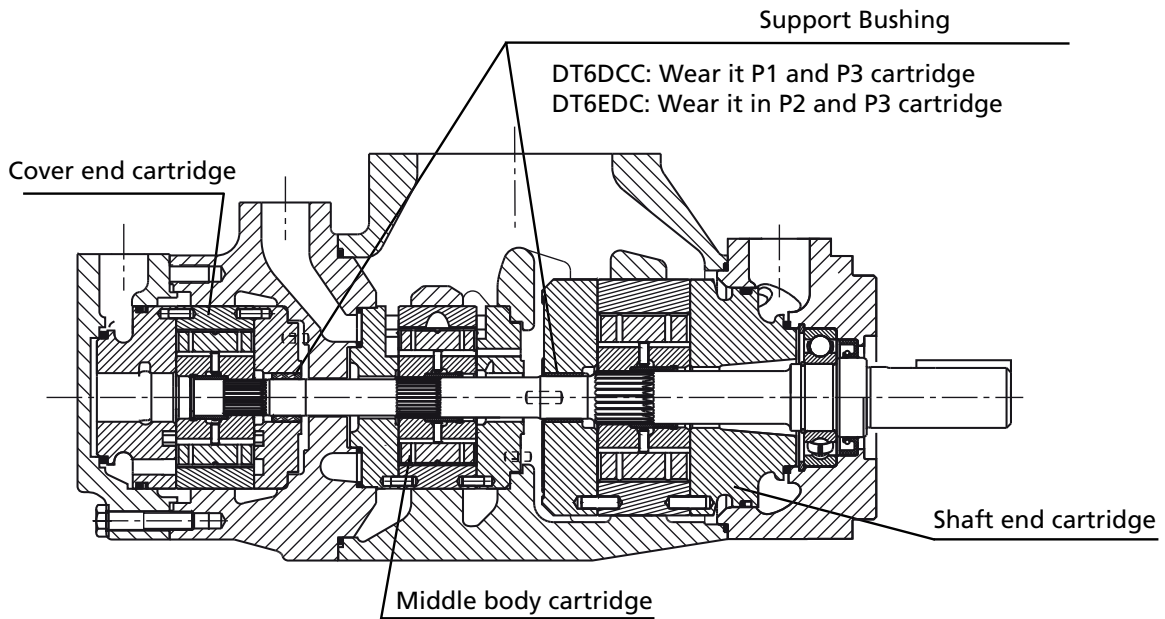

Triple vane pump special feature is that shaft end cartridge is mounted opposite to the middle and cover end kits. Pump, middle cartridge and cover end cartridge rotation always coincide.

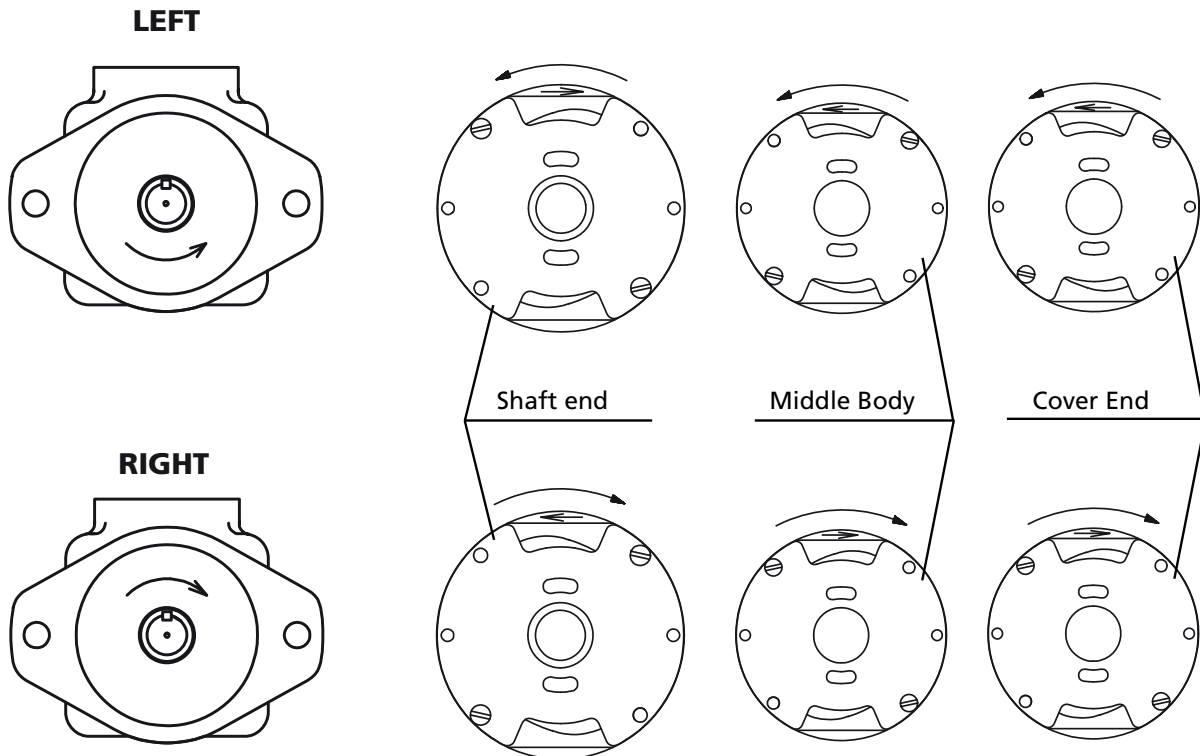

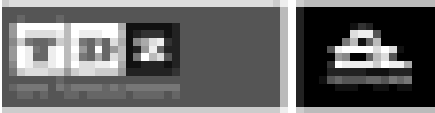

ASSEMBLY & DISASSEMBLY - CHANGE OF PORTS COFIGURATIONS

Vane pumps have a different external configuration, depending on the position of the suction flange (located on the pump cover) in relation to the pressure flange (located on the coupling flange or shaft side).

The suction flange may be in line with the pressure flange, (0°), 90° to the right, 90° to the left or totally opposite it (180° in relation to the pressure flange).

The steps to modify the position of the suction flange in relation to the pressure flange are as follows:

1- Secure the pump to a workbench and loosen the four bolts joining the pump cover to the front body (or shaft-side body).

2- Do not fully remove the bolts. Remove approximately half their total length for the pump body.

3- Remove the front body cover just 1 mm - 2mm, (maximum) by slightly turning the cover and pushing it outwards.

4- Using a sufficiently long, resistant metal bar, support it obliquely on two diagonally opposite screws and lever, making the cover turn until the suction flange is in one of the four aforementioned positions.

5- Readjust the cover and the 4 bolts with the appropriate torque. Make sure that no particles of paint or other material are between the body and the cover and that the o-ring housed between these two parts is not pinched when tightened.

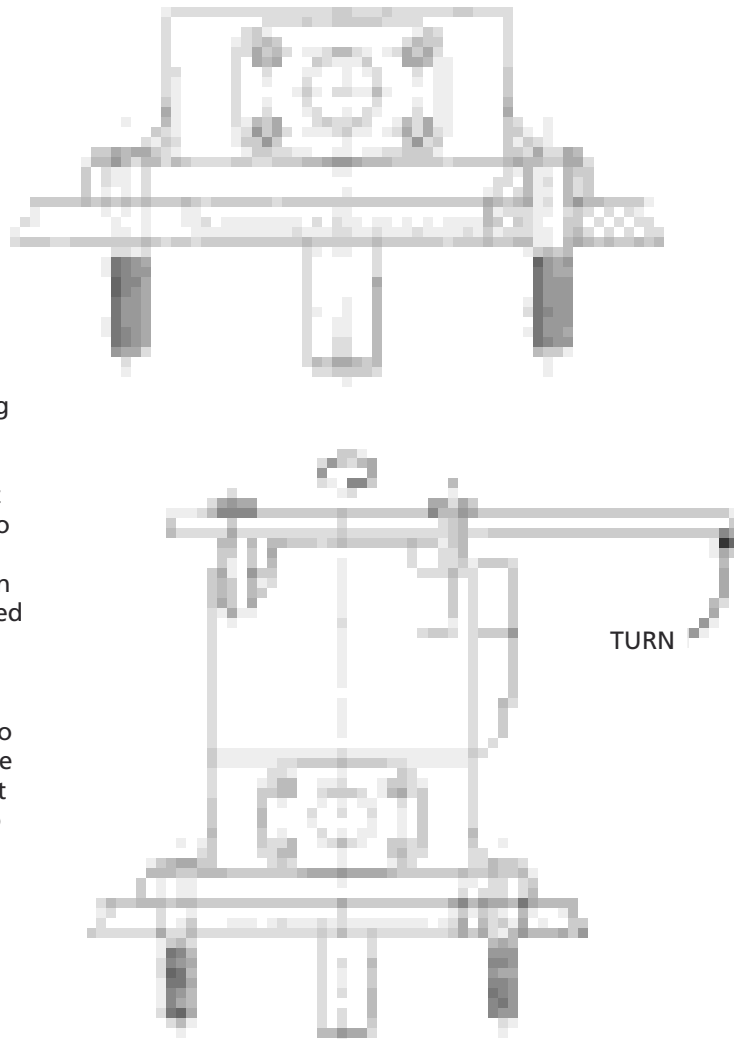

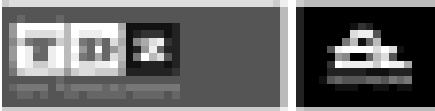

ASSEMBLY & DISASSEMBLY

TIGHTEN TORQUE FOR SINGLE PUMP SCREWS

| | Reference | Tighten torque in Kp.m. |
|---------------------|-----------|-------------------------|
| SINGLE PUMPS | 20V | 6,5 |
| | 25V | 10,5 |
| | 35V | 22,5 |
| | 45V | 35 |
| | BHP1 | 1 |
| | BHP2 | 2,5 |
| | BHP3 | 5 |
| | BHP4 | 10,5 |
| | BHP6 | 22,5 |
| | BHP7 | 35 |
| | DT6C | 16 |
| | DT6D | 19 |
| | DT6E | 19 |

Tighten the screws with a torque no bigger than 0,5 to 1 Kp.m before beggining the last or final tighten.
Follow the order shown in the picture.

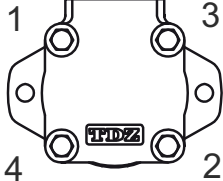

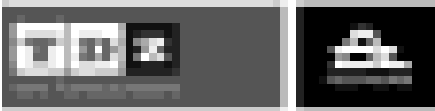

ASSEMBLY & DISASSEMBLY

TIGHTEN TORQUE FOR DOUBLE PUMP SCREWS

| | Reference | Inletbody | Cover |
|---------------------|-----------|-----------|-------|
| DOUBLE PUMPS | V*43 | 10,5 | 6,5 |
| | V*63 | 22,5 | 6,5 |
| | V*64 | 22,5 | 10,5 |
| | V*73 | 35 | 6,5 |
| | V*74 | 35 | 10,5 |
| | V*76 | 35 | 35 |
| | VC2010 | 7 | 7 |
| | VC2020 | 12 | 12 |
| | DT6CC | 16 | 6 |
| | DT6DC | 19 | 7 |
| | DT6EC | 19 | 7 |
| | DT6ED | 19 | 19 |

Rear flange mountings of the V**T* thru drive pumps.

Tighten torque for pump screws: 6,5 K.p.m.

Tighten the screws with a torque no bigger than 0,5 to 1 Kp.m before begging the last or final tighten.
Follow the order shown in the picture.



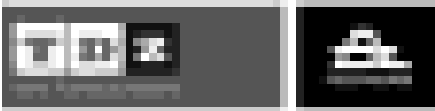

ASSEMBLY & DISASSEMBLY

TIGHTEN TORQUE FOR TRIPLE PUMP SCREWS

| | Reference | Inletbody | Cover 1° | Cover 2° |
|---------------------|-----------|-----------|----------|----------|
| TRIPLE PUMPS | DT6DCC | 19 | 19 | 7 |
| | DT6EDC | 30 | 19 | 6 |

Tighten the screws with a torque no bigger than 0,5 to 1 Kp.m before beginning the last or final tighten.
Follow the order shown in the picture.



CHANGE OF CARTRIDGE ROTATION

The cartridges on this type of pump available worldwide can be unidirectional or bidirectional. Rotation on unidirectional cartridges cannot be modified, except where the cartridge pressure plates are replaced for others with an opposite turning direction or for bidirectional plates.

TDZ cartridges are bidirectional. This means that rotation can be modified by means of a simple operation using exactly the same cartridge components that are to be modified.

The steps to follow are as indicated:

1.- Remove the 2 set screws from the cartridge.

2.- Remove the cartridge suction cover. Of the two cartridge covers, the suction cover is the flattest and may be fitted with a bronze bearing, depending on the position of the cartridge on the pump (P1, P2 or P3). Next to the cover there are 1 or 2 position pin that should also be removed.

3.- Remove the cam ring or stator and turn 180° so that side "A" of the stator that was previously in contact with the surface of the suction cover is now touching the pressure cover and side "B" of the stator that was previously in contact with the pressure cover is now touching the suction cover.

Above mentioned instructions are valid for DT6 series only. V* series change of rotation should follow the same procedure but cam ring, rotor and vanes should turn 180° As a complete package (V* series rotor and vanes are not simetric)

4.- Change the positioning or (2 pins in V series) pin on the pressure cover from hole "A" to hole "B" and re-insert the stator so that the stator hole matches the new position of the pin.

Length and quantity of pins (1 or 2) depends of cartridge series (DT6, VS or VQ).

5.- Also change the position pin on the suction cover and readjust the cover using the two screws. Turn the rotor and the blades manually before tightening the screws.

Attentions: The screws are basically for alignment purposes. They must not be too tight. If the three parts of the cartridge (stator, suction cover and pressure cover) are not perfectly concentric, it will be impossible to insert the cartridge into the pump housing.

In this case, loosen the screws slightly and insert the entire cartridge into the body of the pump. When it is fully inserted is when the cartridge parts are fully aligned and the screws can be readjusted.



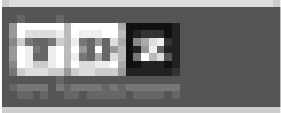

CHANGE OF CARTRIDGE ROTATION (EXAMPLE VQ SERIES)

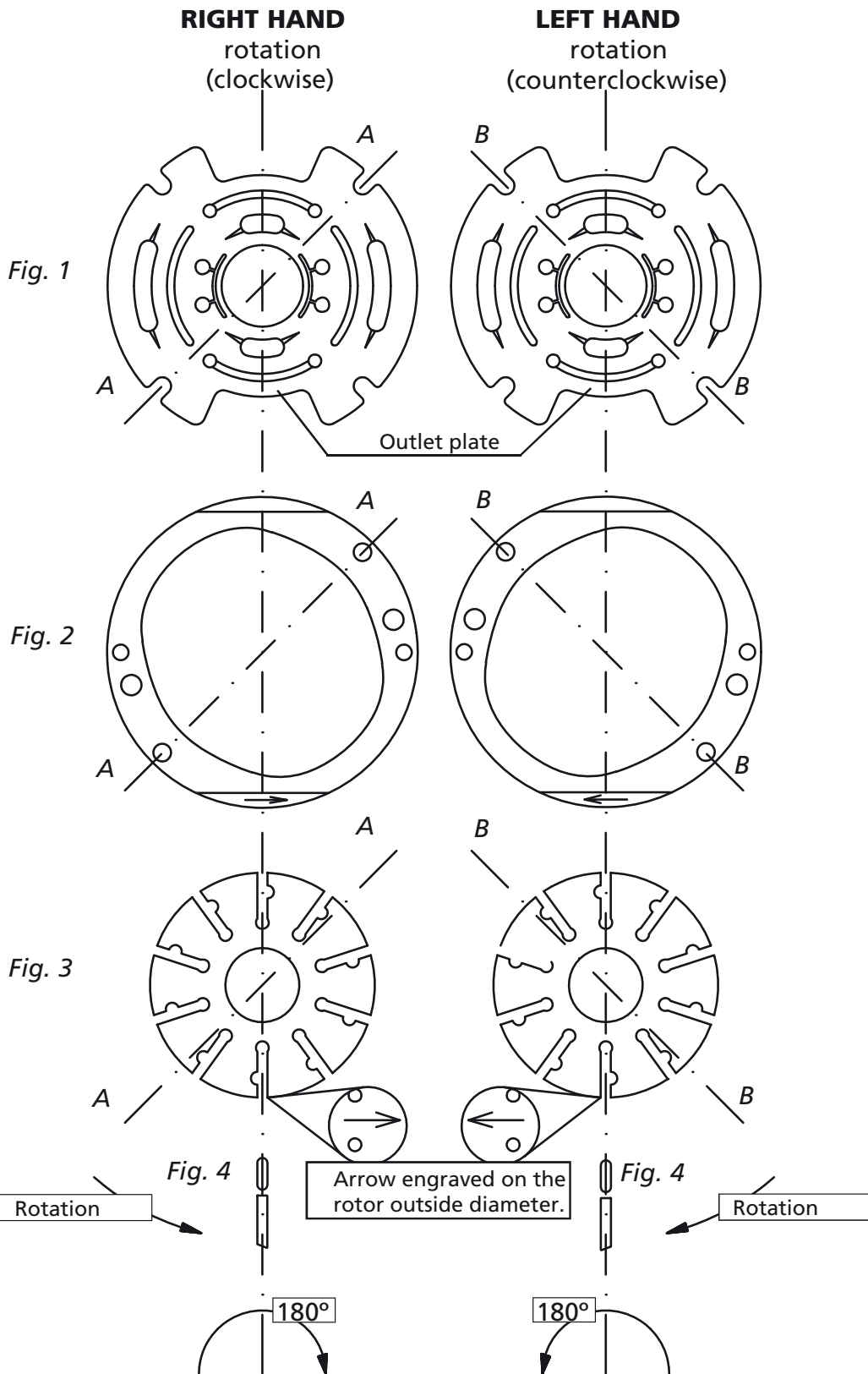



RECOMMENDATIONS FOR PUMP AND CARTRIDGE MANIPULATIONS

Since this is a high precision kit (mechanized in tolerances within thousandth of millimeter), any abrasive impurity can damage it in a few minutes or damage it to shorten its performance, before disassembling it is necessary that working place, tools and worker hands are completely clean and neat.

Please avoid any blow, however insignificant, taking special care with all edge sides, ring seat points and inlet and outlet plates.

All these preventive measures taken, proceed as follows:

- 1°** Lean the cartridge, holding it tightly, at the work bench on the outlet plate. Loosen the 2 screws which fix the kit, take them out as well as the pins (if there are any).
Take out inlet plate shifting it laterally, as due to the protective oil it may be gummed up. Place it at the bench on a clean paper, white preferably.
- 2°** Do the same with vanes, rotor and ring.
Place the rotor, once disassembled, onto the outlet plate with arrow showing the required turning sense (see detail in the circle, fig. 3), afterwards, put inserts into vanes (fig. 4), and finally, introduce them in the slots, well at the bottom, with vane closing edge in forward rotation, as arrow shows in the corresponding picture. (V* Series only)
- 3°** Be sure there is no small dirty particles on the leaning surface, put ring on to the outlet plate, placing it in the required turning sense. Make chamfer edge coincide, in which flow and arrow are engraved, with inlet or admission port.
- 4°** Set inlet plate, pins and the 2 screws as shown in the pictures, taking into account that the lattes must be in opposite position to the ones they had before disassembling. (To do so, just turn ring, rotor and vanes 180°). Fasten the screws moderately and dip the whole cartridge kit into clean hydraulic oil for a while. After these steps it is ready to be assembled.

Please pay good attention to the cartridge and pump rotation, as they do not always coincide. Be very careful to identify them properly. (See previous pages.)





RECOMMENDATIONS FOR PUMP AND CARTRIDGE REPAIRS

CARTRIDGE REPLACEMENT

To successfully replace cartridge, be sure to follow these warnings:

1° - Check if due to use there is tread on the cartridge seat zone (dark area in the picture).

If so, deepness must not be higher than 0,01 mm. (This could be observed even with a fingernail), being most convenient in such cases grinding or changing the pump body with this fault, as otherwise noise and performance values will not be the right ones. (In case you can not grind the seat, TDZ has -available for sale- a simple machine specially designed for this purpose).

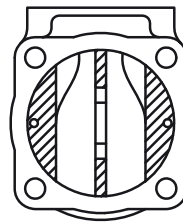

2° - Look at the cartridge to be replaced, if wear is normal just change oil in tank circuit and change or clean filters.

3° - Should the used cartridge shows seizure in rotor, outlet & inlet plates, disassemble the pump completely. Check that the key is in good condition (it could be cut out). Then, put the shaft between points to make sure it is not twisted or crooked. Change it in case of any fault. Take all the oil out of the circuit and other parts. Clean the tank carefully. If there is available any used cartridge mount it and start the machine for at least 15 minutes, driving all controls. To do so, spend the least possible amount of oil, since it will have to be replaced after this operation, although it could be reused again, after being filtrated in a filter no bigger than 5 microns, as it still keeps additives).

Replace or clean all filters, mount the new cartridge and fill the tank to the level with new oil. Follow all start-up indications in this manual.

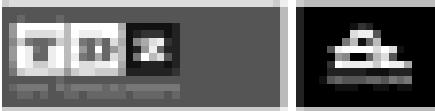

RECOMMENDATIONS FOR PUMP AND CARTRIDGE REPAIRS

CARTRIDGE REPAIRS MINIMAL CLEARANCE BETWEEN CAM RING AND ROTOR

| MODEL | Inches | Millimetres |
|-------|--------|-------------|
| 20VE | 0.0007 | 0,018 |
| 20VA | 0.0007 | 0,018 |
| 25V | 0.0012 | 0,030 |
| 30V | 0.0014 | 0,035 |
| 35V | 0.0015 | 0,038 |
| 45V | 0.0016 | 0,040 |
| BHP1 | 0.0001 | 0,004 |
| BHP2 | 0.0001 | 0,004 |
| BHP3E | 0.0005 | 0,015 |
| BHP3A | 0.0007 | 0,018 |
| BHP4 | 0.0012 | 0,030 |
| BHP6 | 0.0015 | 0,038 |
| BHP7 | 0.0016 | 0,040 |
| DT6C | 0.0011 | 0,030 |
| DT6D | 0.0014 | 0,038 |
| DT6E | 0.0017 | 0,044 |

* Vane length must be from 0,005 to 0,010 mm. (0,0002 to 0,0004 inches) less than rotor thickness.

To rebuild cartridges it is necessary to use grinding & lapping machines, as well as measurement tools able to work in microns.





FOT. 1938



FOT. BILCOMA/2014

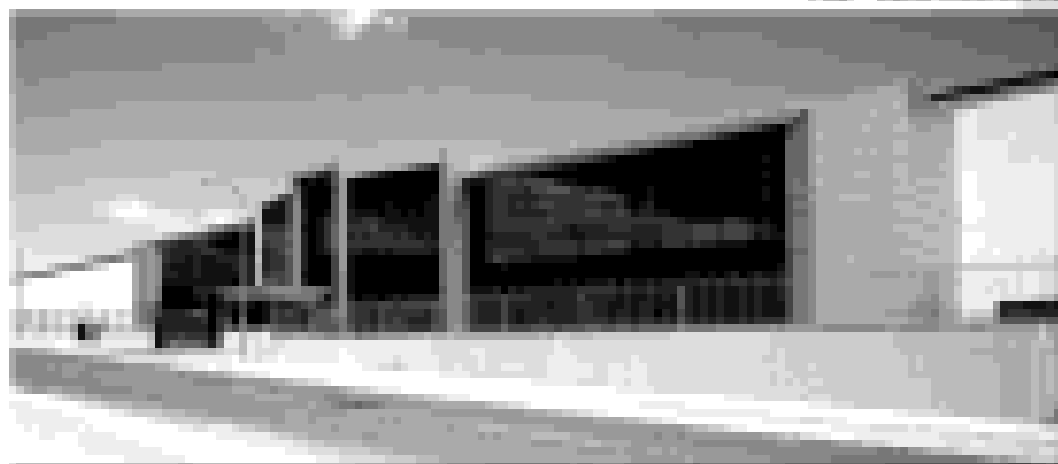

v. L'Espresso-Costa, 16
00187 - Roma (Italia)

T. +39 06 52 00 00
R. +39 06 52 00 00

e-mail info@l'espresso.com
www.l'espresso.com



GRUPPO EDITORIALE L'ESPRESSO

Pal. Inv. Montefiore
viale Las Piapesse, 145
00187 - Roma (Italia)

T. +39 06 8 98 92 92

e-mail info@gruppoeditorialel'espresso.com
www.gruppoeditorialel'espresso.com