

www.khadamathydraulic.com

Tell: 021-55882749

Tell: 021-33488178

Fax: 021-33488105



TMT, TMTU, TMTW and TMT FL Orbital Motors

Technical Information

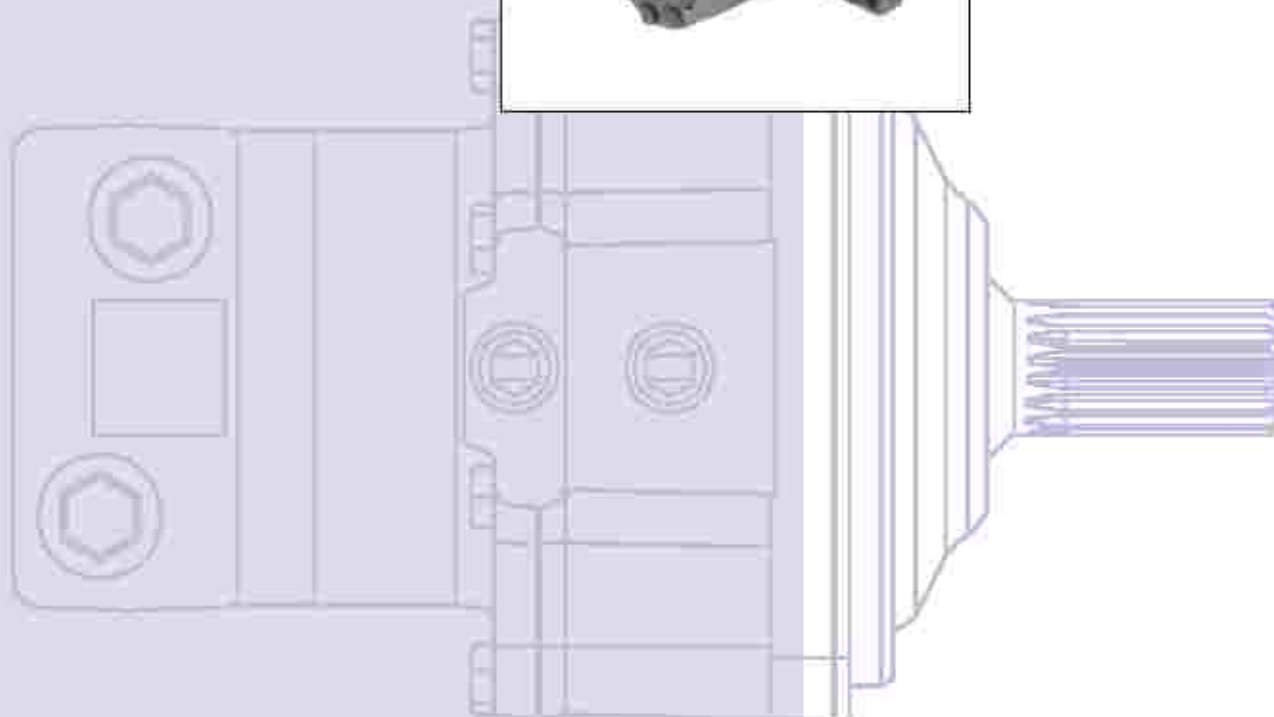



MTU, TMTW and TMT FL
Technical Information
A Wide Range of Orbital Motors

A WIDE RANGE OF
ORBITAL MOTORS



Sauer-Danfoss is a world leader within production of low speed orbital motors with high torque. We can offer more than 1600 different orbital motors, categorised in types, variants and sizes (Incl. different shaft versions).

The motors vary in size (rated displacement) from 8 cm³ [0.50 in³] to 800 cm³ [48.9 in³] per revolution.

Speeds range up to approx. 2500 min⁻¹ (rpm) for the smallest type and up to approx. 600 min⁻¹ (rpm) for the largest type.

Maximum operating torques vary from 13 N·m [115 lbf·in] to 2700 N·m [24,000 lbf·in] (peak) and maximum outputs are from 2,0 kW [2,7 hp] to 70 kW [95 hp].

Characteristic features:

- Smooth running over the entire speed range
- Constant operating torque over a wide speed range
- High starting torque
- High return pressure without the use of drain line (High pressure shaft seal)
- High efficiency
- Long life under extreme operating conditions
- Robust and compact design
- High radial and axial bearing capacity
- For applications in both open and closed loop hydraulic systems
- Suitable for a wide variety of hydraulics fluids

© 2004 Sauer-Danfoss. All rights reserved. Printed in Europe
Sauer-Danfoss accepts no responsibility for possible errors in catalogs, brochures and other printed material. Sauer-Danfoss reserves the right to alter its products without prior notice. This also applies to products already ordered provided that such alterations aren't in conflict with agreed specifications. All trademarks in this material are properties of their respective owners. Sauer-Danfoss and the Sauer-Danfoss logotype are trademarks of the Sauer-Danfoss Group.

Foot page: F 300 38a, F 300 340, F 300 261, F 300 382, F 300 731, ... drawing: 151-1944



MT, TMTU, TMTW and TMT FL Technical Information A Wide Range of Orbital Motors

A WIDE RANGE OF ORBITAL MOTORS (CONTINUED)

The programme is characterised by technical features appealing to a large number of applications and a part of the programme is characterised by motors that can be adapted to a given application. Adaptions comprise the following variants among others:

- Motors with corrosion resistant parts
- Wheel motors with recessed mounting flange
- OMP, OMR- motors with needle bearing
- OMR motor in low leakage version
- OMR motors in a super low leakage version
- Short motors without bearings
- Ultra short motors
- Motors with integrated positive holding brake
- Motors with integrated negative holding brake
- Motors with integrated flushing valve
- Motors with speed sensor
- Motors with tacho connection
- All motors are available with black finish paint

Planetary gears

Sauer-Danfoss complements the motor range with a complete programme of planetary gears adapted to suit. The combination of motors and gears makes it possible to obtain smooth running at fractional speeds and with torques up to 650 000 N·m [5 800 000 lbf·in].

The Sauer-Danfoss orbital motors are used in the following application areas:

- Construction equipment
- Agricultural equipment
- Material handling & Lifting equipment
- Forestry equipment
- Lawn and turf equipment
- Special purpose
- Machine tools and stationary equipment
- Marine equipment

SURVEY OF LITERATURE WITH TECHNICAL DATA ON SAUER-DANFOSS ORBITAL MOTORS

Detailed data on all Sauer-Danfoss motors can be found in our motor catalogue, which is divided into 5 individual subcatalogues:

- General information on Sauer-Danfoss orbital motors: function, use, selection of hydraulic motor, hydraulic systems, etc.
- Technical data on small motors: OML and OMM
- Technical data on medium sized motors: OMP, OMR, OMH and OMEW
- Technical data on medium sized motors: DH and DS
- Technical data on large motors: OMS, OMT and OMV
- Technical data on large motors: TMT

A general survey brochure on Sauer-Danfoss orbital motors gives a quick motor reference based on power, torque, speed and capabilities.



DTU, TMTW and TMT FL

Technical Information

Contents

CONTENTS	Speed and torque	5
VERSIONS	Versions	6
CODE NUMBERS	Code numbers	7
TECHNICAL DATA	Technical data	8
	Technical data (e.g. speed, torque, pressure etc.)	8
	Max. permissible shaft seal pressure	9
	Pressure drop in motor, oil flow in drain line, direction of shaft rotation	10
	Permissible shaft load	11
	Function diagrams	15
	Shaft Versions	18
	Port thread versions	20
DIMENSIONS	Dimensions	21
WEIGHT	Weight	34



MT, TMTU, TMTW and TMT FL
 Technical Information
 Data Survey

SPEED AND TORQUE

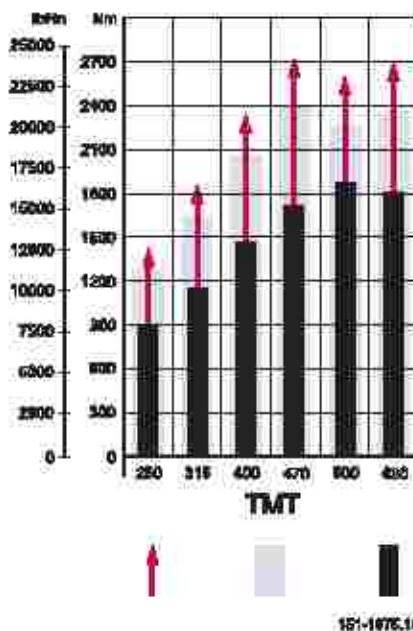
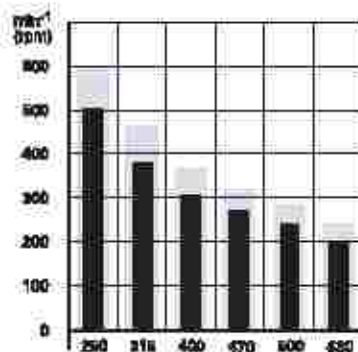

Peak values Intermittent values Continuous values

The bar diagrams above are useful for a quick selection of relevant motor size for the application. The final motor size can be determined by using the function diagram for each motor size.

- *TMT can be found* on pages 15 - 17.

The function diagrams are based on actual tests on a representative number of motors from our production. The diagrams apply to a return pressure between 5 and 10 bar [75 and 150 psi] when using mineral based hydraulic oil with a viscosity of 35 mm²/s [165 SUS] and a temperature of 50°C [120°F]. For further explanation concerning how to read and use the function diagrams, please consult the paragraph "Selection of motor size" in the technical information "General" DHMH.PK.100.G2.02: 520L0232.



VERSIONS

Mounting flange	Spigot diameter	Bolt circle diameter (BC)	Shaft	Port size	European version	US version	Side port version	Standard shaft seal	Drain connection	Check valve	Main type designation
4-Bolt	Ø 160 mm	Ø 200 mm	Cyl 40 mm	G 3/4	m		m	m	yes	No	TMT
	Ø 125 mm	Ø 160 mm	Cyl 40 mm	G 3/4	m		m	m	Yes	No	TMT
	Ø 5 in	Ø 6.37 in	Cyl 1.5 in	1 1/8 - 12 UN		m	m	m	Yes	No	TMT
	Ø 160 mm	Ø 200 mm	Splined 1.5 in	G 3/4	m		m	m	Yes	No	TMT
	Ø 125 mm	Ø 160 mm	Splined 1.5 in	G 3/4	m		m	m	yes	No	TMT
	Ø 5 in	Ø 6.37 in	Splined 1.5 in	1 1/8 - 12 UN		m	m	m	Yes	No	TMT
	Ø 160 mm	Ø 200 mm	Tap 45 mm	G 3/4	m		m	m	Yes	No	TMT
	Ø 125 mm	Ø 160 mm	Tap 45 mm	G 3/4	m		m	m	yes	No	TMT
	Ø 5 in	Ø 6.37 in	Tap 1 1/8 in	1 1/8 - 12 UN		m	m	m	Yes	No	TMT
	-	-	-	G 3/4	m		m		Yes	No	TMT U
-	-	-	1 1/8 - 12 UN		m	m		Yes	No	TMT U	
4-Bolt	Ø 125 mm	Ø 160 mm	Splined 1.5 in	G 3/4	m		m	m	Yes	No	TMT FL
	Ø 5 in	Ø 6.37 in	Splined 1.5 in	1 1/8 - 12 UN		m	m	m	Yes	No	TMT FL
	Ø 180 mm	Ø 224 mm	Splined 1.5 in	G 3/4	m		m	m	Yes	No	TMT FL
	Ø 180 mm	Ø 224 mm	Tap 45 mm	G 3/4	m		m	m	Yes	No	TMT FL
	Ø 7.08 in	Ø 8.82 in	Splined 1.5 in	1 1/8 - 12 UN		m	m	m	Yes	No	TMT FL
Wheel	Ø 160 mm	Ø 210 mm	Thread hole fl.	G 3/4	m		m	m		No	TMTW
	Ø 160 mm	Ø 210 mm	Thread hole fl.	1 1/8 - 12 UN		m	m	m	Yes	No	TMTW

Function diagram - see page →

Features available (options)

Flushing valve with different flushing flow

Brake with higher holding torque capacity

Painted



MT, TMTU, TMTW and TMT FL

Technical Information

Code Numbers

CODE NUMBERS

CODE NUMBERS	DISPLACEMENT [cm ³]						Technical data - Page	Dimensions - Page
	250	315	400	470	500	630		
151Z	3010	3011	3012	3013	3014	3015	8	23
151Z	3016	3017	3018	-	-	-	8	24
151Z	3060	3061	3062	3063	3064	3065	8	25
151Z	3020	3021	3022	3023	3024	3025	8	23
151Z	3026	3027	3028	-	-	-	8	24
151Z	3070	3071	3072	3073	3074	3075	8	25
151Z	3030	3031	3032	3033	3034	3035	8	23
151Z	3036	3037	3038	-	-	-	8	24
151Z	3080	3081	3082	3083	3084	3085	8	25
151Z	3000	3001	3002	3003	3004	3005	8	26
151Z	3100	3101	3102	3103	3104	3105	8	27
151Z	3040	3041	3042	3043	3044	3045	8	28
151Z	3050	3051	3052	3053	3054	3055	8	28
151Z	3090	3091	3092	3093	3094	3095	8	29
151Z	3110	3111	3112	3113	3114	3115	8	31
151Z	3120	3121	3122	3123	3124	3125	8	31
151Z	3130	3131	3132	3133	3134	3135	8	30
151Z	3229	3230	3231	3232	3233	3234	8	32
151Z	3273	3274	3275	3276	3277	3278	8	33
→	15	15	16	16	17	17		

Ordering

Add the four digit prefix "151Z" to the four digit numbers from the chart for complete code number.

Example:

151Z3012 for an TMT 400 with mounting flange Ø 160 mm, cyl. 40 mm shaft, port size G 3/4" and side port version.

Orders will not be accepted without the four digit prefix.



TECHNICAL DATA FOR TMT, TMTU, TMTW AND TMT FL

Type	Motor size		TMT 250	TMT 315	TMT 400	TMT 470	TMT 500	TMT 630
Geometric displacement	cm ³ [in ³]		251.8 [15.37]	326.3 [19.91]	410.9 [25.07]	477.3 [29.13]	494.8 [30.19]	629.1 [38.39]
Max. speed	min ⁻¹ [rpm]	cont.	300	380	305	270	250	200
		int. ¹⁾	600	460	360	320	300	240
Max. torque	N·m [lbf·in]	cont.	940 [8320]	1230 [10890]	1520 [13450]	1760 [15580]	1770 [15670]	1830 [16200]
		int. ¹⁾	1290 [11420]	1660 [14690]	2120 [18760]	2420 [21420]	2240 [19825]	2290 [20270]
		peak ²⁾	1440 [12.745]	1865 [16.500]	2355 [20.845]	2735 [24.210]	2390 [21.150]	2740 [24250]
Max. output	kW [hp]	cont.	35 [47]	35 [47]	37 [50]	37 [50]	35 [47]	27 [36]
		int. ¹⁾	47 [63]	47 [63]	51 [68]	49 [66]	42 [56]	33 [44]
Max. pressure drop	bar [psi]	cont.	250 [3630]	250 [3630]	250 [3630]	250 [3630]	250 [3630]	200 [2900]
		int. ¹⁾	350 [5080]	350 [5080]	350 [5080]	350 [5080]	325 [4710]	250 [3630]
		peak ²⁾	400 [5800]	400 [5800]	400 [5800]	400 [5800]	375 [5440]	300 [4350]
Max. oil flow	l/min [USgal/min]	cont.	125 [33]	125 [33]	125 [33]	125 [33]	125 [33]	125 [33]
		int. ¹⁾	150 [39.6]	150 [39.6]	150 [39.6]	150 [39.6]	150 [39.6]	150 [39.6]
Max. starting pressure with unloaded shaft	bar [psi]		6 [90]	6 [90]	6 [90]	6 [90]	6 [90]	6 [90]
Min. starting torque	at max. press. drop N·m [lbf·in]	cont.	780 [6690]	1060 [9380]	1360 [12040]	1500 [13280]	1530 [13540]	1600 [14160]
		int. ¹⁾	1080 [9580]	1520 [13450]	1930 [17080]	2050 [18140]	1820 [16100]	1990 [17500]
		peak ²⁾						

Type		Max. inlet pressure	Max. return pressure with drain line
TMT 250 - 630	bar (psi)	cont.	270 [3915]
	bar (psi)	int. ¹⁾	370 [5365]
	bar (psi)	peak ²⁾	420 [6090]

For max. permissible combination of flow and pressure, see function diagram for actual motor

¹⁾ Intermittent operation; the permissible values may occur for max. 10% of every minute

²⁾ Peak load; the permissible value may occur for max. 1% of every minute



MT, TMTU, TMTW and TMT FL

Technical Information

Technical Data

TECHNICAL DATA FOR
BRAKE MOTOR TMT FL

Technical data for brake motor TMT FL		
Holding torque ¹⁾	N·m [lbf·in]	2000 [17 700]
Min. release pressure ²⁾	bar [psi]	13 [190]
Max. release pressure cont.	bar [psi]	25 [365]
Max. release pressure peak	bar [psi]	40 [580]

¹⁾ Brakes with higher holding torque available, please contact Sauer-Danfoss.

²⁾ The release pressure is the difference between the pressure in the brake line and the pressure in the drain line.

Bleed off from brake release chamber to drain line is 0.65 l/min [0.172 US gal/min] at 13 bar [188 psi] release pressure.

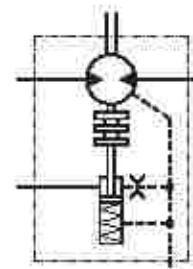

101-9091.10

MAX. PERMISSIBLE
SHAFT SEAL PRESSURE

TMT with standard shaft seal and drain connection
The pressure on shaft seal equals the pressure in the drain line.

TMT FL with standard shaft seal.
The pressure on shaft seal equals the pressure in release port.

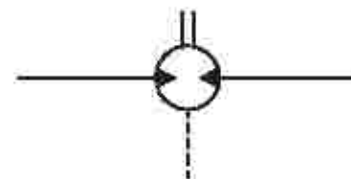

101-1003.10

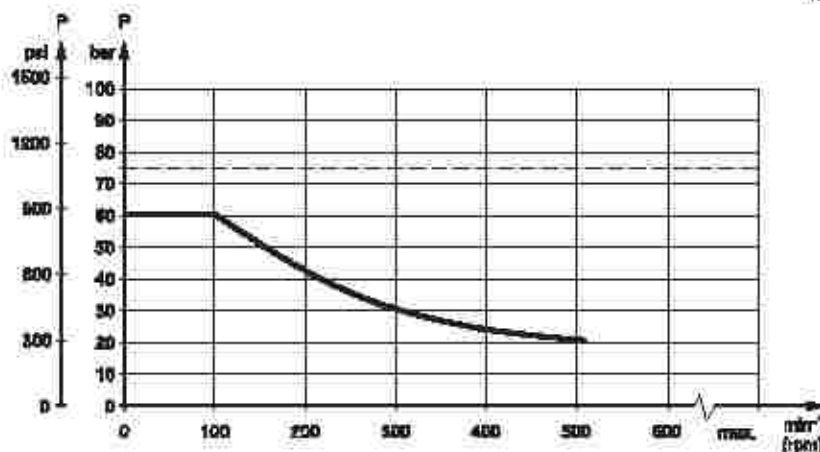

101-1073.10

--- Intermittent operation: The permissible values may occur for max. 10% of every minute.

— Continuous operation

Warning

Drain line should always be used.



PRESSURE DROP IN MOTOR

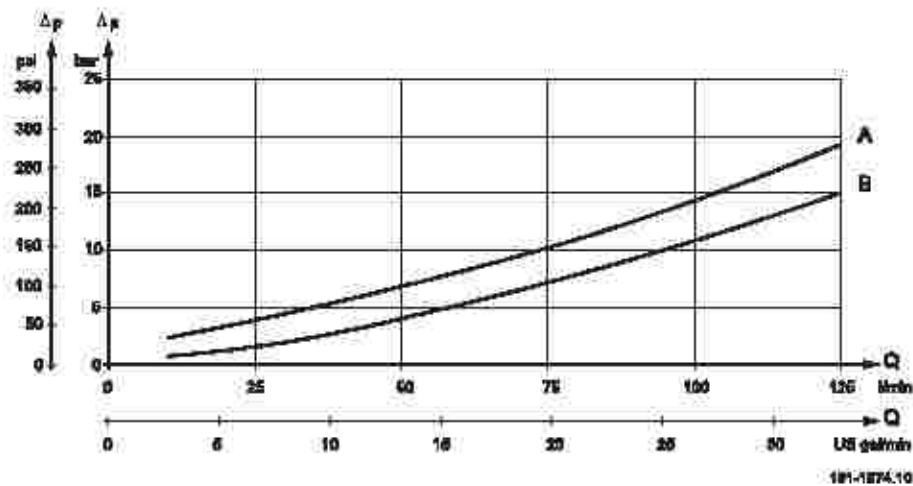

The curve applies to an unloaded motor shaft and an oil viscosity of 35 mm²/s [165 SUS].
 A: TMT 250, 315 B: TMT 400, 470, 500 and 630

OIL FLOW IN DRAIN LINE

The table below shows the max. oil flow in the drain line at a return pressure less than 5-10 bar [75-150 psi].

Pressure drop bar [psi]	Viscosity	
	mm ² /s [SUS]	Oil flow in drain line l/min [US gal/min]
300 [2000]	20 [100]	2.5 [0.66]
	35 [165]	1.5 [0.4]
275 [3090]	20 [100]	4.0 [1.1]
	35 [165]	2.5 [0.66]

DIRECTION OF SHAFT ROTATION

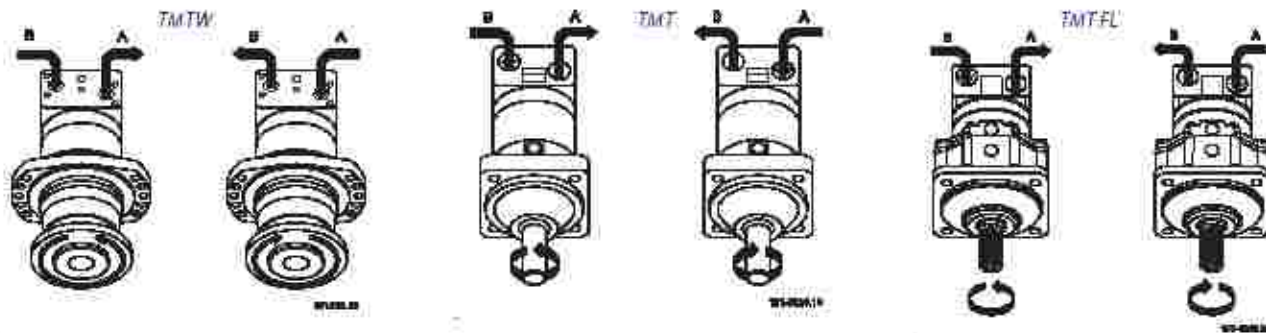



**PERMISSIBLE SHAFT
LOAD FOR TMT AND
TMT FL**

Spigot diameter \varnothing 160 mm [6.3 in] TMT and \varnothing 180 mm [7.1 in] TMT FL

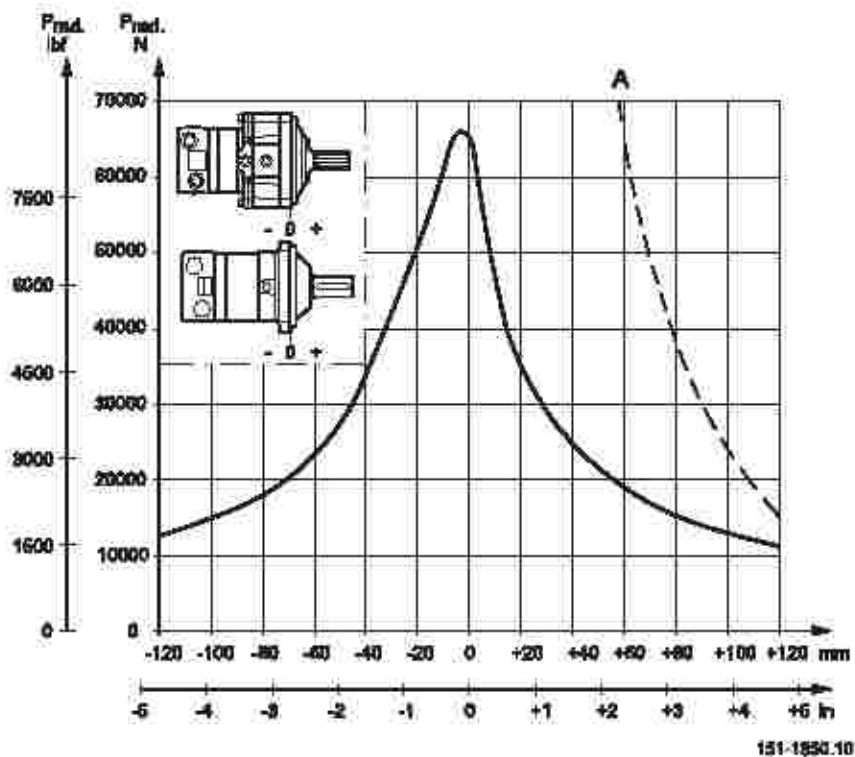

Permissible radial shaft load

The output shaft runs in tapered roller bearings that permit high axial and radial forces.

The permissible radial load on the shaft is shown for an axial load of 0 N as a function of the distance from the mounting flange to the point of load application.

The curve is based on B_{10} Bearing life (2000 hours or 12 000 000 shaft revolutions at 100 min⁻¹) at rated output torque, when mineral-based hydraulic oil with a sufficient content of anti-wear additives, is used.

The dash curve **A** shows max. radial shaft load. Any shaft load exceeding the values shown in the curve will involve a risk of breakage.

**PERMISSIBLE SHAFT
LOAD FOR TMT AND
TMT FL
(CONTINUED)**

Spigot diameter \varnothing 125 mm [4.92 in] TMT and TMT FL

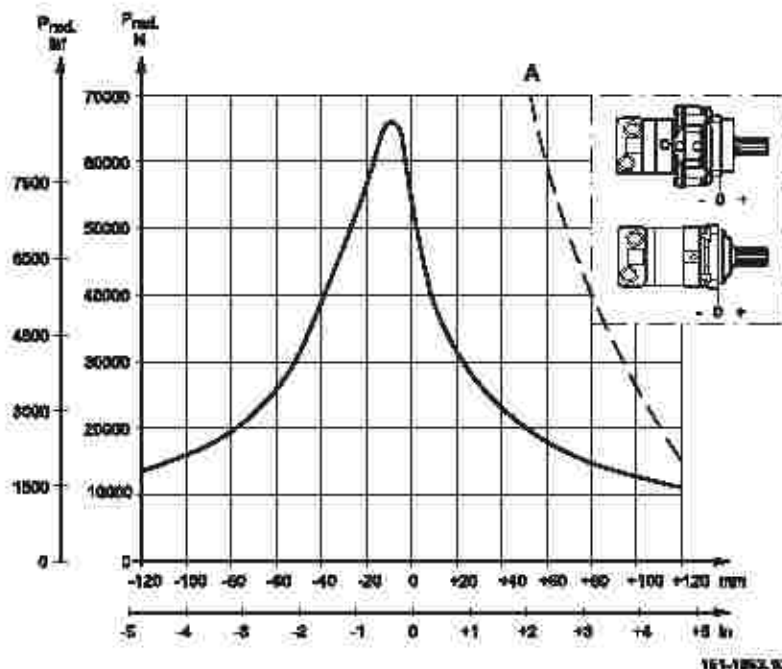

Permissible radial shaft load

The output shaft runs in tapered roller bearings that permit high axial and radial forces.

The permissible radial load on the shaft is shown for an axial load of 0 N as a function of the distance from the mounting flange to the point of load application.

The curve is based on B_{10} Bearing life (2000 hours or 12 000 000 shaft revolutions at 100 min⁻¹) at rated output torque, when mineral-based hydraulic oil with a sufficient content of anti-wear additives is used.

The dash curve **A** shows max. radial shaft load. Any shaft load exceeding the values shown in the curve will involve a risk of breakage.



MT, TMTU, TMTW and TMT FL

Technical Information

Technical Data

**PERMISSIBLE SHAFT
LOAD FOR TMT AND
TMT FL
(CONTINUED)**

Spigot diameter \varnothing 12.7 mm [5.0 in] TMT and TMT FL

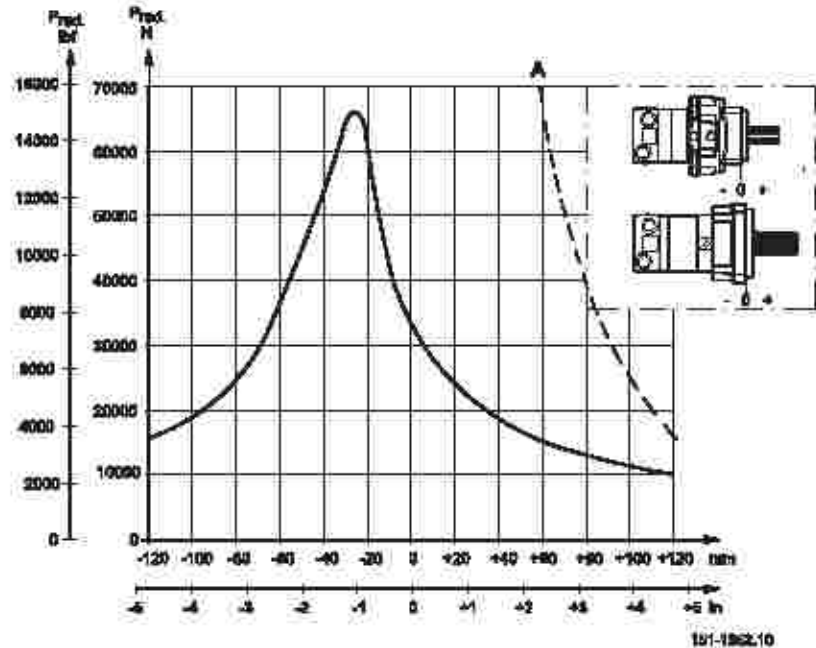

Permissible radial shaft load

The output shaft runs in tapered roller bearings that permit high axial and radial forces.

The permissible radial load on the shaft is shown for an axial load of 0 N as a function of the distance from the mounting flange to the point of load application.

The curve is based on B_{10} Bearing life (2000 hours or 12 000 000 shaft revolutions at 100 min⁻¹) at rated output torque, when mineral-based hydraulic oil with a sufficient content of anti-wear additives, is used.

The dash curve **A** shows max. radial shaft load. Any shaft load exceeding the values shown in the curve will involve a risk of breakage.

PERMISSIBLE SHAFT LOAD FOR TMTW

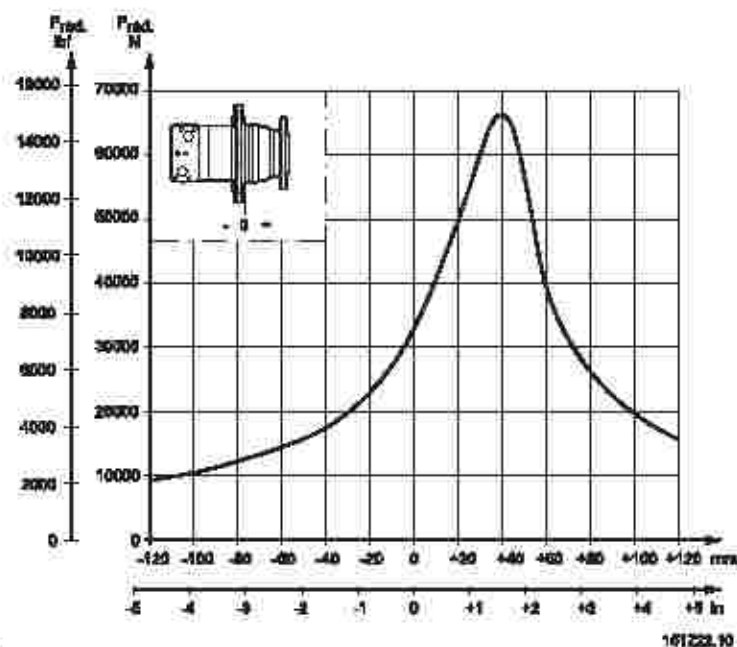

Permissible radial shaft load

The output shaft runs in tapered roller bearings that permit high axial and radial forces.

The permissible radial load on the shaft is shown for an axial load of 0 N as a function of the distance from the mounting flange to the point of load application.

The curve is based on B_{10} Bearing life (2000 hours or 12 000 000 shaft revolutions at 100 min⁻¹) at rated output torque, when mineral-based hydraulic oil with a sufficient content of anti-wear additives, is used.



MT, TMTU, TMTW and TMT FL

Technical Information

Function diagrams

FUNCTION DIAGRAMS

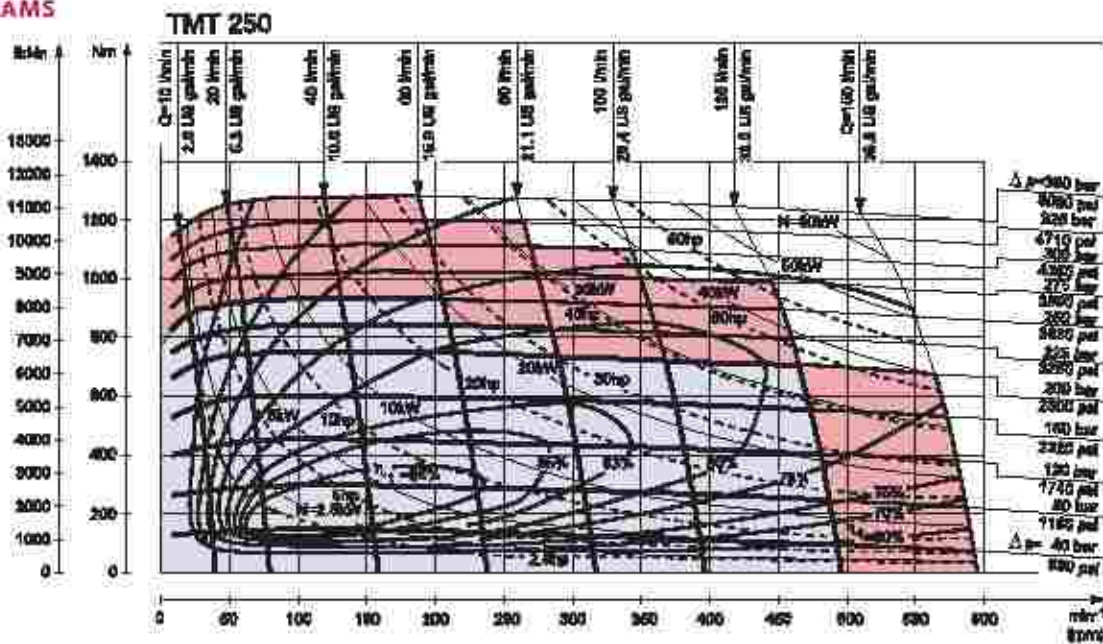

101-1000.10

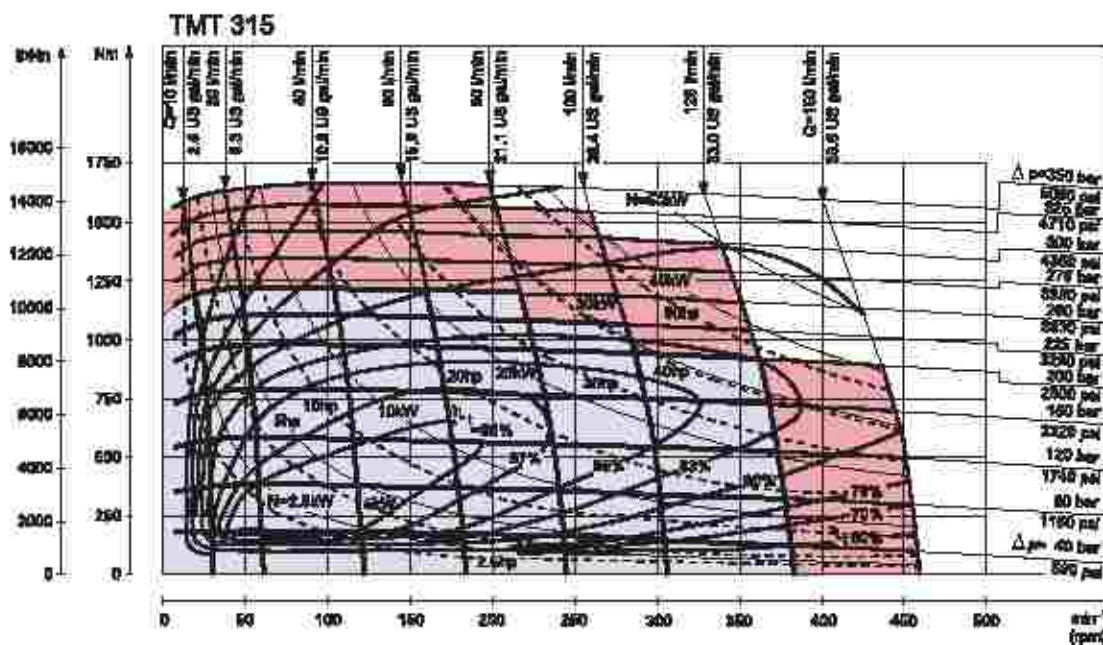

101-1300.10

Explanation of function diagram use, *basis and conditions* can be found on page 5.

- Continuous range
- Intermittent range (max. 10% operation every minute)

Intermittent pressure drop and oil flow must not occur simultaneously.



ATU, TMTW and TMT FL

Technical Information

Function diagrams

FUNCTION DIAGRAMS
(CONTINUED)

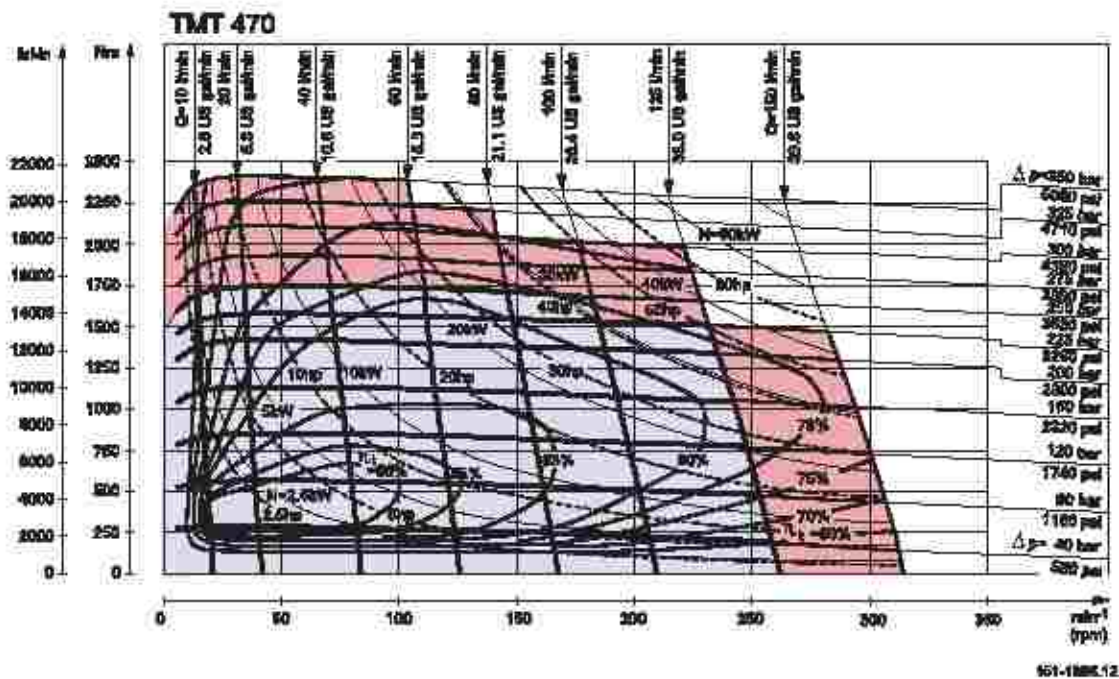
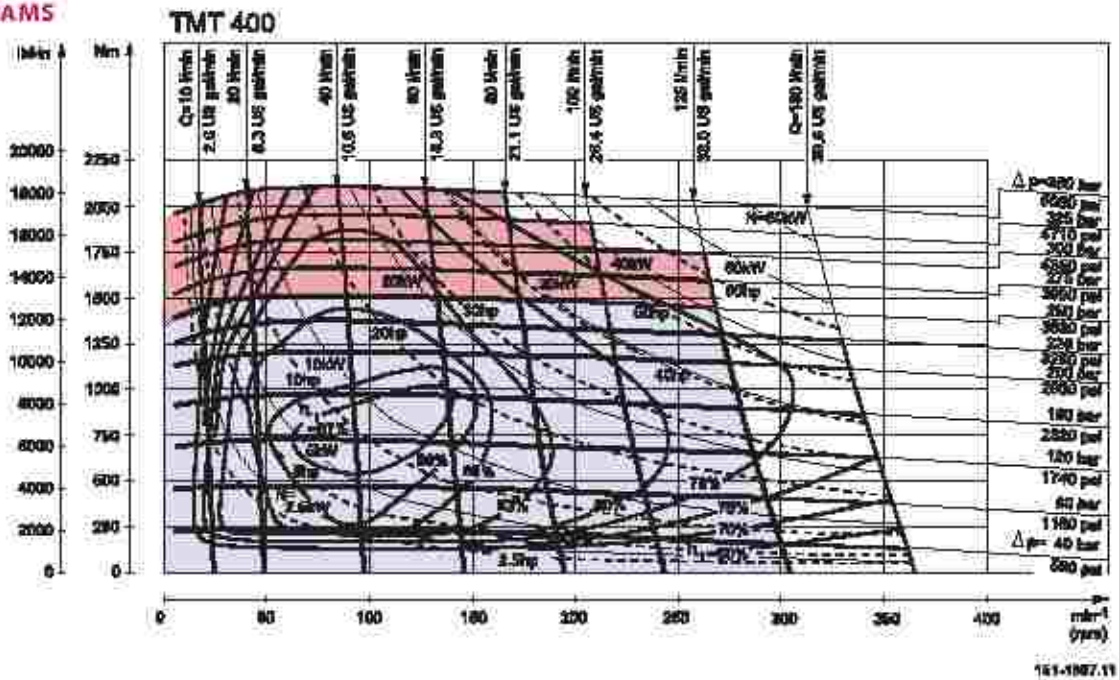

Explanation of function diagram use, *basis and conditions* can be found on page 5.

- Continuous range
- Intermittent range (max. 10% operation every minute)

Intermittent pressure drop and oil flow must not occur simultaneously.



FUNCTION DIAGRAMS
(CONTINUED)

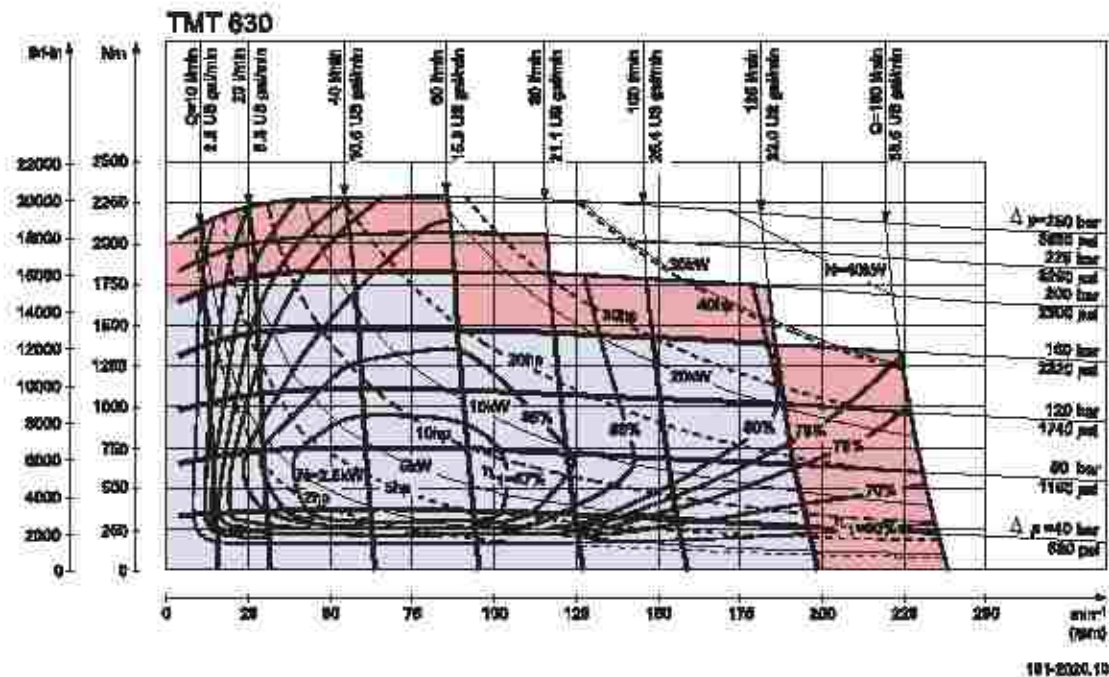
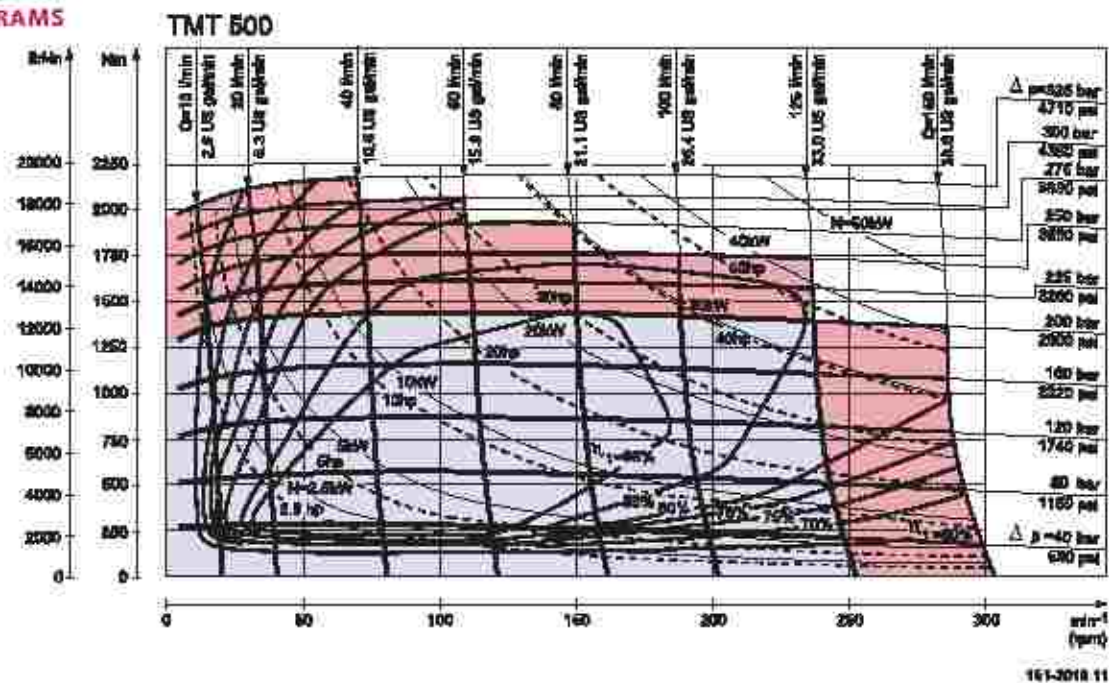

Explanation of function diagram use, *basis and conditions* can be found on page 5.

- Continuous range
- Intermittent range (max. 10% operation every minute)

Intermittent pressure drop and oil flow must not occur simultaneously.



MTU, TMTW and TMT FL
Technical Information
Shaft Versions, European versions

SHAFT VERSIONS

- A: Cylindrical shaft $\varnothing 40$ mm
F: Parallel key
A12 x 8 x 70
DIN 6885

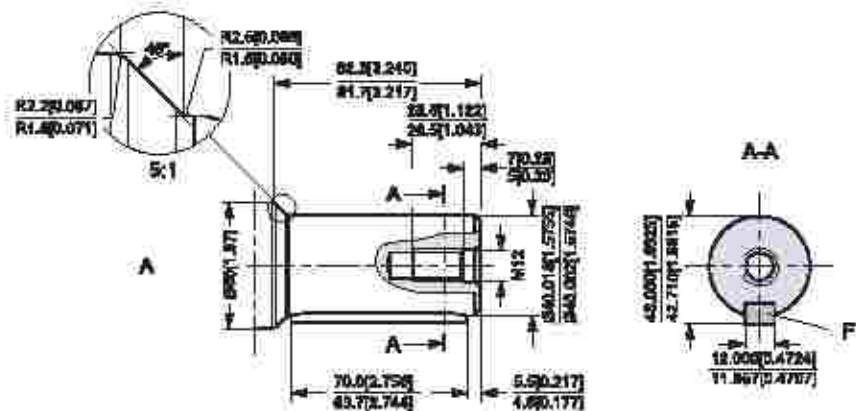

- B: Involute splined shaft ANS
B92.1 - 1970 standard
Flat root side fit
Pitch 12/24
Teeth 17
Major diam. 1.50 inch
Pressure angle 30°

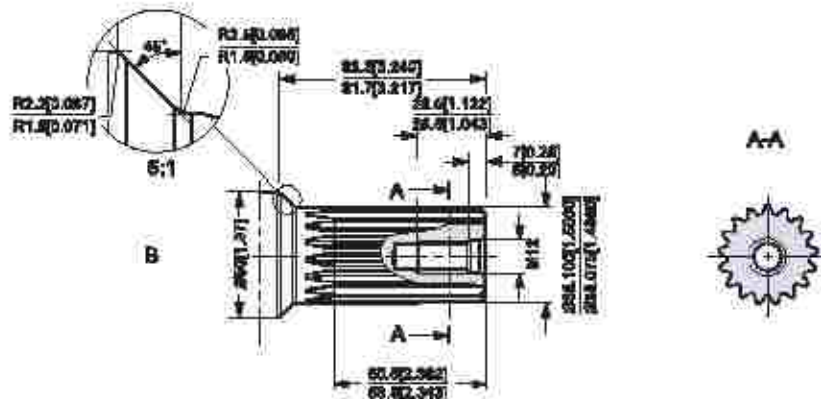

- C: Tapered shaft $\varnothing 45$ mm
(ISO/R775)
E: DIN 937
Across flats: 46
Tightening torque:
500 ± 30 N·m [4425 ± 265 lbf·in]
D: Taper 1 : 10
G: Parallel key
B12 x 8 x 28

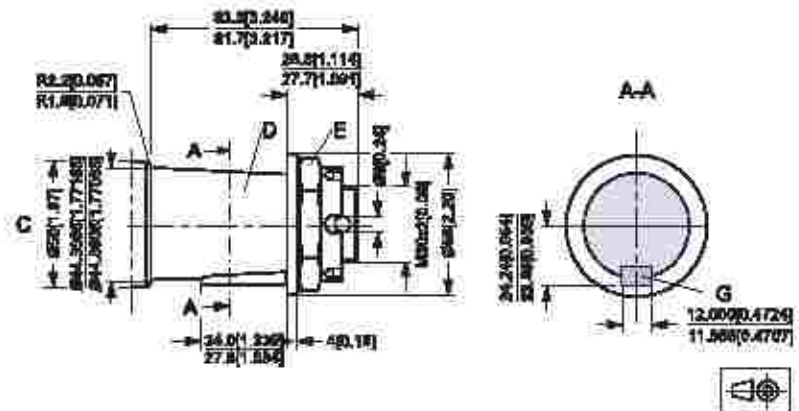

151-1800.10



MT, TMTU, TMTW and TMT FL
 Technical Information
 Shaft Versions, US versions

SHAFT VERSIONS

- D: Cylindrical shaft
 Ø 1 1/2 inch
- E: Parallel key
 3/8 x 3/8 x 2 1/4 inch
 B.S. 46

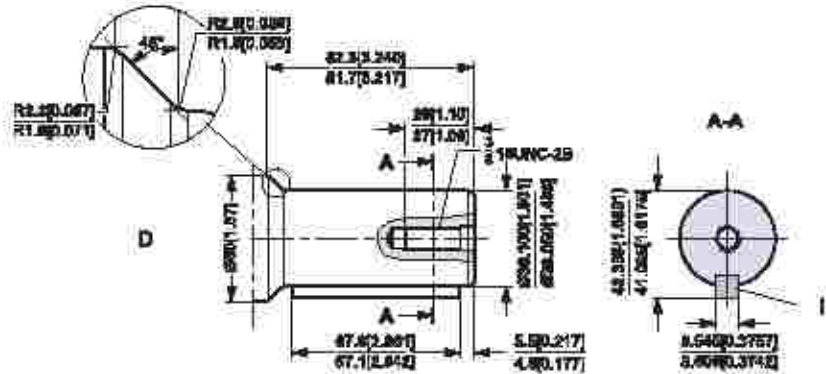

- E: Involute splined shaft ANS
 B92.1 - 1970 standard
 Flat root side fit
 Pitch 12/24
 Teeth 17
 Major diam. 1.50 inch
 Pressure angle 30°

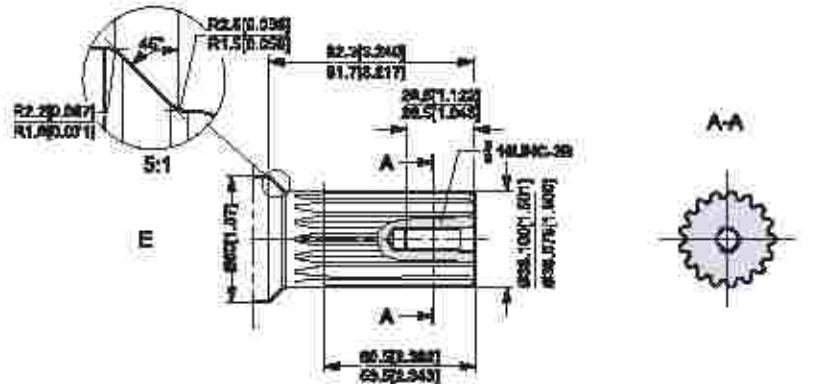

- F: Tapered shaft 1 3/4 in
- G: Cone 1 : 8
 SAE J501
- H: 1 1/4 - 18 UNEF
 across flats: 2 2/16 inch
 Tightening torque:
 4425 ± 265 lbf-in [500 ± 30 N·m]
- J: Parallel key
 7/16 x 7/16 x 1 1/4 inch
 B.S. 46

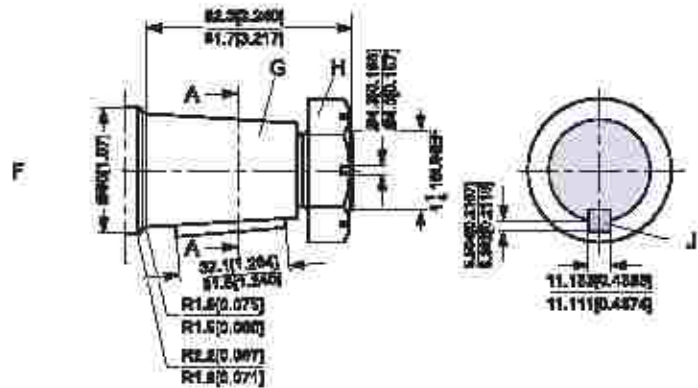

191-1821-02



MTU, TMTW and TMT FL
Technical Information
Technical Data

PORT THREAD VERSIONS

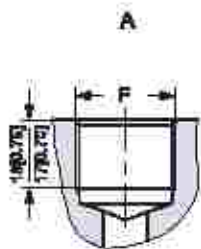

A: G Main port
E: ISO 228/1 – G 3/4

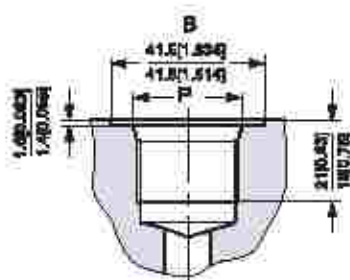

B: UNF Main port
P: 1 1/8 – 12 UN

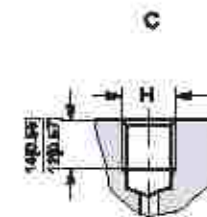

C: G Drain/release port
H: ISO 228/1 – G 1/4

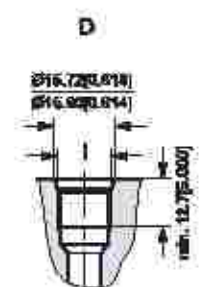

D: UNF Drain port
I: 7/8 – 18 UNF
O-ring boss port

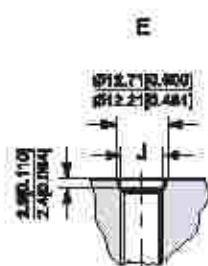

E: UNF Release port
J: 7/8 – 20 UNF
O-ring boss port

125-1048-10



MT, TMTU, TMTW and TMT FL

Technical Information

Dimensions – Attached Component

DIMENSIONS OF THE ATTACHED COMPONENT FOR TMT U (BEARING LESS)

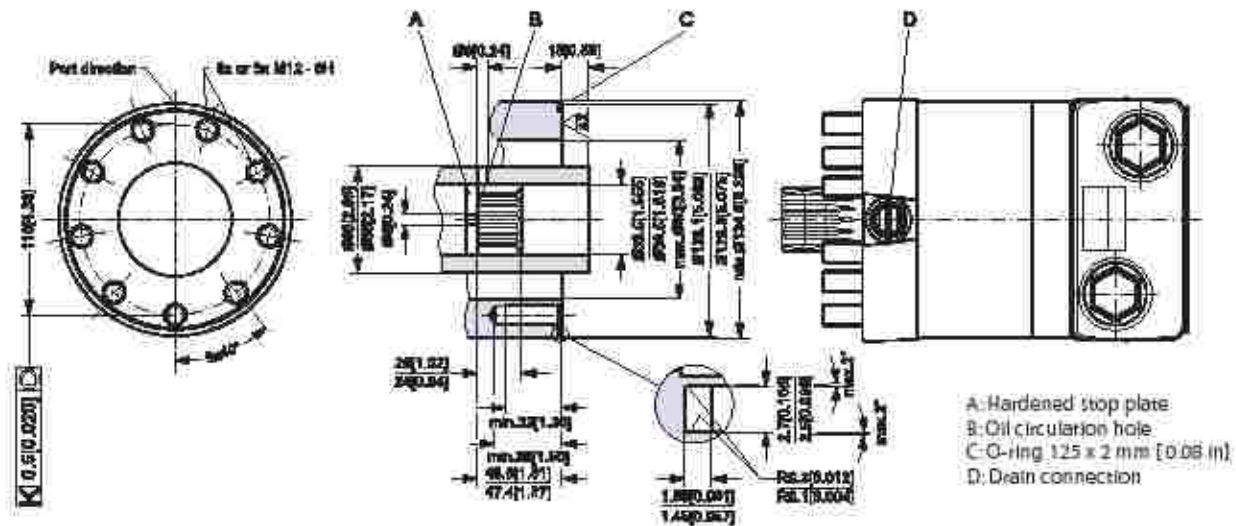

161-1626.14

Internal spline data for the component to be attached

The attached component must have internal splines corresponding to the external splines on the motor cardan shaft, please see drawings.

Material:

Case hardening steel with a tensile strength corresponding at least to 20 MoCr4 (90 daN/mm²). See also SAE 8620 for further information on steel material.

Hardening specification:

- on the surface: HV = 750 ± 50
- 0.7 ± 0.2 mm under the surface: HV = 560

Standard ANSI B92.1 - 1970, class 5 (corrected m, x = 1; m = 2,1166)		
Flat root side fit	mm	inch
Number of teeth z	16	16
Pitch DP	12/24	12/24
Pressure angle	30°	30°
Pitch dia. D	33.8656	1.3333
Major dia. D _a	38.4 ^{+0.4} ₀	1.5118 ^{+0.0157} ₀
Form dia. (min) D _f	37.6	1.4803
Minor dia. D _i	32.15 ^{+0.04} ₀	1.2657 ^{+0.00157} ₀
Space width (circular)Lo	4.516 ± 0.037	0.1777 ± 0.0014
Tooth thickness (circular)S _a	2.170	0.0854
Fillet radius R _{mm}	0.5	0.02
Max. measurement between pins*	26.9 ^{+0.1} ₀	1.059 ^{+0.004} ₀
Pin dia. d	4.843 ± 0.001	0.1903 ± 0.00004

*Finished dimensions (when hardened)

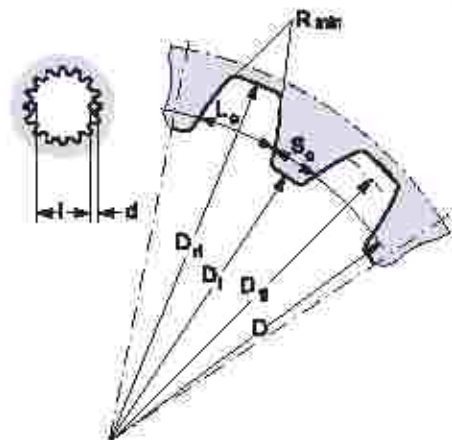

161-486.10



TMTU, TMTW and TMT FL

Technical Information

Dimensions

DRAIN CONNECTION ON TMTU OR ATTACHED COMPONENT

A drain line should always be used.

The drain line can be connected at two different points:

- at the motor drain connection
- at the drain connection of the attached component

If a drain is fitted to the attached component, it must be possible for oil to flow freely between motor and the attached component.

The drain line must be led to the tank in such a way that there is no risk of the motor and the attached component being drained of oil when at rest.

The maximum pressure in the drain line is limited by the attached component and its shaft seal.

BLANK SHAFT

A blank shaft is available for TMTU motor, please contact Sauer-Danfoss Sales Organisation.

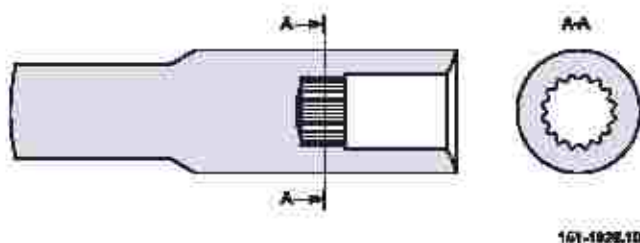

After machining the blank shaft must be hardened *according to Sauer-Danfoss specification* on page 21.



MT, TMTU, TMTW and TMT FL

Technical Information

Dimensions, European version

DIMENSIONS

4-Bolt flange-spigot diameter Ø 160 mm - BC Ø 200 mm

Type	L mm (in)	L ₁ mm (in)	L ₂ mm (in)
TMT 250	191.5 [7.54]	165 [6.50]	150.5 [5.93]
TMT 315	200.8 [7.91]	174.3 [6.86]	158.9 [6.26]
TMT 400	211.3 [8.32]	184.8 [7.28]	170.3 [6.70]
TMT 470	219.5 [8.64]	193 [7.60]	178.5 [7.03]
TMT 500	211.3 [8.32]	184.8 [7.28]	170.3 [6.70]
TMT 630	225.3 [8.87]	198.8 [7.83]	184.3 [7.26]

C: G 3/4; 17 mm [0.67 in] deep

D: Drain connection

G 1/4; 12 mm [0.47 in] deep

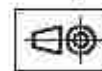
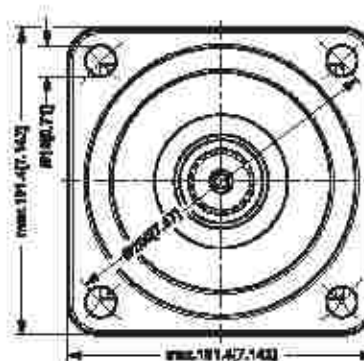
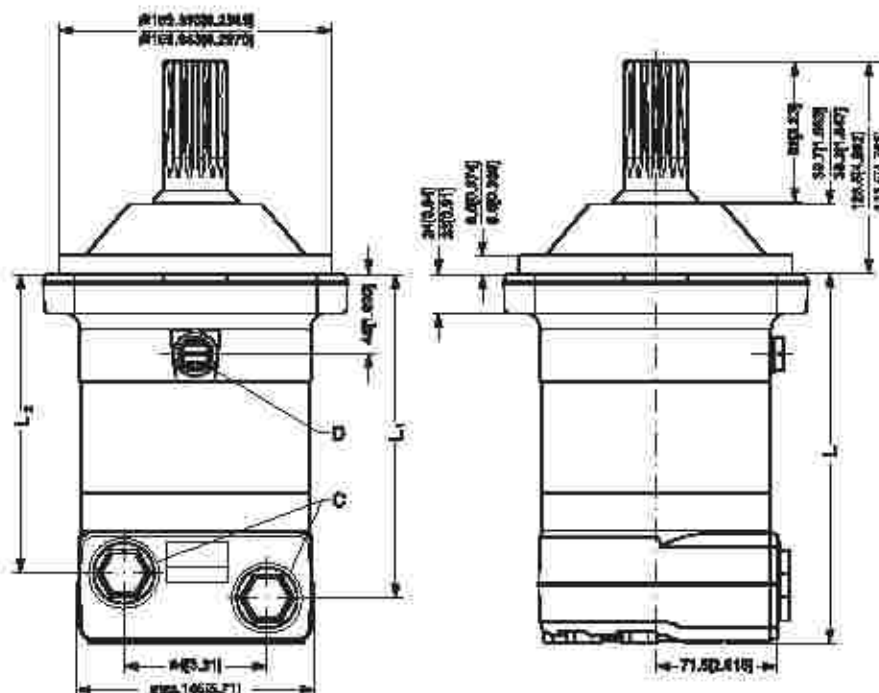

161-1806-02



TU, TMTW and TMT FL
Technical Information
Dimensions, European version

DIMENSIONS

4-Bolt flange-spigot diameter Ø 125 mm - BC Ø 160 mm

Type	L mm (in)	L ₁ mm (in)	L ₂ mm (in)
TMT 250	200 [7.87]	173.5 [6.83]	159 [6.26]
TMT 315	209.3 [8.24]	182.8 [7.20]	168.3 [6.63]
TMT400	219.8 [8.65]	193.3 [7.61]	178.8 [7.04]
TMT 470	228 [8.98]	201.5 [7.93]	187 [7.36]
TMT 500	219.8 [8.65]	193.3 [7.61]	178.8 [7.04]
TMT 630	233.8 [9.20]	207.3 [8.16]	192.8 [7.59]

C: G^{3/4}: 17 mm [0.67] deep

D: Drain connection

G^{3/4}: 12 mm Ø 47 in deep

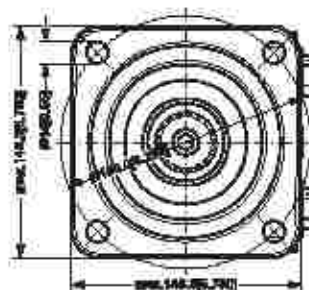
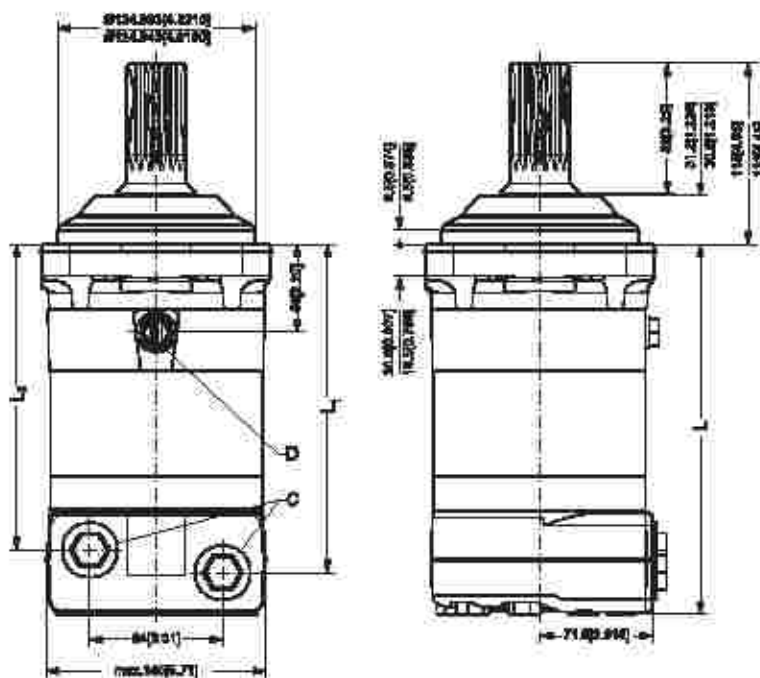

991-0023.02



MT, TMTU, TMTW and TMT FL
 Technical Information
 Dimensions, US version

DIMENSIONS

4-Bolt flange-spigot diameter Ø 5 in, SAE C mounting flange - BC Ø 6.37 in

Type	L ₁ mm (in)	L ₂ mm (in)	L ₃ mm (in)
TMT 250	218.7 [8.61]	192.4 [7.57]	177.9 [7.00]
TMT 315	227.9 [8.97]	201.7 [7.94]	187.2 [7.37]
TMT 400	238.4 [9.39]	212.2 [8.35]	197.7 [7.78]
TMT 470	246.7 [9.71]	220.4 [8.68]	205.9 [8.11]
TMT 500	238.4 [9.39]	212.2 [8.35]	197.7 [7.78]
TMT 630	252.4 [9.94]	226.2 [8.91]	211.7 [8.33]

- C: 1¹/₂" - 12 UN O-ring boss port;
19 mm [0.75 in] deep
- D: Drain connection 3/8" - 18 UNF
O-ring boss port; 12.7 mm [0.5 in] deep

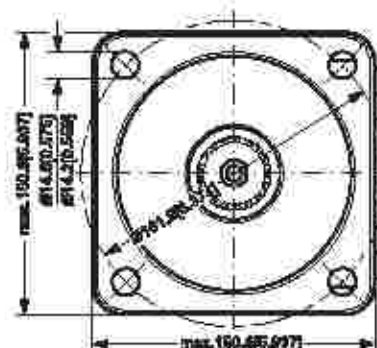
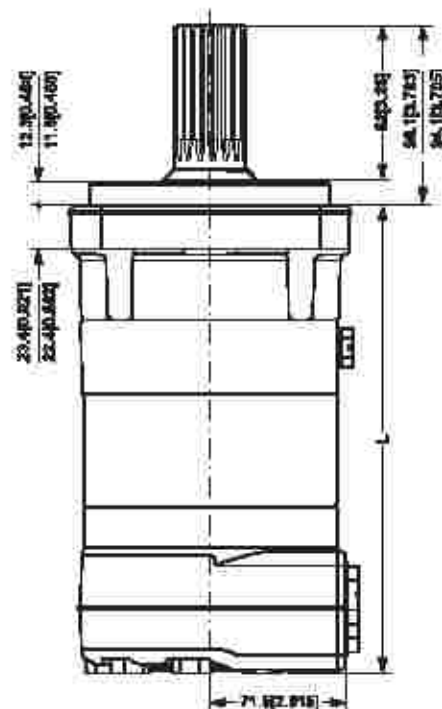
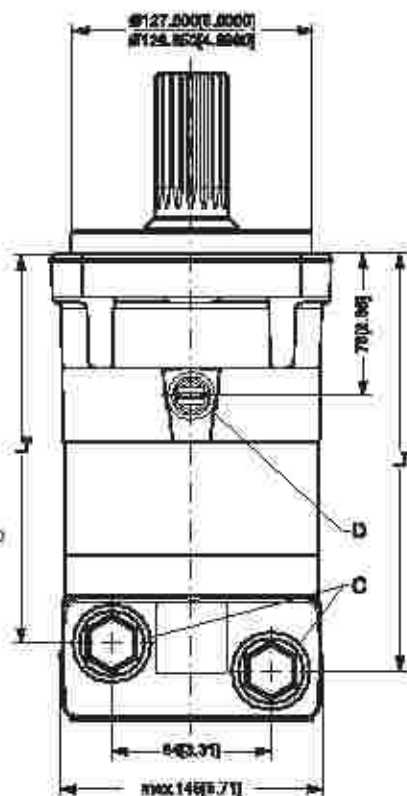

101-1002.18



TMTU, TMTW and TMT FL
 Technical Information
 Dimensions, European version

DIMENSIONS

Bearing less

Type	L mm (in)	L ₁ mm (in)	L ₂ mm (in)
TMTU 250	158.5 [6.24]	131 [5.16]	117.3 [4.63]
TMTU 315	168.8 [6.65]	141.3 [5.56]	126.8 [4.99]
TMTU 400	178.3 [7.02]	151.8 [5.98]	137.3 [5.41]
TMTU 470	186.5 [7.32]	160 [6.30]	145.3 [5.73]
TMTU 500	178.3 [7.02]	151.8 [5.98]	137.3 [5.41]
TMTU 630	192.3 [7.57]	165.8 [6.53]	151.3 [5.96]

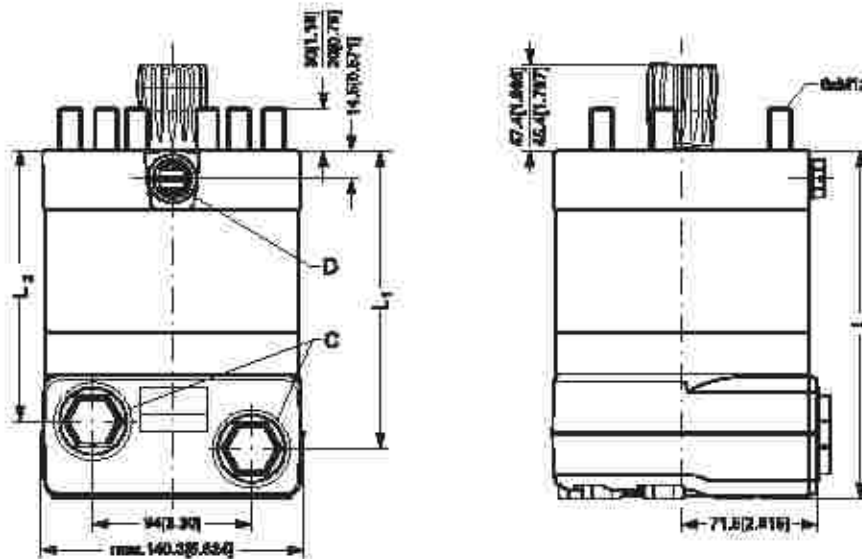

C: G^{3/4}: 17 mm [0.67 in] deep

D: Drain connection

G^{3/4}: 1

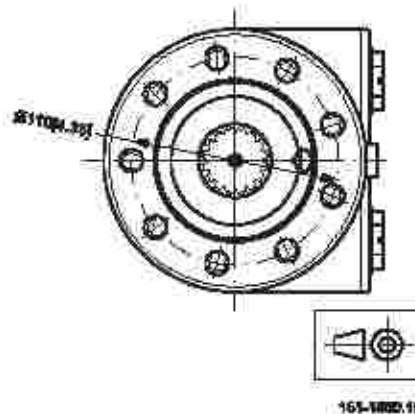



MT, TMTU, TMTW and TMT FL

Technical Information
Dimensions, US version

DIMENSIONS

Bearing less

Type	L mm (in)	L ₁ mm (in)	L ₂ mm (in)
TMTU 250	158.5 [6.24]	131 [5.16]	117.5 [4.63]
TMTU 315	168.8 [6.65]	141.3 [5.56]	126.8 [4.99]
TMTU 400	178.3 [7.02]	151.8 [5.98]	137.3 [5.41]
TMTU 470	186.5 [7.32]	160 [6.26]	145.5 [5.73]
TMTU 500	178.3 [7.02]	151.8 [5.98]	137.3 [5.41]
TMTU 630	192.3 [7.57]	165.8 [6.53]	151.3 [5.96]

C: 1 1/16-12 UN O-ring boss port;
19 mm [0.75 in] deep

D: Drain connection 1/16-38 UNF
O-ring boss port;
12.7 mm [0.5 in] deep

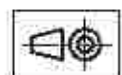
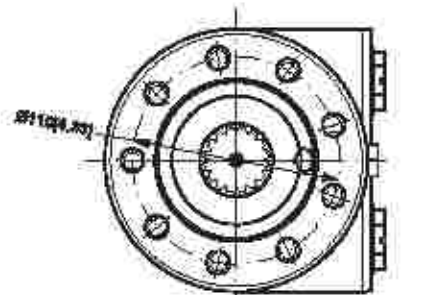
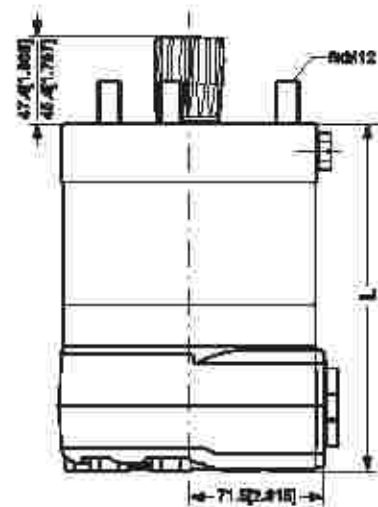
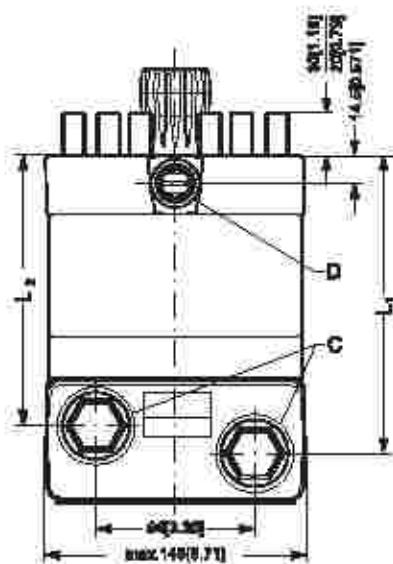

101-1000.11



TU, TMTW and TMT FL
Technical Information
Dimensions, European version

DIMENSIONS

4-Bolt flange-spigot diameter \varnothing 125 mm - BC \varnothing 160 mm

Type	L mm (in)	L ₁ mm (in)	L ₂ mm (in)
TMT 250 FL	240.1 [9.45]	233.6 [9.41]	199.1 [7.84]
TMT 315 FL	249.4 [9.82]	222.9 [8.78]	208.4 [8.20]
TMT 400 FL	259.9 [10.23]	233.4 [9.19]	218.9 [8.62]
TMT 470 FL	268.2 [10.56]	241.7 [9.52]	227.2 [8.94]
TMT 500 FL	259.9 [10.23]	233.4 [9.19]	218.9 [8.62]
TMT 630 FL	273.9 [10.78]	247.4 [9.74]	232.9 [9.17]

- C: G^{3/4}; 17 mm [0.67 in] deep
- D: Drain connection
G^{1/4}; 12 mm [0.47 in] deep
- E: Release port
G^{1/4}; 12 mm [0.47 in] deep

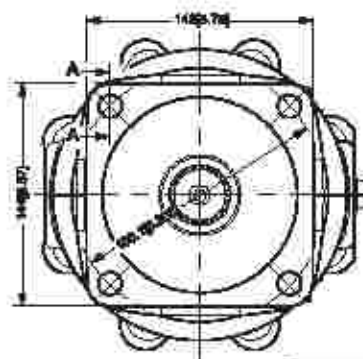
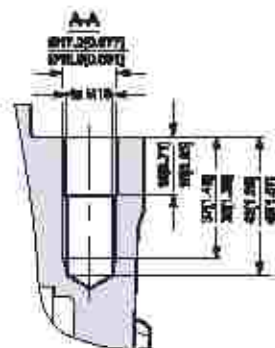
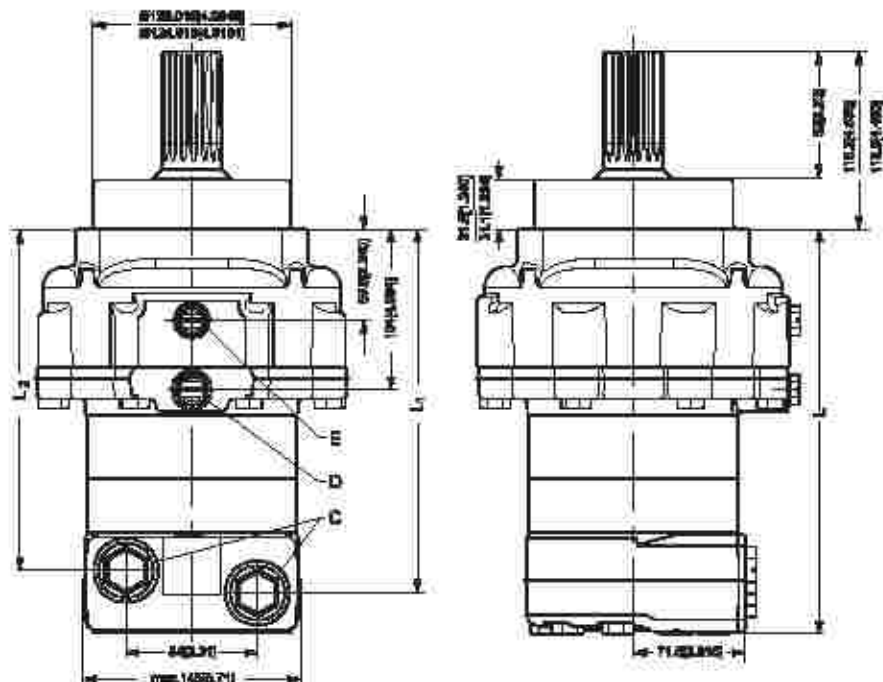

1215-0041_02



MT, TMTU, TMTW and TMT FL

Technical Information

Dimensions, US version

DIMENSIONS

4-Bolt flange-spigot diameter \varnothing 5 in, SAE C mounting flange- BC \varnothing 6.37 in

Type	L mm (in)	L ₁ mm (in)	L ₂ mm (in)
TMT 250 FL	259 [10.20]	232.5 [9.15]	218 [8.58]
TMT 315 FL	268.3 [10.56]	241.8 [9.52]	227.3 [8.95]
TMT 400 FL	278.8 [10.98]	252.3 [9.93]	237.8 [9.36]
TMT 470 FL	287 [11.30]	260.5 [10.26]	246 [9.69]
TMT 500 FL	278.8 [10.98]	252.3 [9.93]	237.8 [9.36]
TMT 630 FL	292.8 [11.53]	266.3 [10.48]	251.8 [9.91]

- C: 1 1/8-12 UN O-ring boss port; 19 mm [0.75 in] deep
- D: Drain connection 3/8-18 UNF O-ring boss port; 12.7 mm [0.5 in] deep
- E: Release port 7/8-20 UNF O-ring boss port; 12.7 mm [0.5 in] deep

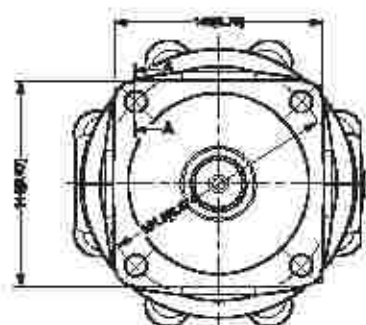
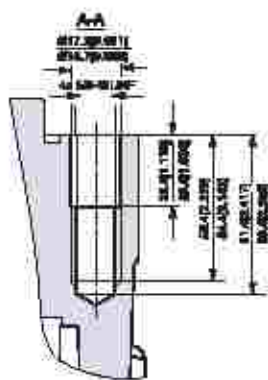
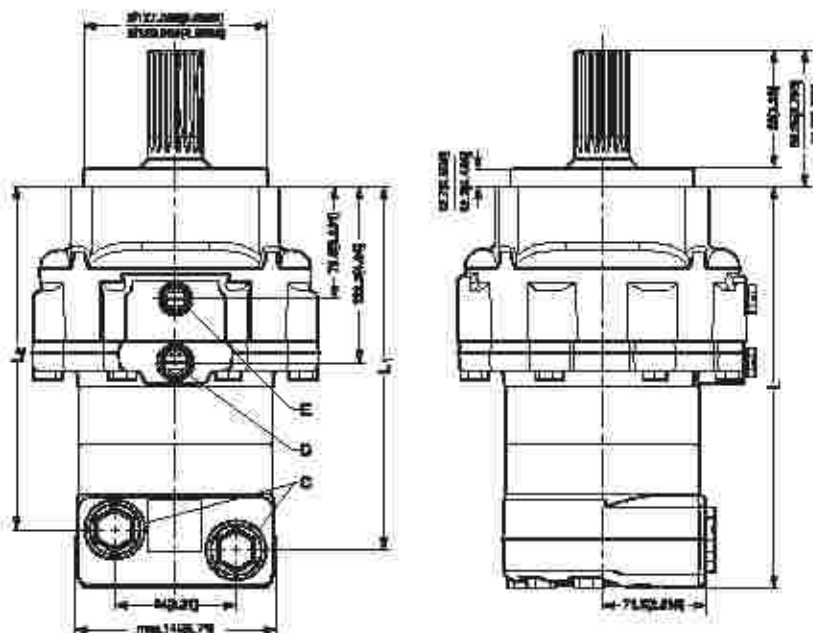



TMT, TMTW and TMT FL

Technical Information

Dimensions, US version

DIMENSIONS

4-Bolt flange-spigot diameter \varnothing 7.08 in, SAE C mounting flange- BC \varnothing 8.82 in

Type	L ₁ mm (in)	L ₂ mm (in)	L ₃ mm (in)
TMT 250 FL	232 [9.13]	205.5 [8.09]	191 [7.52]
TMT 315 FL	241.2 [9.50]	214.7 [8.45]	200.2 [7.88]
TMT 400 FL	251.7 [9.91]	225.2 [8.87]	210.7 [8.30]
TMT470 FL	260 [10.24]	233.5 [9.19]	219 [8.62]
TMT 500 FL	251.7 [9.91]	225.2 [8.87]	210.7 [8.30]
TMT 630 FL	265.7 [10.46]	239.2 [9.42]	224.7 [8.85]

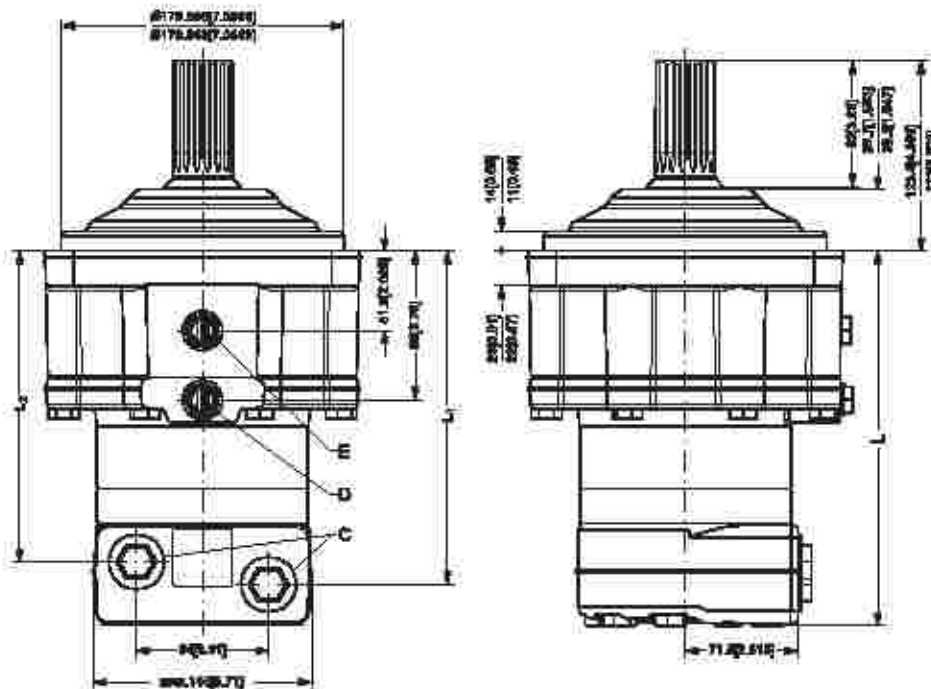

- C: 1/16-12 UN O-ring boss port; 19 mm [0.75 in] deep
- D: Drain connection 9/16-18 UNF O-ring boss port; 12.7 mm [0.5 in] deep
- E: Release port 7/16-20 UNF O-ring boss port; 12.7 mm [0.5 in] deep

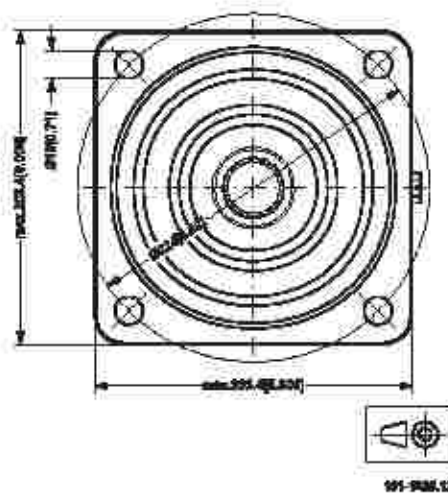



MT, TMTU, TMTW and TMT FL
 Technical Information
 Dimensions, European version

DIMENSIONS

4-Bolt flange-spigot diameter Ø 180 mm - BC Ø 224 mm

Type	L ₁ mm (in)	L ₂ mm (in)	L ₃ mm (in)
TMT 250 FL	232 [9.13]	205.5 [8.09]	191 [7.52]
TMT 315 FL	241.2 [9.50]	214.7 [8.45]	200.2 [7.88]
TMT 400 FL	251.7 [9.91]	225.2 [8.87]	210.7 [8.30]
TMT 470 FL	260 [10.24]	233.5 [9.19]	219 [8.62]
TMT 500 FL	251.7 [9.91]	225.2 [8.87]	210.7 [8.30]
TMT 630 FL	265.7 [10.46]	239.2 [9.42]	224.7 [8.85]

- C: G^{3/4}; 17 mm [0.67 in] deep
- D: Drain connection
 G^{1/4}; 12 mm [0.47 in] deep
- E: Release port
 G^{1/4}; 12 mm [0.47 in] deep

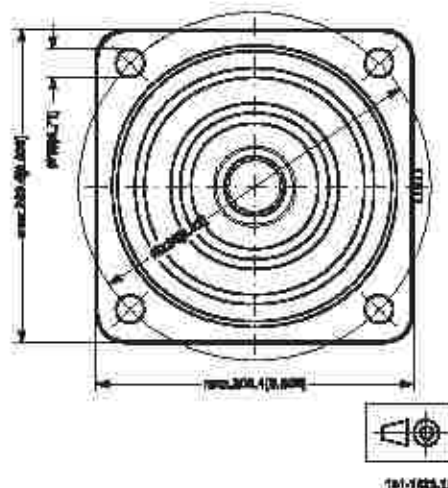
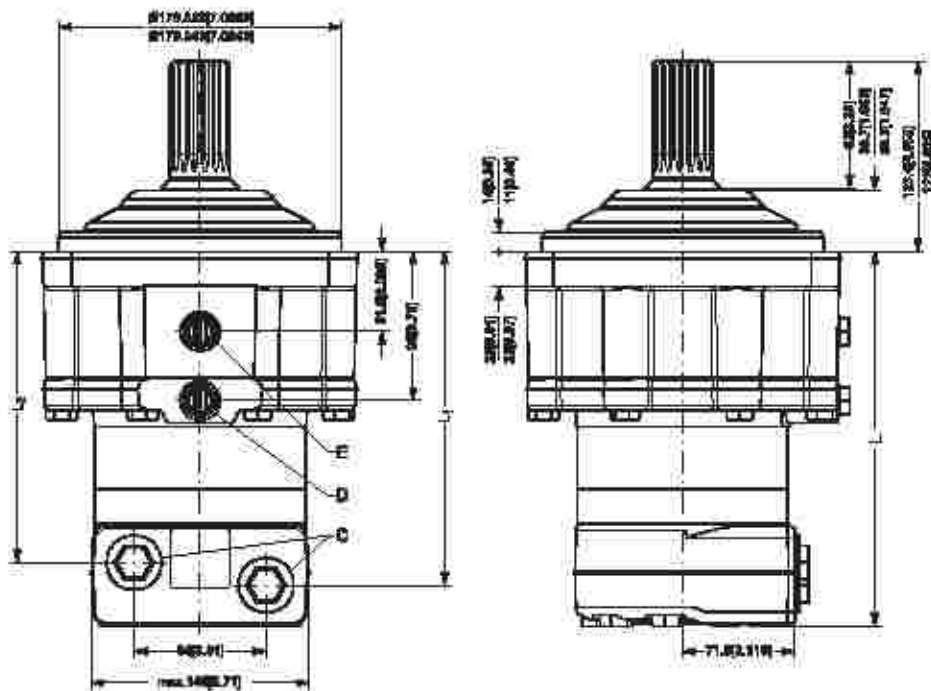



Technical Information
 Dimensions, European version

DIMENSIONS

Wheel - Spigot diameter Ø 180 mm - BC Ø 210 mm

Type	L ₁ mm (in)	L ₂ mm (in)
TMTW 250	250.1 [9.85]	99 [3.90]
TMTW 315	259.4 [10.21]	108.3 [4.26]
TMTW 400	269.9 [10.63]	118.8 [4.68]
TMTW 470	278.1 [10.95]	127 [5.00]
TMTW 500	269.9 [10.63]	118.8 [4.68]
TMTW 630	283.9 [11.18]	132.8 [5.23]

C: G^{3/4}; 17 mm [0.67 in] deep

D: Drain connection

G^{1/4}; 12 mm [0.47 in] deep

E: Ø 14.1

F: 3 x M14

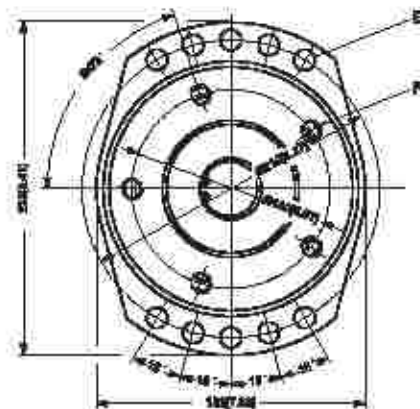
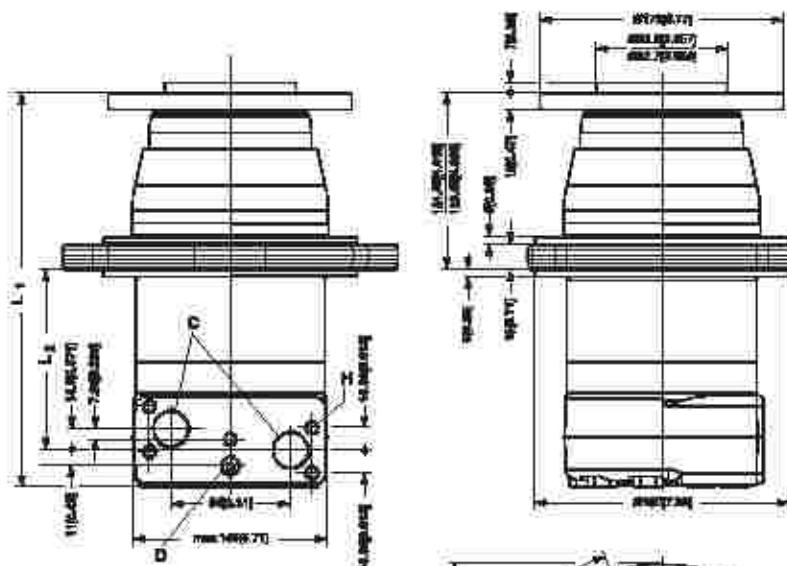

FIGURE 02



Technical Information

Weight of Motors

WEIGHT OF MOTORS

Code no	Weight	
	kg	[lb]
151Z3000	16.1	[35.49]
151Z3001	16.9	[37.26]
151Z3002	17.8	[39.24]
151Z3003	18.5	[40.79]
151Z3004	19.0	[41.89]
151Z3005	19.0	[41.89]
151Z3010	25.2	[55.56]
151Z3011	26.1	[57.54]
151Z3012	27.1	[59.75]
151Z3013	27.8	[61.29]
151Z3014	28.4	[62.61]
151Z3015	28.4	[62.61]
151Z3016	22.5	[49.60]
151Z3017	23.3	[51.37]
151Z3018	24.3	[53.57]
151Z3020	25.2	[55.56]
151Z3021	26.1	[57.54]
151Z3022	27.1	[59.75]
151Z3023	27.8	[61.29]
151Z3024	28.4	[62.61]
151Z3025	28.4	[62.61]
151Z3026	22.5	[49.60]
151Z3027	23.3	[51.37]
151Z3028	24.3	[53.57]
151Z3030	25.2	[55.56]
151Z3031	26.1	[57.54]
151Z3032	27.1	[59.75]
151Z3033	27.8	[61.29]
151Z3034	28.4	[62.61]
151Z3035	28.4	[62.61]
151Z3036	22.5	[49.60]
151Z3037	23.3	[51.37]
151Z3038	24.3	[53.57]
151Z3040	35.3	[77.82]
151Z3041	36.2	[79.81]
151Z3042	37.2	[82.01]
151Z3043	38.0	[83.78]
151Z3044	38.5	[84.88]
151Z3045	38.5	[84.88]
151Z3050	35.3	[77.82]
151Z3051	36.2	[79.81]
151Z3052	37.2	[82.01]
151Z3053	38.0	[83.78]
151Z3054	38.5	[84.88]
151Z3055	38.5	[84.88]

Code no	Weight	
	kg	[lb]
151Z3060	23.9	[52.69]
151Z3061	24.7	[54.45]
151Z3062	25.7	[56.66]
151Z3063	26.5	[58.42]
151Z3064	27.0	[59.52]
151Z3065	27.0	[59.52]
151Z3070	23.9	[52.69]
151Z3071	24.7	[54.43]
151Z3072	25.7	[56.66]
151Z3073	26.5	[58.42]
151Z3074	27.0	[59.52]
151Z3075	27.0	[59.52]
151Z3080	23.9	[52.69]
151Z3081	24.7	[54.45]
151Z3082	25.7	[56.66]
151Z3083	26.5	[58.42]
151Z3084	27.0	[59.52]
151Z3085	27.0	[59.52]
151Z3090	36.7	[80.91]
151Z3091	37.6	[82.89]
151Z3092	38.6	[85.10]
151Z3093	39.4	[86.86]
151Z3094	39.9	[87.96]
151Z3095	39.9	[87.96]
151Z3100	16.1	[35.49]
151Z3101	16.9	[37.26]
151Z3102	17.8	[39.24]
151Z3103	18.5	[40.79]
151Z3104	19.0	[41.89]
151Z3105	19.0	[41.89]
151Z3110	39.5	[87.08]
151Z3111	40.4	[89.07]
151Z3112	41.4	[91.27]
151Z3113	42.2	[93.03]
151Z3114	42.7	[94.14]
151Z3115	42.7	[94.14]
151Z3120	39.5	[87.08]
151Z3121	40.4	[89.07]
151Z3122	41.4	[91.27]
151Z3123	42.2	[93.03]
151Z3124	42.7	[94.14]
151Z3125	42.7	[94.14]
151Z3130	39.5	[87.08]
151Z3131	40.4	[89.07]
151Z3132	41.4	[91.27]
151Z3133	42.2	[93.03]
151Z3134	42.7	[94.14]
151Z3135	42.7	[94.14]

Code no	Weight	
	kg	[lb]
151Z3229	27.6	[60.85]
151Z3230	28.4	[62.61]
151Z3231	29.3	[64.60]
151Z3232	30.0	[66.14]
151Z3233	30.5	[67.24]
151Z3234	30.5	[67.24]
151Z3273	27.6	[60.85]
151Z3274	28.4	[62.61]
151Z3275	29.3	[64.60]
151Z3276	30.0	[66.14]
151Z3277	30.5	[67.24]

 www.khadamathydraulic.com

Tell: 021-55882749

Tell: 021-33488178

Fax: 021-33488105



MT, TMTU, TMTW and TMT FL
Technical Information
Notes



OUR PRODUCTS

Hydrostatic transmissions

Hydraulic power steering

Electro-hydraulic power steering

Electric power steering

Closed and open circuit axial piston pumps and motors

Gear pumps and motors

Bent axis motors

Orbital motors

Transit mixer drives

Planetary compact gears

Proportional valves

Directional spool valves

Cartridge valves

Hydraulic integrated circuits

Hydrostatic transaxles

Integrated systems

Fan drive systems

Electrohydraulic controls

Digital electronics and software

Electric motors and inverters

Sensors

Sauer-Danfoss Hydraulic Power Systems – Market Leaders Worldwide

Sauer-Danfoss is a comprehensive supplier providing complete systems to the global mobile market.

Sauer-Danfoss serves markets such as agriculture, construction, road building, material handling, municipal, forestry, turf care, and many others.

We offer our customers optimum solutions for their needs and develop new products and systems in close cooperation and partnership with them.

Sauer-Danfoss specializes in integrating a full range of system components to provide vehicle designers with the most advanced total system design.

Sauer-Danfoss provides comprehensive worldwide service for its products through an extensive network of Authorized Service Centers strategically located in all parts of the world.

Sauer-Danfoss (US) Company
2800 East 13th Street
Ames, IA 50010, USA
Phone: +1 515 239-6000, Fax: +1 515 239-6618

Sauer-Danfoss (Neumünster) GmbH & Co. OHG
Postfach 2460, D-24531 Neumünster
Krokamp 35, D-24539 Neumünster, Germany
Phone: +49 4321 871-0, Fax: +49 4321 871-122

Sauer-Danfoss (Nordborg) A/S
DK-6430 Nordborg, Denmark
Phone: +45 7488 4444, Fax: +45 7488 4400