

Proportionalventile DSP mit OBE

Proportional valves DSP with OBE

Valves proportionnels DSP avec OBE

1

NEU

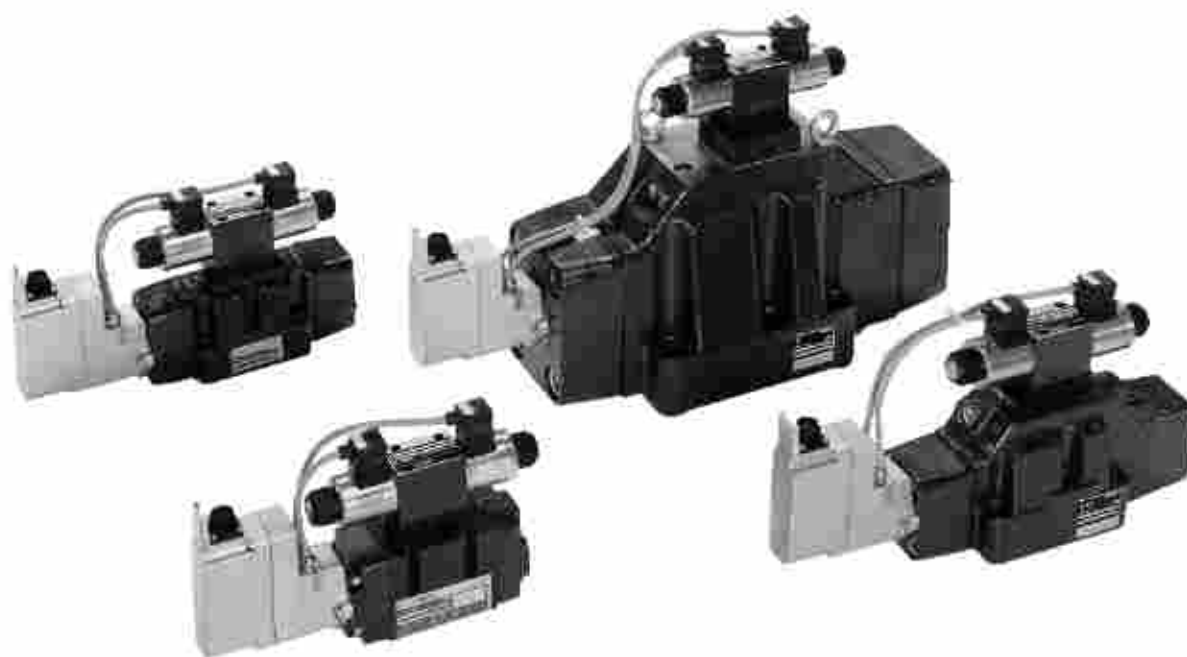

▶ Neue Baureihe „DSP“ Double Solenoid Proportional valves

- Hauptstufe lagegeregelt mit OBE
- Vorsteuerventil, ohne Lageregelung, mit getrennten Magneten:
Magnet „a“ regelt das Symbol P-B
Magnet „b“ regelt das Symbol P-A der Hauptstufe.

Kostengünstige Baureihe mit OBE und einfache Einbindung in Sicherheitsschaltungen (siehe Seite 30),

▶▶ New series “DSP” Double Solenoid Proportional valves

- Main stage position-controlled with OBE
- Pilot valve without position control, with separate solenoids:
Solenoid “a” controls the symbol P-B
Solenoid “b” controls the symbol P-A of the main stage.

Low-cost series with OBE, permitting simple integration in safety circuits (see page 30).

▶▶▶ Nouvelle série «DSP» Double Solenoid Proportional valves

- Etage principal asservi en position avec OBE
- Valve pilote, sans régulation de position, avec électro-aimants séparés:
L'électro-aimant «a» régule le symbole P-B, l'électro-aimant «b» le symbole P-A de l'étage principal.

Série de coût avantageux avec OBE et intégration facile dans des circuits de sécurité (voir page 30).

1

Proportionalventile DSP mit OBE

Proportional valves DSP with OBE

Valves proportionnels DSP avec OBE



Funktion
Function
Fonction

CE EN 50 081-1
EN 50 082-2

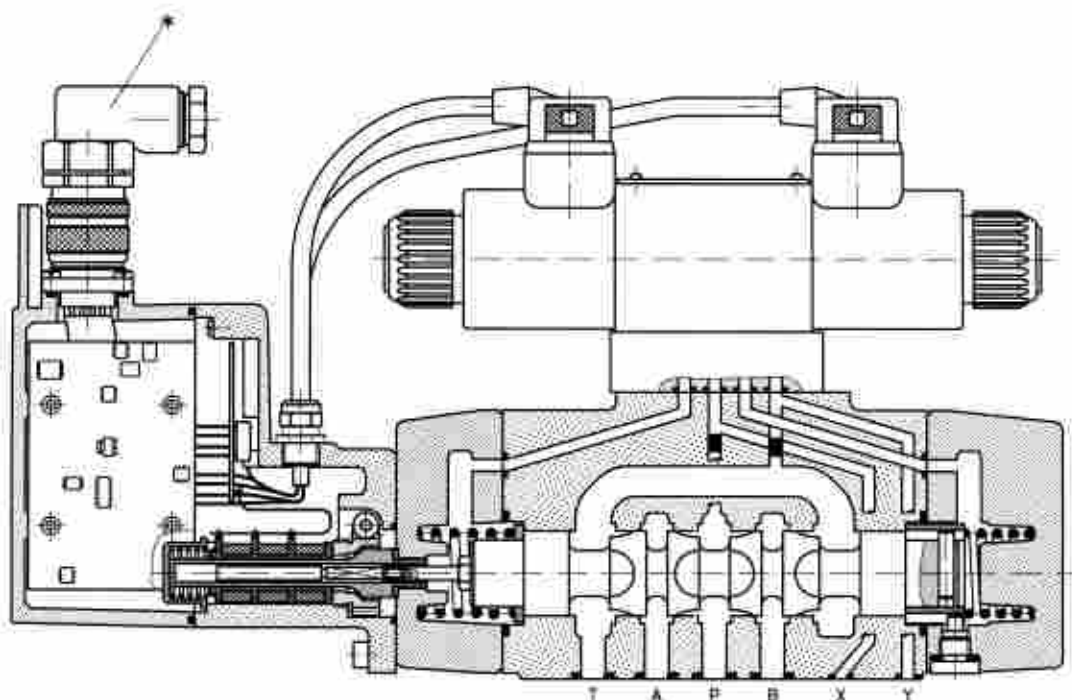

► **Hinweis:**

Bei NG 25(32) und NG 32(50) sind die hydraulischen Anschlüsse im Durchmesser größer dimensioniert als die Norm vorgibt. DSP-Ventile der Nenngrößen 25 und 32 bieten daher höhere Durchflußwerte $Q_A : Q_B$ (siehe Seite 17). In den Maßzeichnungen werden die max. \varnothing in mm der Anschlüsse P, A, B, T angegeben.

* 90°-Stecker 1 834 484 252 bevorzugt einsetzen, nicht im Lieferumfang enthalten.

►► **Note:**







The hydraulic ports of valves NG 25 (32) and NG 32 (50) have larger diameters than those stipulated by the standard. DSP valves size 25 and 32 therefore permit higher flow values $Q_A : Q_B$ (see page 17). In the dimensional drawings, the max. \varnothing of ports P, A, B and T are stated in mm.

* Use of the 90° plug 1 834 484 252 (not included in the scope of delivery) is preferable.

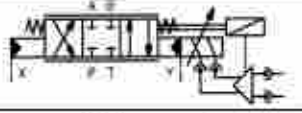
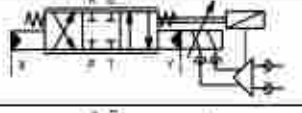
►►► **Remarque:**

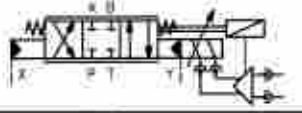
Pour NG 25 (32) et NG 32 (50), les orifices hydrauliques sont dimensionnés avec un diamètre plus important que celui prescrit par la norme. Les valves DSP des tailles 25 et 32 présentent donc des débits plus importants $Q_A : Q_B$ (voir page 17). Sur les schémas cotés, les diamètres max. des orifices P, A, B, T sont indiqués en mm.

* Utiliser de préférence le connecteur coudé à 90° 1 834 484 252, non compris dans la fourniture.

Sinnbild Symbol Symbole	NG	Q _{max} (Δp = 5 bar) [l/min] Q _A : Q _B	P _{max} [bar]	Steueröl Control oil Pilotage		 V/VA max	[kg]	⊕
				X	Y			
	10	80 : 80	P, A, B: 350 T: 250 X: 280 Y: 50	ext.	ext.	24 V= 40 VA max U _{0-ε} 0 ... ±10V	9,1	0 811 404 911
		80 : 50		ext.	ext.			0 811 404 912
		80 : 80		ext.	ext.			0 811 404 915
		80 : 50		ext.	ext.			0 811 404 916
		80 : 50		ext.	ext.			0 811 404 920
	16	180 : 180	P, A, B: 280 T: 200 X: 280 Y: 50	ext.	ext.		11,0	0 811 404 926
		180 : 180		int.	ext.			0 811 404 926
		180 : 110		ext.	ext.			0 811 404 927
		180 : 110		int.	ext.			0 811 404 928
		180 : 180		ext.	ext.			0 811 404 930
		180 : 180		int.	ext.			0 811 404 932
		180 : 110		ext.	ext.			0 811 404 931
		180 : 110		int.	ext.			0 811 404 933
		180 : 110		ext.	ext.			0 811 404 937
		180 : 110		int.	ext.			Auf Anfrage On request Sur demande
	25 (32)	430 : 430	P, A, B: 280 T: 200 X: 280 Y: 50	ext.	ext.		18,8	0 811 404 950
		430 : 430		int.	ext.			0 811 404 954
		430 : 230		ext.	ext.			0 811 404 951
		430 : 230		int.	ext.			0 811 404 955
		430 : 430		ext.	ext.			0 811 404 956
		430 : 430		int.	ext.			0 811 404 962
		430 : 230		ext.	ext.			0 811 404 959
		430 : 230		int.	ext.			0 811 404 963
		430 : 230		ext.	ext.			Auf Anfrage On request Sur demande
		430 : 230		int.	ext.			
	32 (50)	1100 : 1100	P, A, B: 350 T: 200 X: 280 Y: 50	ext.	ext.		80,8	0 811 404 975
		1100 : 1100		ext.	ext.			0 811 404 979
		1100 : 1100		ext.	ext.			Auf Anfrage On request Sur demande
	10	4x M6 x 40			DIN 912-10.9			2 910 151 209
	16	2x M6 x 45			DIN 912-10.9			2 910 151 211
		4x M10 x 50						2 910 151 301
	25	6x M12 x 60			DIN 912-10.9			2 910 151 354
	32	6x M20 x 80			DIN 912-10.9			2 910 151 532
	Stecker, 7 polig					KS		1 834 482 022
	Plug 7-pole					KS		1 834 482 026
	Connecteur 7 pôles					MS		1 834 482 023
	Seite					MS		1 834 482 024
	Page 118					KS 90°		1 834 484 252
	ISA-Adapter für externe Magnetabschaltung							1 834 484 245
	ISA adapter for external solenoid shut-off							Seite Page 30
Adaptateur ISA pour coupure externe de l'électro-aimant								

1

Kenngrößen



Allgemein

Bauart	Schieberventil, vorgesteuert		
Betätigung	Vorgesteuert, Proportional 4/3-Wegeventil NG 6, ohne Lageregelung		
Hauptstufe	Lagegeregelt, mit OBE an der Hauptstufe		
Anschlußart	Plattenanschluß, Lochbild nach ISO 4401		
Einbaulage	beliebig		
Umgebungstemperatur	-20 °C ... +50 °C		
Rüttelfestigkeit	max. 25 g, Raumschüttelprüfung		
Prüfbedingung	in allen Richtungen (24 h)		

Hydraulisch

Druckmittel	Hydrauliköl nach DIN 51 524 ... 535, andere Medien nach Rückfrage		
Viskosität, empfohlen	20 ... 100 mm ² /s		
max. zulässig	10 ... 800 mm ² /s		
Druckmitteltemperatur	-20 ... +70 °C		
Filterung	Zulässige Verschmutzungs-kategorie des Druckmittels nach NAS 1638	Zu erreichen mit Filter $\beta_1 = 75$	
Entsprechend Betriebs-sicherheit und Lebensdauer	8	X = 10	
	9	20	
	10	25	

Durchflußrichtung

Neandurchfluß [l/min]	Siehe Sinnbild			
bei $\Delta p = 5$ bar pro Kante *	NG 10	NG 16	NG 25/32	NG 32/50
Max. Betriebsdruck in P, A, B	80	180	430	1100
Max. Druck in X (ext.)	350	350	280	350
Max. Druck in P (X = int.)			280	
Max. Druck in T (Y = ext.)			250	
Max. Druck in T (Y = int.)			50	
Max. Druck in Y (ext.)			50	
Min. Steueröldruck „Vorsteuerstufe“			15	
Q_{max} [l/min]	170	450	1200	3000
Q_{II} Vorsteuerventil (Zulauf) $\Delta p = 5$ bar	5	6,5	22	22
Lecköl [cm ³ /min]	< 240	< 260	< 300	< 300
Vorsteuerventil bei 100 bar				
Lecköl [l/min]	< 0,25	< 0,4	< 0,6	< 1,2
Hauptstufe Sb 01 bei 100 bar				
Q_{II} , Sb 01 + L, siehe Diagramm Seite 14				

Statisch/Dynamisch

Überdeckung in Mittelstellung	≈ 18 ... 22% vom Schieberhub, elektrisch kompensiert für $U_{D-E} \pm 0,5$ V			
Schieberhub, Hauptstufe [± mm]	4	7	10	12,5
Steuerölvolumen Hauptstufe 100% [cm ³]	1,1	4,3	11,3	41,5
Steuerölbedarf 0 ... 100%, $x = 100$ bar [l/min]	2,2	4,7	11,7	15,6
Hysterese	< 0,3%			
Positioniergenauigkeit	< 0,5%			
Exemplarstreuung	< ± 5% (Q_{max})			
Stellzeit für Signalsprung 0 ... 100% ($x = 100$ bar) [ms]	< 35	< 55	< 60	< 140
Ausschaltverhalten	Nach elektrischer Abschaltung (Vorsteuerventil in Mittelstellung) Hauptstufe nimmt die zentrierte Mittelstellung ein (Sb 01/Sb 01+L)			
Temperaturdrift	< 1% bei $\Delta T = 40$ °C			
Kalibrierung	Ab Werk ± 1%, siehe Durchflußkennlinien			
Konformität	EN 50 081-1 EN 50 082-2			
Elektrische Kenngrößen	siehe Seite 111 (OBE)			

* **Neandurchfluß**

Dieser bezieht sich immer auf eine Druckdifferenz an der Drosselseite von $\Delta p = 5$ bar. Der Durchfluß bei anderen Differenzdrücken berechnet sich nach:

$$Q_s = Q_{nom} \cdot \sqrt{\frac{\Delta p_s}{5}}$$



Characteristics

General

Construction	Spool valve, pilot operated
Actuation	Pilot operated, proportional 4/3 DCV NG 6, without position control
Main stage	Position-controlled, with OBE at main stage
Type of mounting	Subplate, mounting hole configuration to ISO 4401
Installation position	Optional
Ambient temperature	-20 °C ... +50 °C
Vibration resistance test conditions	Max. 25 g, shaken in 3 dimensions (24 h)

Hydraulic

Pressure fluid	Hydraulic oil to DIN 51 524 ... 535, other fluids after prior consultation		
Viscosity, recommended	20 ... 100 mm ² /s		
max. permitted	10 ... 800 mm ² /s		
Pressure fluid temp.	-20 ... +70 °C		
Filtration	Permissible contamination class of pressure fluid to NAS 1638	Achieved with filter β ₁ = 75	
In line with operational reliability and service life	18	X = 10	
	19	X = 20	
	10	X = 25	

Direction of flow	See symbol			
Nominal flow [l/min]	NG 10	NG 18	NG 25/32	NG 32/50
at Δp = 5 bar per notch *	80	180	430	1100
Max. working pressure in P, A, B	350	350	280	350
Max. pressure in X (ext.)			280	
Max. pressure in P (X = int.)			280	
Max. pressure in T (Y = ext.)			250	
Max. pressure in T (Y = int.)			50	
Max. pressure in Y (ext.)			50	
Min. control oil pressure, "pilot stage"			15	
Q _{nom} [l/min]	170	450	1200	3000
Q _M pilot valve (supply pressure) Δp = 5 bar	5	8.5	22	22
Leakage [cm ³ /min]	<240	<260	<300	<300
Pilot valve at 100 bar				
Leakage [l/min]	<0.25	<0.4	<0.6	<1.2
Main stage Sb 01 at 100 bar				
Q _N : Sb 01 + L, see graph on page 14				

Static/Dynamic

Overlap in centre position	≈ 18 ... 22% of spool stroke, electrically compensated for U _{0-E} ± 0.5 V			
Spool stroke, main stage [± mm]	4	7	10	12.5
Control oil volume of main stage 100% [cm ³]	1.1	4.3	11.3	41.5
Control oil requirement 0 ... 100%, x = 100 bar [l/min]	2.2	4.7	11.7	15.6
Hysteresis	< 0.3%			
Positioning accuracy	< 0.5%			
Manufacturing tolerance	< ± 5% (Q _{nom})			
Response time for signal change 0 ... 100% (x = 100 bar) [ms]	< 35	< 55	< 60	< 140
Switch-off behaviour	After electrical shut-off (pilot valve in centre position) Main stage moves to centred middle position (Sb01/Sb 01 + L)			
Thermal drift	< 1% at ΔT = 40 °C			
Calibration	Calibrated at the factory ± 1%, see flow curves			
Conformity	EN 50 081-1 EN 50 082-2			
Electrical characteristics	See page 111 (OBE)			

*** Nominal flow**

This is always based on a pressure differential of Δp = 5 bar at the throttle point.

Where other pressure differentials are involved, flow is calculated according to the following formula:

$$Q_x = Q_{nom} \cdot \sqrt{\frac{\Delta p_x}{5}}$$

1



Caractéristiques

Générales

Construction	Distributeur à tiroir, piloté		
Commande	Distributeur proportionnel piloté 4/3 NG 6; sans régulation de position		
Étage principal	Asservi en position, avec OBE sur l'étage principal		
Raccordement	Embase selon plan de pose ISO 4401		
Position de montage	indifférente		
Température ambiante	-20 °C ... +50 °C		
Résistance aux vibrations	max. 25 g.		
Condition du test	3 dimensions (24 h)		

Hydrauliques

Fluid	Huile hydraulique selon norme DIN 51 524 ... 535, autre fluide sur demande		
Viscosité conseillée	20 ... 100 mm ² /s		
max. admissible	10 ... 800 mm ² /s		
Température du fluide	-20 ... +70 °C		
Filtration	Classe de pollution admissible du fluide selon NAS 1638	Avec un filtre β _s = 75	
Selon la sécurité de fonctionnement et la durée de vie	18	X = 10	
	19	X = 20	
	10	X = 25	

Sens d'écoulement

voir symbole

Débit nominal [l/min]	NG 10	NG 16	NG 25/32	NG 32/50
pour Δp = 5 bar par arête*	80	180	430	1100
Pression de service max. en P, A, B	350	350	280	350
Pression max. en X (ext.)			280	
Pression max. en P (X = int.)			280	
Pression max. en T (Y = ext.)			250	
Pression max. en T (Y = int.)			50	
Pression max. en Y (ext.)			50	
Pression huile de pilotage min. «étage pilote»			15	
Q _{max} [l/min]	170	450	1200	3000
Q _v valve pilote (arrivée) Δp = 5 bar	5	6,5	22	22
Fuites internes [cm ³ /min] valve pilote à 100 bar	<240	<260	<300	<300
Fuites internes [l/min] étage principal Sb 01 à 100 bar	<0,25	<0,4	<0,6	<1,2
Q _v : Sb 01 + L, voir diagramme page 14				

Statiques/dynamiques

Recouvrement en position médiane	≈18 ... 22% de la course du tiroir, compensé électriquement pour U _{0-ε} ±0,5 V			
Course du tiroir, étage principal [± mm]	4	7	10	12,5
Volume huile de pilotage étage principal 100% [cm ³]	1,1	4,3	11,3	41,5
Besoins huile de pilotage 0 ... 100%, x = 100 bar [l/min]	2,2	4,7	11,7	15,6
Hystérésis	<0,3%			
Précision de positionnement	<0,5%			
Dispersion	<±5% (Q _{max})			
Temps de réponse pour une course de 0 ... 100% [ms] (x = 100 bar)	<35	<55	<60	<140
Comportement en cas de coupure	Après coupure électrique (valve pilote en position médiane) L'étage principal retourne en position médiane centrée (Sb01/Sb 01 + L)			
Dérive en température	<1% pour ΔT = 40 °C			
Tarage	A l'usine ±1%, voir courbes caractéristiques du débit			
Conformité	EN 50 081-1 EN 50 082-2			
Caractéristiques électriques	voir page 111 (OBE)			

*** Débit nominal**

Toujours par rapport à une différence de pression à l'étranglement de Δp = 5 bar.
 Le débit pour d'autres différences de pression se calcule comme suit:

$$Q_x = Q_{nom} \cdot \sqrt{\frac{\Delta p_i}{5}}$$

Kennlinien

**Performance curves
 Courbes caractéristiques**

$\Delta p = 5 \text{ bar}$
 $v = 36 \text{ mm}^2/\text{s}$

NG 10

$Q_A : Q_B = 80:80 \text{ l/min.}$

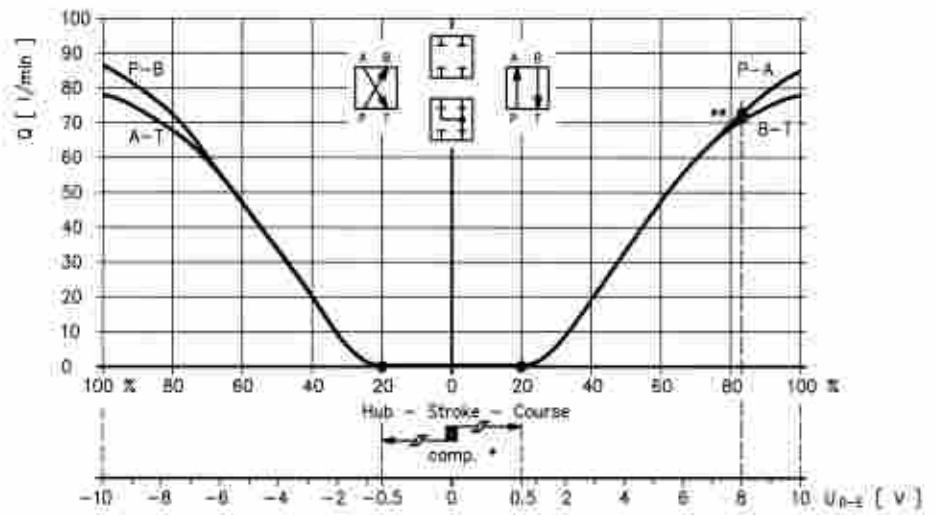

$Q_A : Q_B = 80:50 \text{ l/min.}$

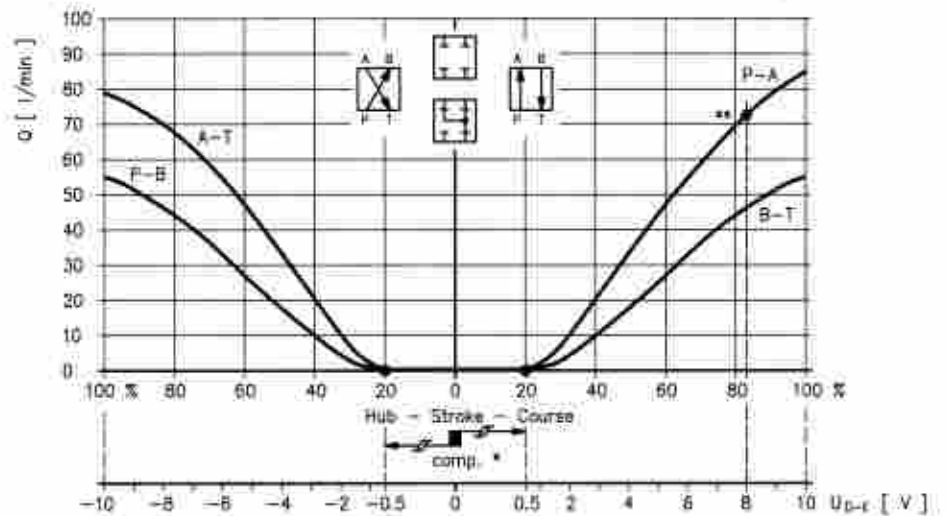

$Q_A : Q_B = 80:50 \text{ l/min.}$

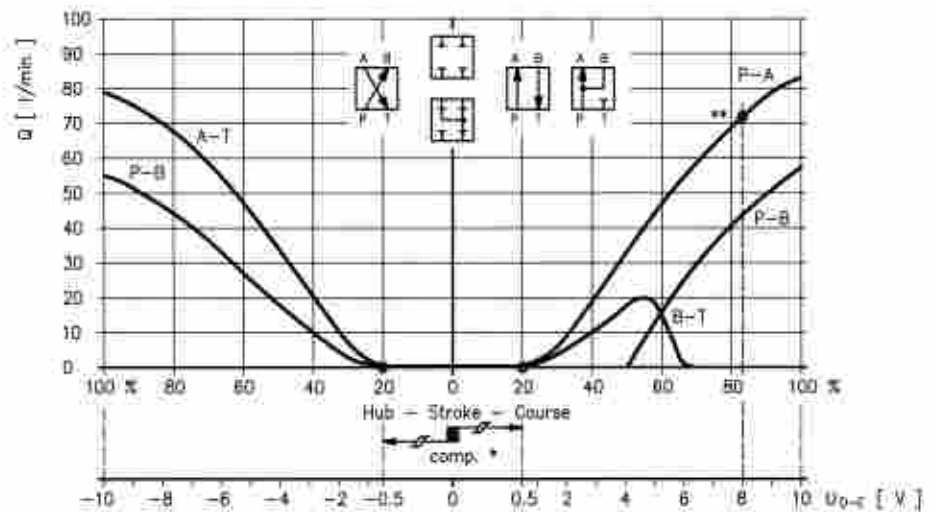

►
 * Comp. $U_{D-E} \pm 0,5 \text{ V}$
 Werkseinstellung $\pm 1 \%$
 ** Q_{P-A} bei $+ 8 \text{ V } [U_{D-E}]$
 Exemplarstreuung $Q_{\text{max}} \cong \pm 5 \%$

►►
 * Comp. $U_{D-E} \pm 0,5 \text{ V}$
 Factory setting $\pm 1 \%$
 ** Q_{P-A} at $+ 8 \text{ V } [U_{D-E}]$
 Manufacturing tolerance $Q_{\text{max}} \cong \pm 5 \%$

►►►
 * Comp. $U_{D-E} \pm 0,5 \text{ V}$
 Réglage à l'usine $\pm 1 \%$
 ** Q_{P-A} pour $+ 8 \text{ V } [U_{D-E}]$
 Dispersion $Q_{\text{max}} \cong \pm 5 \%$

1

Kennlinien
Performance curves
Courbes caractéristiques

$\Delta p = 5 \text{ bar}$
 $v = 36 \text{ mm}^2/\text{s}$

NG 16

$Q_A : Q_B = 180:180 \text{ l/min.}$

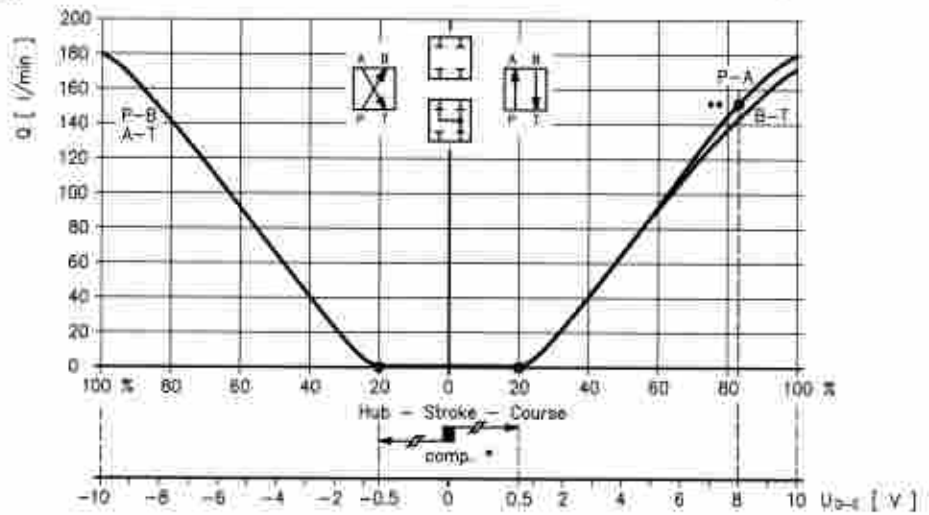

$Q_A : Q_B = 180:110 \text{ l/min.}$

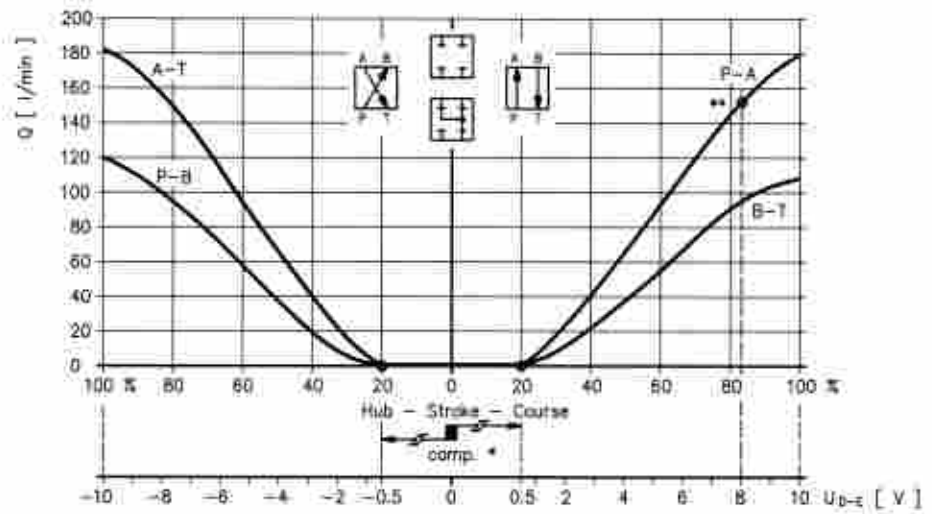

$Q_A : Q_B = 180:110 \text{ l/min.}$

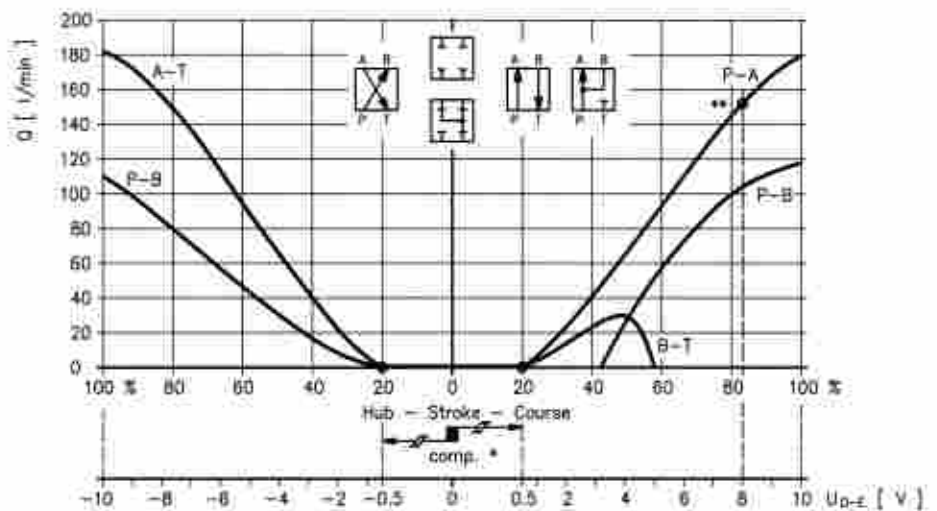

► * Comp. $U_{D-E} \pm 0,5 \text{ V}$
 Werkseinstellung $\pm 1 \%$
 ** Q_{P-A} bei $+8 \text{ V } [U_{D-E}]$
 Exemplarstreuung $Q_{\text{max}} \leq \pm 5 \%$

►► * Comp. $U_{D-E} \pm 0,5 \text{ V}$
 Factory setting $\pm 1 \%$
 ** Q_{P-A} at $+8 \text{ V } [U_{D-E}]$
 Manufacturing tolerance $Q_{\text{max}} \leq \pm 5 \%$

►►► * Comp. $U_{D-E} \pm 0,5 \text{ V}$
 Réglage à l'usine $\pm 1 \%$
 ** Q_{P-A} pour $+8 \text{ V } [U_{D-E}]$
 Dispersion $Q_{\text{max}} \leq \pm 5 \%$

Kennlinien
Performance curves NG 25 (32)
Courbes caractéristiques
 $\Delta p = 5 \text{ bar}$
 $v = 36 \text{ mm}^2/\text{s}$

$Q_A : Q_B = 430; 430 \text{ l/min.}$

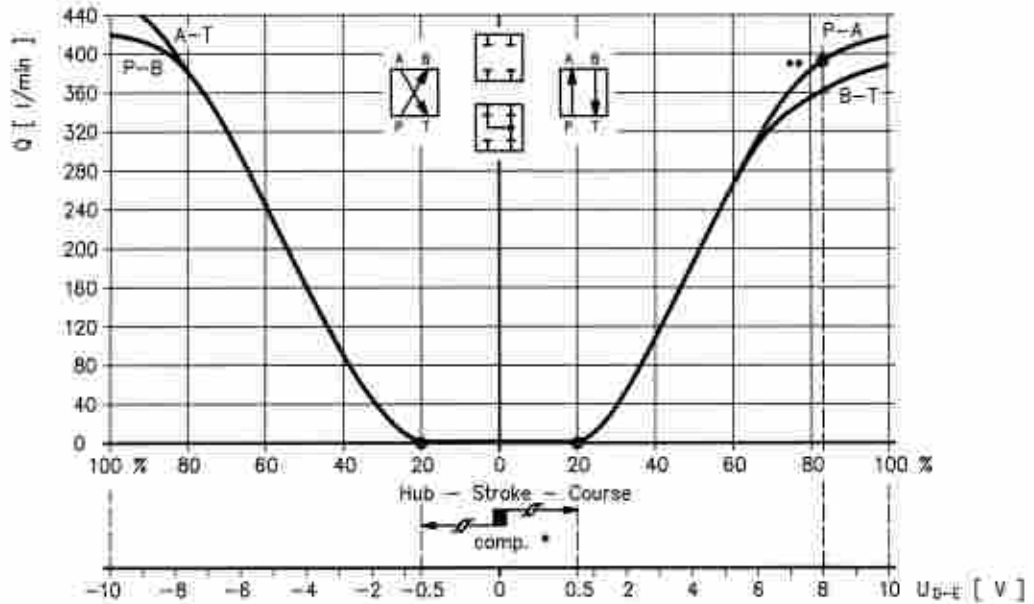

$Q_A : Q_B = 430; 230 \text{ l/min.}$

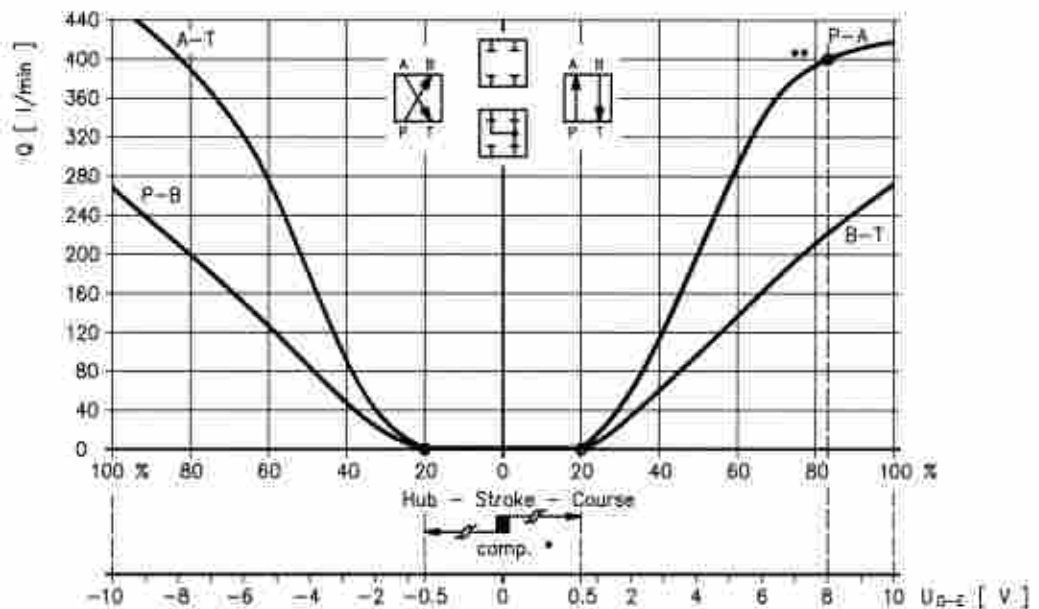

►
 * Comp. $U_{D-E} \pm 0,5 \text{ V}$
 Werkseinstellung $\pm 1 \%$
 ** Q_{P-A} bei $+ 8 \text{ V } [U_{D-E}]$
 Exemplarstreuung $Q_{\text{max}} \cong \pm 5 \%$

►►
 * Comp. $U_{D-E} \pm 0,5 \text{ V}$
 Factory setting $\pm 1 \%$
 ** Q_{P-A} at $+ 8 \text{ V } [U_{D-E}]$
 Manufacturing tolerance $Q_{\text{max}} \cong \pm 5 \%$

►►►
 * Comp. $U_{D-E} \pm 0,5 \text{ V}$
 Réglage à l'usine $\pm 1 \%$
 ** Q_{P-A} pour $+ 8 \text{ V } [U_{D-E}]$
 Dispersion $Q_{\text{max}} \cong \pm 5 \%$

Kennlinien
Performance curves
Courbes caractéristiques

NG 32 (50)

$\Delta p = 5 \text{ bar}$
 $v = 36 \text{ mm}^2/\text{s}$

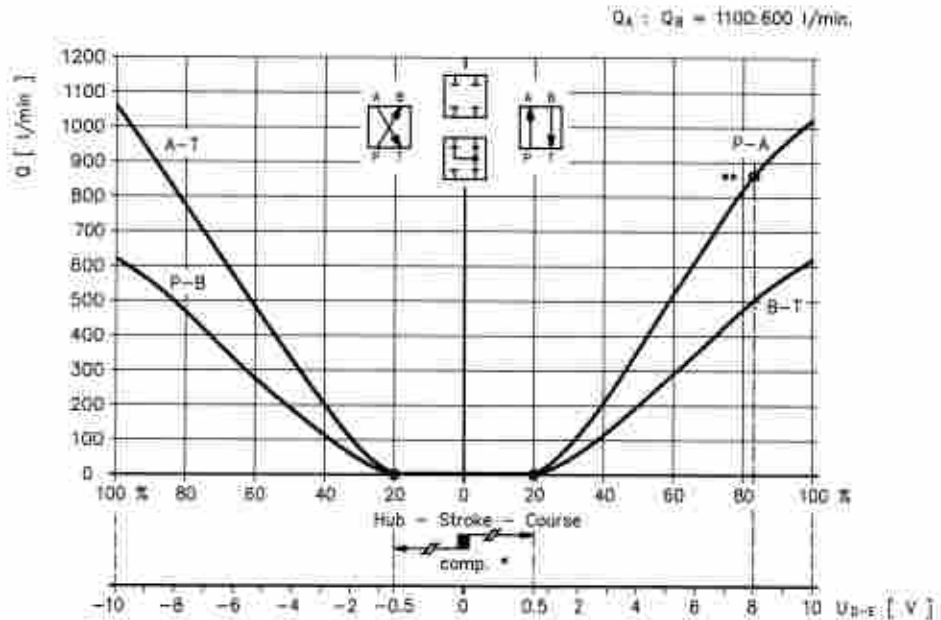
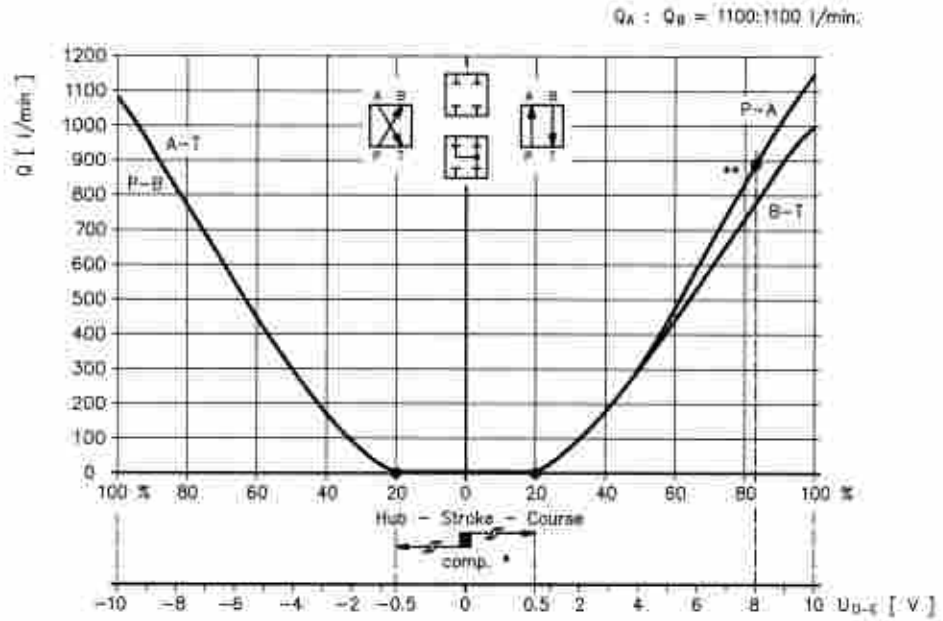

► • Comp. $U_{D-E} \pm 0,5 \text{ V}$
 Werkseinstellung $\pm 1 \%$
 ** Q_{P-A} bei $+8 \text{ V } [U_{D-E}]$
 Exemplarstreuung $Q_{\text{max}} \leq \pm 5 \%$

►► • Comp. $U_{D-E} \pm 0,5 \text{ V}$
 Factory setting $\pm 1 \%$
 ** Q_{P-A} at $+8 \text{ V } [U_{D-E}]$
 Manufacturing tolerance $Q_{\text{max}} \leq \pm 5 \%$

►►► • Comp. $U_{D-E} \pm 0,5 \text{ V}$
 Réglage à l'usine $\pm 1 \%$
 ** Q_{P-A} pour $+8 \text{ V } [U_{D-E}]$
 Dispersion $Q_{\text{max}} \leq \pm 5 \%$

Stellzeit
 Response time
 Temps de réponse

x = 100 bar

Öffnen
 Opening
 Ouverture

Schließen
 Closing
 Fermeture

NG 10

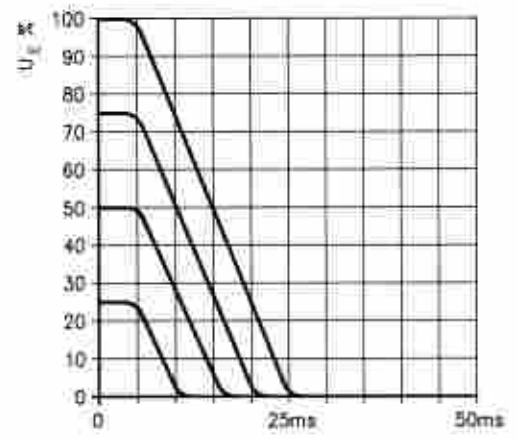
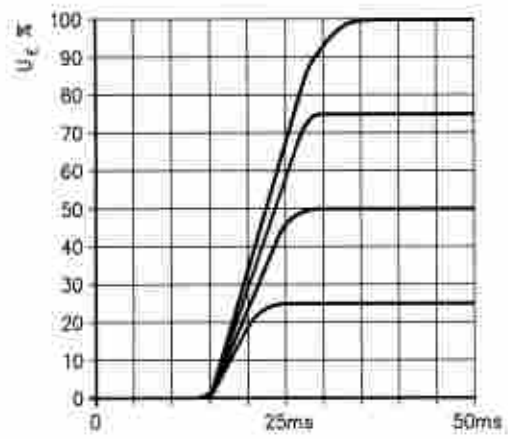

NG 16

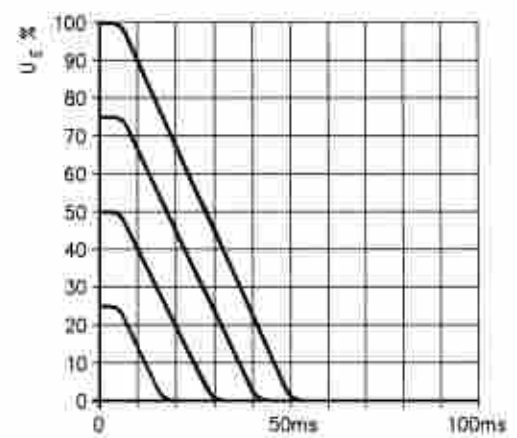
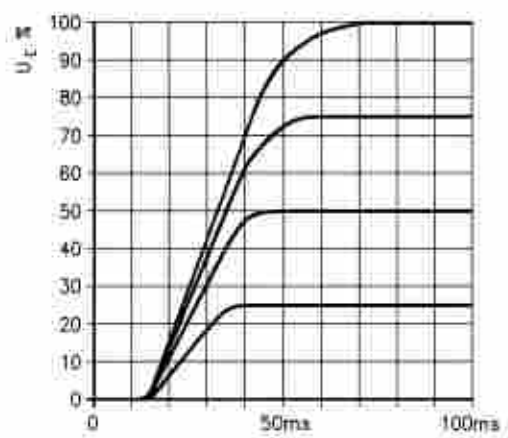

NG 25 (32)

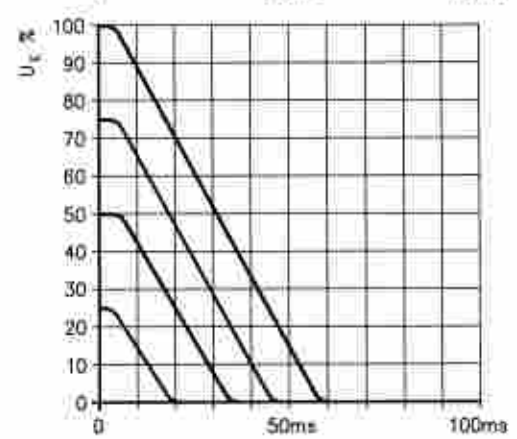
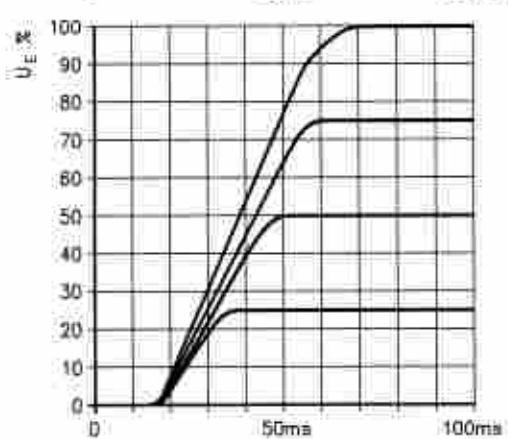

NG 32 (50)

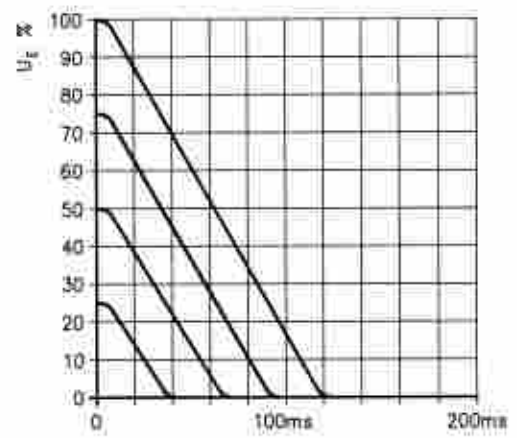
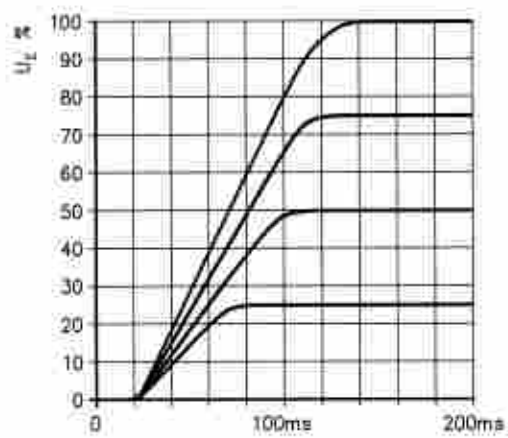

1

**Abmessungen
 Dimensions
 Cotes d'encombrement**

NG 10

nicht im Lieferumfang enthalten
 not included in scope of delivery
 non compris dans la fourniture

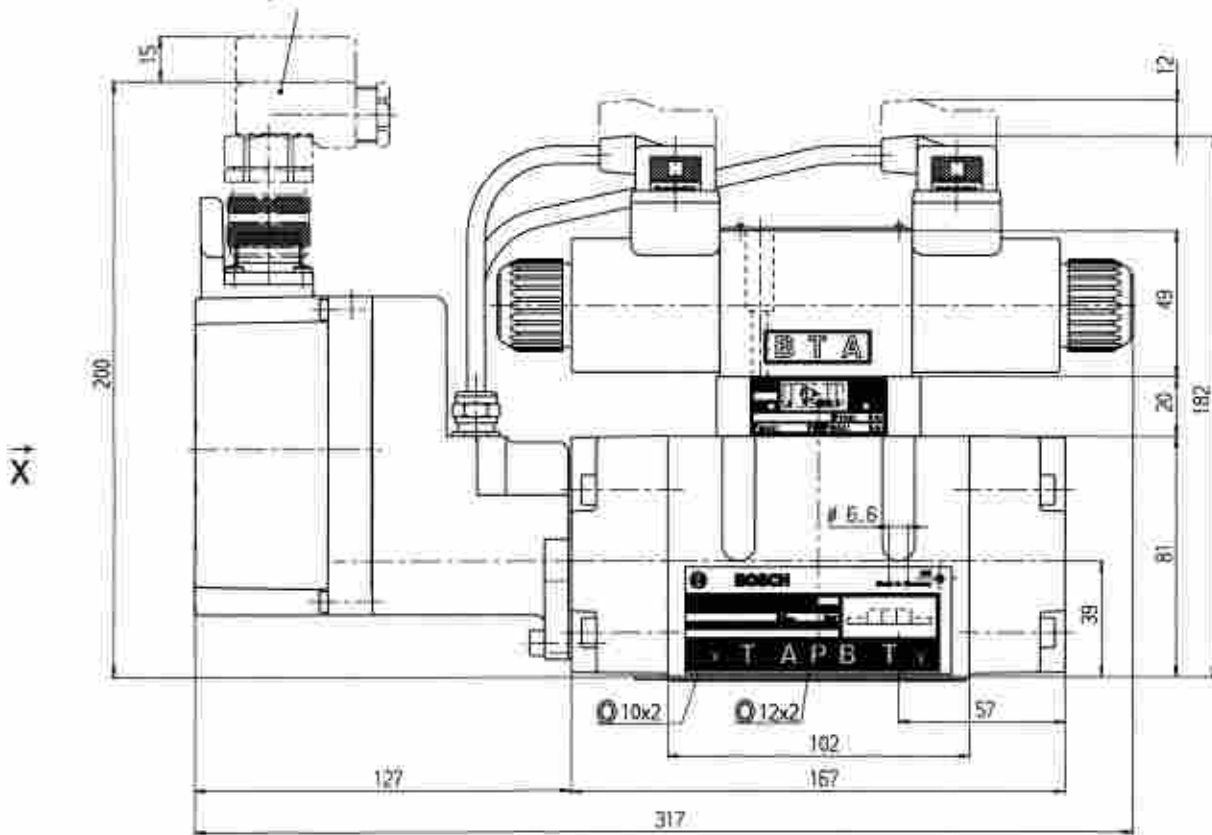

Set $\text{\textcircled{E}}$ 1817010280

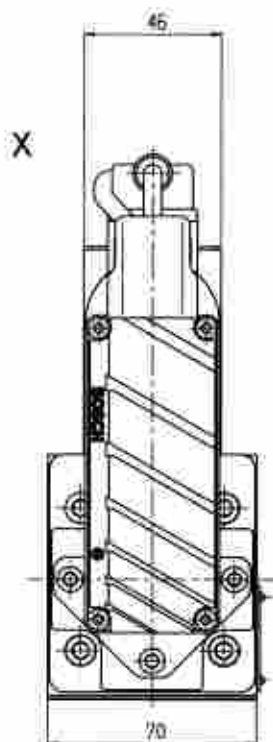

4x $\text{\textcircled{E}}$ M6x40 DIN 912 10.9
 $\text{\textcircled{E}}$ = 11⁺³ Nm
 $\text{\textcircled{E}}$ 2910151209



► Abmessungen des Anschluß-
 lochbildes NG 10 ISO 4401
 siehe Seite 101.

►► Dimensions of mounting hole
 configuration NG 10 ISO 4401
 see page 101.

►►► Cotes du plan de pose
 NG 10 ISO 4401
 voir page 101.

Abmessungen
Dimensions
Cotes d'encombrement

NG 16

1

nicht im Lieferumfang enthalten
 not included in scope of delivery
 non compris dans la fourniture:

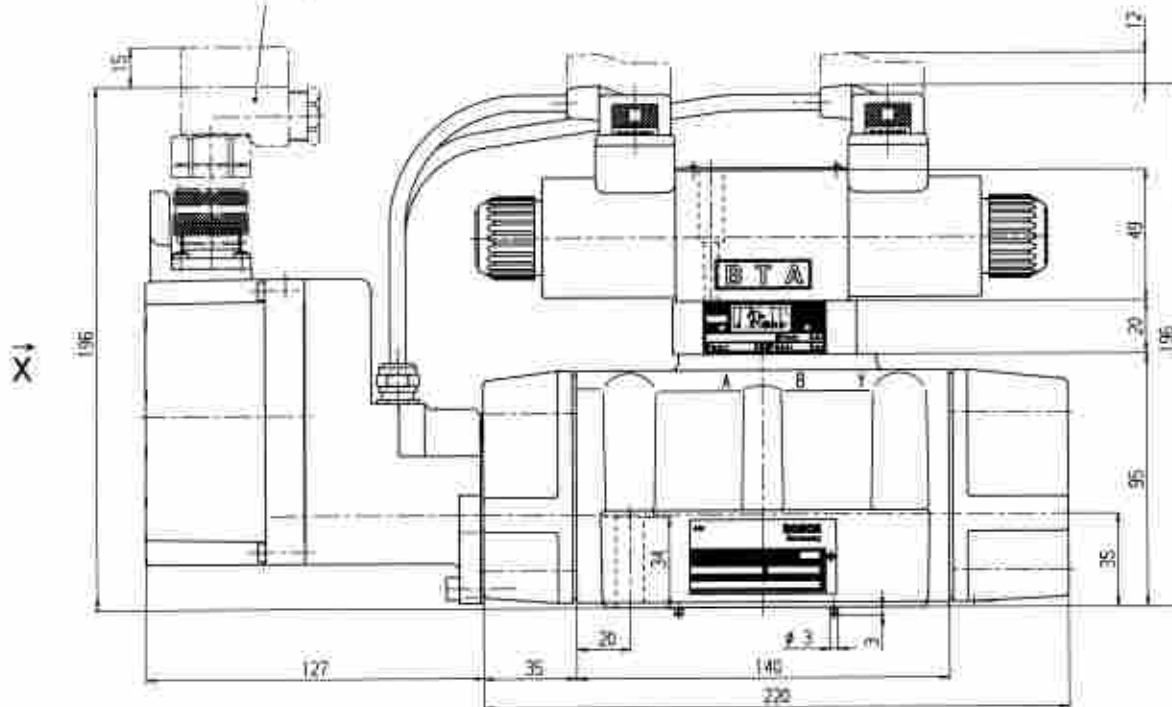

- Ø L₁, L₂, X, Y Ø 9 x 2
- Ø P, A, B, T Ø 23 x 2,5
- Ø Set Ø 1817 010 275

- 2 x M 6 x 45, DIN 912-10.9 11 Nm
- 4 x M 10 x 50, DIN 912-10.9 40 Nm

- M 6 x 45 Ⓢ 2910151211
- M 10 x 50 Ⓢ 2910151301

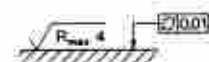
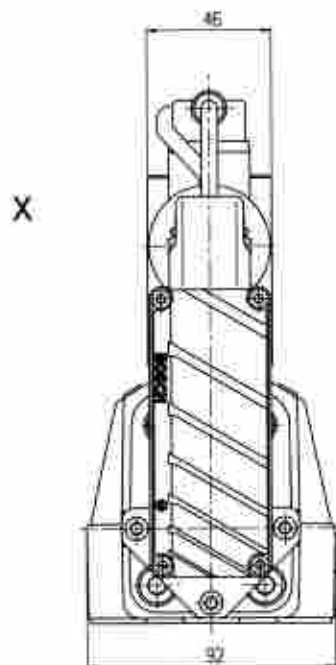

▶ Abmessungen des Anschlußlochbildes NG 16 ISO 4401 siehe Seite 101.

▶▶ Dimensions of mounting hole configuration NG 16 ISO 4401 see page 101.

▶▶▶ Cotes du plan de pose NG 16 ISO 4401 voir page 101.

1

**Abmessungen
 Dimensions
 Cotes d'encombrement**

NG 25 (32)

nicht im Lieferumfang enthalten
 not included in scope of delivery
 non compris dans la fourniture

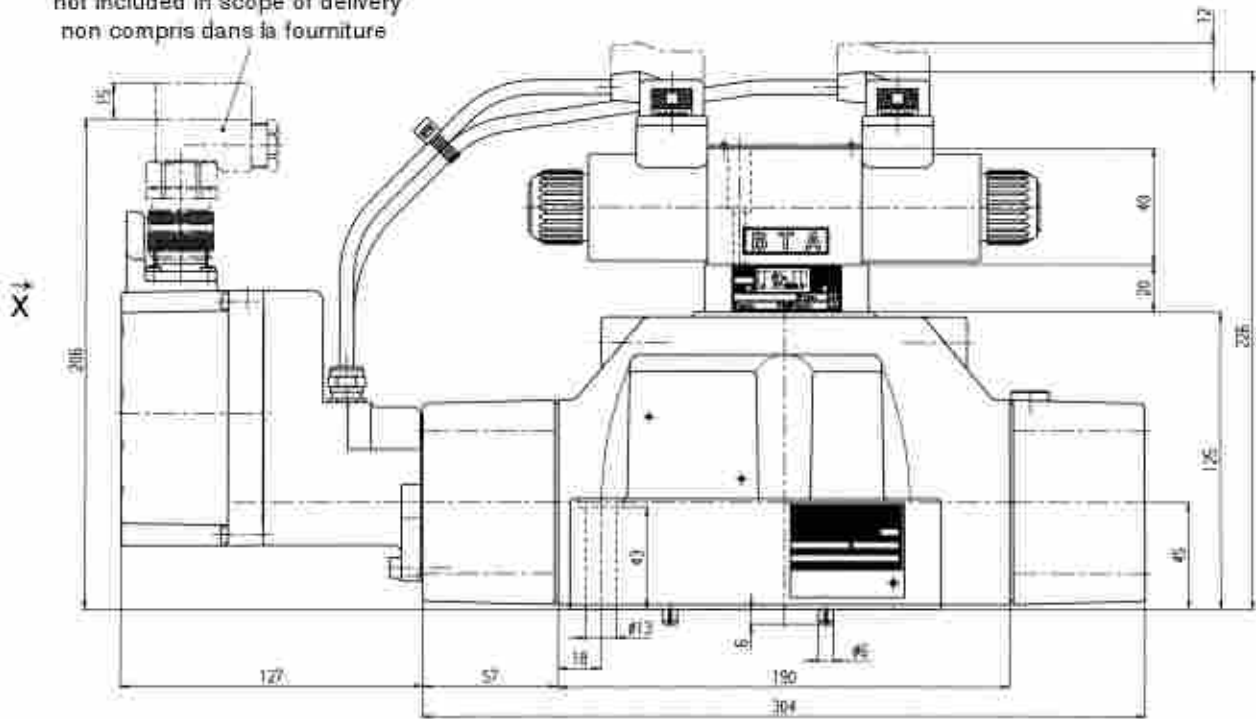

- Ø L₁, L₂, X, Y Ø 15 x 2,5
- Ø P, A, B, T Ø 34,6 x 2,82
- Ø Set Ø 1 817 010 344

6 x M 12 x 60, DIN 912-10.9
 = 90-30 Nm
 © 2910 151 354

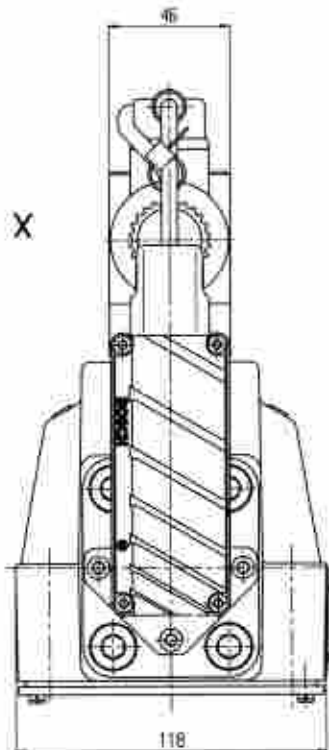

► Abmessungen des Anschluß-
 lochbildes NG 25 ISO 4401
 siehe Seite 102.
 Ø P, A, B, T max. 32 mm.

►► Dimensions of mounting hole
 configuration NG 25 ISO 4401
 see page 102.
 Ø P, A, B, T max. 32 mm.

►►► Cotes du plan de pose
 NG 25 ISO 4401
 voir page 102.
 Ø P, A, B, T max. 32 mm.

1 Adapter ISA Adapter Adaptateur



► **Funktion für DSP-Ventile**
 Interrupt Safety Adapter, Schutz-
 schaltung und Stecker-Anschluß
 für externe Magnietabschaltung
 (Not-Aus Kreis).

►► **Function of DSP valves**
 Interrupt Safety Adapter, safety circuit
 and connector adapter for external
 solenoid shut-off (emergency stop
 circuit).

►►► **Fonction pour valves DSP**
 Interrupt Safety Adapter, circuit de
 protection et fiche-raccord pour
 coupure externe de l'électro-aimant
 (circuit d'arrêt d'urgence).

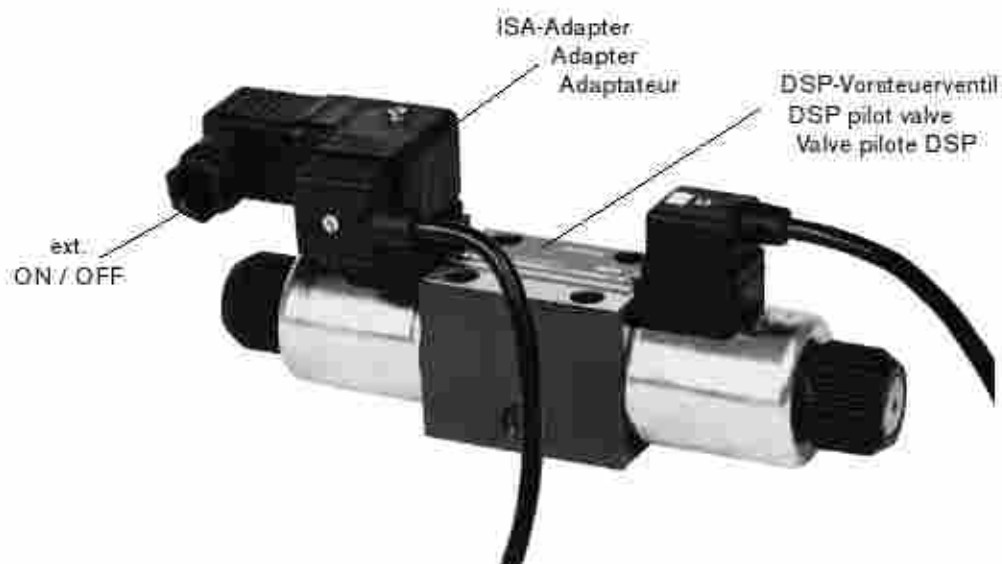

► **Hinweis:**
 Magnet „b“ regelt in der Hauptstufe
 das Symbol P-A/B-T.

►► **Note:**
 Solenoid "b" controls the symbol
 P-A/B-T in the main stage.

►►► **Remarque:**
 L'électro-aimant -b- régule le symbole
 P-A/B-T dans l'étage principal.

Symbild
 Symbol
 Symbole

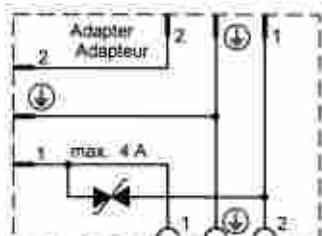

ISA-Adapter für Bosch-Regelmagnete bis 50 VA
 ISA adapter for Bosch control solenoids up to 50 VA
 Adaptateur ISA pour électro-aimants de régulation
 Bosch jusqu'à 50 VA

[kg]

€

0,07

1 834 484 245

► Schaltung mit ISA-Adapter

►► Circuit with ISA adapter

►►► Circuit avec adaptateur ISA

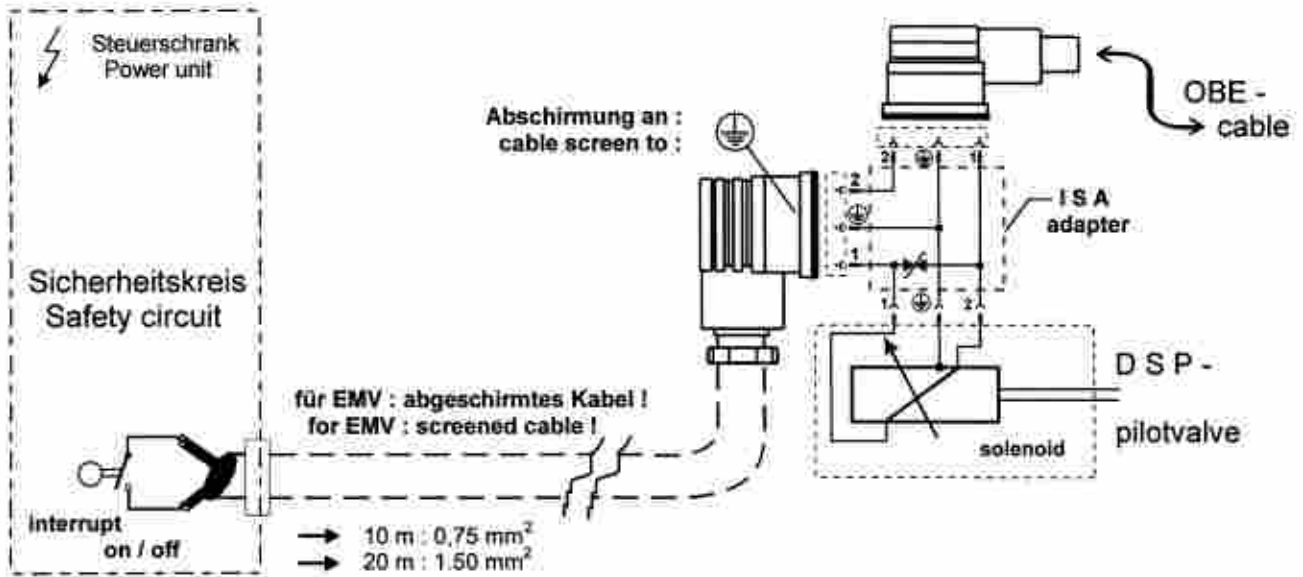

► **Hinweis:**
 Verantwortlich für die Installation nach EMV-Richtlinien, ist der Hersteller der Gesamtanlage.

►► **Note:**
 The manufacturer of the complete system is responsible for installation in accordance with EMC guidelines.

►►► **Remarque:**
 Le fabricant du système global est responsable de l'installation selon les directives relatives à la compatibilité électromagnétique.

► **Einbau-Beispiel:**
 ISA-Adapter in Magnet „b“ (ISO 4400).

►► **Installation example:**
 ISA adapter in solenoid „b“ (ISO 4400).

►►► **Exemple de montage:**
 Adaptateur ISA dans électro-aimant „b“ (ISO 4400).

