

"A" Series Variable Displacement Piston Pumps

www.khadamathydraulic.com
 Tell: 021-55882749
 Tell: 021-33488178
 Fax: 021-33488105



A37



A16



A56





A10



A1637

"A" Series Variable Displacement Piston Pumps

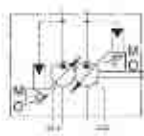
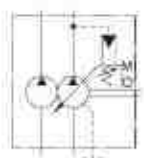
Pump Type	Graphic Symbols	Geometric Displacement:		Maximum Operating Pressure MPa (PSI)	Page
		cm ³ /rev	cu. in./rev		
Single Pumps					
		A10		21 (3050)	30
		A16		16 (2320)	
		A22		21 (3050)	
		A37		28 (4060)	
		A56		16 (2320)	
A70					
Double Pumps		Outboard Pump	A16 A37 A56	28 (4060)*	113
		Inboard Pump	A16 A37 A56 A70 A145 A220 A90		
Variable / Fixed Double Pumps		Outboard Pump	PV2R1 PV2R2	28 (4060)*	115
		Inboard Pump	A16 A37 A56 A70 A145 A220 A90		

* Various control types are available such as pressure compensator type. Refer to page 31 and 32.

* The maximum operating pressure for each double pump depends on its combination of pumps. Contact us for details.

Hydraulic Fluids

Hydraulic Fluids

Use petroleum based oils such as anti-wear type hydraulic oils or R & O (Rust and Oxidation inhibitor) type hydraulic oils equivalent to ISO VG-32 or 46. The recommended viscosity range is from 20 to 400 mm²/s (98 to 1800 SSU) and temperature range is from 0 to 60°C (32 to 140°F), both of which have to be satisfied for the use of the above hydraulic oils.

Control of Contamination

Due caution must be paid to maintaining control over contamination of the operating oil which can otherwise lead to breakdowns and shorten the life of the unit.

Please maintain the degree of contamination within NAS Grade 10.

The suction port must be equipped with at least a 100 μm (150 mesh) reservoir type filter and the return line must have a line type filter of under 10 μm.

Instructions

Mounting

When installing the pump the filling port should be positioned upwards.

Alignment of Shaft

Employ a flexible coupling whenever possible, and avoid any stress from bending or thrust.

Maximum permissible misalignment is less than 0.1 mm (.004 inches) TIR and maximum permissible misangular is less than 0.2°.

Suction Pressure

Permissible suction pressure at inlet port of the pump is between -16.7 and +50 kPa (5 in.Hg Vacuum and 7 PSIG).

For piping to the suction port, use the pipes of the same diameter as that of the specified pipe flange to be used. Make sure that the height of the pump suction port is within one metre (3.3 ft) from the oil level in the reservoir.

Hints on Piping

When using steel pipes for the suction or discharge ports, excessive load from the piping to the pump generates excessive noise.

Whenever there is fear of excessive load, please use rubber hoses.

Suction Piping

In case the pump is installed above the oil level, the suction piping and suction line filter should be located lower than the pump position to prevent air in the suction line.

When using steel pipes for the suction or discharge ports, excessive load from the piping to the pump generates excessive noise.

Whenever there is fear of excessive load, please use rubber hoses.

Drain Piping

Install drain piping according to the chart and ensure that pressure within the pump housing should be maintained at a normal pressure of less than 0.1 MPa (14.5 PSI) and surge pressure of less than 0.5 MPa (72.5 PSI).

Length of piping should be less than 1 m (3.3 ft.), and the pipe end should be submerged in oil.

[Recommended Drain Piping Size]

Model	Fitting Size		Inside Dia. of Pipe
	Japanese Std. "JIS" & European Design Std.	N.American Design Std.	
A10	3/8 [Inside Dia. 8.5 mm (.33 in.) or more]	SAE #6	10 mm (.39 in.)
A16, A22	3/8 [Inside Dia. 8.5 mm (.33 in.) or more]	SAE #8	
A37	1/2 [Inside Dia. 10 mm (.47 in.) or more]	SAE #10	12 mm (.47 in.)
A56, A70, A90, A145	3/4 [Inside Dia. 16 mm (.63 in.) or more]	SAE #12	19 mm (.75 in.)

Bleeding Air

It may be necessary to bleed air from pump case and outlet line to remove causes of vibration. An air bleed valve (Model Number ST1004- ϕ -10 ϕ , Page 820) is recommended for this purpose.



Starting

Before first starting, fill pump case with clean operating oil via the filling port.

In order to avoid air blockage when first starting, adjust the control valves so that the discharged oil from the pump is returned direct to the reservoir or the actuator moves in a free load.

[Volume of Pre-fill Oil Required]

Model	Volume cm ³ (cu.in.)
A10	370 (22.6)
A16/A22	600 (36.6)
A37/A56	1200 (73.2)
A70	2100 (128)
A90	2500 (153)
A145	3300 (201)

Setting Discharge Pressure and Delivery

At the time of shipment, the unit has been preset to maximum delivery and minimum discharge pressure.

Adjust the preset delivery and pressure to meet your system requirements.

Adjustment of Discharge Pressure

Turning the adjustment screw clockwise, increases pressure.

[Volume adjusted by each full turn of the pressure adjustment screw]

Model Numbers	Adjustment Volume MPa (PSI)
A10-FR01B	2.9 (420)
A10-FR01C/H	5.4 (780)
A16/A22/A37/A56- \ast -R-01-B	3.5 (510)
A16/A22/A37/A56- \ast -R-01-C	6.5 (940)
A16/A37/A56- \ast -R-01-H	7.9 (1150)
A70/A90/A145- \ast -R01B	2.3 (330)
A70/A90/A145- \ast -R01C	3.2 (460)
A70/A90/A145- \ast -R01H	4.0 (580)
A70/A90/A145- \ast -R01K	4.7 (680)

Adjustment of Delivery

Turning the flow adjustment screw clockwise, decreases delivery.

[The minimum adjustable flow and adjustable volume of each full turn of the delivery adjustment screw]

Model Numbers	Adjustable volume with each full turn of the adjustment screw cm ³ /rev (cu.in./rev)	Minimum adjustment flow cm ³ /rev (cu.in./rev)
A10	1.1 (.067)	2.0 (.122)
A16	1.4 (.085)	4.0 (.244)
A22	2.0 (.122)	6.0 (.366)
A37	2.9 (.177)	10 (.610)
A56	3.9 (.238)	12 (.732)
A70	4.4 (.268)	30 (1.83)
A90	4.8 (.293)	56 (3.42)
A145	7.7 (.430)	83 (5.06)

"A" Series Variable Displacement Piston Pumps

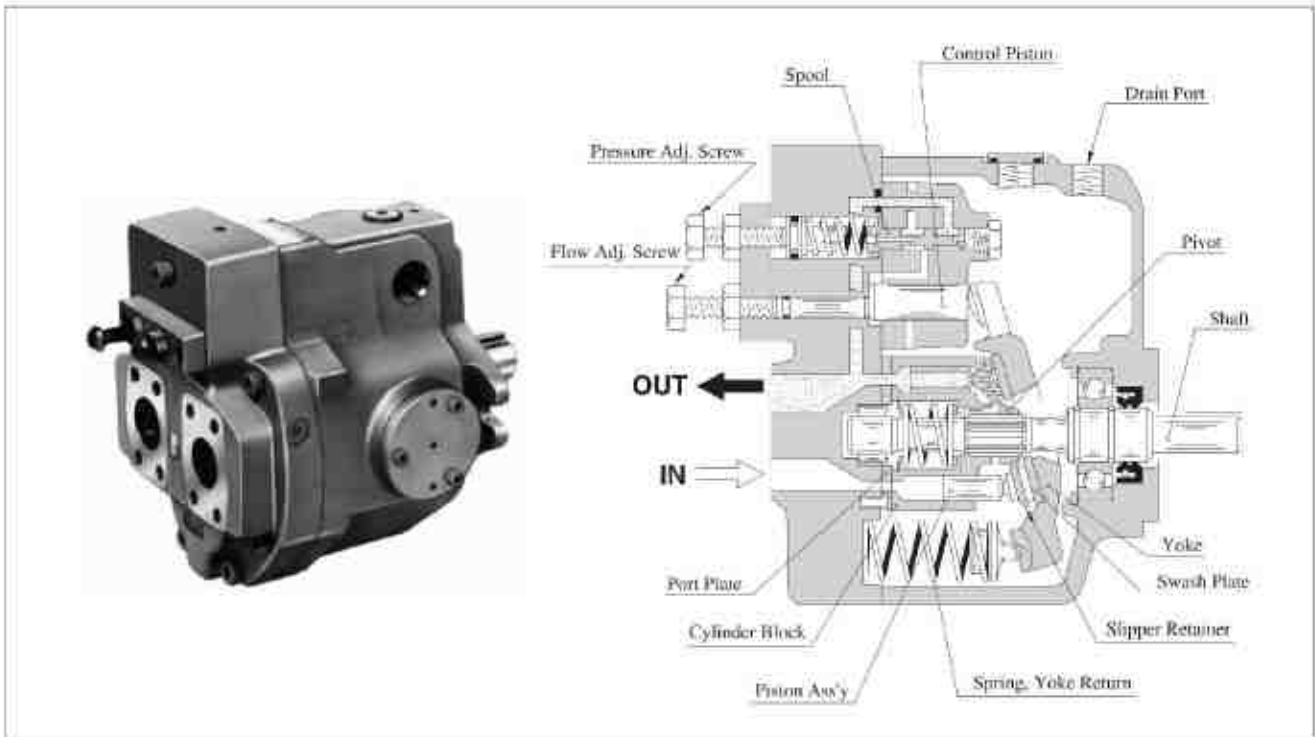

■ Features

● High efficiency

Under the conditions of pressure 16 MPa (2320 PSI) and speed 1800 r/min, the volumetric efficiency is over 98% and the overall efficiency is over 90%.

● Low noise level

In the "A16" pump, the noise level is as low as 57.3 dB(A) [at the full cut-off pressure 21 MPa (3050 PSI) with speed 1500 r/min one metre (3.3 ft.) horizontally away from pump head cover.]

"A16" type performance characteristics

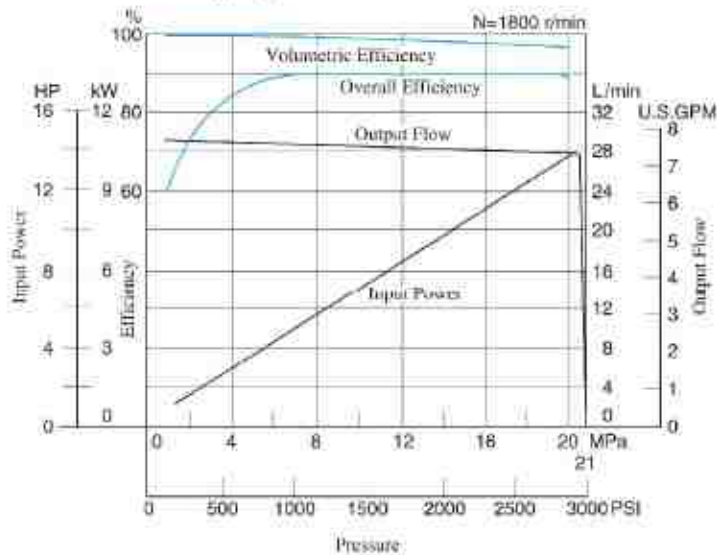

"A16" type noise level characteristics

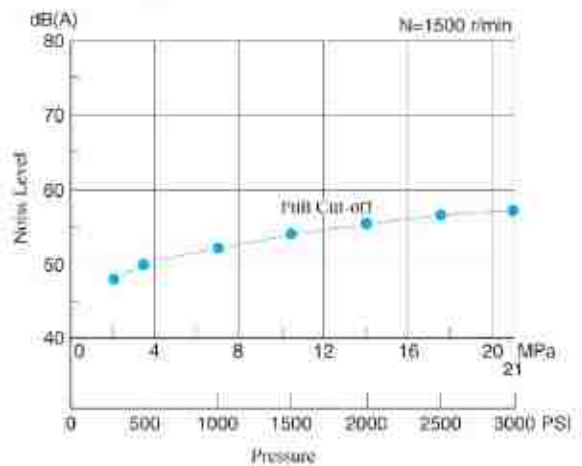

● Accomplishment of energy-saving

Because the overall efficiency is high and the cut-off characteristics is sharp, thus the input power may be saved.

● Low heat generation



Because of small power loss, it is possible to reduce the rise in oil temperature. Accordingly, capacity of a reservoir can be reduced.



Control Type

Control Type	Graphic Symbols	Performance Characteristics	Explanation	Page
"01" Pressure Compensator Type			When the system pressure increases and comes close to the preset cut-off pressure, the pump flow decreases automatically while maintaining the set pressure as it is.	33
"02" Solenoid-two Pressure Control Type			This type of control is ideal for an application where the output power of the actuator has to be controlled in two different load pressures while keeping the actuator speed nearly constant.	55
"03" Pressure Compensator with Unloading Type			It is suitable for a situation where a long unloading time is required and heat generation and noise have to be kept at their lowest levels. <ul style="list-style-type: none"> The pump can be used in combination with the multistage pressure control valve. 	63
"04" Proportional Electro-Hydraulic Load Sensing Type			This is an energy-saving type control which regulates the pump flow and load pressure to be at absolute minimum necessary level to operate the actuator. Pump flow rate and cut-off pressure are controlled proportional to the input current to the control device on the pump and the input current is regulated by the specific amplifier.	64
"04E" Electro-Hydraulic Proportional Pressure & Flow Control Type			This type of control has the pressure sensor and tilt angle sensor in the pump. The pump is used with the external amplifier (amplifier is integrated into pump in case of "04EH"). Flow and pressure can be controlled in proportion to input voltage by only one control valve.	74
"04EH" Electro-Hydraulic Proportional Pressure & Flow Control Type (OBE Type)			The features has been greatly improved by electrical feedback of swash plate tilt angle correspond to flow rate and load pressure to control valve. <ul style="list-style-type: none"> Linearity of input characteristics is excellent and easy to set. Hysteresis is lower, repeatability and reproducibility are fine. 	86
"05" Two-Pressure Two-Flow Control Type by System Pres.			This type of control is suitable for an application like "Presses" where the changeover from rapid advance to feed is required just when the pressing (pressurizing) starts.	—
"06" Two-Pressure Two-Flow Control Type by Solenoid Valve			This pump control is suitable for machining found on machine tool, where machining starts after the changeover from rapid advance, to feed has been made.	—

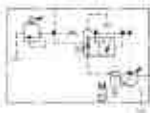
Control Type

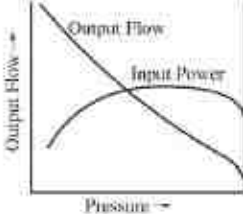
Control Type	Graphic Symbols	Performance Characteristics	Explanation	Page
"07" Pilot Pressure Control Type Pressure Compensator			The pump is used in combination with the pilot relief valve or multistage pressure control valve. By controlling the pilot pressure, the full cut-off pressure can be remote-controlled according to your requirements.	96
"09" Constant Power Control Type			<ul style="list-style-type: none"> • Pump input power can be controlled in accordance with the motor output. • When the discharge pressure rise, the output flow decreases corresponding to the preset input power. • The pump can act for function of two pumps, low-pressure large-flow and high-pressure small-flow. Therefore, the motor capacity can be reduced. 	105

★ Control type "05" and "06" are not shown in this catalogue. Contact us for the details.

Availability of Control Type

Mark "○" in the table below refers to standard model.

Model Numbers	Geometric Displacement cm ³ /rev (cu.in./rev)	Control Type										
		01	02	03	04	04E	04EH	05	06	07	09	
A10	10.0 (.610)	○									○	
A16	15.8 (.964)	○	○	○	○	○	○	○	○	○	○	○
A22	22.2 (1.355)	○	○	○	○	○	○		○	○		
A37	36.9 (2.25)	○	○	○	○	○	○	○	○	○	○	○
A56	56.2 (3.43)	○	○	○	○	○	○	○	○	○	○	○
A70	70.0 (4.27)	○	○	○	○	○	○		○	○	○	○
A90	91.0 (5.55)	○	○	○	○	○	○		○	○		
A145	145 (8.85)	○	○	○	○	○	○		○	○	○	



"A" Series Variable Displacement Piston Pumps – Single Pump, Pressure Compensator Type



Graphic Symbol

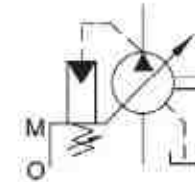

Specifications

Model Numbers	Geometric Displacement cm ³ /rev (cu. in./rev)	Minimum Adj. Flow cm ³ /rev (cu. in./rev)	Operating Pressure MPa (PSI)		Shaft Speed Range r/min		Approx. Mass kg (lbs.)	
			Rated ¹⁾	Intermittent ²⁾	Max.	Min.	Flange Mtg.	Foot Mtg.
A10-FR01B-12*	10.0 (.610)	2 (.122)	16 (2320)	21 (3050)	1800	600	3.1 (11.2)	—
A10-FR01C/B-12*							8.5 (18.7)	
A16-#-R-01-#-#-K-32*	15.8 (.964)	4 (.244)	16 (2320)	21 (3050)	1800	600	16.5 (36.4)	18.7 (41.2)
A22-#-R-01-#-#-K-32*	22.2 (1.355)	6 (.366)	16 (2320)	16 (2320)	1800	600	16.5 (36.4)	18.7 (41.2)
A37-#-R-01-#-#-K-32*	36.9 (2.25)	10 (.610)	16 (2320)	21 (3050)	1800	600	28.0 (61.7)	32.3 (71.2)
A56-#-R-01-#-#-K-32*	56.2 (3.43)	12 (.732)	16 (2320)	21 (3050)	1800	600	35.0 (77.2)	39.3 (86.7)
A70-#R01-#S-60*	70.0 (4.27)	30 (1.83)	25 (3630)	28 (4060)	1800	600	58.5 (129)	70.5 (155)
A90-#R01-#S-60*	91.0 (5.55)	56 (3.42)	25 (3630)	28 (4060)	1800	600	72.5 (160)	93 (205)
A145-#R01-#S-60*	145 (8.85)	83 (5.06)	25 (3630)	28 (4060)	1800	600	92.5 (204)	117.5 (259)

- ★1. Whenever setting pressure, make sure the full cut-off pressure never exceeds the maximum intermittent pressure.
- ★2. Care should be taken in cases of used at a higher pressure than the rated pressure, because operating terms may be restricted. For example, if used as per maximum illustrated operating conditions, intermittent time at maximum flow is restricted to under 1/5 of one cycle time and under six seconds simultaneously. Conditions may vary according to the actual working pressure and delivery (inclination angle of the swash plate). Consult factory or Yuken sales representative for further information.
- ★3. The table above shows specifications for using petroleum based oils. Pumps (customized design) for special fluids are also available. Their operating pressure and maximum shaft speed however differ from the values in the table above depending on the fluid type. Range of operating temperature and viscosities may differ from those of petroleum based oils due to their characteristics.

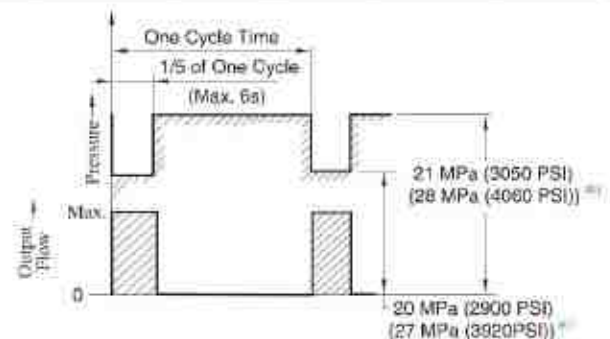

*1. Applicable only for "A70/90/145"

Specifications and Design numbers for Special Fluids

Type of Fluids	Pump Series	Operating Pressure MPa (PSI)		Allowable Maximum Shaft Speed r/min		Temperature Range °C (°F)	Viscosity Range mm ² /s (SSU)	Design Numbers for Special Fluid (Occasion of Japanese Std. "JIS") ³⁾
		Rated	Intermittent	Rated	Max.			
Water-Glycols	A16 – A56	14(2030)	16(2320) (14(2030)) ¹⁾	1200	(1800) ²⁾	0 - 50 (32 - 104)	20 - 200(98 - 927)	3230
	A70 – A145	21(3050)	21(3050)					6030
Phosphate Ester Type	A16 – A56	14(2030)	16(2320) (14(2030)) ¹⁾	1200	(1800) ²⁾	0 - 60 (32 - 140)	20 - 200(98 - 927)	3206
	A70 – A145	21(3050)	21(3050)					6006
Polyol Ester Type	A16 – A56	16(2320)	16(2320)	1800	1800	0 - 60 (32 - 140)	20 - 200(98 - 927)	32450
	A70 – A145	21(3050)	21(3050)					60450

- ★1. The figures in brackets are for A22 type.
- ★2. As the specific gravities of water-glycol fluids and phosphate ester type fluids are higher than one, an overhead reservoir is required when pumps are operated at 1500 r/min or more.
- ★3. For the design numbers of pumps for European Design and North American Design Standards, please contact us.

Model Number Designation

A16	-F	-R	-01	-B	-S	-K	-32	*
Series Number	Mounting	Direction of Rotation	Control Type	Pres. Adj. Range (MPa (PSI))	Port Position	Shaft Extension	Design Number	Design Std.
A16 (15.8 cm ³ /rev)			01: Pressure Compensator Type	B: 1.2 - 7 (170 - 1020) C: 1.2 - 16 (170 - 2320) H: 1.2 - 21 (170 - 3050)	None: Axial Port S: Side Port	K: Keyed Shaft	32	Refer to ^{*1}
A22 (22.2 cm ³ /rev)	F: Flange Mtg.	Viewed from Shaft End		B: 1.2 - 7 (170 - 1020) C: 1.2 - 16 (170 - 2320)			32	
A37 (36.9 cm ³ /rev)	L: Foot Mtg.	R: Clockwise (Normal)		B: 1.2 - 7 (170 - 1020) C: 1.2 - 16 (170 - 2320) H: 1.2 - 21 (170 - 3050)			32	
A56 (56.2 cm ³ /rev)				32				

A70	-F	R	01	B	S	-60	*
Series Number	Mounting	Direction of Rotation	Control Type	Pres. Adj. Range (MPa (PSI))	Port Position	Design Number	Design Std.
A10 (10.0 cm ³ /rev)	F: Flange Mtg. ^{*2}		01: Pressure Compensator Type	B: 1.2 - 7 (170 - 1020) ^{*3} C: 2.0 - 16 (290 - 2320) H: 2.0 - 21 (290 - 3050)	—	12	Refer to ^{*1}
A70 (70.0 cm ³ /rev)	F: Flange Mtg.	Viewed from Shaft End		B: 1.2 - 7 (170 - 1020) C: 1.5 - 16 (220 - 2320) H: 1.8 - 21 (260 - 3050) K: 2.0 - 28 (290 - 4060)	S: Side Port	60	
A90 (91.0 cm ³ /rev)	L: Foot Mtg.	R: Clockwise (Normal)		60			
A145 (145 cm ³ /rev)				60			

★1. Available to supply pump with anti-clockwise rotation. Consult Yuken for details.

★2. Design Standards: None Japanese Standard "JIS"
 80 European Design Standard
 950 N. American Design Standard

★3. When A10 pump is used as the foot Mtg., order the Mtg. Bracket kit shown below separately. Refer to page 24 for dimensions of the Mtg. bracket.

Note: The mounting bracket kit consists of a mounting bracket, two hex bolts and two plain washer.

Mtg. Bracket Kit Numbers	Approx. Mass (kg (lbs.))
LP-1A-10	2.2 (4.9)

★4. The pressure adjustment range "B" is not available to the European Design Standard and the N. American Design Standard of "A10".

Pipe Flange Kits

Pipe flange kits are available. When ordering, specify the kit number from the table below.

Pump Model Numbers	Name of Port	Pipe Flange Kit Numbers						
		Threaded Connection			Socket Welding ^{*1}		Butt Welding	
		Japanese Std. "JIS"	European Design Std.	N. American Design Std.	Japanese Std. "JIS" European Design Std.	N. American Design Std.	Japanese Std. "JIS" European Design Std.	N. American Design Std.
A16-#R-01	Suction	F5-06-A-10	F5-06-A-1080	—	F5-06-B-10	F5-06-B-1090	F5-06-C-10	F5-06-C-1090
A22-#R-01	Discharge	F5-06-A-10	F5-06-A-1080	—	F5-06-B-10	F5-06-B-1090	F5-06-C-10	F5-06-C-1090
A37-#R-01	Suction	F5-10-A-10	F5-10-A-1080	—	F5-10-B-10	F5-10-B-1090	F5-10-C-10	F5-10-C-1090
A56-#R-01	Discharge	F5-10-A-10	F5-10-A-1080	—	F5-10-B-10	F5-10-B-1090	F5-10-C-10	F5-10-C-1090
A70-#R01	Suction	F5-12-A-10	F5-12-A-1080	—	F5-12-B-10	F5-12-B-1090	F5-12-C-10	F5-12-C-1090
	Discharge	F5-08-A-10	F5-08-A-1080	—	F5-08-B-10	F5-08-B-1090	F5-08-C-10	F5-08-C-1090
A90-#R01	Suction	F5-16-A-10	F5-16-A-1080	—	F5-16-B-10	F5-16-B-1090	F5-16-C-10	F5-16-C-1090
A145-#R01	Discharge	F5-10-A-10	F5-10-A-1080	—	F5-10-B-10	F5-10-B-1090	F5-10-C-10	F5-10-C-1090

★1. In case of using socket welding flanges, there is a case where the operating pressure should be set lower than the normal because of strength of the flanges. Therefore, please pay cautious attention to the operating pressure when the socket welding flanges are used.

★2. As dimensions of the pipe flange mounting surface are conformed to SAE 4 Bolt Split Flange (Standard Pressure Series), pipe flanges conforming to the SAE Standards can be used.

★ Details of the pipe flange kits are shown on page 824.



Response Characteristics Change in Accordance with Circuits and Operating Conditions.

■ Test Circuit and Conditions

● Circuit

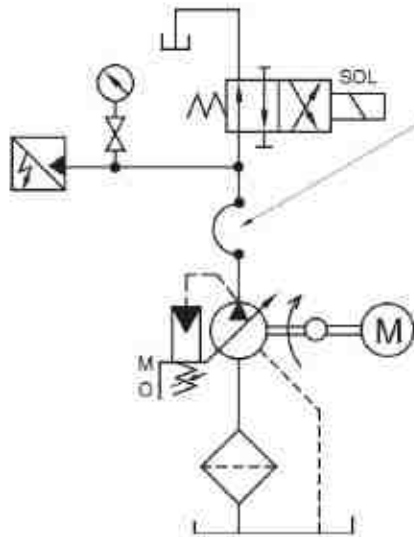

● Conditions

- Drive Speed : 1500 r/min
- Hydraulic Fluid : ISO VG32 oil
- Oil Temperature : A10-A56: 50 °C (122 °F) [Viscosity 20 mm²/s (100 SSU)]
- A70-A145: 40 °C (104 °F) [Viscosity 32 mm²/s (150 SSU)]

High Pressure Rubber Hose

Model	Ruber Hose Size
A10	1/2" × 800 mm (2.6 ft.)
A16 A22	3/4" × 700 mm (2.3 ft.)
A37 A56	3/4" × 2000 mm (6.6 ft.)
A70	3/4" × 3500 mm (11.5 ft.)
A90 A145	3/4" × 3000 mm (9.8 ft.) + 1-1/4" × 2000 mm (6.6 ft.)

■ Result of Measurement

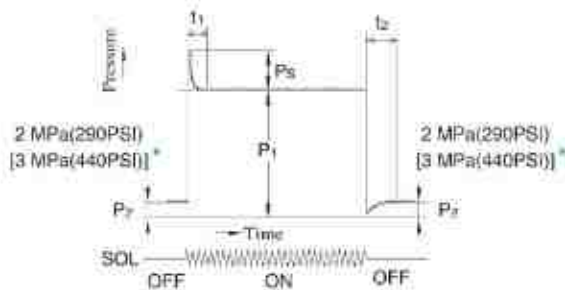

★ Applicable only for "A90/A145"

Model	Full Cut-off Pressure P ₁ MPa (PSI)	Response Time ms		Overshoot Pressure P ₂ MPa (PSI)
		t ₁	t ₂	
A10	21 (3050)	100	75	2.6 (380)
A16	16 (2320)	38*	59*	3.6 (520)
A22	16 (2320)	30*	72*	5.9 (860)
A37	16 (2320)	40*	78*	7.8 (1130)
A56	16 (2320)	38*	88*	7.6 (1100)
A70	25 (3630)	80	100	7.8 (1130)
A90	25 (3630)	90	110	7.9 (1150)
A145	25 (3630)	100	150	8.8 (1280)

* Response time except A10, A70, A90 and A145 is measured Yoke travel.

Typical Performance Characteristics of Type "A10" at Viscosity 20 mm²/s (100 SSU) [ISO VG32 Oils, 50°C (122°F)]

Performance Characteristic Curve

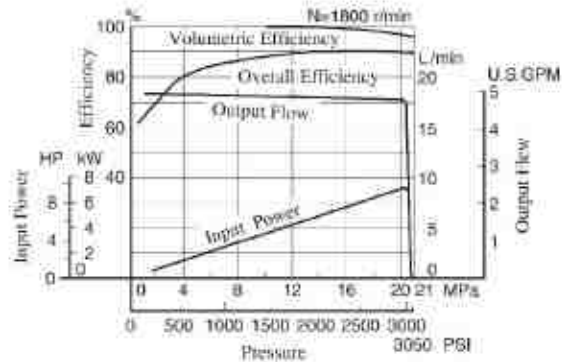
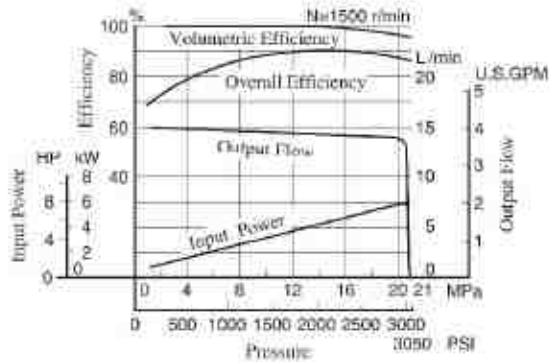

Input Power

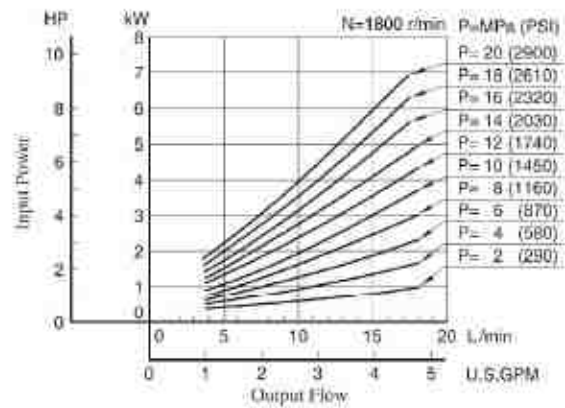
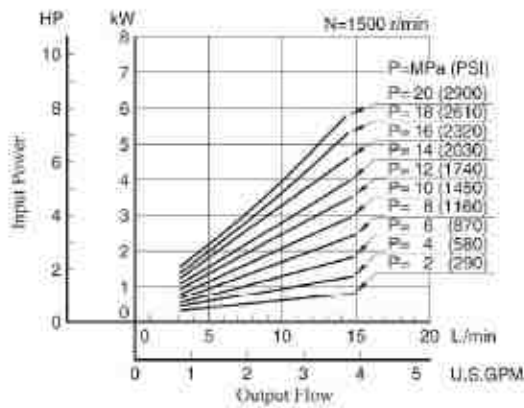

Full Cut-off Power

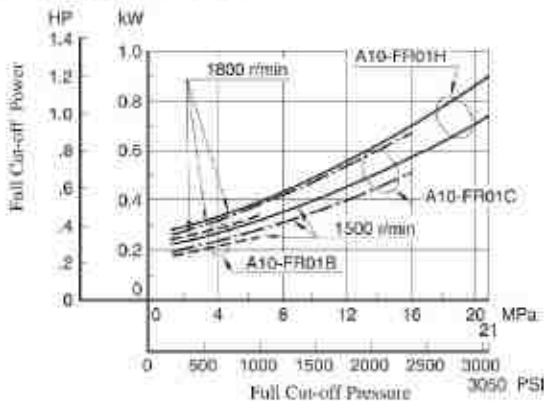

Drain

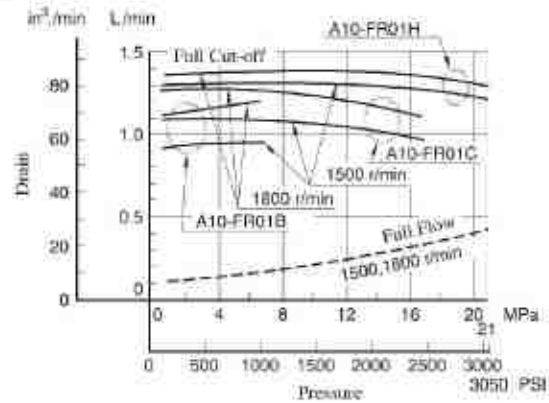

Noise Level (One metre (3.3 ft.) horizontally away from pump head cover)

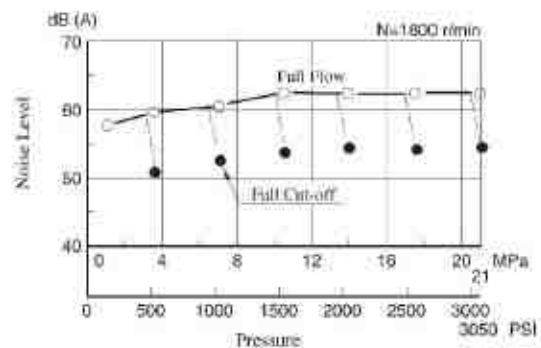
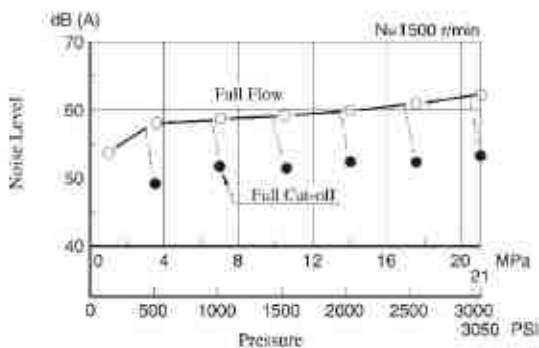



Typical Performance Characteristics of Type "A16" at Viscosity 20 mm²/s (100 SSU) [ISO VG32 Oils, 50°C (122°F)]

■ Performance Characteristic Curve

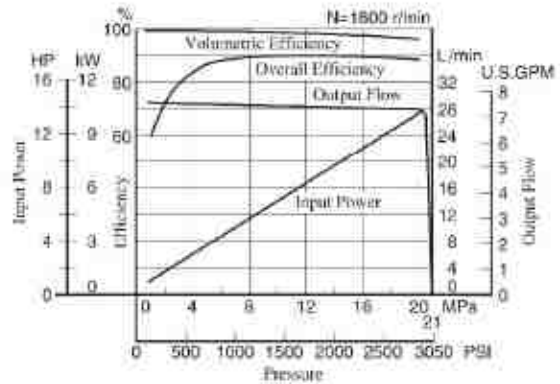
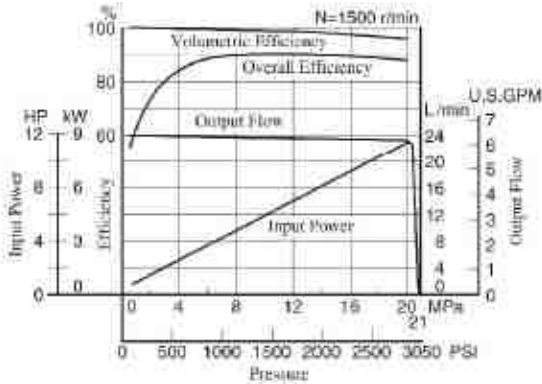

■ Input Power

Example: At a pressure of under 10 MPa (1450 PSI), a flow 20 L/min (5.3 U.S.GPM), and rotation 1500 r/min, the axial input becomes about 3.7 kW (5 HP) as shown the dotted line in the graph.

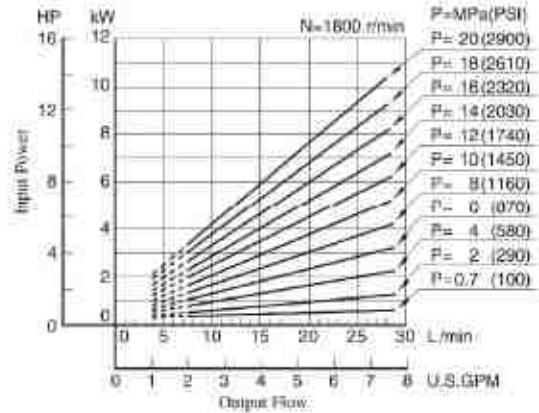
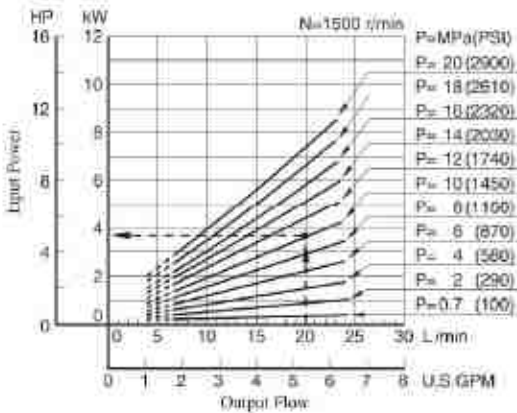

■ Full Cut-off Power

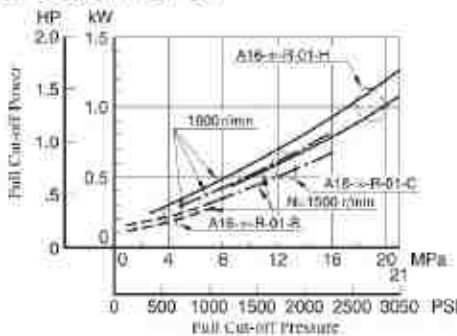

■ Drain

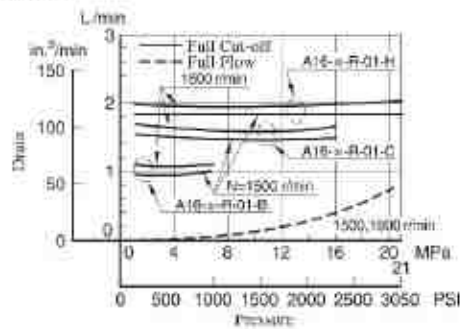

■ Noise Level [One metre (3.3 ft.) horizontally away from pump head cover]

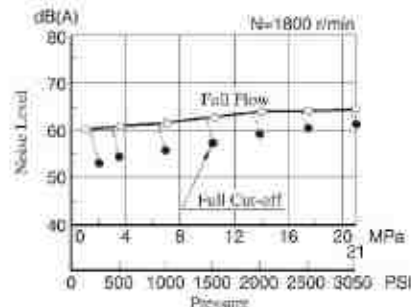
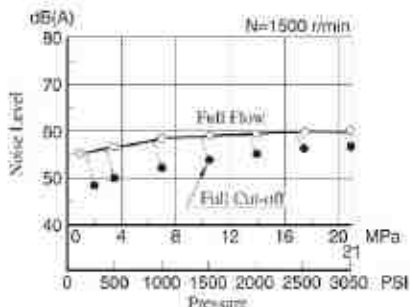

Typical Performance Characteristics of Type "A22" at Viscosity 20 mm²/s (100 SSU) [ISO VG32 Oils, 50°C (122°F)]

Performance Characteristic Curve

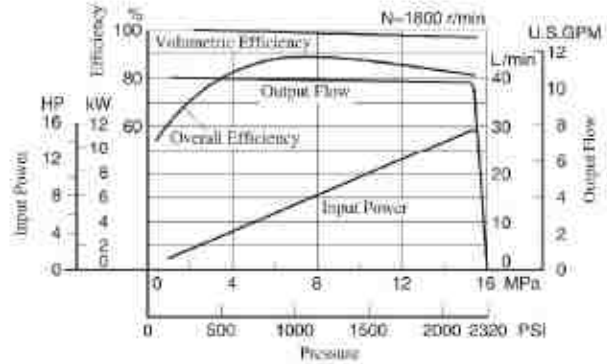
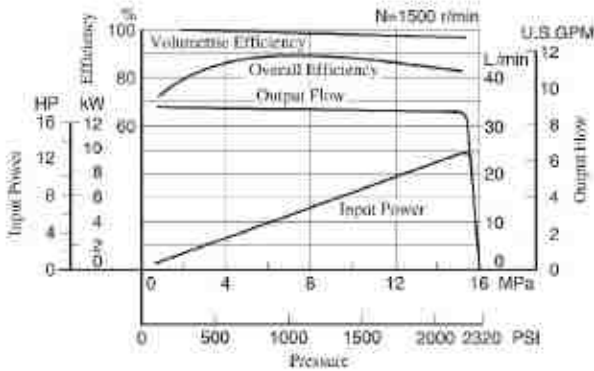

Input Power

Example: At a pressure of under 10 MPa (1450 PSI), a flow 30 L/min (7.9 U.S.GPM), and rotation 1500 r/min, the axial input becomes about 5.4 kW (7.2 HP) as shown the dotted line in the graph.

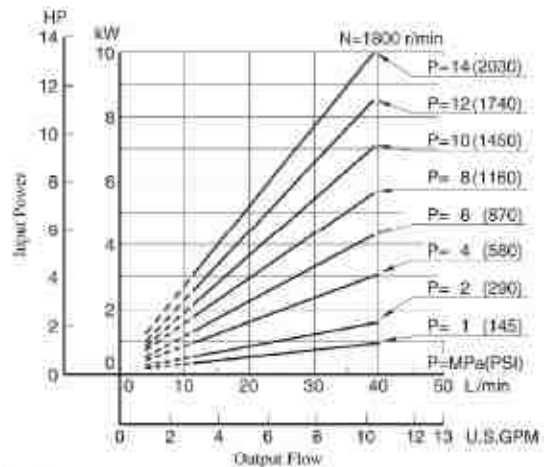
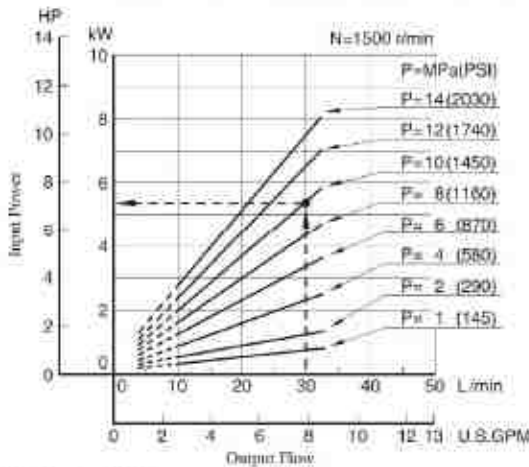

Full Cut-off Power

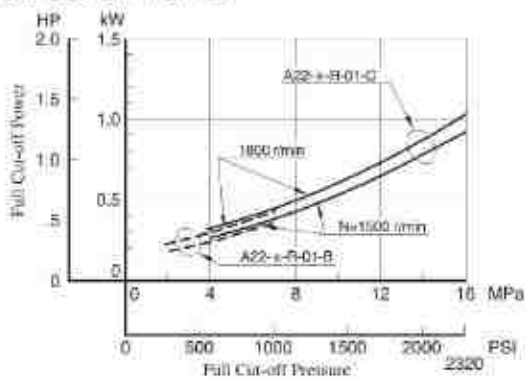

Drain

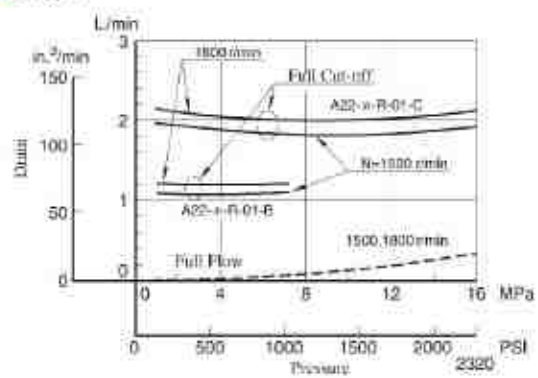

Noise Level [One metre (3.3 ft.) horizontally away from pump head cover]

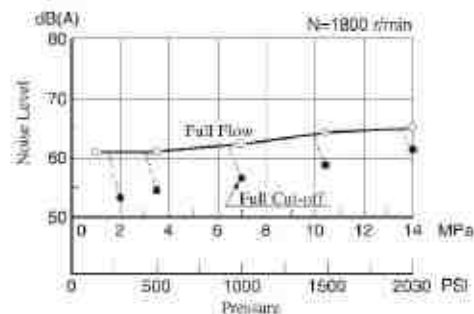
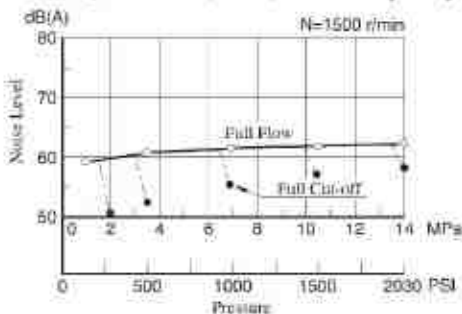



Typical Performance Characteristics of Type "A37" at Viscosity 20 mm²/s (100 SSU) [ISO VG32 Oils, 50°C (122°F)]

Performance Characteristic Curve

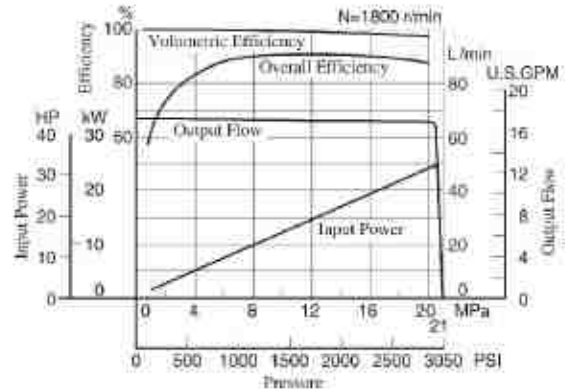
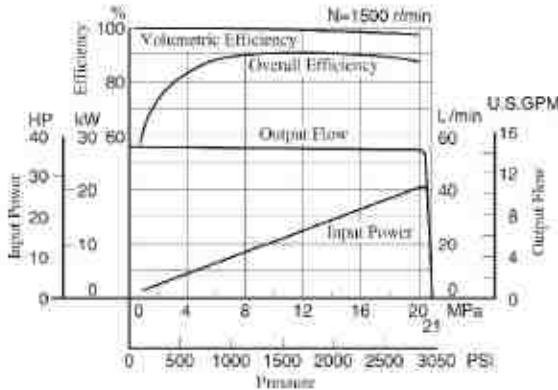

Input Power

Example: At a pressure of under 16 MPa (2320 PSI), a flow 45 L/min (11.9 U.S.GPM), and rotation 1500 r/min, the axial input becomes about 12.6 kW (16.9 HP) as shown the dotted line in the graph.

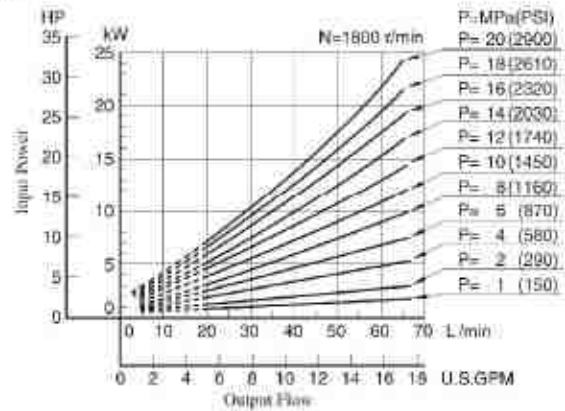
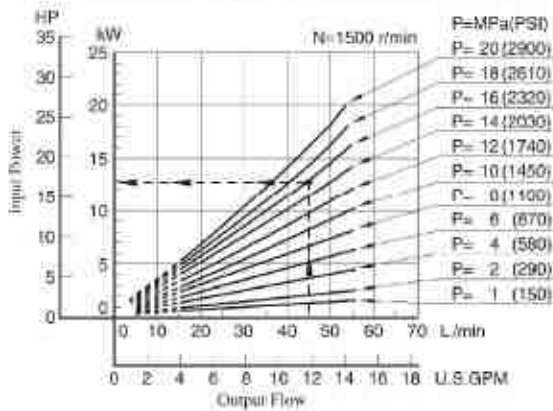

Full Cut-off Power

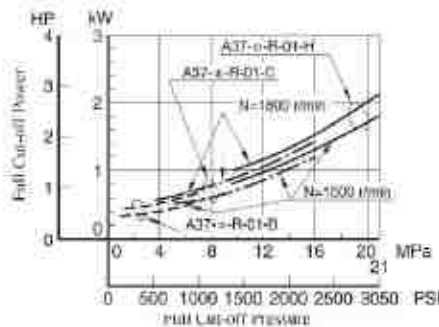

Drain

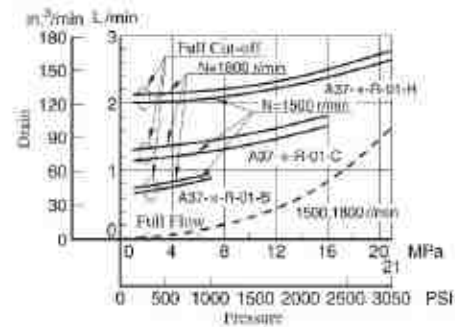

Noise Level [One metre (3.3 ft.) horizontally away from pump head cover]

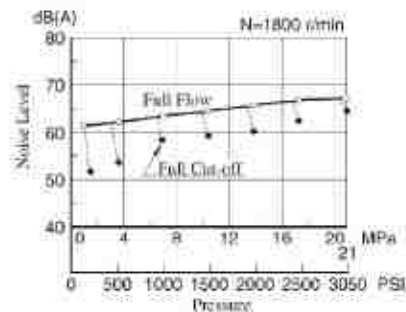
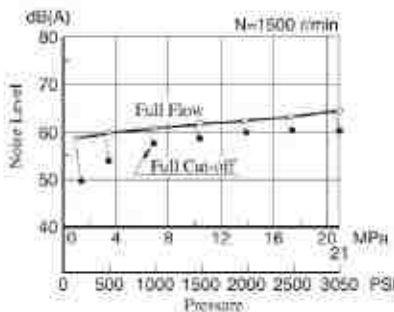

Typical Performance Characteristics of Type "A56" at Viscosity 20 mm²/s (100 SSU) [ISO VG32 Oils, 50°C (122°F)]

Performance Characteristic Curve

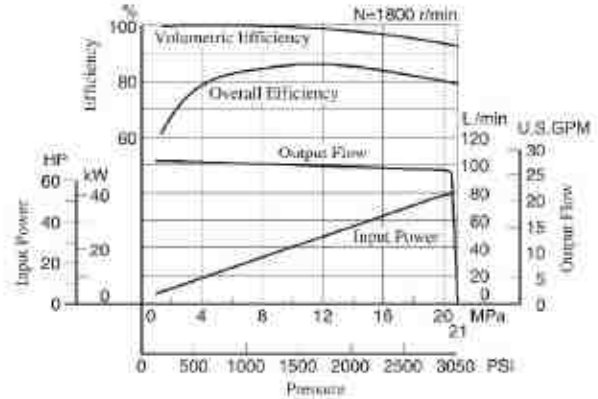
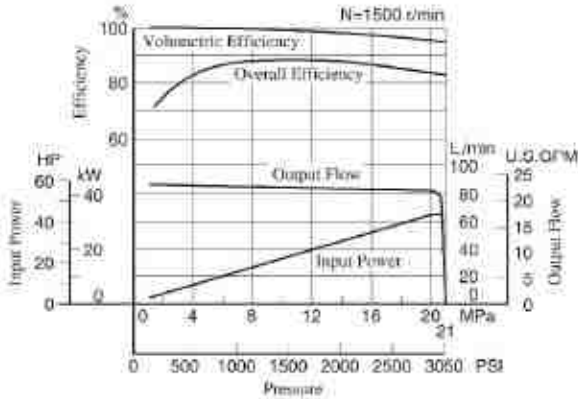

Input Power

Example: At a pressure of under 16 MPa (2320 PSI), a flow 70 L/min (18.5 U.S.GPM), and rotation 1500 r/min, the axial input becomes about 20.8 kW (27.9 HP) as shown the dotted line in the graph.

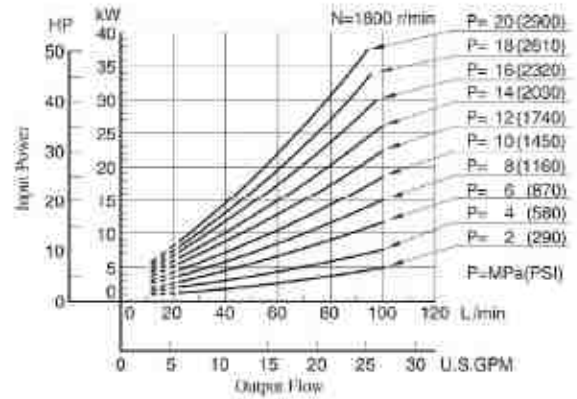
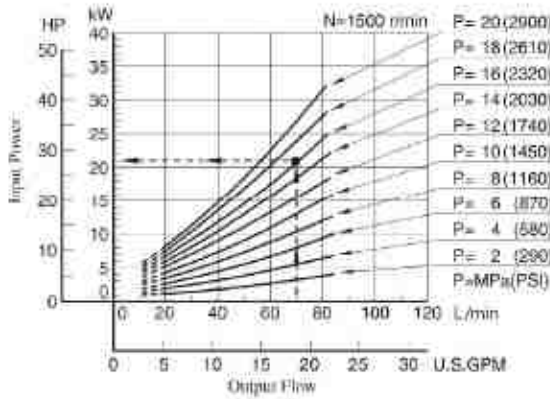

Full Cut-off Power

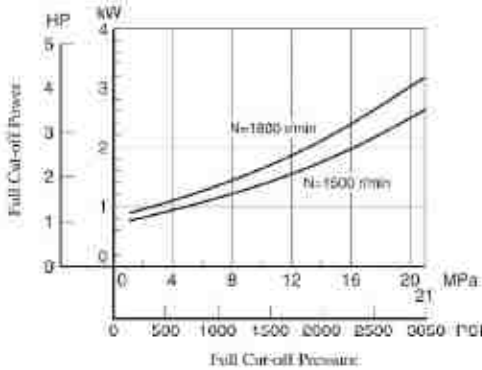

Drain

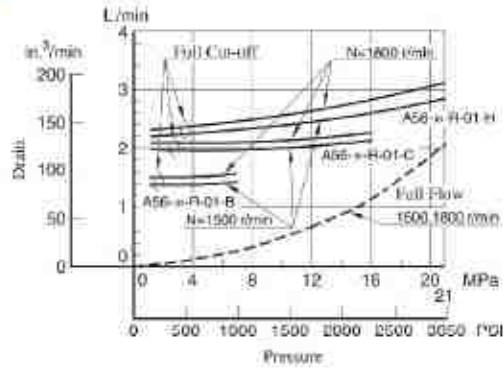

Noise Level [One metre (3.3 ft.) horizontally away from pump head cover]

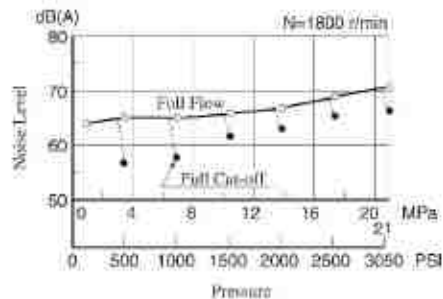
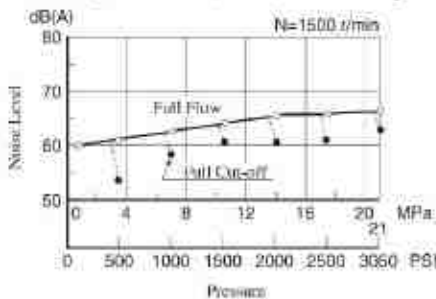



Typical Performance Characteristics of Type "A70" at Viscosity 32 mm²/s (150 SSU) [ISO VG32 Oils, 40°C (104°F)]

■ Performance Characteristics Curve

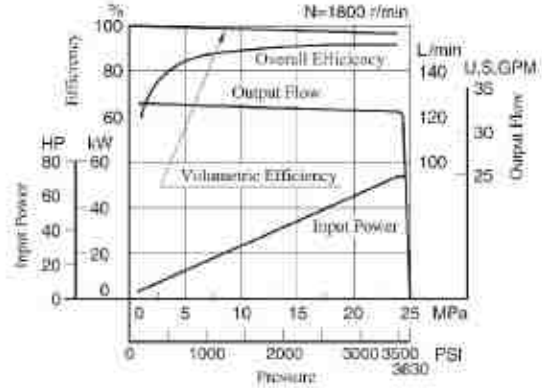
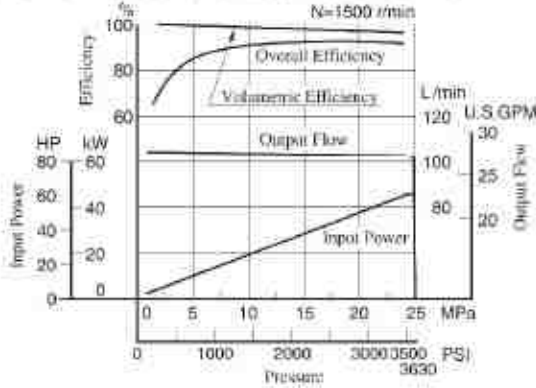

■ Input Power

Example: At a pressure of under 20 MPa (2900 PSI), a flow 70 L/min (18.5 U.S.GPM), and rotation 1500 r/min, the axial input becomes about 26 kW (35 HP) as shown the dotted line in the graph.

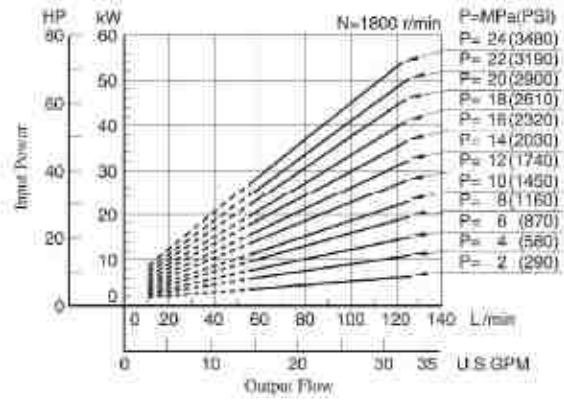
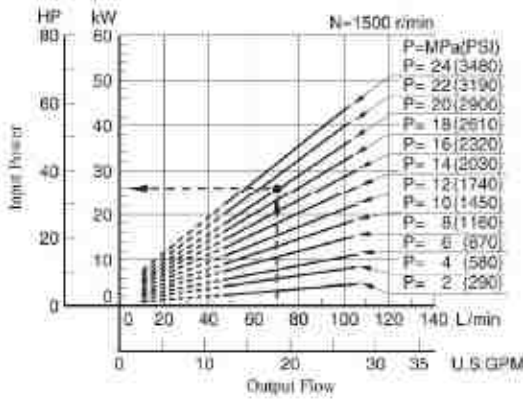

■ Full Cut-off Power

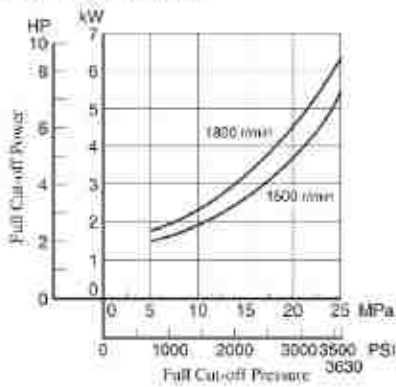

■ Drain

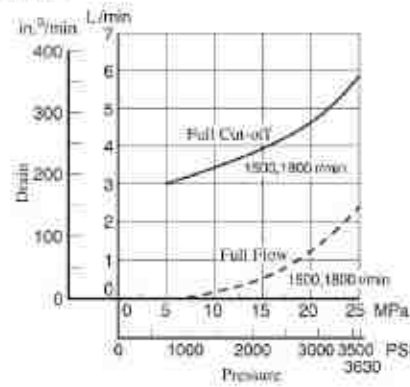

■ Noise Level [One metre (3.3 ft.) horizontally away from pump head cover]

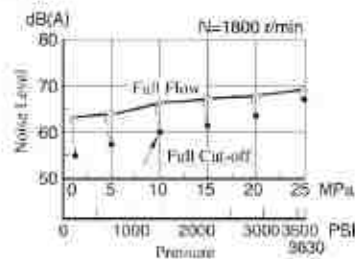
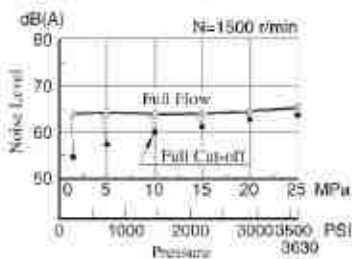

Typical Performance Characteristics of Type "A90" at Viscosity 32 mm²/s (150 SSU) [ISO VG32 Oils; 40°C (104°F)]

Performance Characteristics Curve

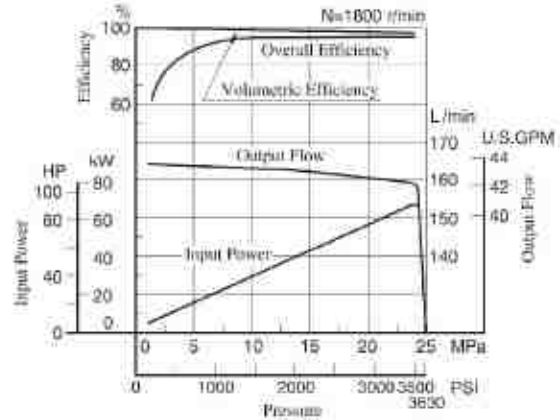
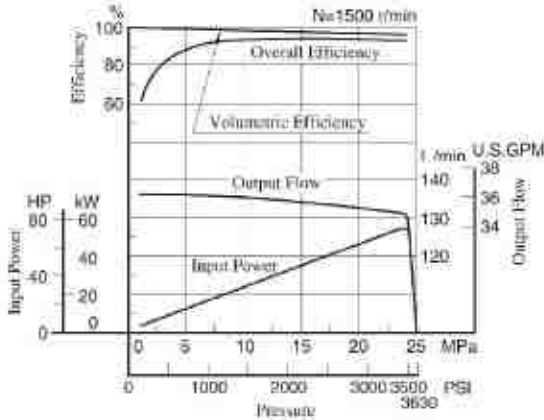

Input Power

Example: At a pressure of under 18 MPa (2610 PSI), a flow 110 L/min (29.1 U.S.GPM), and rotation 1500 r/min, the axial input becomes about 34 kW (46 HP) as shown the dotted line in the graph.

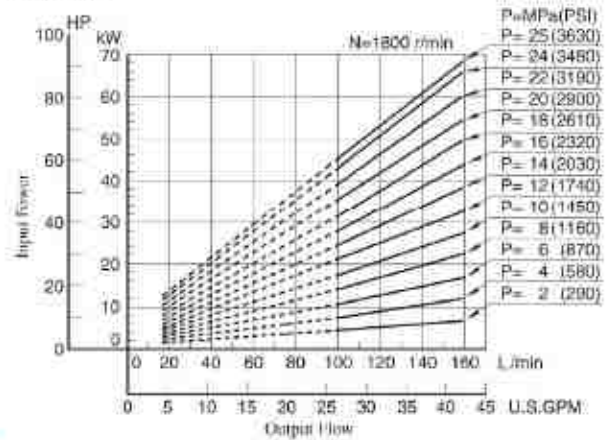
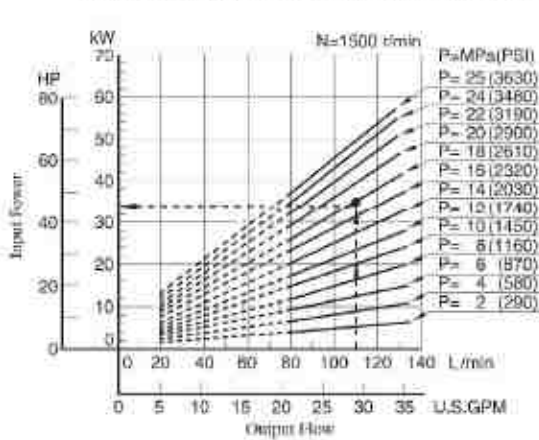

Full Cut-off Power

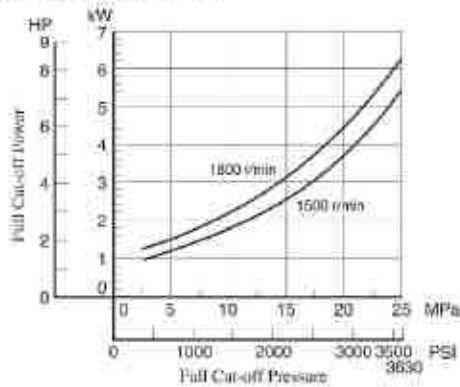

Drain

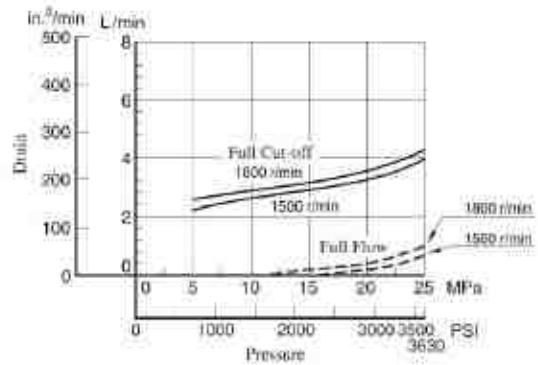

Noise Level (One metre (3.3 ft.) horizontally away from pump head cover)

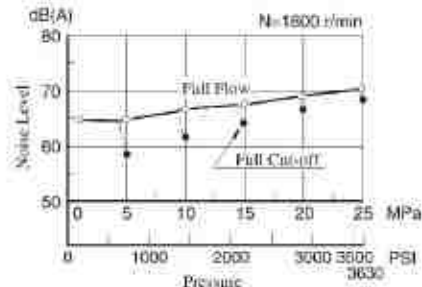
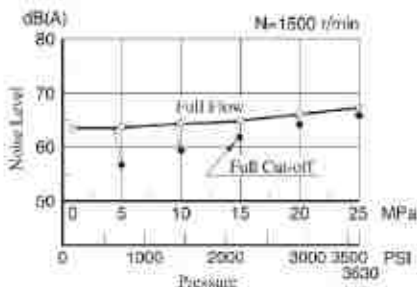



Typical Performance Characteristics of Type "A145" at Viscosity 32 mm²/s (150 SSU) [ISO VG32 Oils, 40°C (104°F)]

Performance Characteristics Curve

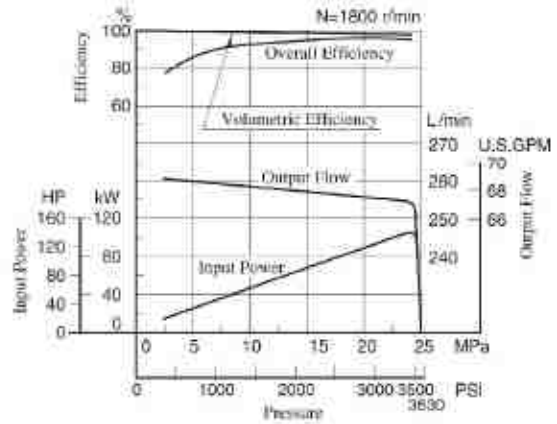
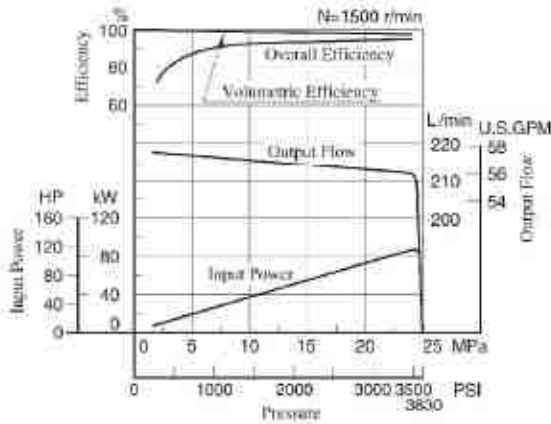

Input Power

Example: At a pressure of under 20 MPa (2900 PSI), a flow 180 L/min (47.6 U.S.GPM), and rotation 1500 r/min, the axial input becomes about 64 kW (86 HP) as shown the dotted line in the graph.

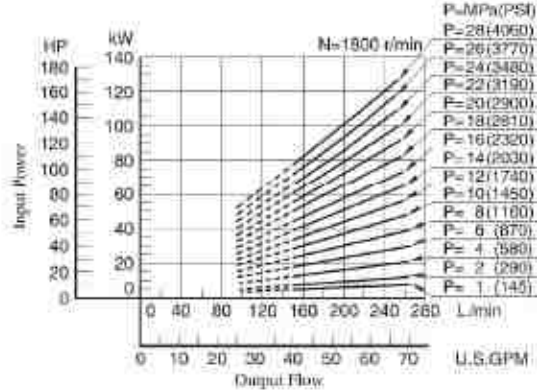
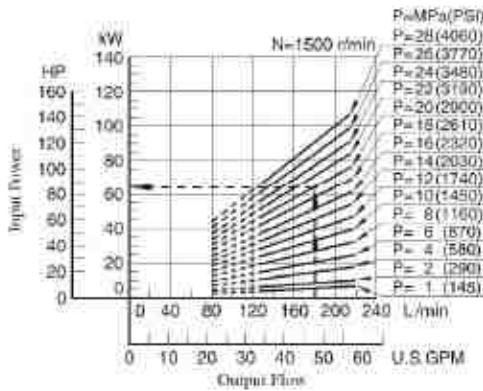

Full Cut-off Power

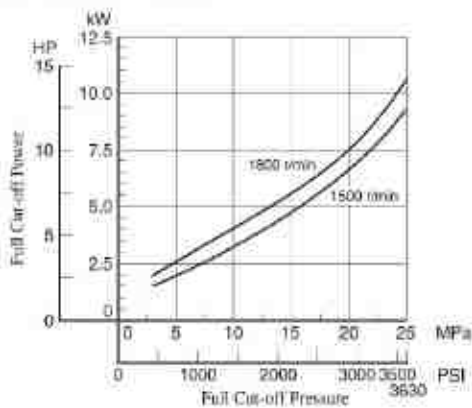

Drain

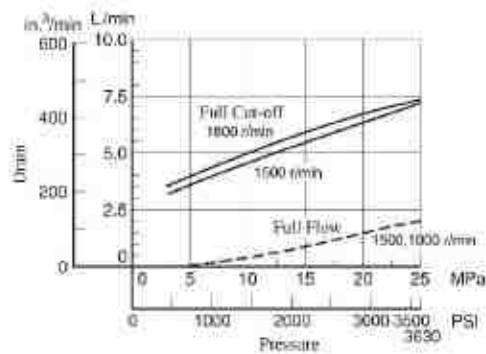

Noise Level [One metre (3.3 ft.) horizontally away from pump head cover]

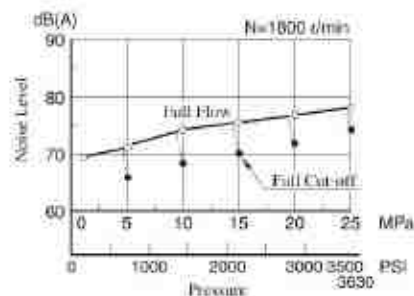
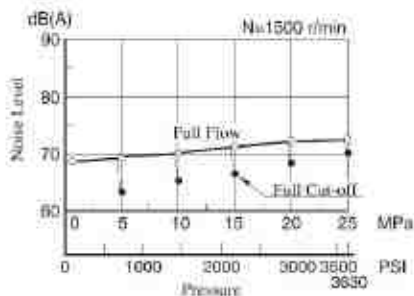

Flange Mtg.

DIMENSIONS IN MILLIMETRES (INCHES)

Pressure Adjustment Range "C" & "H"

- Japanese Standard "JIS": A10-FR01-C/H-12

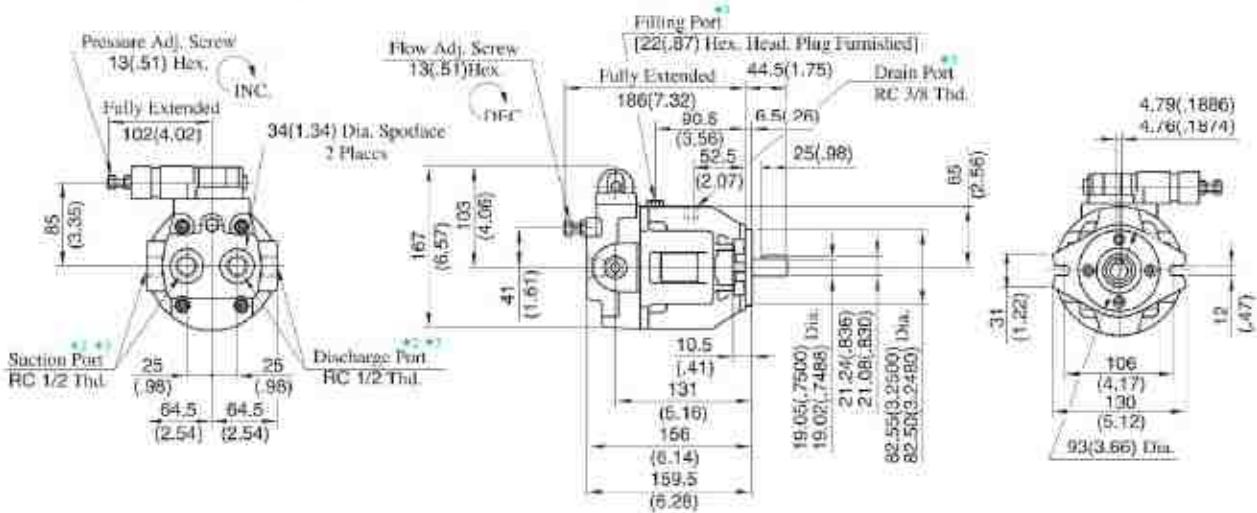

- European Design Standard: A10-FR01-C/H-1280
- N. American Design Standard: A10-FR01-C/H-12950

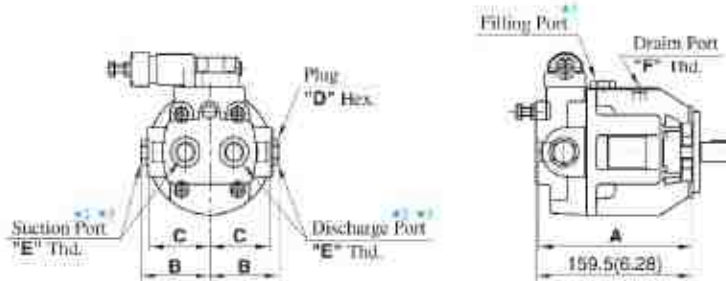

Model Numbers	Dimensions mm(Inches)				Thread Size	
	A	B	C	D	E	F
A10-FR01C/H-1280	159 (6.25)	72 (2.83)	64 (2.52)	27 (1.06)	1/2 BSP, F	3/8 BSP, F
A10-FR01C/H-12950	157 (6.18)	71 (2.80)	62 (2.44)	22 (.87)	SAE #8	SAE #6

• For other dimensions, refer to Japanese Standard "JIS".

Pressure Adjustment Range "B"

- Japanese Standard "JIS": A10-FR01-B-12

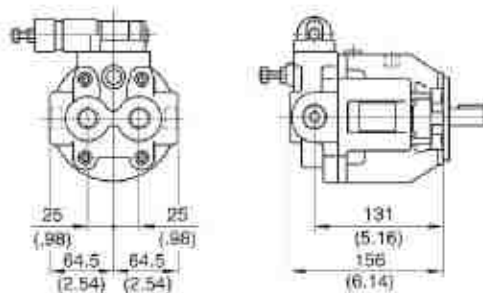

• For other dimensions, refer to above Pressure Adj. Range "C" & "H".

- ★ 1. Install the pump so that the "Filling Port" is at the top.
- ★ 2. Use either port of two suction and discharge ports at your option. Keep the remaining ports plugged.
- ★ 3. As the tightening torques of suction, discharge and drain port fittings, conform to the below.

Model Numbers	Tightening Torque Nm(IN. lbs.)	
	Suction Port & Discharge Port	Drain Port
A10-FR01B/C/H-12	65-75 (575-664)	40-50 (354-443)
A10-FR01C/H-1280	56-62 (496-549)	33-36 (292-319)
A10-FR01C/H-12950	47-51 (363-451)	40-50 (354-443)

Axial Port Type

Flange Mtg.: A16-F-R-01-#-K-32/3280/32950
 A22-F-R-01-#-K-32/3280/32950

Model Numbers	"C" Thd.	"D" Thd.
A16/A22-F-R-01-#-K-32	R: 3/8	M 10
A16/A22-F-R-01-#-K-3280	3/8 BSP.F	
A16/A22-F-R-01-#-K-3290	SAE #8	3/8-16 UNC

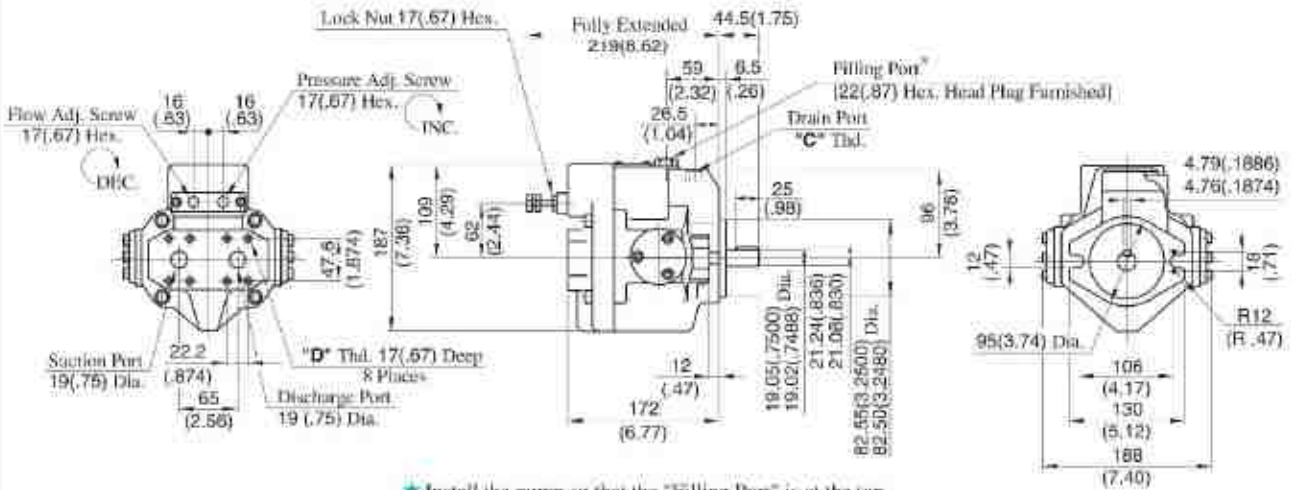

★ Install the pump so that the "Filling Port" is at the top.

Foot Mtg.: A16-L-R-01-#-K-32/3280/32950
 A22-L-R-01-#-K-32/3280/32950

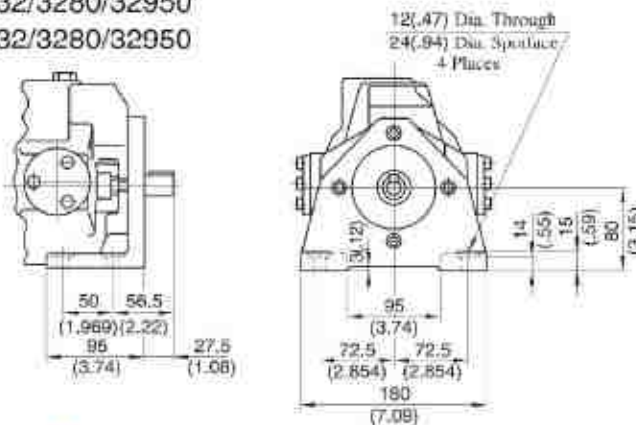

• For other dimensions, refer to "Flange Mtg."

Side Port Type

DIMENSIONS IN MILLIMETRES (INCHES)

Flange Mtg.: A16-F-R-01-#-S-K-32/3280/32950
 A22-F-R-01-#-S-K-32/3280/32950

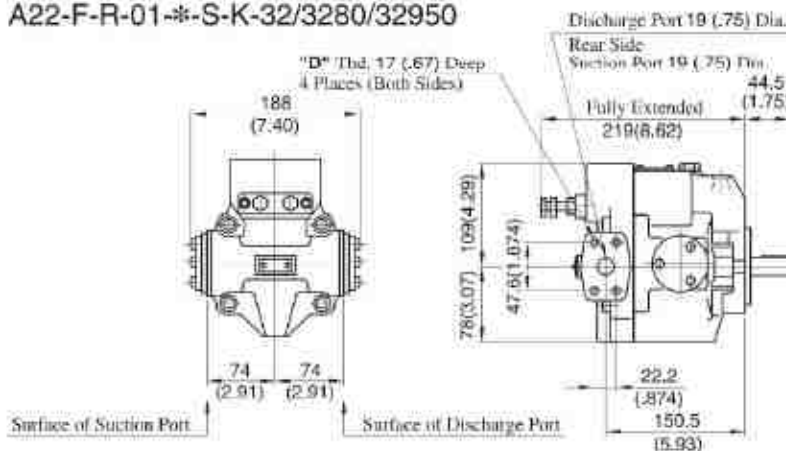

• For other dimensions, refer to "Axial Port Type".
 • Foot Mtg. Type: Mounting bracket is common to that of "Axial Port Type".

Axial Port Type

Flange Mtg.: A37-F-R-01-*****-K-32/3280/32950

Model Numbers	"C" Thd.	"D" Thd.	E mm (IN.)
A37-F-R-01- * -K-32	Rc 1/2	M 10	19 (.75)
A37-F-R-01- * -K-3280	1/2 BSP.F		
A37-F-R-01- * -K-32950	SAE #10	7/16-14 UNC	20 (.79)

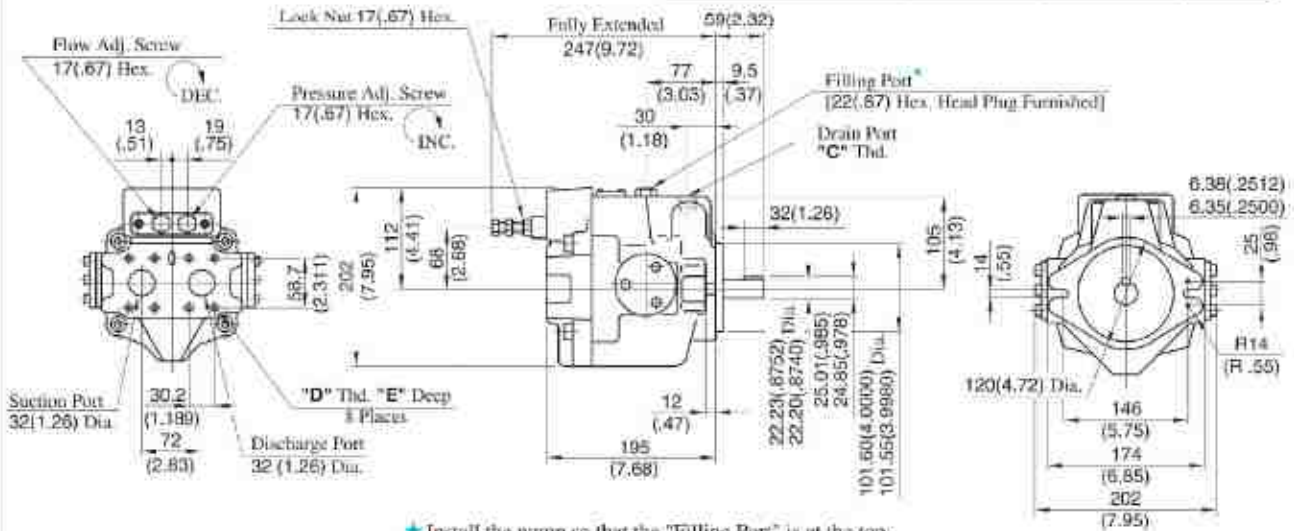

Foot Mtg.: A37-L-R-01-*****-K-32/3280/32950

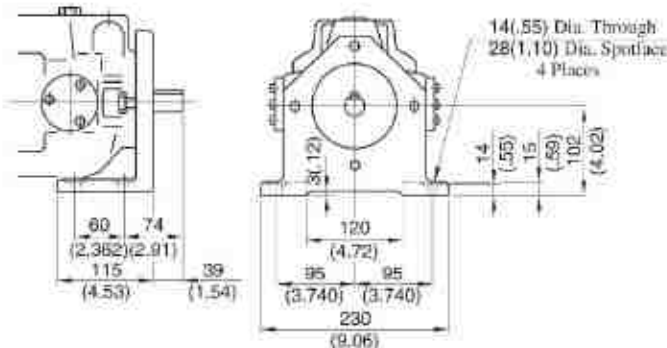

Side Port Type

DIMENSIONS IN MILLIMETRES (INCHES)

Flange Mtg.: A37-F-R-01-*****-S-K-32/3280/32950

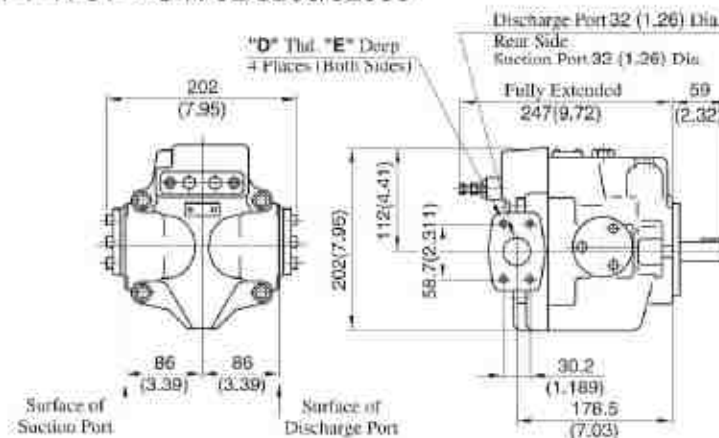

Axial Port Type

Flange Mtg.: A56-F-R-01-#-K-32/3280/32950

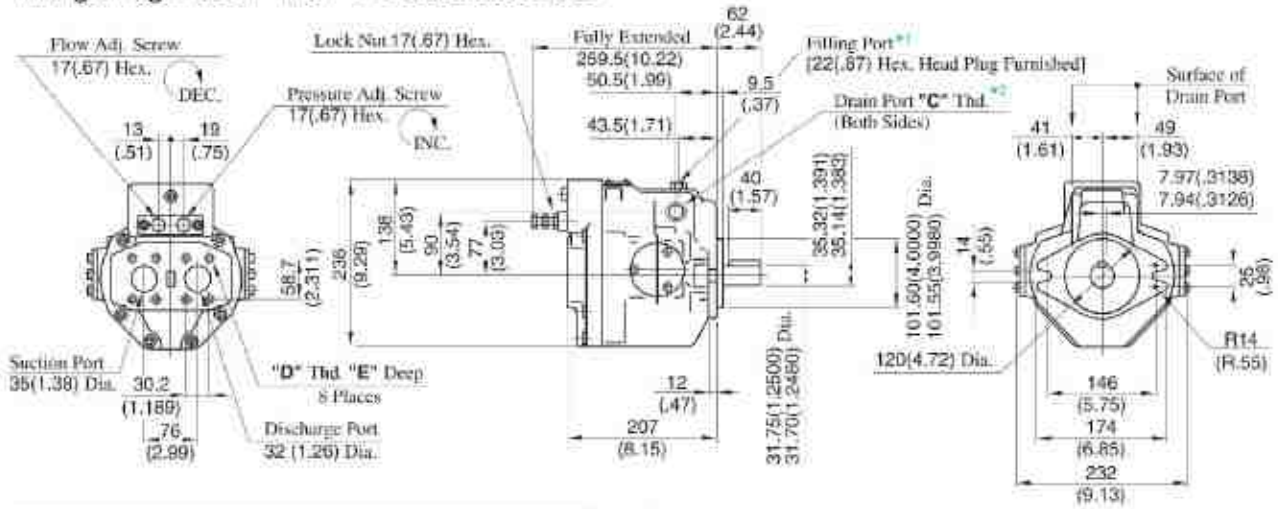

Model Numbers	"C" Thd.	"D" Thd.	E mm (IN.)
A56-F-R-01-#-K-32	Rc 3/4	M 10	19 (.75)
A56-F-R-01-#-K-3280	3/4 BSP.F	M 10	19 (.75)
A56-F-R-01-#-K-32950	SAE #12	7/16-14 UNC	20 (.79)

- *1 Install the pump so that the "Filling Port" is at the top.
- *2 Use either port of the two drain ports at your option. Keep the remaining port plugged.

Foot Mtg.: A56-L-R-01-#-K-32/3280/32950

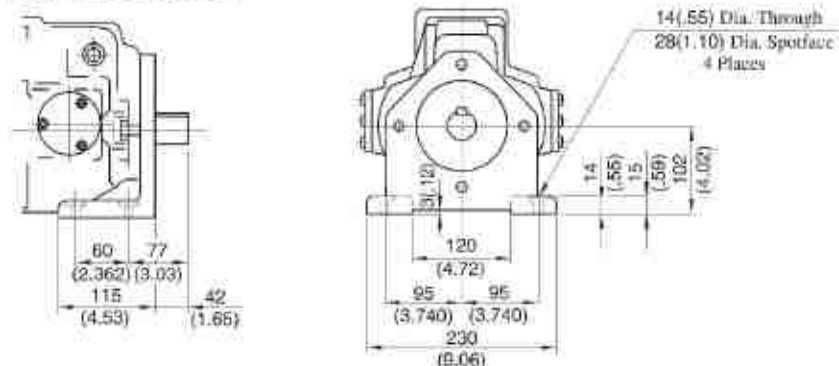

* For other dimensions, refer to "Flange Mtg.".

Side Port Type

DIMENSIONS IN MILLIMETRES (INCHES)

Flange Mtg.: A56-F-R-01-#-S-K-32/3280/32950

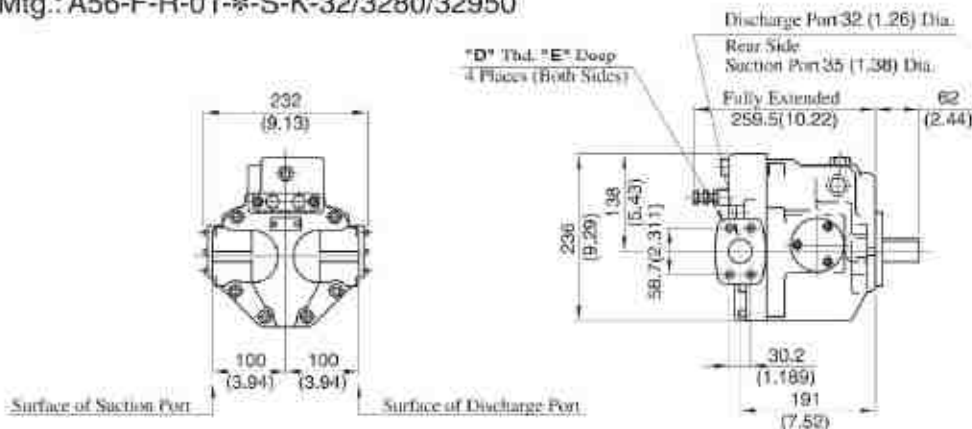

- * For other dimensions, refer to "Axial Port Type".
- * Foot Mtg. Type: Mounting bracket is common to that of "Axial Port Type".

Flange Mtg.: A70-FR01*S-60/6080/60950

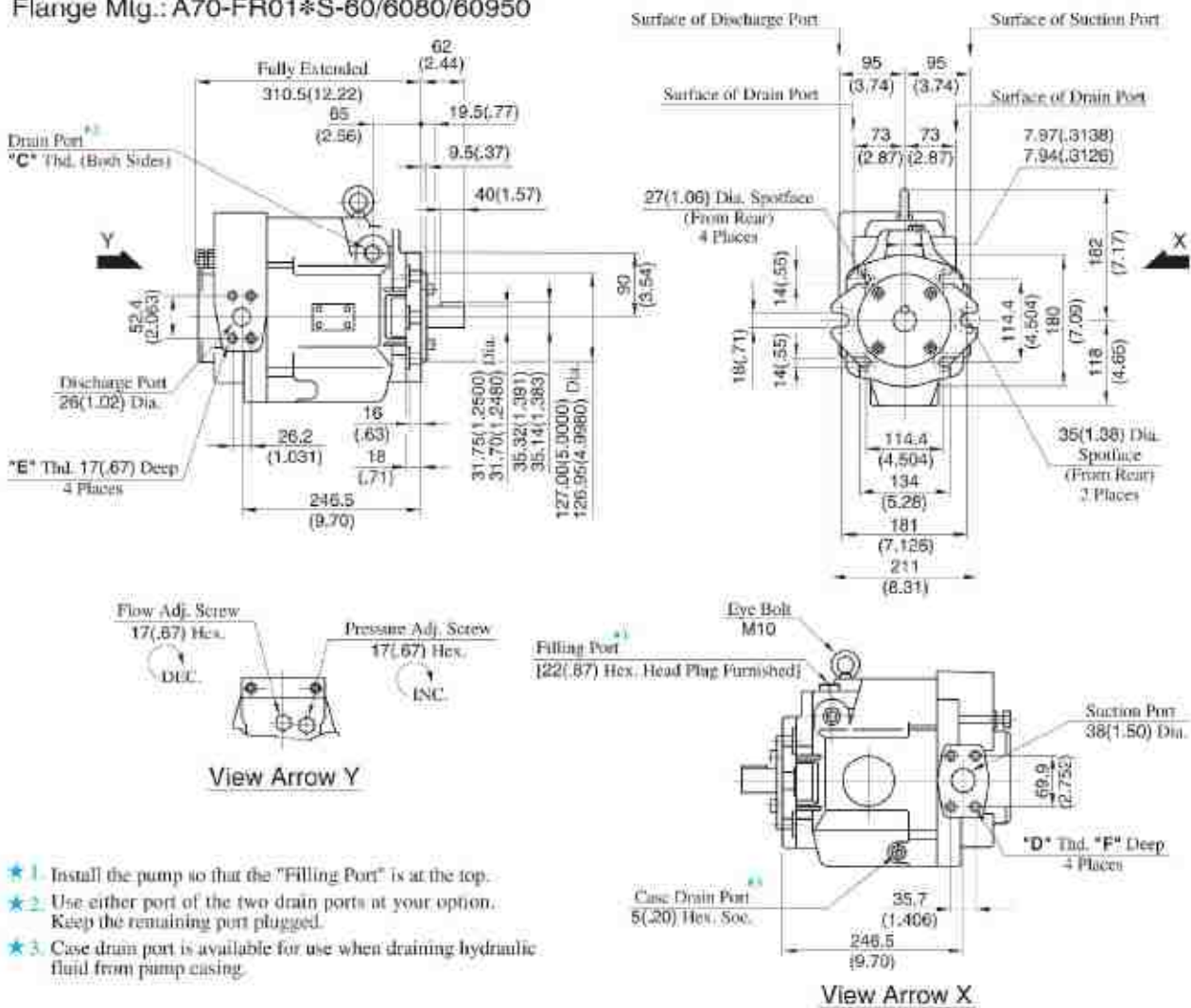

- ★ 1. Install the pump so that the "Filling Port" is at the top.
- ★ 2. Use either port of the two drain ports at your option. Keep the remaining port plugged.
- ★ 3. Case drain port is available for use when draining hydraulic fluid from pump casing.

DIMENSIONS IN MILLIMETRES (INCHES)

Foot Mtg.: A70-LR01*S-60/6080/60950

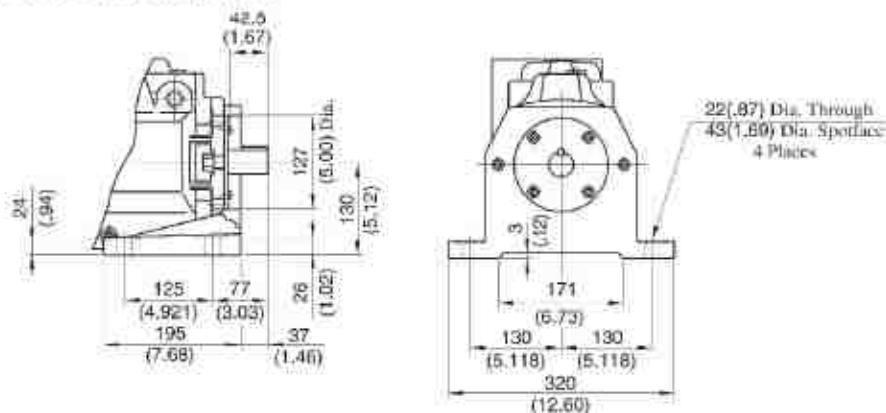

• For other dimensions, refer to "Flange Mtg."

Flange Mtg.: A90-FR01*S-60/6080/60950

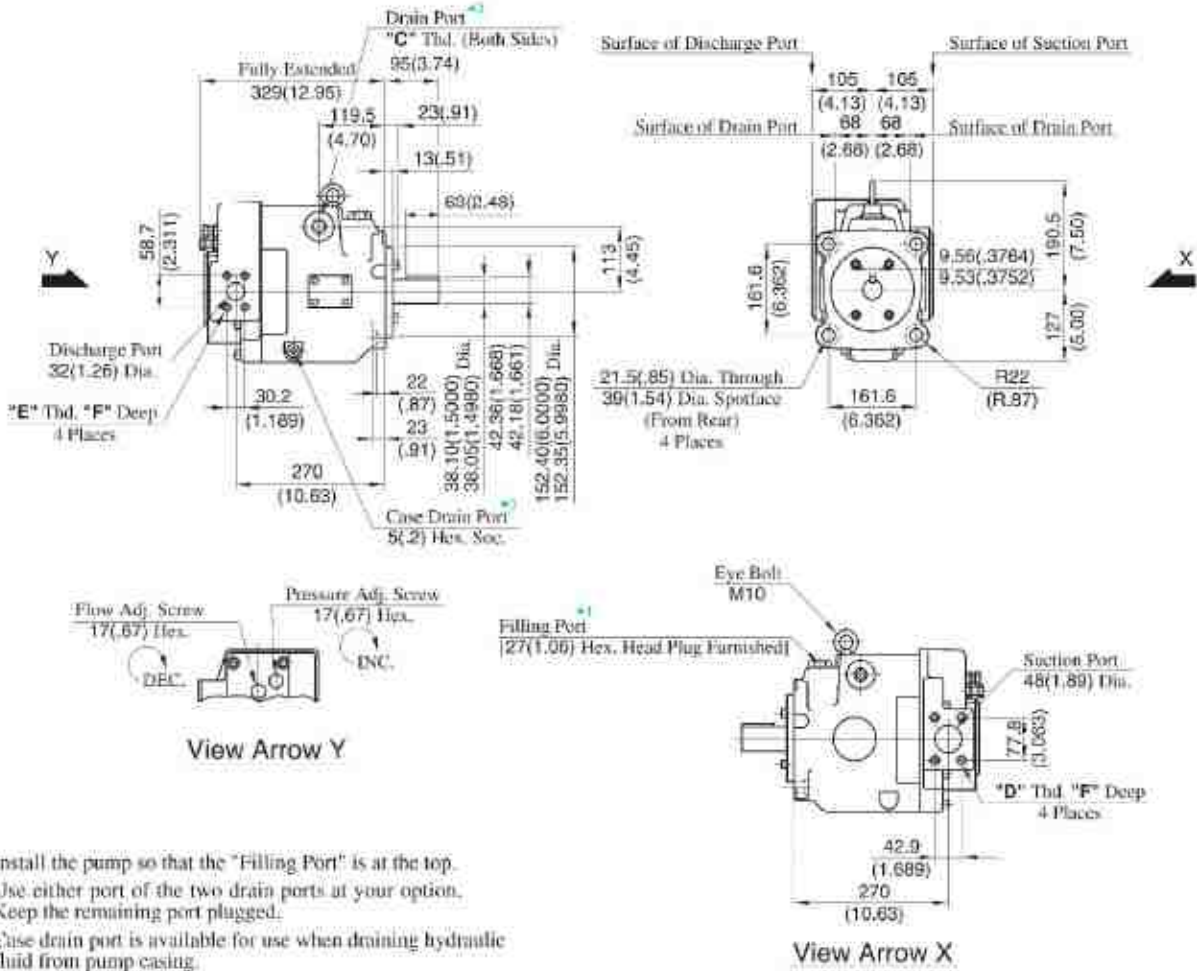

Model Numbers	"C" Thd.	"D" Thd.	"E" Thd.	F mm (IN.)
A90-FR01*S-60	Rc 3/4	M 12	M 10	19 (.75)
A90-FR01*S-6080	3/4 BSP.F			
A90-FR01*S-60950	SAE #12	1/2-13 UNC	7/16-14 UNC	21 (.83)

DIMENSIONS IN MILLIMETRES (INCHES)

Foot Mtg.: A90-LR01*S-60/6080/60950

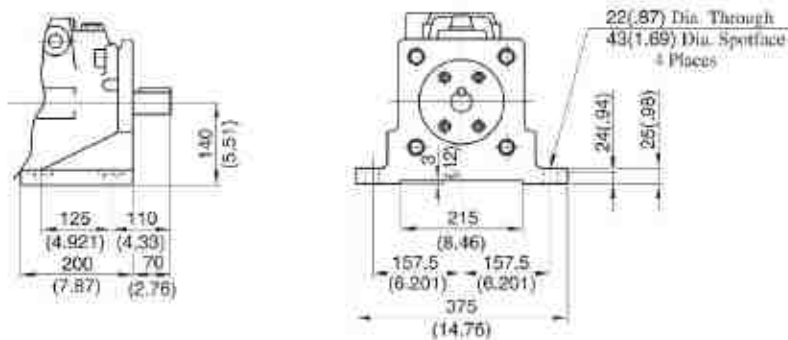

• For other dimensions, refer to "Flange Mtg."

Flange Mtg.: A145-FR01*S-60/6080/60950

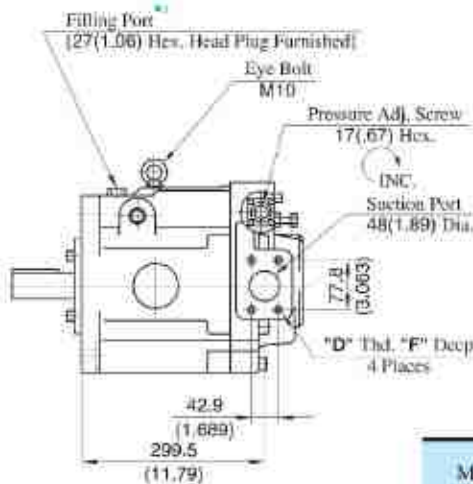
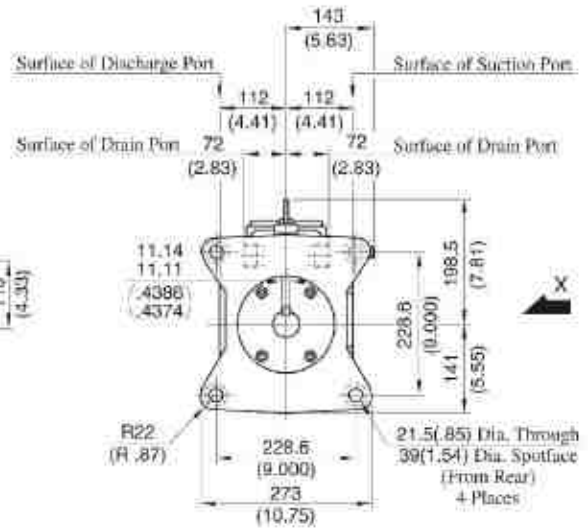
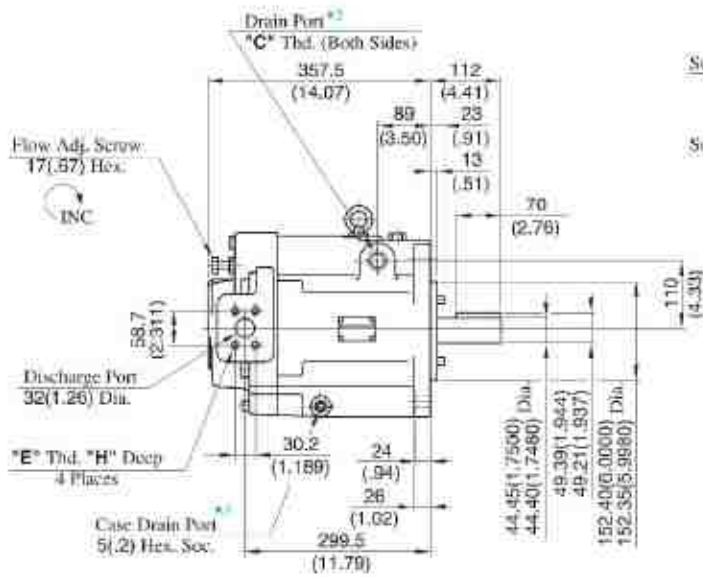

View Arrow X

- ★ 1. Install the pump so that the "Filling Port" is at the top.
- ★ 2. Use either port of the two drain ports at your option. Keep the remaining port plugged.
- ★ 3. Case drain port is available for use when draining hydraulic fluid from pump casing.

Model Numbers	"C" Thd.	"D" Thd.	"E" Thd.	Dimensions mm (IN.)	
				F	H
A145-FR01*S-60	Rc 3/4	M 12	M 10	19 (.75)	19 (.75)
A145-FR01*S-6080	3/4 BSP.F	M 12	M 10	19 (.75)	19 (.75)
A145-FR01*S-60950	SAE #12	1/2-13 UNC	7/16-14 UNC	21 (.83)	20 (.79)

DIMENSIONS IN MILLIMETRES (INCHES)

Foot Mtg.: A145-LR01*S-60/6080/60950

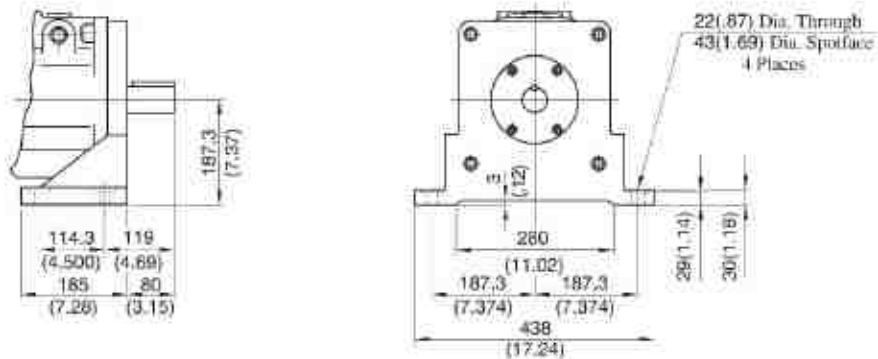

• For other dimensions, refer to "Flange Mtg."

■ Spare Parts List

A10-FR01-B-12
 A10-FR01C/H-12/1280/12950

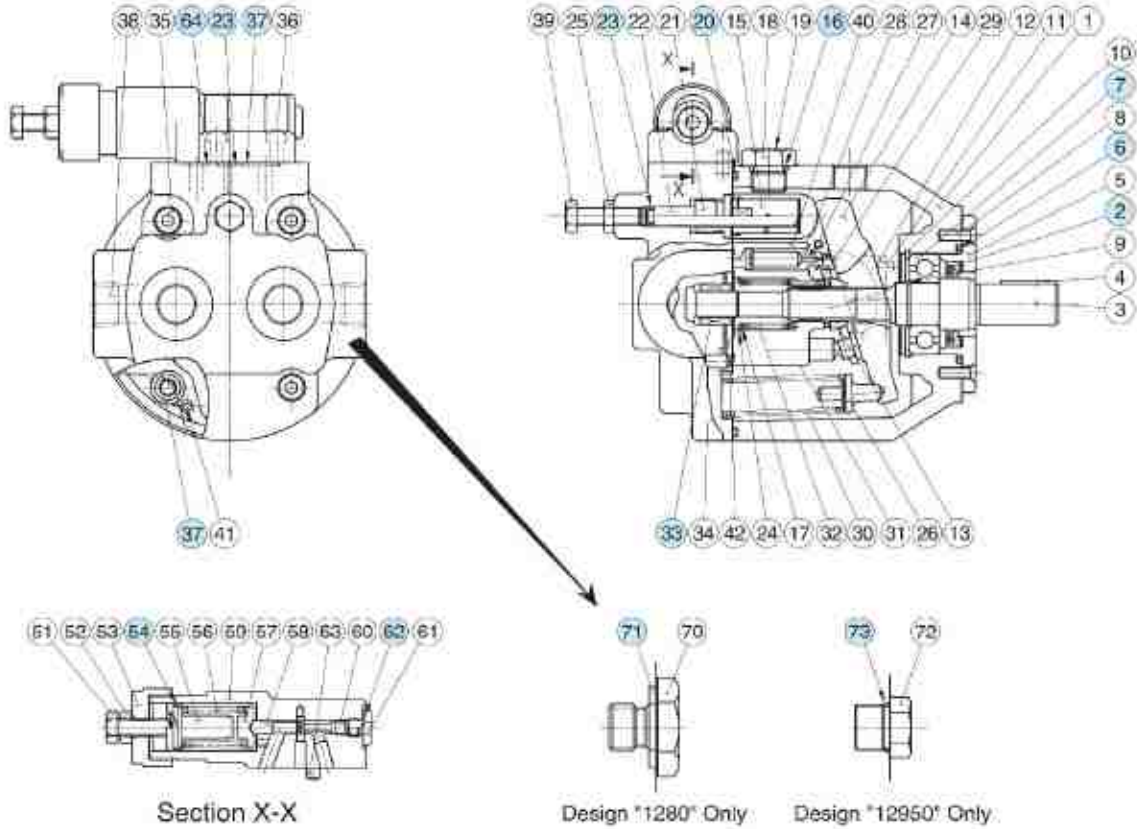

● List of Seals & Bearings

Item	Name of Parts	Part Numbers	Qty.		Remarks
			Pres. Adj. Range		
			B	C & H	
2*	Oil Seal	TCN24408Y	1	1	
6*	O-Ring	SO-NA-G50	1	1	
7	Bearing	6204	1	1	
16*	O-Ring	SO-NB-P14	1	1	
20*	O-Ring	SO-NB-G120	1	1	
23*	O-Ring	SO-NB-P6	2	2	
33	Bearing	HMK1215	1	1	
37*	O-Ring	SO-NB-P12	6	5	
54*	O-Ring	SO-NA-A018	1	1	
62*	O-Ring	SO-NB-P10	1	1	
64*	O-Ring	SO-NB-P9	—	1	
71	Bonded Seal	KP-C-04	—	2	Only for "1280" Design, Not included in Seal Kit
73	O-Ring	AS568-908 (NBR, Hs90)	—	2	Only for "12950" Design, Not included in Seal Kit

★ When ordering seals, please specify the seal kit number from the table below.

● List of Seal Kits

Pump Model Numbers	Seal Kit Numbers
A10-FR01B-12	KS-A10-01B-12
A10-FR01C-12/1280/12950	KS-A10-01H-12
A10-FR01H-12/1280/12950	

Spare Parts List

A16/A22/A37/A56- ϕ -R-01- ϕ - ϕ -K-32/3280/32950

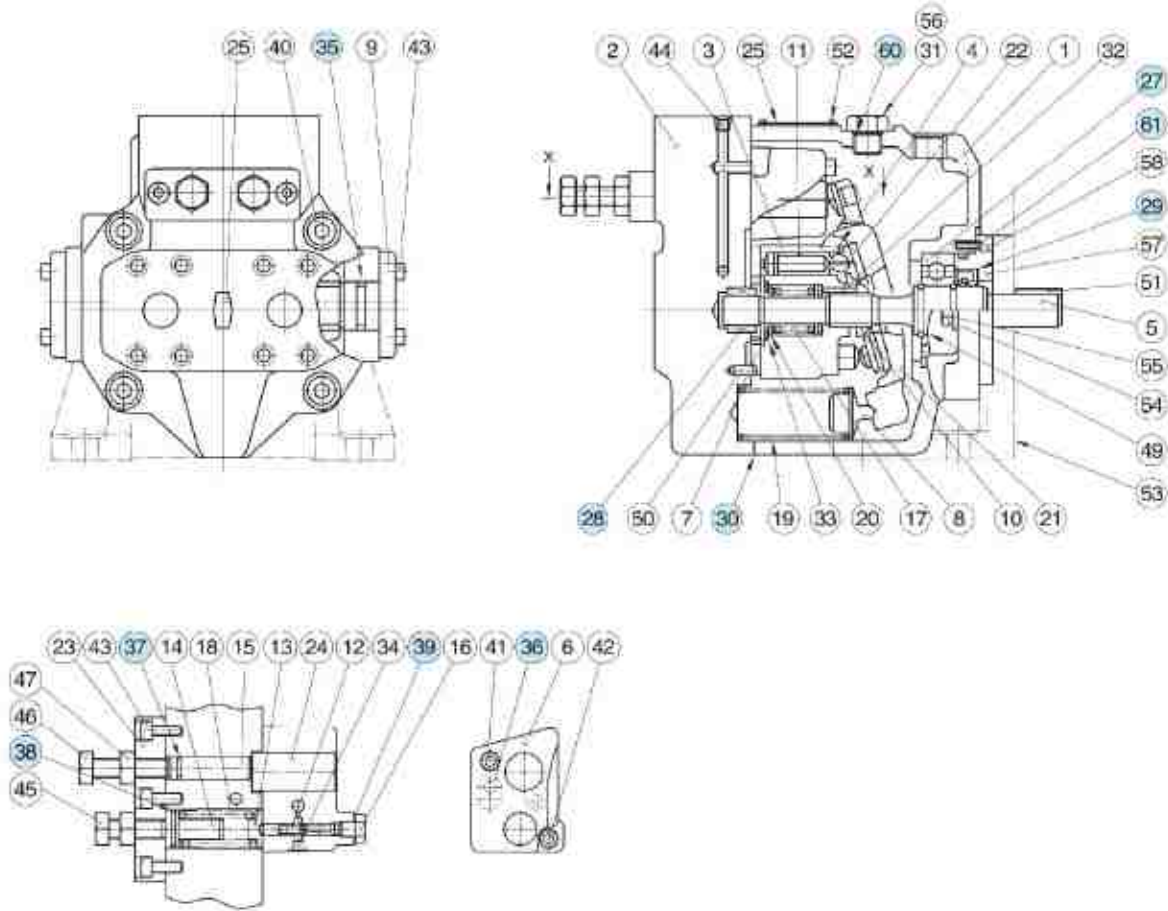

Section X-X

List of Seals and Bearings

Item	Name of Parts	Part Numbers				Qty.
		A16- ϕ -R-01	A22- ϕ -R-01	A37- ϕ -R-01	A56- ϕ -R-01	
27	Bearing	6305		6307	NUP 207E	1
28	Bearing	HMK 1715	Z30-1303-PK410300-8	HMK 2025V2	HMK 2530V2	1
29*	Oil Seal	TCN 254511		TCN 355511	TCN 355511	1
30*	Gasket	1303-PK211969-1		1316-PK211970-9	1307-PK211971-7	1
35*	O-Ring	SO-NA-G25		SO-NA-G30	SO-NA-P36	2
36*	O-Ring	SO-NB-P12		SO-NB-P10A		1
37*	O-Ring	SO-NB-P9				1
38*	O-Ring	SO-NA-A017				1
39*	Seal Washer	W8				1
60*	O-Ring	SO-NB-P14				1
61*	O-Ring	SO-NA-G55		SO-NA-G75		1

*When ordering seals, please specify the seal kit number from the table below.

List of Seal Kits

Pump Model Numbers	Seal Kit Numbers
A16- ϕ -R-01- ϕ -K- ϕ -32 ϕ	KS-A16-01-32
A22- ϕ -R-01- ϕ -K- ϕ -32 ϕ	
A37- ϕ -R-01- ϕ -K- ϕ -32 ϕ	KS-A37-01-32
A56- ϕ -R-01- ϕ -K- ϕ -32 ϕ	KS-A56-01-32

■ Spare Parts List

A70/A90-#R01#S-60/6080/60950

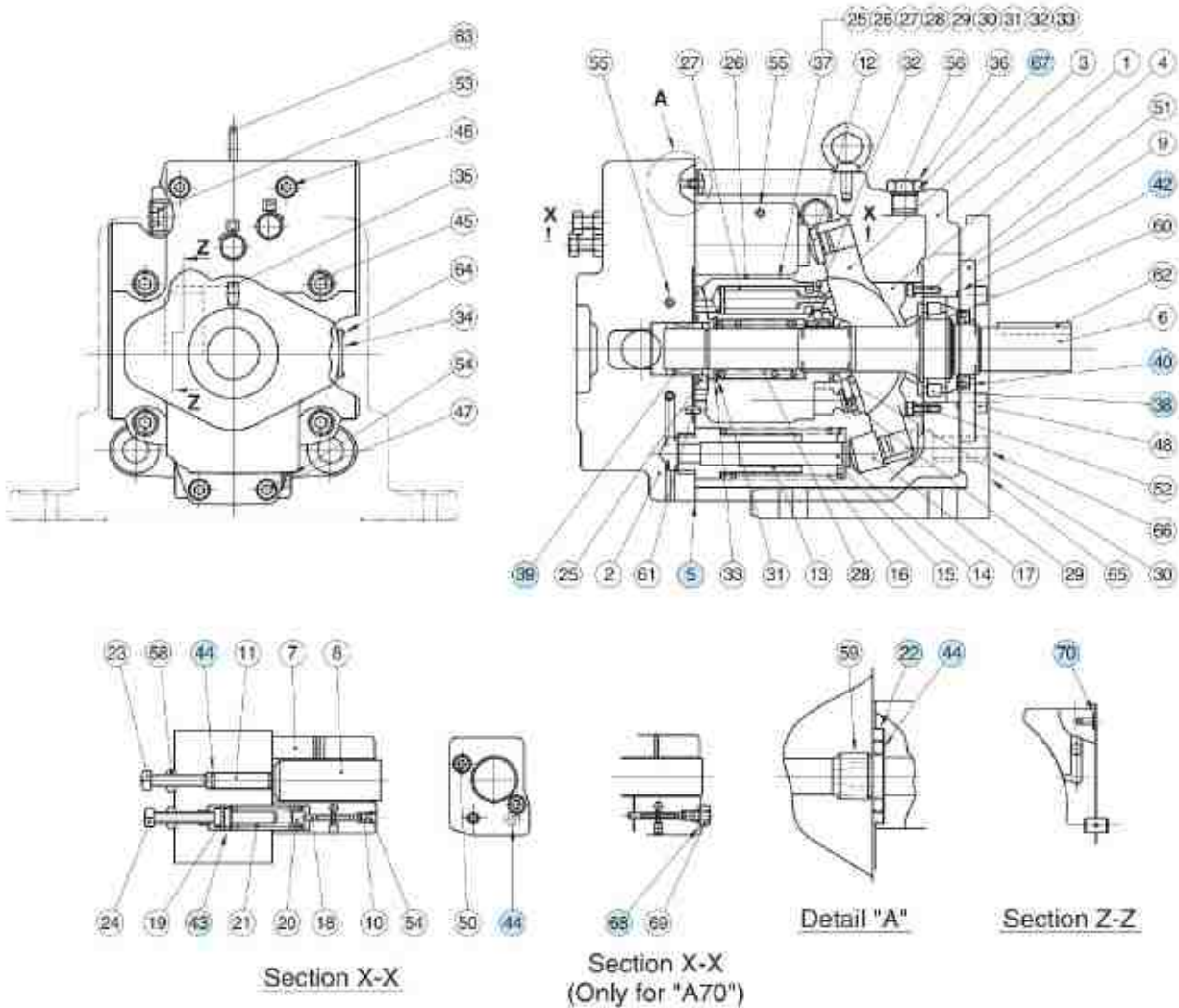

● List of Seals and Bearings

Item	Name of Parts	Part Numbers		Qty.
		A70-#R01#S	A90-#R01#S	
5*	Gasket	1314E-PK211972-5	1310E-PK211973-3	1
22	Back Up Ring	1310E-PK412440-0	1310E-PK412440-0	1
38	Bearing	NUP 208EX50	NUP 210E	1
39	Needle Bearing	HMK 3030V2	HMK 3530BV2	1
40*	Oil Seal	TCN 355511	TCN 456812	1
42*	O-Ring	SO-FA-G85	SO-FA-G95	1
43*	O-Ring	SO-NA-P18	SO-NA-P18	1
44*	O-Ring	SO-NB-P9	SO-NB-P9	3
67*	O-Ring	SO-NB-P14	SO-NB-P18	1
68*	Seal Washer	W10	—	1
70*	O-Ring	SO-NB-P15	SO-NB-P5	1

● List of Seal Kits

Pump Model Numbers	Seal Kit Numbers
A70-#R01#S-60#	KS-A70-01-60
A90-#R01#S-60#	KS-A90-01-60

* When ordering the seals, please specify the seal kit number from the table left.

Spare Parts List

A145-*R01*S-60/6080/60950

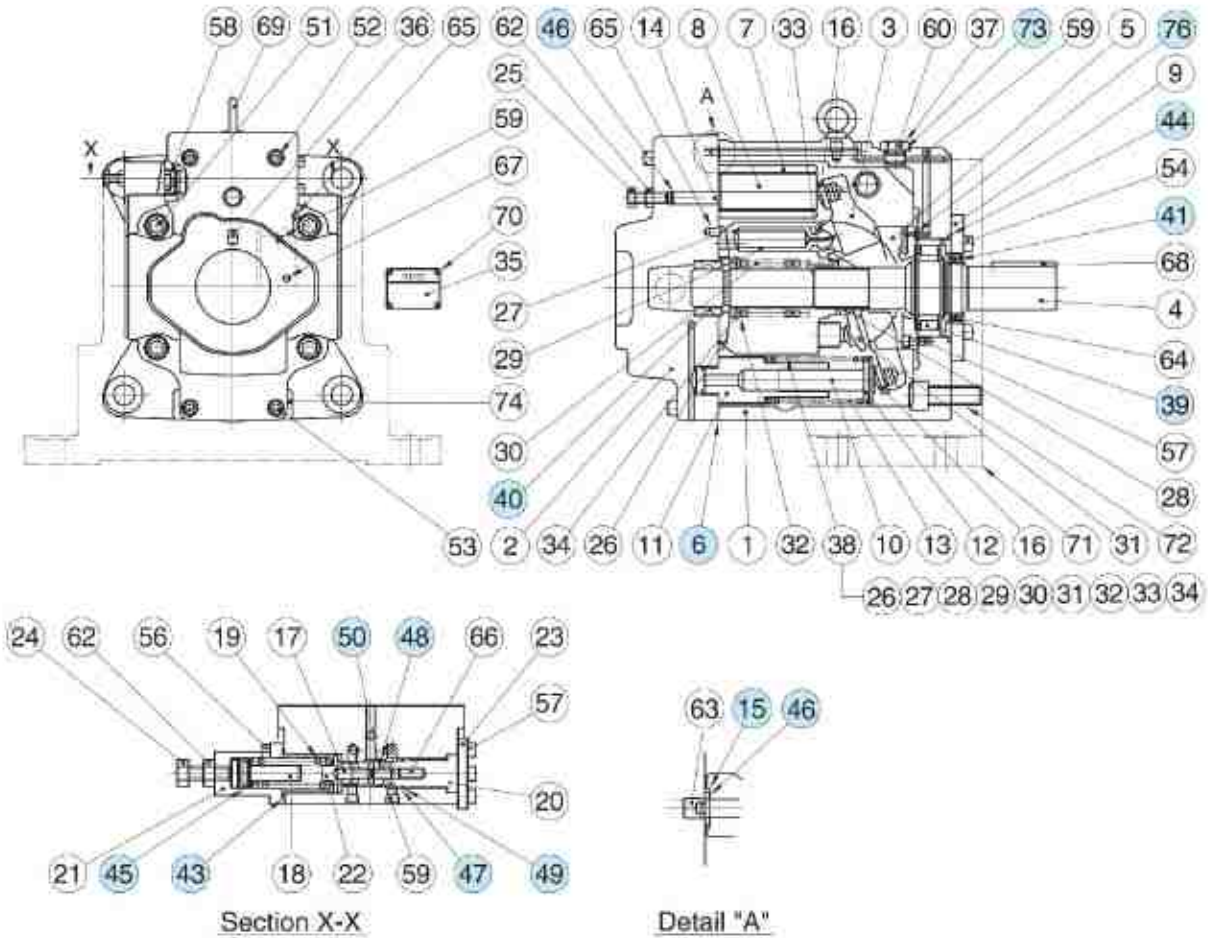

● List of Seals and Bearings

Item	Name of Parts	Part Numbers	Qty.
6*	Gasket	1312-PK211974-1	1
15	Back Up Ring	1310E-PK412440-0	1
39	Bearing	NUP 2211ET2	1
40	Needle Bearing	8Q-NK38×55×30	1
41*	Oil Seal	TCN 507212	1
43*	O-Ring	S-31.5 (NBR, H570)	1
44*	O-Ring	SO-FA-G105	1
45*	O-Ring	SO-NA-P18	1
46*	O-Ring	SO-NB-P9	2
47*	O-Ring	SO-NA-A017	1
48*	O-Ring	SO-NA-A016	1
49	Back Up Ring	For SO-NB-A017	1
50	Back Up Ring	For SO-NB-A016	1
73*	O-Ring	SO-NB-P18	1
76*	O-Ring	SO-NB-P5	1

* When ordering seals, please specify the kit number "KS-A145-01-60".



"A" Series Variable Displacement Piston Pumps – Single Pump, Solenoid Two Pressure Control Type

Graphic Symbol

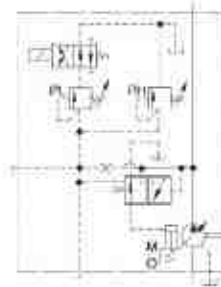

Performance Characteristics

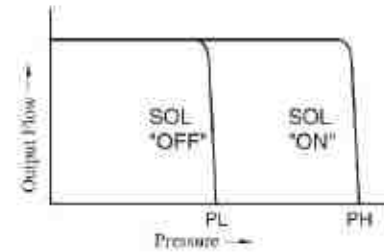

Specifications

Model Numbers	Geometric Displacement cm ³ /rev (cu. in./rev)	Minimum Adj. Flow cm ³ /rev (cu. in./rev)	Operating Pressure MPa (PSI)		Minimum Adj. Pres. MPa (PSI)	Shaft Speed Range r/min		Approx. Mass kg (lbs.)	
			Rated ^{★1}	Intermittent ^{★2}		Max.	Min.	Flange Mtg.	Foot Mtg.
A16-∗-R-02-∗-K∗-32∗	15.8 (.964)	4 (.244)	16 (2320)	21 (3050)	1.2 (170)	1800	600	24.5 (54.0)	26.7 (58.9)
A22-∗-R-02-∗-K∗-32∗	22.2 (1.355)	6 (.366)	16 (2320)	16 (2320)	1.2 (170)	1800	600	24.5 (54.0)	26.7 (58.9)
A37-∗-R-02-∗-K∗-32∗	36.9 (2.25)	10 (.61)	16 (2320)	21 (3050)	1.2 (170)	1800	600	36 (79.4)	40.3 (88.9)
A56-∗-R-02-∗-K∗-32∗	56.2 (3.43)	12 (.73)	16 (2320)	21 (3050)	1.2 (170)	1800	600	43 (94.8)	47.3 (104)
A70-∗R02S∗-60∗	70.0 (4.27)	30 (1.83)	25 (3630)	25 (3630)	2 (290)	1800	600	63.5 (140)	75.5 (166)
A90-∗R02S∗-60∗	91.0 (5.55)	56 (3.42)	25 (3630)	25 (3630)	2 (290)	1800	600	80.5 (178)	101 (223)
A145-∗R02S∗-60∗	145 (8.85)	83 (5.06)	25 (3630)	25 (3630)	2 (290)	1800	600	97.5 (215)	122.5 (270)

★1. Whenever setting pressure, make sure the full cut-off pressure never exceeds the maximum intermittent pressure. ★2. When operating the pump exceeding the rated pressure, operating conditions are restricted. Refer to page 33 for the details.

Solenoid Ratings

Solenoid operated directional valves used on these pumps are YUKEN DSG-01 series (standard type). For detail specifications of solenoid operated directional valves, refer to page 345.

■ Model Number Designation

A16	-F	-R	-02	-S	-K	-A100	-32	*
Series Number	Mounting	Direction of Rotation	Control Type	Port Position	Shaft Extension	Coil Type of Solenoid Valve	Design Number	Design Std.
A16 (15.8 cm ³ /rev)	F: Flange Mtg. L: Foot Mtg.	(Viewed from Shaft End) R: Clockwise* (Normal)	02: Solenoid Two Pressure Control Type	None: Axial Port S: Side Port	K: Keyed Shaft	AC A100, A120 A200, A240 DC D12, D24 D48 R(AC→DC Rectified) R100, R200	32	Refer to*2
A22 (22.2 cm ³ /rev)							32	
A37 (36.9 cm ³ /rev)							32	
A56 (56.2 cm ³ /rev)							32	

A70	-F	R	02	S	A100	-60	*
Series Number	Mounting	Direction of Rotation	Control Type	Port Position	Coil Type of Solenoid Valve	Design Number	Design Std.
A70 (70.0 cm ³ /rev)	F: Flange Mtg. L: Foot Mtg.	(Viewed from Shaft End) R: Clockwise* (Normal)	02: Solenoid Two Pressure Control Type	S: Side Port	AC A100, A120 A200, A240 DC D12, D24 D48 R(AC→DC Rectified) R100, R200	60	Refer to*2
A90 (91.0 cm ³ /rev)						60	
A145 (145 cm ³ /rev)						60	

*1 Available to supply pump with anti-clockwise rotation. Consult Yuken for details.

*2 Design Standards: None Japanese Standard "JIS"
 80 European Design Standard
 950 N. American Design Standard

■ Performance Characteristics

For performance characteristics, refer to models of pressure compensator type on page 37 to 43.

■ Pipe Flange Kits

For pipe flange, refer to form of pressure compensator type on page 34.

Axial Port Type

Flange Mtg.: A16-F-R-02-K*-32/32950
 A22-F-R-02-K*-32/32950

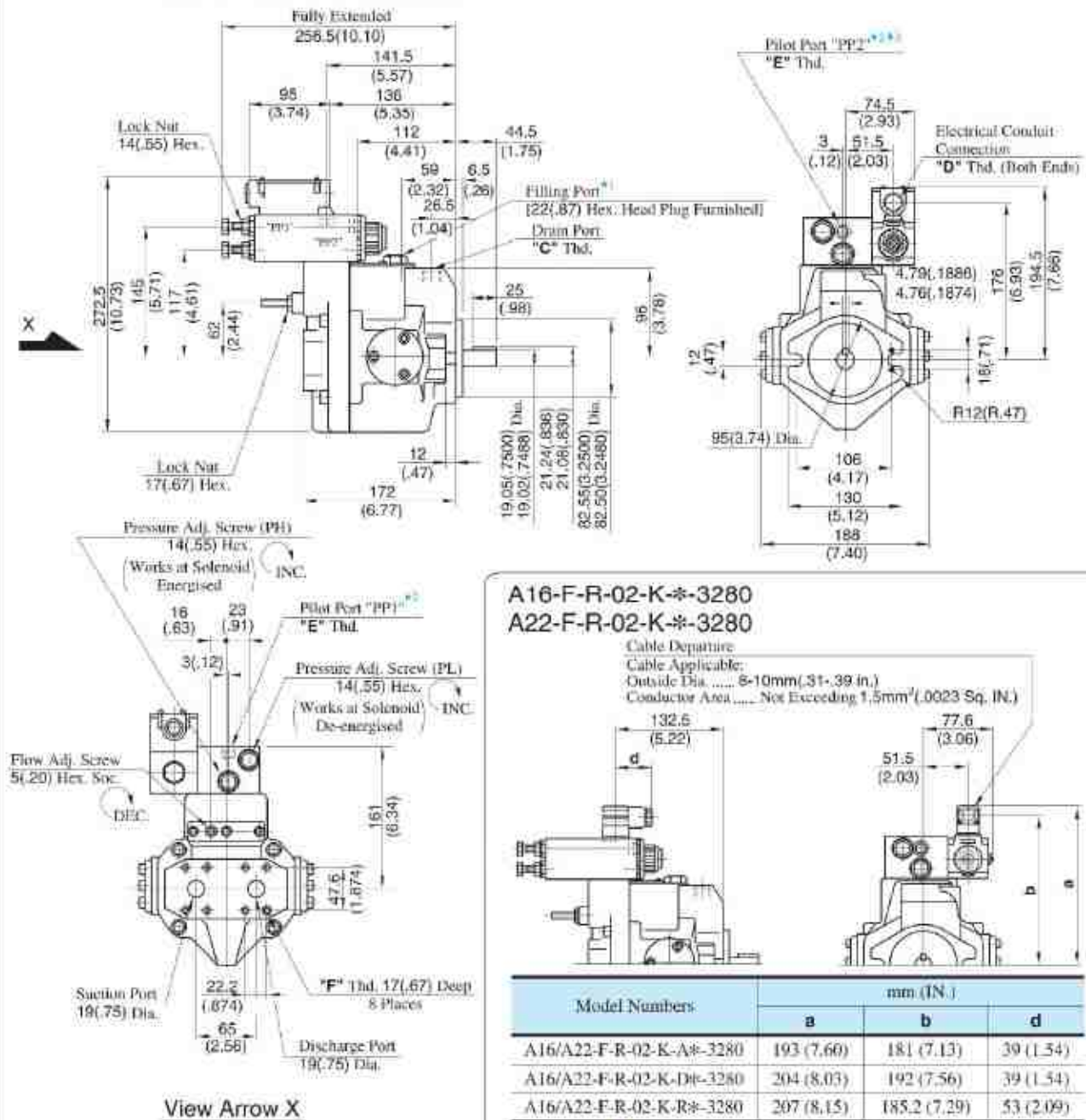

A16-F-R-02-K*-3280
 A22-F-R-02-K*-3280

Cable Departure
 Cable Applicable:
 Outside Dia. 6-10mm(.31-.39 in.)
 Conductor Area Not Exceeding 1.5mm² (.0023 Sq. IN.)

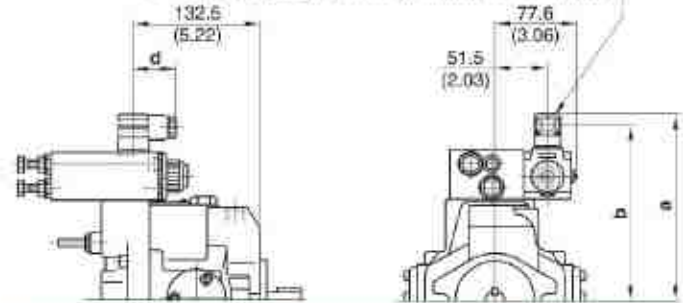

Model Numbers	mm (IN.)		
	a	b	d
A16/A22-F-R-02-K-A*-3280	193 (7.60)	181 (7.13)	39 (1.54)
A16/A22-F-R-02-K-D*-3280	204 (8.03)	192 (7.56)	39 (1.54)
A16/A22-F-R-02-K-R*-3280	207 (8.15)	185.2 (7.29)	53 (2.09)

* For other dimensions, refer to 32/32950 design.

- ★ 1. Install the pump so that the "Filling Port" is at the top.
- ★ 2. The pilot port provided is for connecting a control valve, if multistage pressure control is required.
- ★ 3. The pilot port "PP2" is not provided for N.American Design Standard.

Model Numbers	"C" Thd.	"D" Thd.	"E" Thd.	"F" Thd.
A16/A22-F-R-02-K*-32	Rc 3/8	G 1/2	Rc 1/4	M10
A16/A22-F-R-02-K*-3280	3/8 BSP F	—	1/4 BSP, Tr	
A16/A22-F-R-02-K*-32950	SAE #8	1/2 NPT	SAE #4	3/8-16 UNC

DIMENSIONS IN MILLIMETRES (INCHES)

Side Port Type

Port mounting dimensions are the same as those of pressure compensator model.
 Refer to page 45 for port mounting dimensions.

Foot Mounting Type

Mounting bracket is common to that of pressure compensator model.
 Refer to page 45 for the dimensions of mounting bracket.

Side Port Type

Flange Mtg. : A37-F-R-02-S-K-#-32/32950

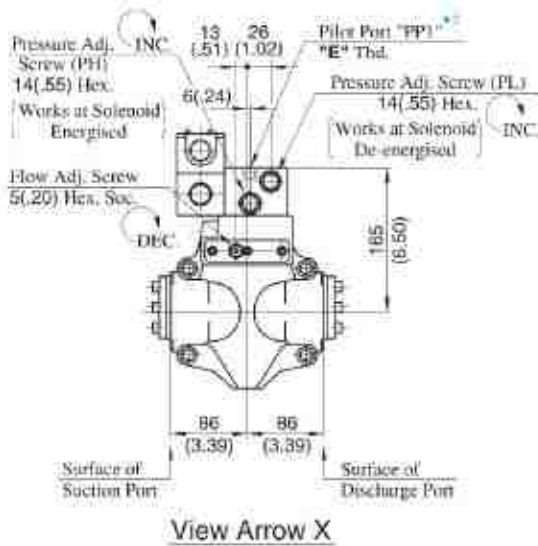
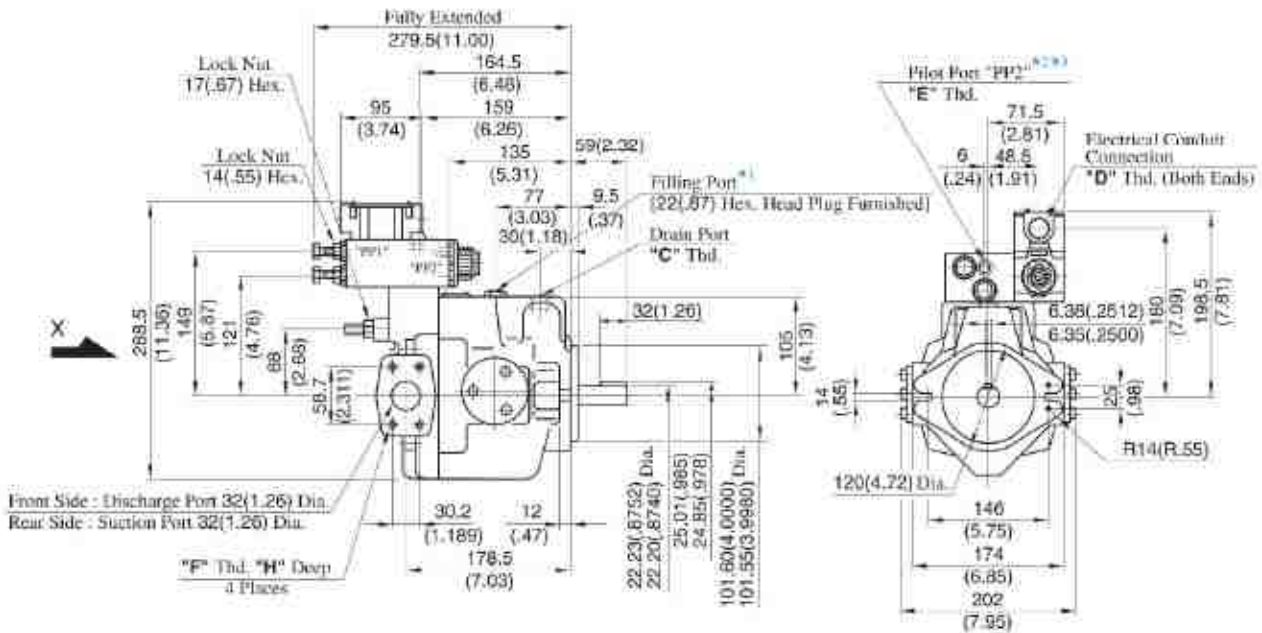

A37-F-R-02-S-K-#-3280

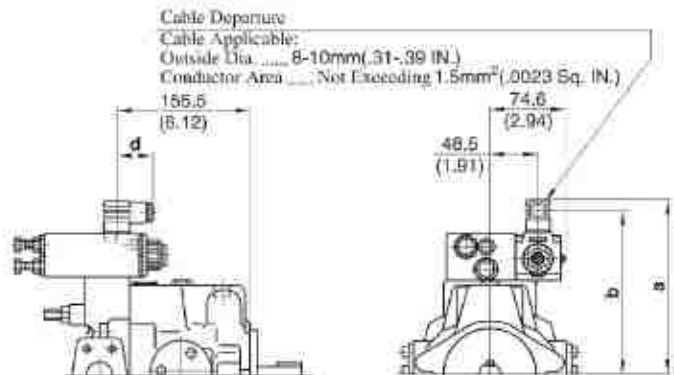

Model Numbers	mm (IN.)		
	a	b	d
A37-F-R-02-S-K-A#-3280	197 (7.76)	185 (7.28)	39 (1.54)
A37-F-R-02-S-K-D#-3280	208 (8.19)	196 (7.72)	39 (1.54)
A37-F-R-02-S-K-R#-3280	211 (8.31)	189.2 (7.45)	53 (2.09)

• For other dimensions, refer to 32/32950 design.

Model Numbers	"C" Thd.	"D" Thd.	"E" Thd.	"F" Thd.	"H" mm (IN.)
A37-F-R-02-S-K-#-32	Re 1/2	G 1/2	Re 1/4	M10	19 (.75)
A37-F-R-02-S-K-#-3280	1/2 BSP.F	—	1/4 BSP. Tr		
A37-F-R-02-S-K-#-32950	SAE #10	1/2 NPT	SAE #4	7/16-14 UNC	20 (.79)

DIMENSIONS IN MILLIMETRES (INCHES)

• **Axial Port Type**

Port mounting dimensions are the same as those of pressure compensator model.
 Refer to page 46 for port mounting dimensions.

• **Foot Mounting Type**

Mounting bracket is common to that of pressure compensator model.
 Refer to page 46 for the dimensions of mounting bracket.

Side Port Type

Flange Mtg.: A56-F-R-02-S-K-32/32950

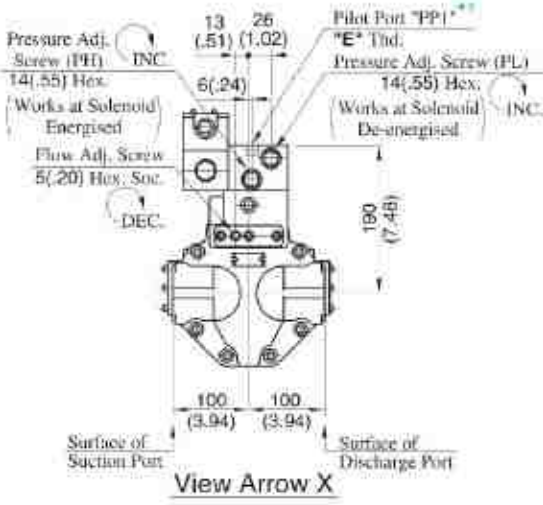
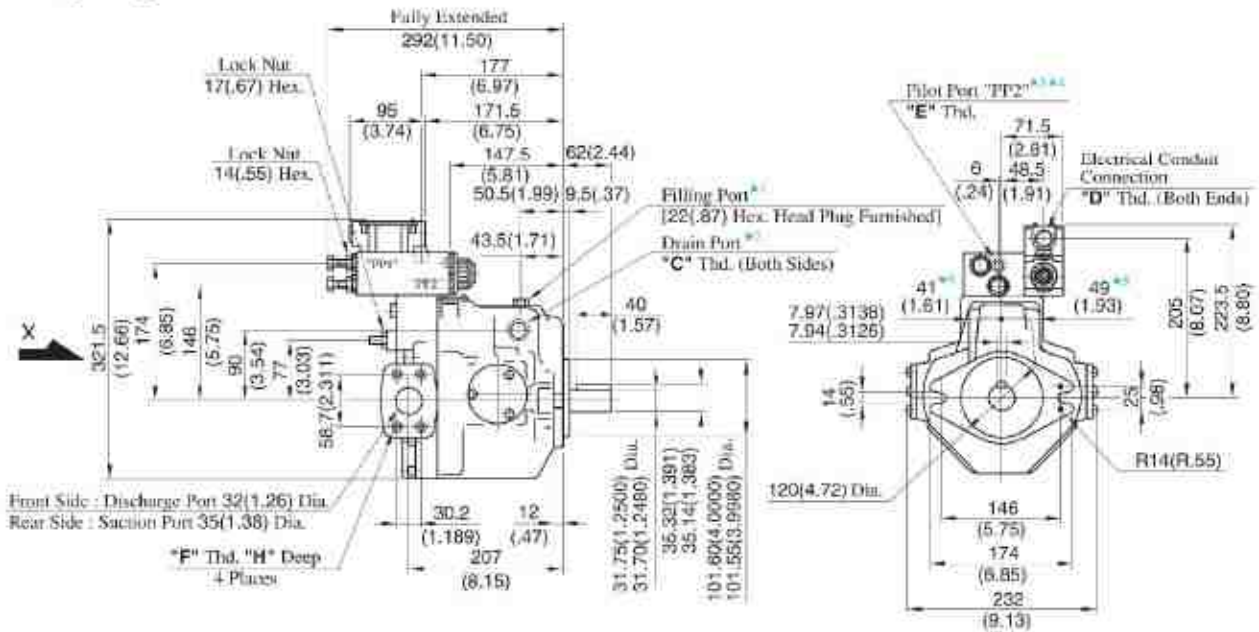

A56-F-R-02-S-K-3280

Cable Departure
 Cable Applicable:
 Outside Dia. 8-10mm(.31-.39 IN.)
 Conductor Area Not Exceeding 1.5mm²(.0023 Sq. IN.)

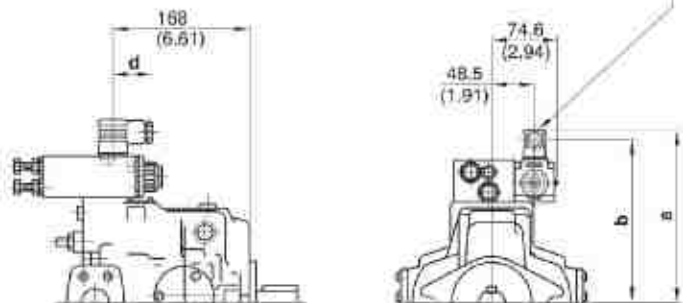

Model Numbers	mm (IN.)		
	a	b	d
A56-F-R-02-S-K-A-3280	222 (8.74)	210 (8.27)	39 (1.54)
A56-F-R-02-S-K-D-3280	233 (9.17)	221 (8.70)	39 (1.54)
A50-F-R-02-S-K-R-3280	236 (9.29)	214.2 (8.43)	23 (0.91)

* For other dimensions, refer to 32/32950 design.

- ★ 1. Install the pump so that the "Filling Port" is at the top.
- ★ 2. Use either port of two drain ports at your option. Keep the remaining port plugged.
- ★ 3. The pilot port provided is for connecting a control valve, if multistage pressure control is required.
- ★ 4. The pilot port "PP2" is not provided for N.American Design Standard.
- ★ 5. Dimensions show surface of drain port.

Model Numbers	*C* Thd.	*D* Thd.	*E* Thd.	*F* Thd.	*H* mm (IN.)
A56-F-R-02-S-K-32	Rc 3/4	G 1/2	Rc 1/4		
A56-F-R-02-S-K-3280	3/4 BSP.F	—	1/4 BSP. Tr	M10	19 (.75)
A56-F-R-02-S-K-32950	SAE #12	1/2 NPT	SAE #4	7/16-14 UNC	20 (.79)

DIMENSIONS IN MILLIMETRES (INCHES)

● Axial Port Type

Port mounting dimensions are the same as those of pressure compensator model.
 Refer to page 47 for port mounting dimensions.

● Foot Mounting Type

Mounting bracket is common to that of pressure compensator model.
 Refer to page 47 for the dimensions of mounting bracket.

Flange Mtg. : A70-FR02S*-60/60950

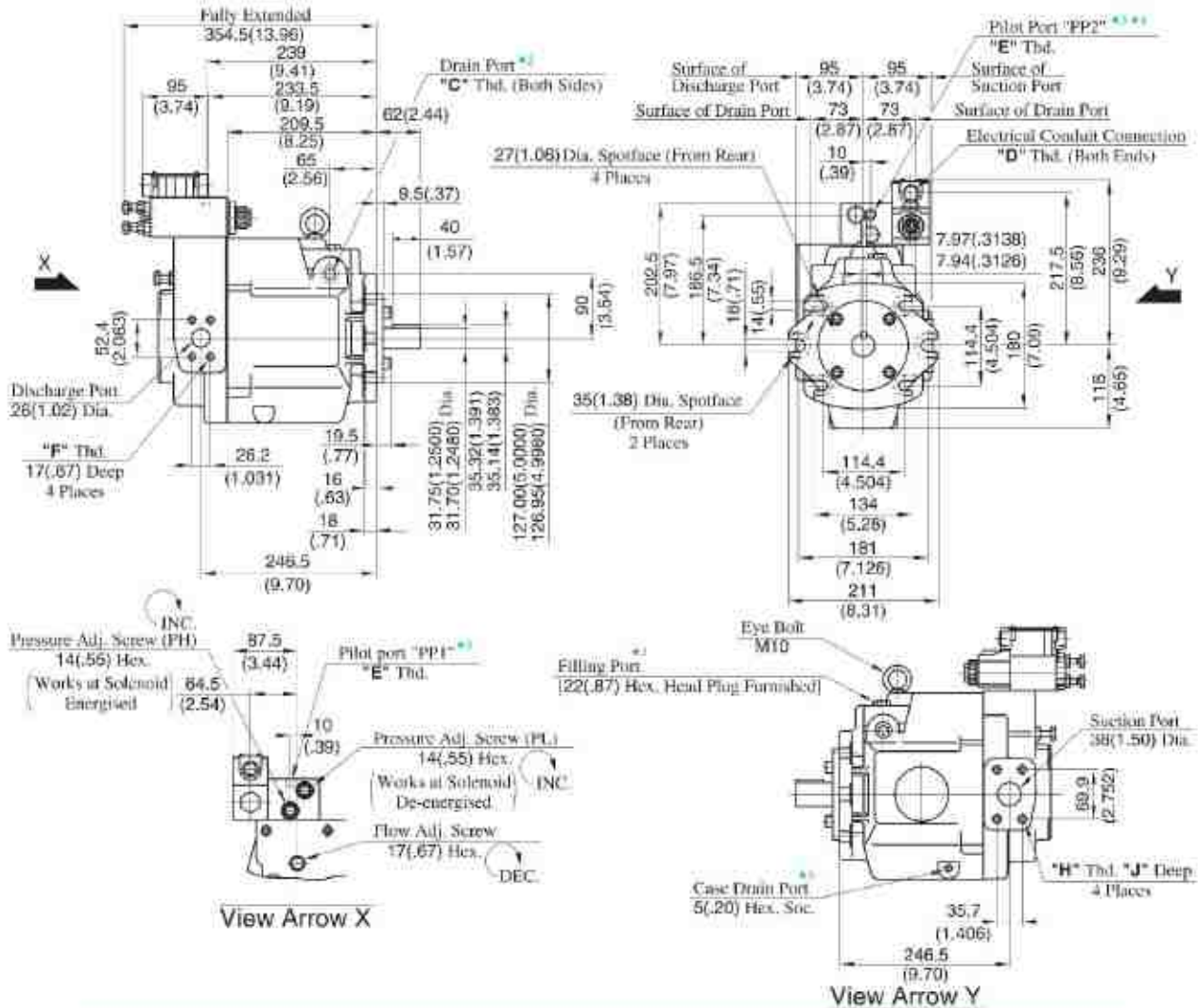

Model Numbers	"C" Thd.	"D" Thd.	"E" Thd.	"F" Thd.	"H" Thd.	"J" mm (IN.)
A70-FR02S*-60	Rc 3/4	G 1/2	Rc 1/4	M10	M12	19 (.75)
A70-FR02S*-6080	3/4 BSP.F	—	1/4 BSP.T			
A70-FR02S*-60950	SAE #12	1/2 NPT	SAE #4	7/16-14 UNC	1/2-13 UNC	21 (.83)

A70-FR02S*-6080

Cable Departure
 Cable Applicable:
 Outside Dia. 8-10mm (.31-.39 IN.)
 Conductor Area Not Exceeding 1.5mm² (.0023 Sq. IN.)

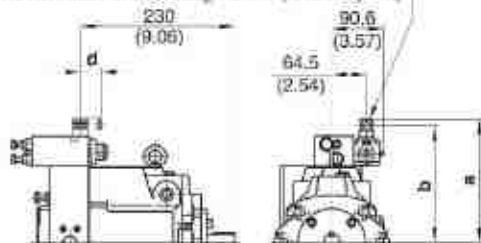

Model Numbers	mm (IN.)		
	a	b	d
A70-FR02SA*-6080	235 (9.25)	223 (8.78)	39 (1.54)
A70-FR02SD*-6080	246 (9.69)	234 (9.21)	39 (1.54)
A70-FR02SR*-6080	249 (9.80)	227.2 (8.94)	53 (2.09)

* For other dimensions, refer to 60/60950 design.

- ★ 1. Install the pump so that the "Filling Port" is at the top.
- ★ 2. Use either port of two drain ports at your option. Keep the remaining port plugged.
- ★ 3. The pilot port provided is for connecting a control valve, if multistage pressure control is required.
- ★ 4. The pilot port "PP2" is not provided for N.American Design Standard.
- ★ 5. Case drain port is available for use when draining hydraulic fluid from pump casing.

DIMENSIONS IN
MILLIMETRES (INCHES)

● **Foot Mounting Type**

Mounting bracket is common to that of pressure compensator model. Refer to page 48 for the dimensions of mounting bracket.

Flange Mtg.: A90-FR02S*-60/60950

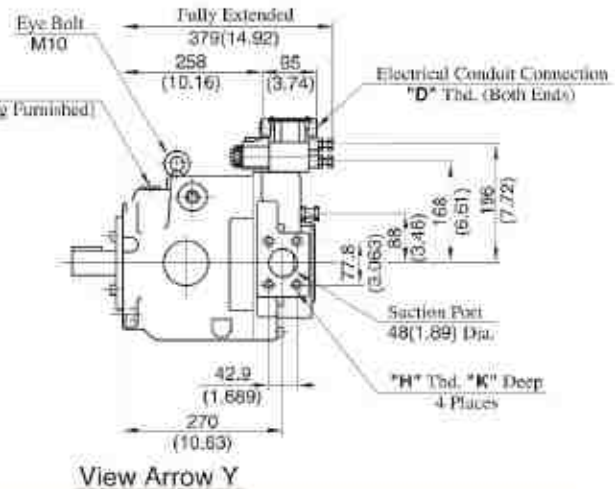
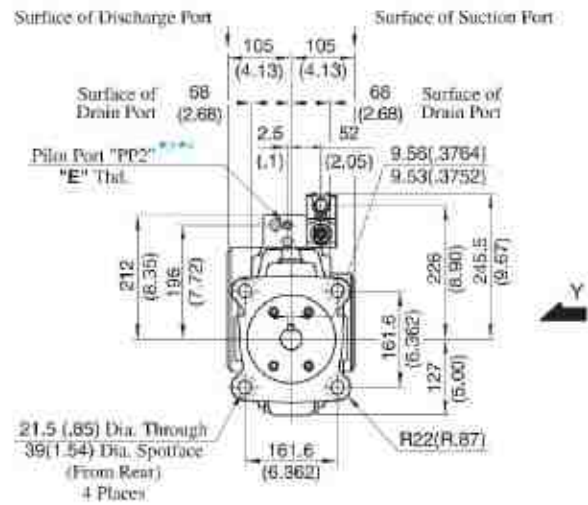
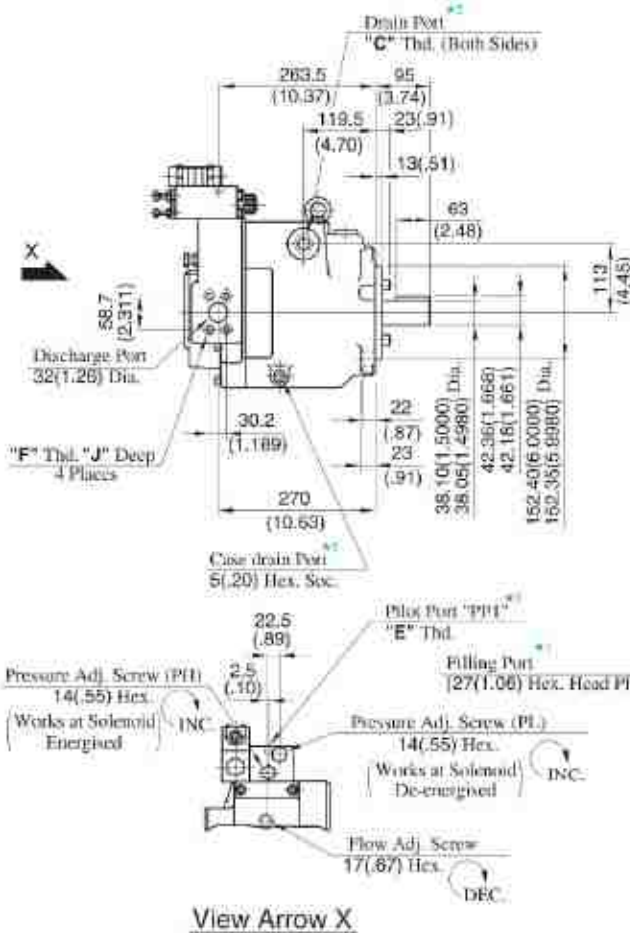

Model Numbers	"C" Thd.	"D" Thd.	"E" Thd.	"F" Thd.	"H" Thd.	"J" mm (IN.)	"K" mm (IN.)
A90-FR02S*-60	Re 3/4	G 1/2	Re 1/4	M10	M12	19 (.75)	19 (.75)
A90-FR02S*-6080	3/4 BSP.F		1/4 BSP. Tr				
A90-FR02S*-60950	SAE #12	1/2 NPT	SAE #4	7/16-14 UNC	1/2-13 UNC	20 (.79)	21 (.83)

A90-FR02S*-6080

Cable Departure
 Cable Applicable:
 Outside Dia. 8-10mm (.31-.39 IN.)
 Conductor Area Not Exceeding 1.5mm² (.0023 Sq. IN.)

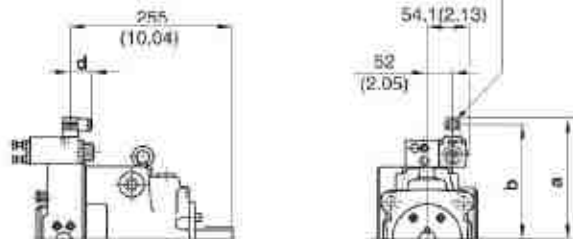

Model Numbers	mm (IN.)		
	a	b	d
A90-02FRSA*-6080	244 (9.61)	232 (9.13)	39 (1.54)
A90-02FRSD*-6080	255 (10.04)	243 (9.57)	39 (1.54)
A90-02FRSR*-6080	258 (10.16)	236.2 (9.30)	53 (2.09)

* For other dimensions, refer to 60/60950 design.

- ★ 1. Install the pump so that the "Filling Port" is at the top.
- ★ 2. Use either port of two drain ports at your option. Keep the remaining port plugged.
- ★ 3. The pilot port provided is for connecting a control valve, if multistage pressure control is required.
- ★ 4. The pilot port "PP2" is not provided for N.American Design Standard.
- ★ 5. Case drain port is available for use when draining hydraulic fluid from pump casing.

DIMENSIONS IN MILLIMETRES (INCHES)

• Foot Mounting Type

Mounting bracket is common to that of pressure compensator model. Refer to page 49 for the dimensions of mounting bracket.

Flange Mtg. : A145-FR02S*-60/60950

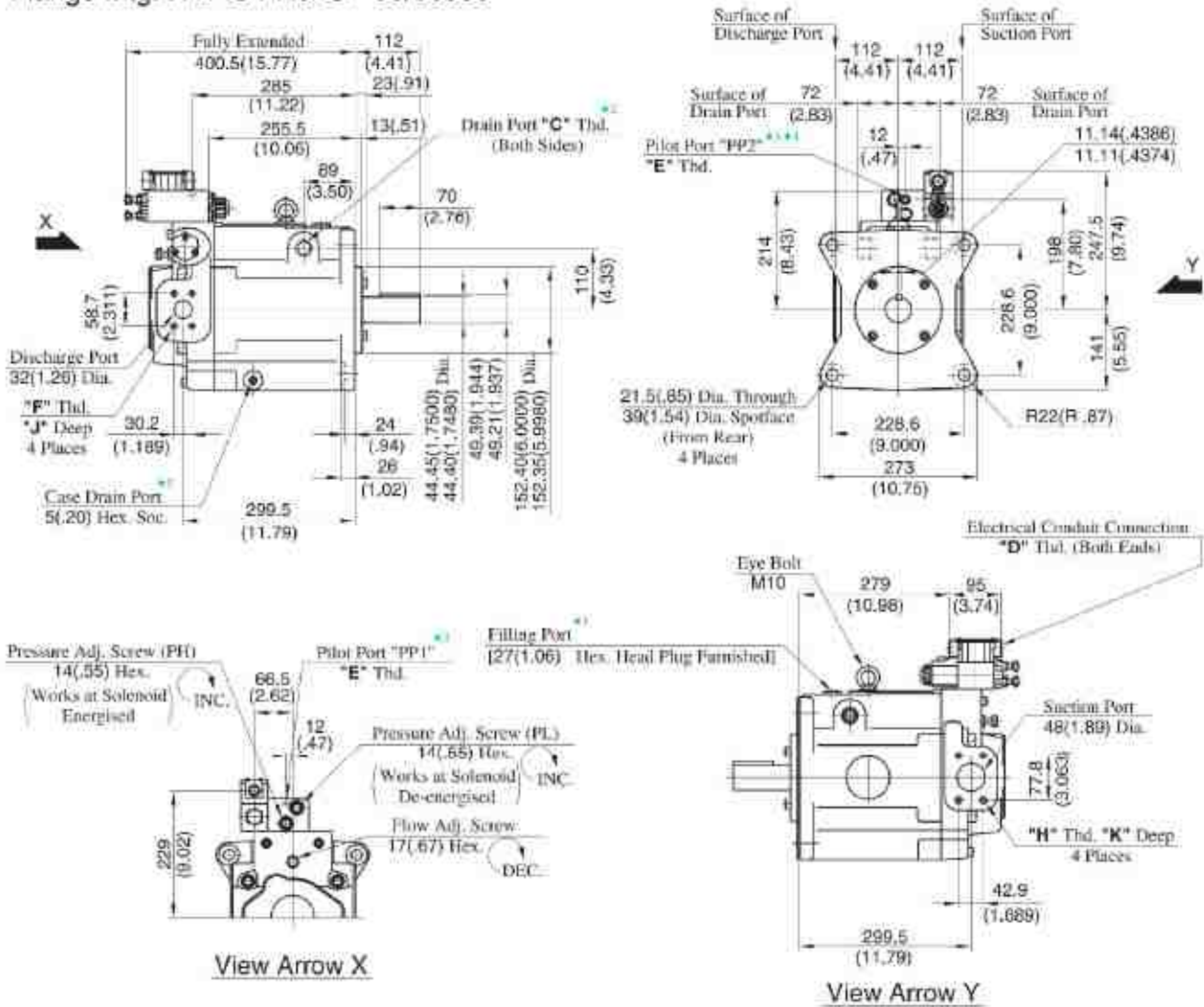

Model Numbers	"C" Thd.	"D" Thd.	"E" Thd.	"F" Thd.	"H" Thd.	"J" mm (IN.)	"K" mm (IN.)
A145-FR02S*-60	Rc 3/4	G 1/2	Rc 1/4	M10	M12	19 (.75)	19 (.75)
A145-FR02S*-6080	3/4 BSP.F	—	1/4 BSP. Tr				
A145-FR02S*-60950	SAE #12	1/2 NPT	SAE #4	7/16-14 UNC	1/2-13 UNC	20 (.79)	21 (.83)

A145-FR02S*-6080

Cable Departure
 Cable Applicable:
 Outside Dia. 8-10mm(.31-.39 IN.)
 Conductor Area Not Exceeding 1.5mm²(.0023 Sq. IN.)



Model Numbers	mm (IN.)		
	a	b	d
A145-FR02SA*-6080	246 (9.69)	234 (9.21)	39 (1.54)
A145-FR02SD*-6080	257 (10.12)	245 (9.65)	39 (1.54)
A145-FR02SR*-6080	260 (10.24)	238.2 (9.38)	53 (2.09)

* For other dimensions, refer to 60/60950 design.

- ★ 1. Install the pump so that the "Filling Port" is at the top.
- ★ 2. Use either port of two drain ports at your option. Keep the remaining port plugged.
- ★ 3. The pilot port provided is for connecting a control valve, if multistage pressure control is required.
- ★ 4. The pilot port "PP2" is not provided for N.American Design Standard.
- ★ 5. Case drain port is available for use when draining hydraulic fluid from pump casing.

DIMENSIONS IN MILLIMETRES (INCHES)

● **Foot Mounting Type**

Mounting bracket is common to that of pressure compensator model. Refer to page 50 for the dimensions of mounting bracket.



"A" Series Variable Displacement Piston Pumps – Single Pump, Pressure Compensator with Unloading Type

Graphic Symbol

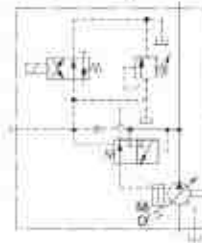

Performance Characteristics

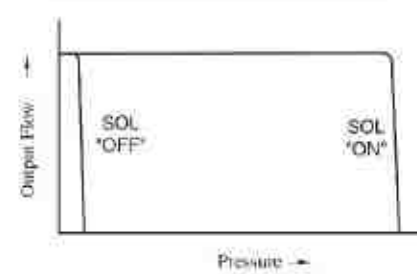

Specifications

Model Numbers	Geometric Displacement cm ³ /rev (cu. in./rev)	Minimum Adj. Flow cm ³ /rev (cu. in./rev)	Operating Pressure MPa (PSI)		Unloading Pressure MPa (PSI)	Shaft Speed Range r/min	
			Rated	Intermittent		Max.	Min.
A16*-R-03*-K*-32*	15.8 (.964)	4 (.244)	16 (2320)	21 (3050)	1.2 (170)	1800	600
A22*-R-03*-K*-32*	22.2 (1,355)	6 (.366)	16 (2320)	16 (2320)	1.2 (170)	1800	600
A37*-R-03*-K*-32*	36.9 (2.25)	10 (.61)	16 (2320)	21 (3050)	1.2 (170)	1800	600
A56*-R-03*-K*-32*	56.2 (3.43)	12 (.73)	16 (2320)	21 (3050)	1.2 (170)	1800	600
A70*-R03S*-60*	70.0 (4.27)	30 (1.83)	25 (3630)	25 (3630)	1.2 (170)	1800	600
A90 *R03S* 60*	91.0 (5.55)	56 (3.42)	25 (3630)	25 (3630)	1.2 (170)	1800	600
A145*-R03S*-60*	145 (8.85)	83 (5.06)	25 (3630)	25 (3630)	1.2 (170)	1800	600

Model Number Designation

A16	-F	-R	-03	-S	-K	-A100	-32	*
Series Number	Mounting	Direction of Rotation	Control Type	Port Position	Shaft Extension	Coil Type of Solenoid Valve	Design Number	Design Std.
A16 (15.8 cm ³ /rev)	F: Flange Mtg.	(Viewed from Shaft End) R: Clockwise (Normal)	03: Pressure Compensator with Unloading Type	None: Axial Port S: Side Port	K: Keyed Shaft	AC A100,A120 A200,A240 DC D12,D24 D48 R(AC→DC Rectified) R100,R200	32	Refer to *2
A22 (22.2 cm ³ /rev)							32	
A37 (36.9 cm ³ /rev)							32	
A56 (56.2 cm ³ /rev)							32	

A70	-F	R	03	S	A100	-60	*
Series Number	Mounting	Direction of Rotation	Control Type	Port Position	Coil Type of Solenoid Valve	Design Number	Design Std.
A70 (70.0 cm ³ /rev)	F: Flange Mtg. L: Foot Mtg.	(Viewed from Shaft End) R: Clockwise (Normal)	03: Pressure Compensator with Unloading Type	S: Side Port	AC A100,A120 A200,A240 DC D12,D24 D48 R(AC→DC Rectified) R100,R200	60	Refer to *2
A90 (91.0 cm ³ /rev)						60	
A145 (145 cm ³ /rev)						60	

*1 Available to supply pump with anti-clockwise rotation. Consult Yuken for details.

*2 Design Standards: None Japanese Standard "JIS"
 80 European Design Standard
 950 N. American Design Standard

Consult Yuken when detailed material such as dimensions figures is required.

"A" Series Variable Displacement Piston Pumps – Single Pump, Proportional Electro-Hydraulic Load Sensing Type



Performance Characteristics

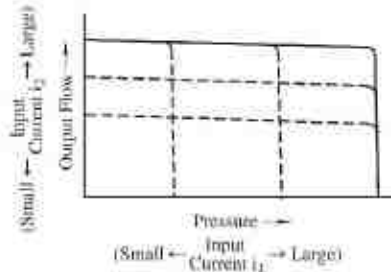

Graphic Symbols

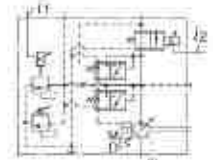

A16/A22/A37/A56

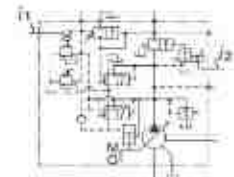

A70/A90/A145

Model Number Designation

A56	-F	-R	-04	-C	-K	-32	*
Series Number	Mounting	Direction of Rotation	Control Type	Pressure Adj. Range MPa (PSI)	Shaft Extension	Design Number	Design Std.
A16 (15.8 cm ³ /rev)	F: Flange Mtg. L: Foot Mtg.	(Viewed from) Shaft End R: Clockwise *1	04: Proportional Electro-Hydraulic Load Sensing Type	B: 1.5 - 6.9 (220 - 1000) C: 1.5 - 15.7 (220 - 2280) H: 1.5 - 20.6 (220 - 2990)	K: Keyed Shaft	32	Refer to *2
A22 (22.2 cm ³ /rev)				B: 1.5 - 6.9 (220 - 1000) C: 1.5 - 15.7 (220 - 2280)		32	
A37 (36.9 cm ³ /rev)				B: 2 - 6.9 (290 - 1000) C: 2 - 15.7 (290 - 2280) H: 2 - 20.6 (290 - 2990)		32	
A56 (56.2 cm ³ /rev)				32			

A70	-F	R	04	C	S	-60	*
Series Number	Mounting	Direction of Rotation	Control Type	Pressure Adj. Range MPa (PSI)	Port Position	Design Number	Design Std.
A70 (70.0 cm ³ /rev)	F: Flange Mtg. L: Foot Mtg.	(Viewed from) Shaft End R: Clockwise *1	04: Proportional Electro-Hydraulic Load Sensing Type	C: 1.5 - 16 (220 - 2320) H: 1.5 - 21 (220 - 3050)	S: Side Port	60	Refer to *2
A90 (91.0 cm ³ /rev)						60	
A145 (145 cm ³ /rev)						60	

*1. Available to supply pump with anti-clockwise rotation. Consult Yuken for details.

*2. Design Standards: None Japanese Standard "JIS"
 80 European Design Standard

• Consult Yuken when "N. American Design Standard" is required.



■ Pipe Flange Kits

Pipe flange kits are available.
 When ordering, specify the kit number from the table below.

Pump Model Numbers	Name of Port	Pipe Flange Kit Numbers			
		Threaded Connection		Socket Welding ^{*1}	Butt Welding
		Japanese Standard "JIS"	European Design Standard	Japanese Standard "JIS" & European Design Standard	Japanese Standard "JIS" & European Design Standard
A16-#-R-04 A22-#-R-04	Suction	F5-06-A-10	F5-06-A-1080	F5-06-B-10	F5-06-C-10
	Discharge	—*2	—*2	—*2	—*2
A37-#-R-04 A56-#-R-04	Suction	F5-10-A-10	F5-10-A-1080	F5-10-B-10	F5-10-C-10
	Discharge	F5-06-A-10	F5-06-A-1080	F5-06-B-10	F5-06-C-10
A70-#R04	Suction	F5-12-A-10	F5-12-A-1080	F5-12-B-10	F5-12-C-10
	Discharge	F5-10-A-10	F5-10-A-1080	F5-10-B-10	F5-10-C-10
A90-#R04 A145-#R04	Suction	F5-16-A-10	F5-16-A-1080	F5-16-B-10	F5-16-C-10
	Discharge	F5-10-A-10	F5-10-A-1080	F5-10-B-10	F5-10-C-10

*1 In case of using socket welding flanges, there is a case where the operating pressure should be set lower than the normal because of strength of the flanges. Therefore, please pay cautious attention to the operating pressure when the socket welding flanges are used.

*2 Discharge port for pump model "A16" and "A22" is available only the threaded connections.

* Detail of the pipe flange kits are shown on page 824.

■ Instructions

● Bleeding Air

In order to get steadily controlled pressure and flow, bleed air by loosening the air vent screw and fill solenoid armature with operating oil.

● Manual Adjustment Screws

Manual adjustment screws may be used for initial running adjustment or in case of electrical failures in order to adjust pressure and flow temporarily. In case of normal use, put the manual adjustment screws back in their preset positions.

● Position of Cable Departure

Position of cable departure can be changed. For details, refer to EDG-01 valve on page 672.

● Connection of Surge Cut-off Valve to "A" Series Pump (For A16 to A56 Type)

If using surge cut-off valve (SF1105-A-10), connect between pilot port "PP" of this pump and port "PP" of surge cut-off valve as pilot piping (refer to drawing below).

Inside diameter of pipe should be more than 8 mm (.32 in.).

Consult Yuken of detail of surge cut-off valve.

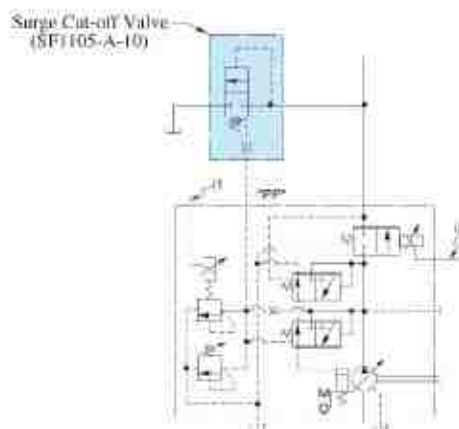

Specifications

Descriptions		Model No.	A16	A22	A37	A56	A70	A90	A145	
Geometric Displacement		cm ³ /rev (cu. in./rev)	15.8 (.964)	22.2 (1.355)	36.9 (2.25)	56.2 (3.43)	70.0 (4.27)	91.0 (5.55)	145 (8.85)	
Operating Pressure MPa (PSI)		Rated ^{★1}	16 (2320)	16 (2320)	16 (2320)	16 (2320)	21 (3050)	21 (3050)	21 (3050)	
		Intermittent ^{★1}	21 (3050)	16 (2320)	21 (3050)	21 (3050)	21 (3050)	21 (3050)	21 (3050)	
Shift Speed Range r/min		Max.	1800	1800	1800	1800	1800	1800	1800	
		Min.	600	600	600	600	600	600	600	
Flow Control		Flow Adj. Range	L/min (U.S. GPM)	1 - 28.4 (.26 - 7.5)	1 - 40 (.26 - 10.6)	1 - 66 (.26 - 17.4)	1 - 101 (.26 - 26.7)	1 - 126 (.26 - 33.3)	1 - 163 (.26 - 43.1)	2 - 261 (.53 - 69.0)
		Min Pres. Required for Flow Adj.	MPa (PSI)	1.5 (220)	1.5 (220)	1.5 (220)	2.0 (290)	1.0 (145)	1.0 (145)	1.0 (145)
		Differential Pres. (Discharge Pres. - Load Pres.)	MPa (PSI)	0.37 (55)			0.22 (30)			
		Step Response ^{★2} (0 → Max. Flow)	ms	70	80	120	125	100	120	210
		Hysteresis		3% or less ^{★3}						
		Rated Current	mA	900	700	740	790	820	920	920
		Coil Resistance [20°C (68°F)]		10						
Pres. Control		Pres. Adj. Range	MPa (PSI) Refer to Model Number Designation							
		Step Response ms	t ₁ ^{★4}	80	80	50	55	150	150	160
			t ₂ ^{★4}	140	90	80	80	80	120	180
		Hysteresis		2% or less ^{★3}						
		Rated Current	mA	(Pres. Adj. Range) B: 770, C: 880, H: 790				C: 860 H: 765	C: 873 H: 765	C: 875 H: 755
		Coil Resistance [20°C (68°F)]	Ω	10						
Applicable Amplifier Model ^{★5}		AME-D2-1010-φ-10								
Approx. Mass kg (lbs.)		Flange Mtg.	32 (70.6)	32 (70.6)	38 (83.8)	45 (99.2)	72.5 (160)	88.5 (195)	109.5 (241)	
		Foot Mtg.	34.2 (75.4)	34.2 (75.4)	43.2 (95.3)	49.3 (109)	84.5 (186)	109 (240)	134.5 (297)	

- ★1 Whenever setting pressure, make sure the full cut-off pressure never exceeds the maximum intermittent pressure.
- ★2 When operating the pump exceeding the rated pressure, operating conditions are restricted. Refer to page 33 for the details.
- ★3 For detail specifications of power amplifiers, refer to page 780.
- ★4 The figure mentioned in the above table are those obtained using Yuken's amplifier.
- ★5 Step response depends on circuit and operating conditions. Data shown in the table above is an example based on the condition right.

Model	Pres. Step Response		Loading Volume
	t ₁	t ₂	
A16, A22	1.5 → 16 MPa (220 → 2320 PSI)	16 → 1.5 MPa (2320 → 220 PSI)	High Pressure Hose 3/8" × 2 m (6.6 ft)
A37, A56	2.0 → 16 MPa (290 → 2320 PSI)	16 → 2.0 MPa (2320 → 290 PSI)	High Pressure Hose 3/4" × 2 m (6.6 ft)
A70, A90 A145	3.0 → 16 MPa (435 → 2320 PSI)	16 → 3.0 MPa (2320 → 435 PSI)	High Pressure Hose 1-1/4" × 2 m (6.6 ft)



Typical Performance Characteristics at Viscosity 20 mm²/s (100 SSU) [ISO VG32 Oils, 50°C (122°F)]

Full Cut-off Pres. vs. Input Current

• A16/A22/A37/A56

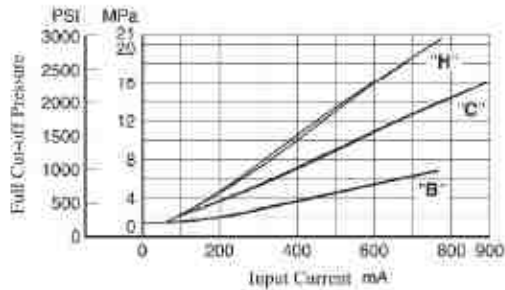

Note: Pressure adjustment range "H" is not available for A22.

• A70/A90/A145

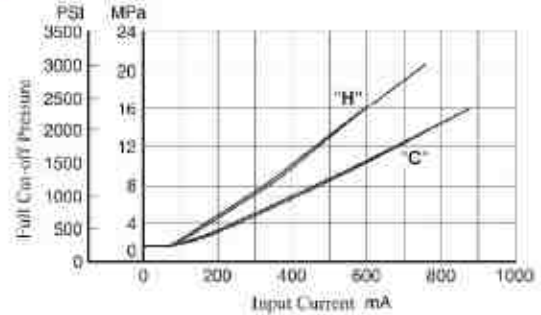

Output Flow vs. Input Current

• A16

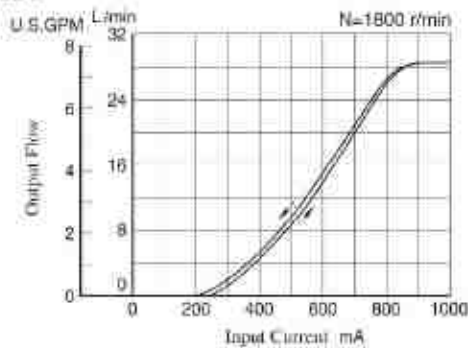

• A22

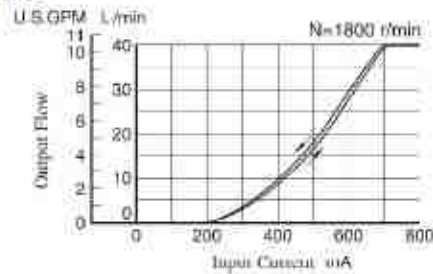

• A37

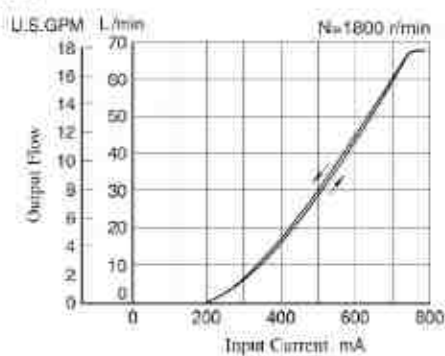

• A56

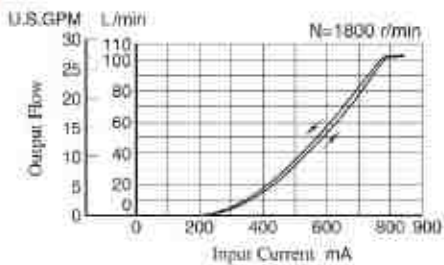

• A90

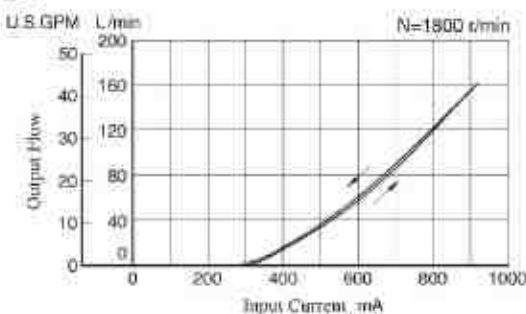

• A70

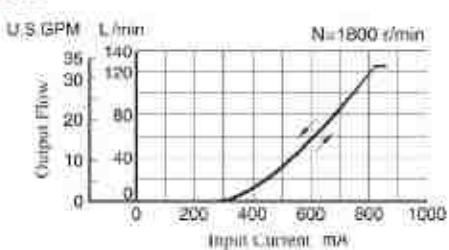

• A145

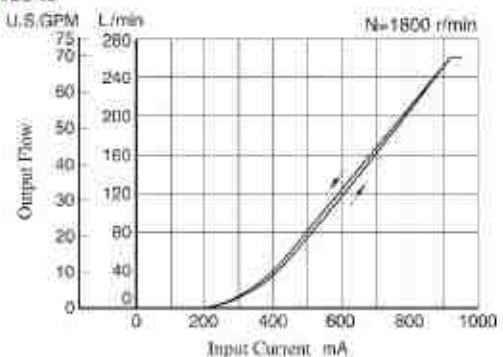

Flange Mtg. : A16-F-R-04-K-32/3280
 A22-F-R-04-K-32/3280

DIMENSIONS IN MILLIMETRES (INCHES)

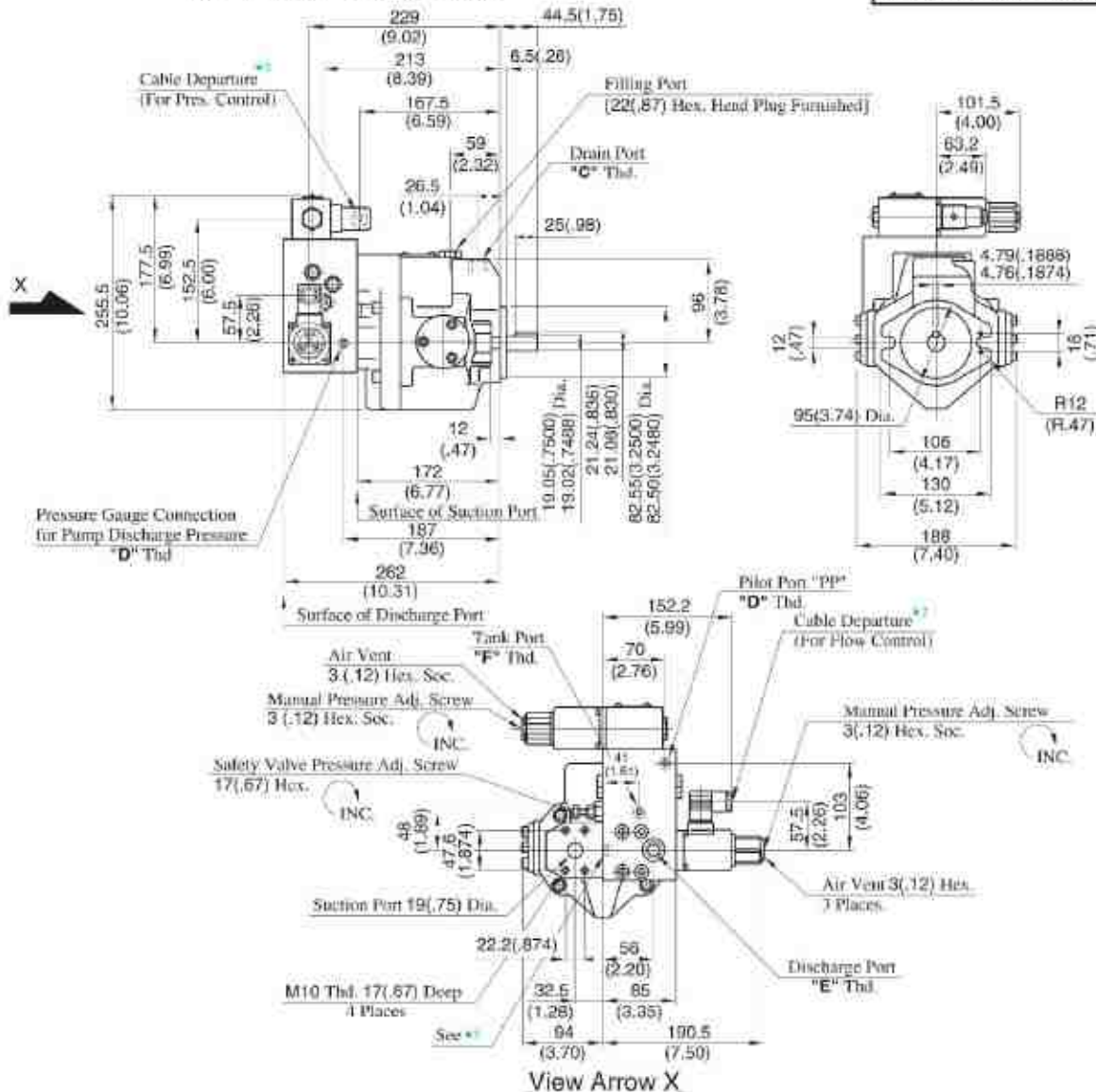

Model Numbers:	"C" Thd.	"D" Thd.	"E" Thd.	"F" Thd.
A16/A22-F-R-04-K-32	Re 3/8	Re 1/4	G 3/8*	Re 1/4
A16/A22-F-R-04-K-3280	3/8 BSP.F	1/4 BSP.Tr	3/8 BSP.F	1/4 BSP.F

★ 1. Detail of Discharge Port
 [For Japanese Standard]

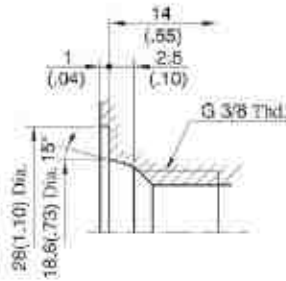

- ★ 2. Cable Applicable:
 Outside Dia.....8-10 mm (.31-.39 IN.)
 Conductor Area.....Not Exceeding 1.5 mm² (.0023 Sq. IN.)
- ★ 3. Do not touch the screw because it is adjusted at the time of shipment.

● Foot Mounting Type

Mounting bracket is common to that of pressure compensator model.
 Refer to page 45 for the dimensions of mounting bracket.

Flange Mtg. : A37-F-R-04- \ast -K-32/3280

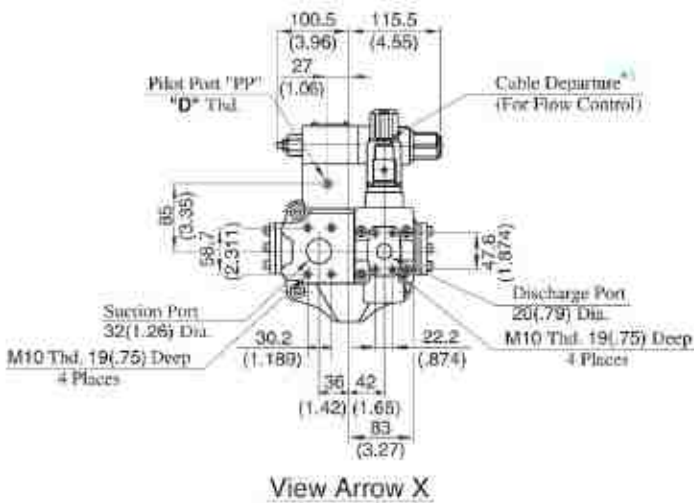
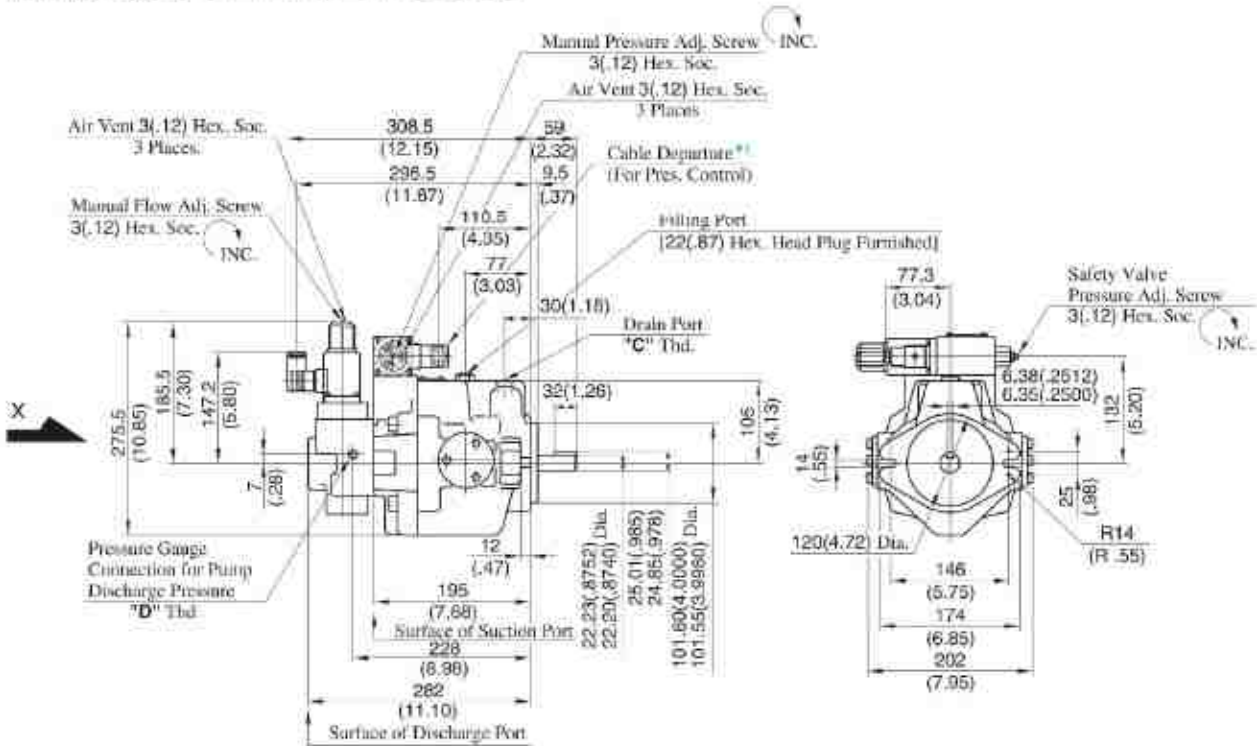

* 1. Cable Applicable:
 Outside Dia.....8-10 mm (.31-.39 IN.)
 Conductor Area.....Not Exceeding 1.5 mm² (.0023 Sq. IN.)

Model Numbers	"C" Thd.	"D" Thd.
A37-F-R-04- \ast -K-32	Re 1/2	Re 1/4
A37-F-R-04- \ast -K-3280	1/2 BSP.F	1/4 BSP.Tr

DIMENSIONS IN MILLIMETRES (INCHES)

Foot Mtg. : A37-L-R-04- \ast -K-32/3280

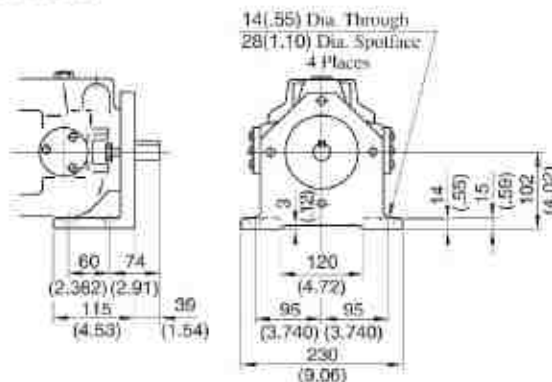

* For other dimensions, refer to "Flange Mtg.".

Flange Mtg. : A56-F-R-04- ϕ -K-32/3280

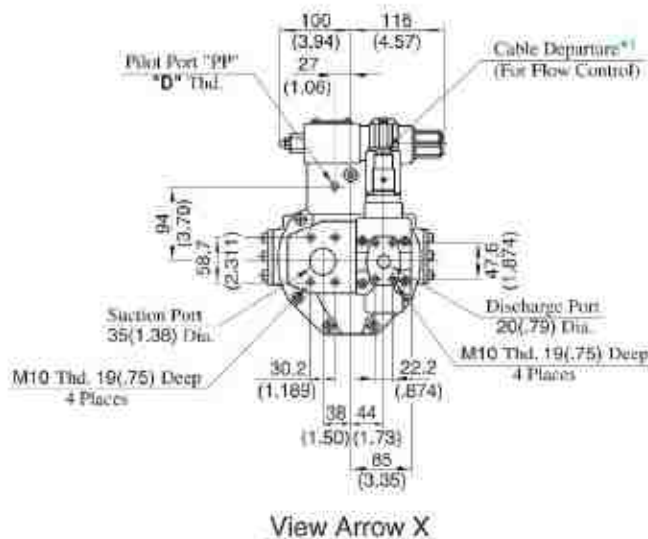
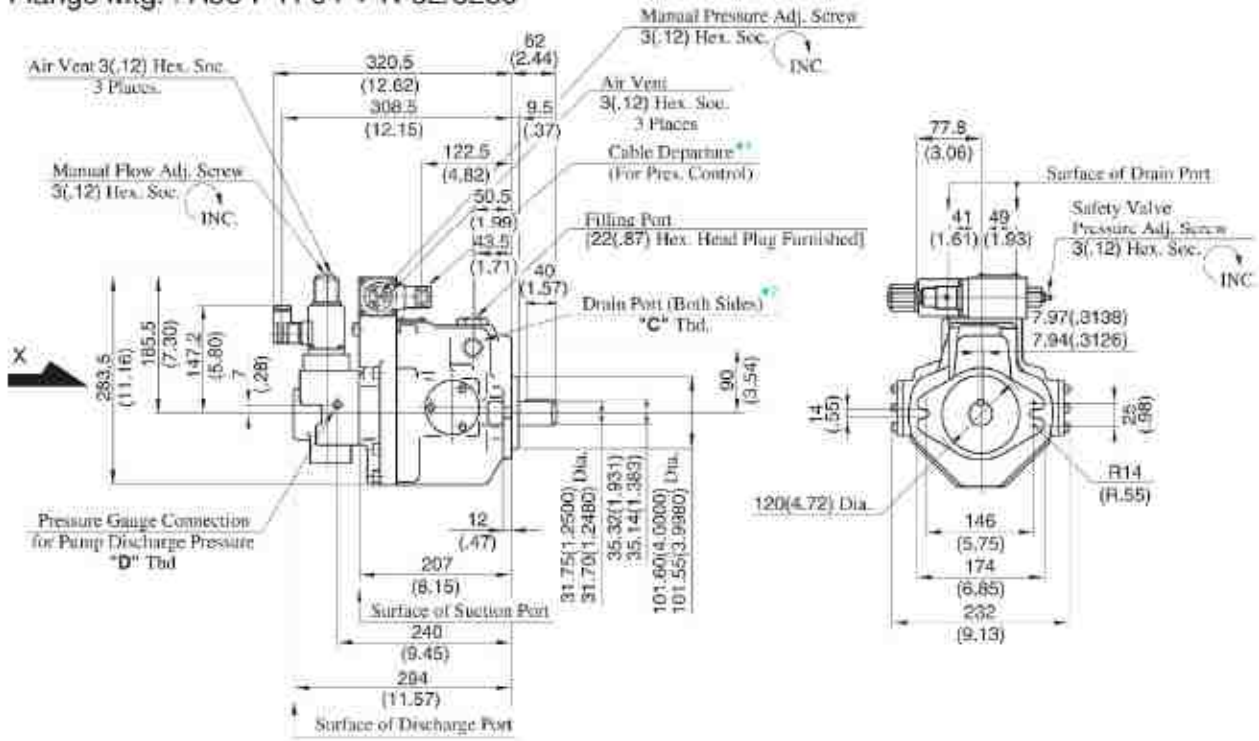

- ★ 1 Cable Applicable:
Outside Dia.....8-10 mm (.31-.39 IN.)
Conductor Area.....Not Exceeding 1.5 mm² (.0023 Sq. IN.)
- ★ 2 Use either port of two drain parts at your option.
Keep the remaining port plugged.

Model Numbers	"C" Thd.	"D" Thd.
A56-F-R-04- ϕ -K-32	Re 3/4	Re 1/4
A56-F-R-04- ϕ -K-3280	3/4 BSP.F	1/4 BSP.Tr

DIMENSIONS IN MILLIMETRES (INCHES)

Foot Mtg. : A56-L-R-01- ϕ -K-32/3280

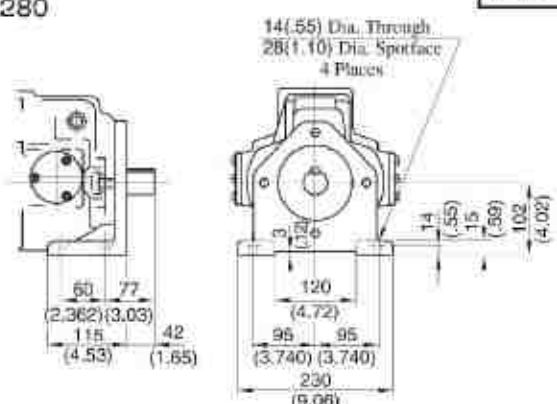

• For other dimensions, refer to "Flange Mtg."

Flange Mtg. : A70 FR04*S 60/6080

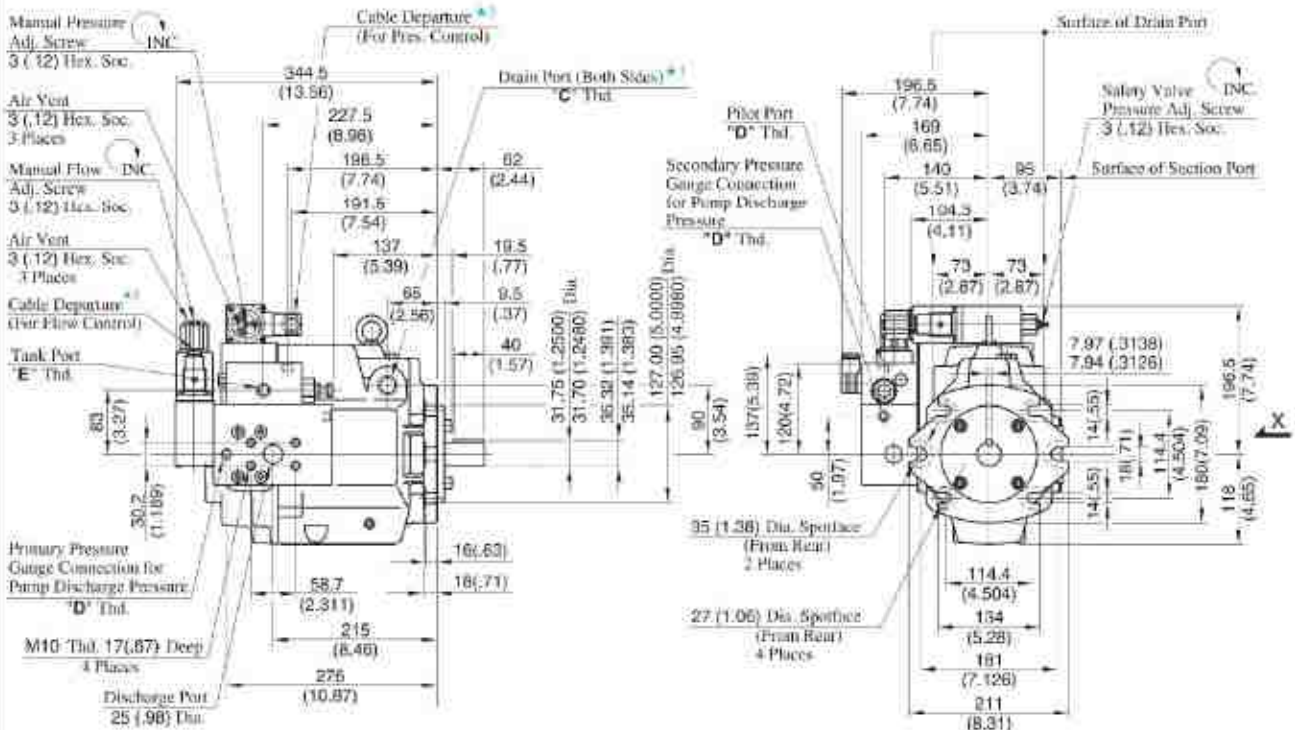

- ★ 1. Use either port of two drain ports at your option. Keep the remaining port plugged.
- ★ 2. Case drain port is available for use when draining hydraulic fluid from pump casing.
- ★ 3. Cable Applicable:
 Outside Dia.....8-10 mm (.31-.39 IN.)
 Conductor Area.....Not Exceeding 1.5 mm² (.0023 Sq. IN.)

Model Numbers	"C" Thd.	"D" Thd.	"E" Thd.
A70-FR04*S-60	Rc 3/4	Rc 1/4	Rc 3/8
A70-FR04*S-6080	3/4 BSP.F	1/4 BSP Tr	3/8 BSP.F

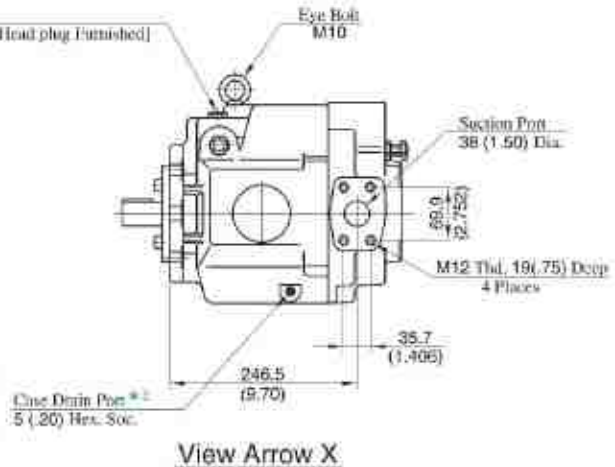

DIMENSIONS IN MILLIMETRES (INCHES)

Foot Mtg.: A70-LR04*S-60/6080

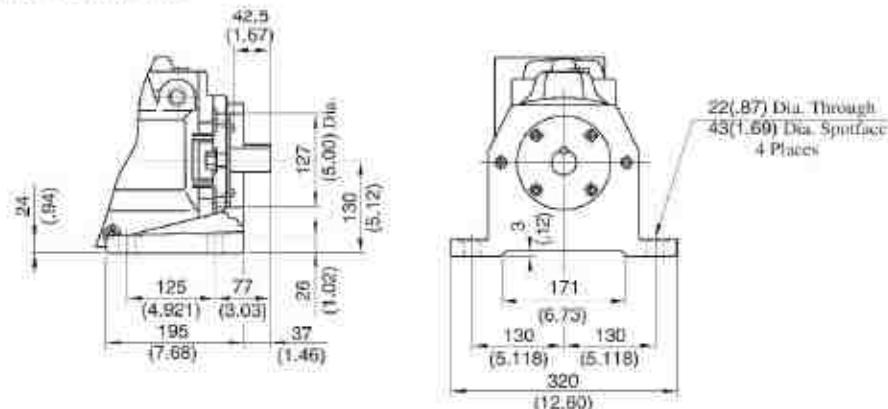

• For other dimensions, refer to "Flange Mtg."

Flange Mtg. : A90-FR04*S-60/6080

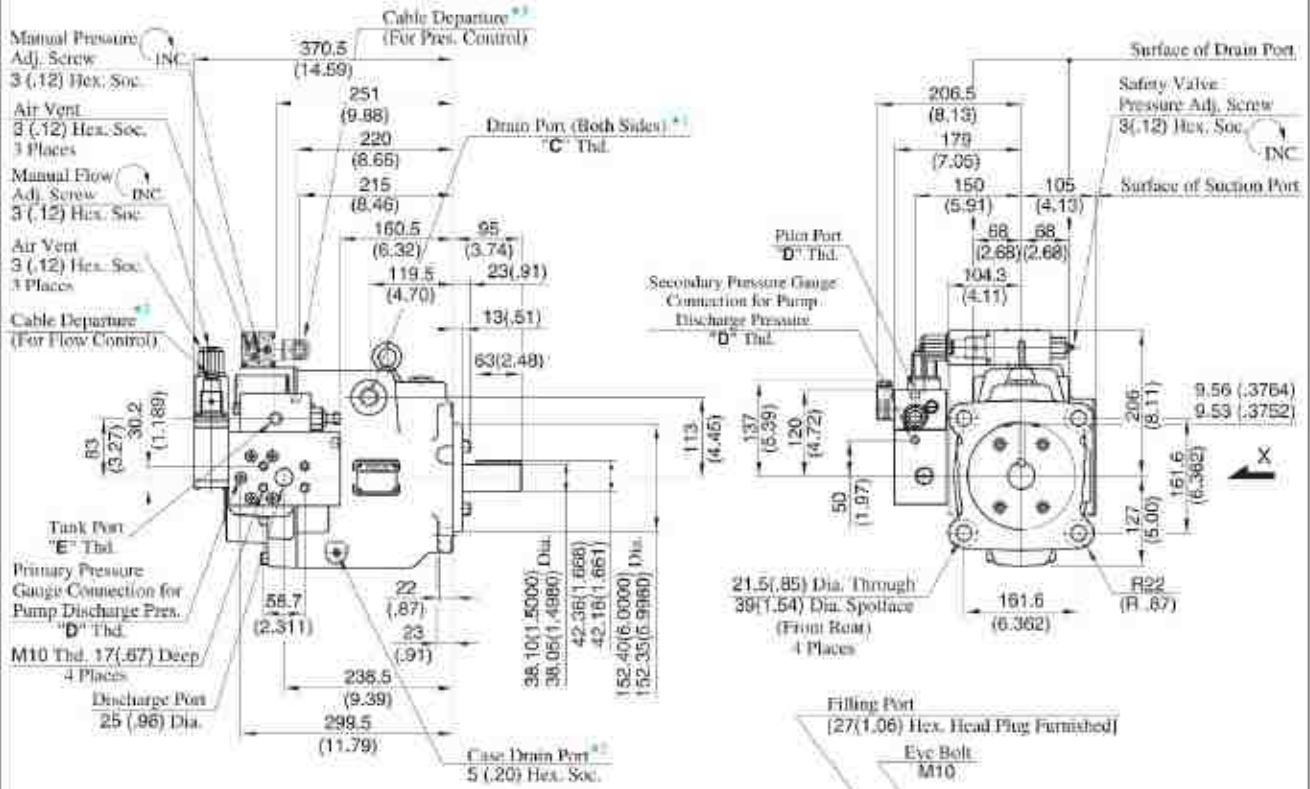

- ★ 1. Use either port of two drain ports at your option. Keep the remaining port plugged.
- ★ 2. Case drain port is available for use when draining hydraulic fluid from pump casing.
- ★ 3. Cable Applicable:
Outside Dia.....8-10 mm (.31-.39 IN.)
Conductor Area.....Not Exceeding 1.5 mm² (.0023 Sq. IN.)

Model Numbers	"C" Thd.	"D" Thd.	"E" Thd.
A90-FR04*S-60	Rc 3/4	Rc 1/4	Rc 3/8
A90-FR04*S-6080	3/4 BSP.F	1/4 BSP. Tr	3/8 BSP. F

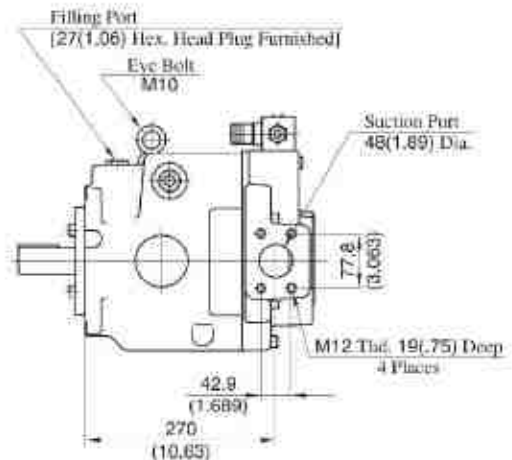

View Arrow X

DIMENSIONS IN MILLIMETRES (INCHES)

Foot Mtg. : A90-LR04*S-60/6080

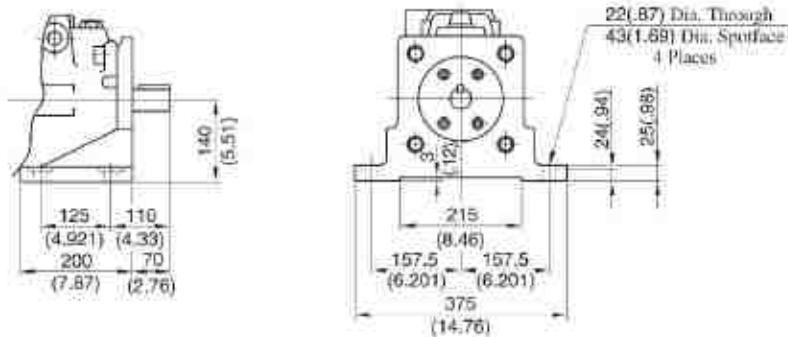

★ For other dimensions, refer to "Flange Mtg."

Flange Mtg. : A145-FR04*S-60/6080

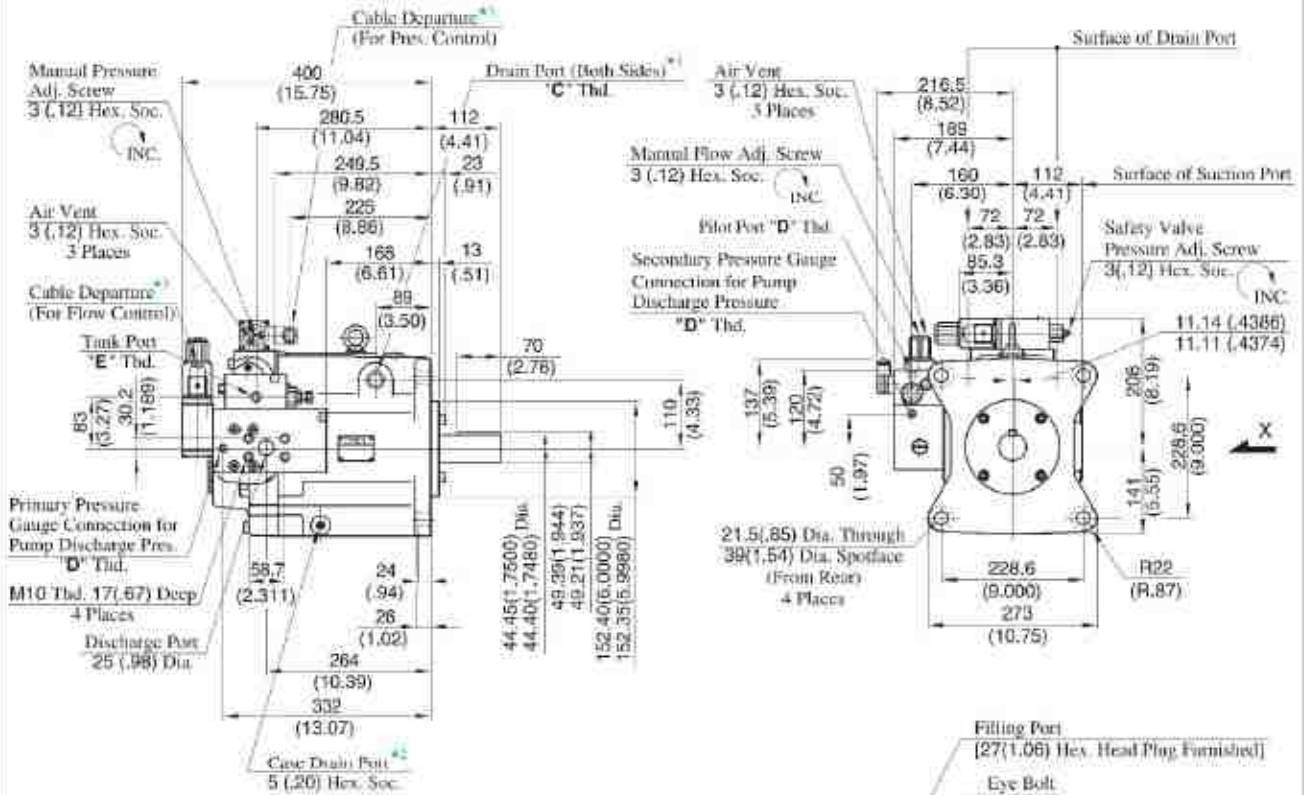

- ★ 1. Use either port of the two drain ports at your option. Keep the remaining port plugged.
- ★ 2. Case drain ports are available for use when draining hydraulic fluid from pump casing.
- ★ 3. Cable Applicable:
Outside Dia.....8-10 mm (.31-.39 IN.)
Conductor Area.....Not Exceeding 1.5 mm² (.0023 Sq. IN.)

Model Numbers	"C" Thd.	"D" Thd.	"E" Thd.
A145-FR04*S-60	Rc 3/4	Rc 1/4	Rc 3/8
A145-FR04*S-6080	3/4 BSP.F	1/4 BSP. Tr	3/8 BSP. F

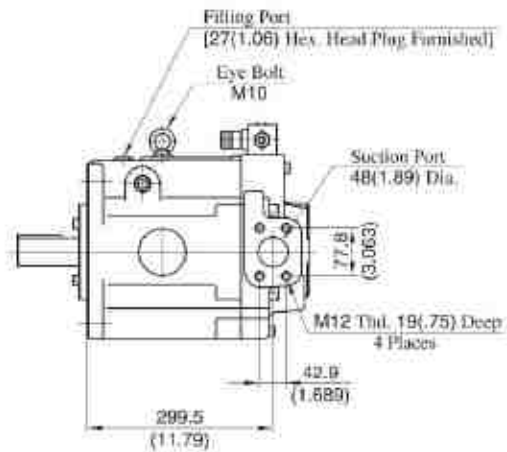

View Arrow X

DIMENSIONS IN MILLIMETRES (INCHES)

Foot Mtg.: A145-LR04*S-60/6080

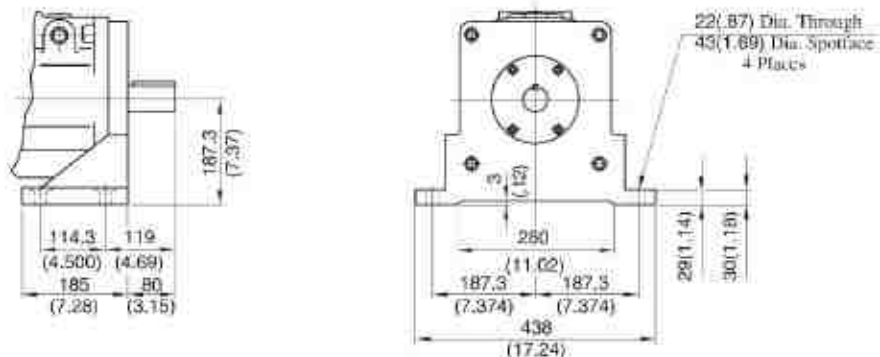

★ For other dimensions, refer to "Flange Mtg."

"A" Series Variable Displacement Piston Pumps – Single Pump, Electro-Hydraulic Proportional pressure & Flow Control Type

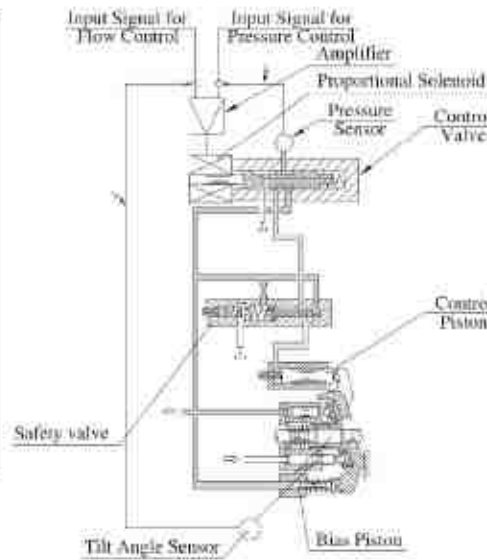

Performance Characteristics

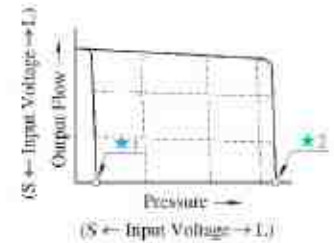

- ★ 1. Unloading pressure when input signal is 0 V.
- ★ 2. Safety valve setting pressure.

Graphic Symbols

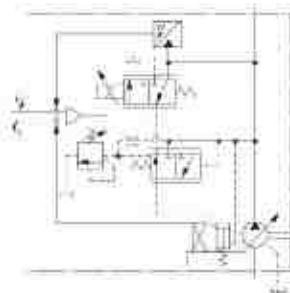

A16/A22/A37/A56

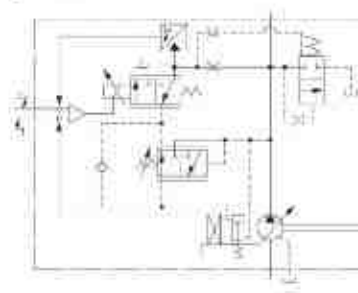

A70/A90/A145

Model Number Designation

A70	-F	R	04E	16	M	A	-60	-60	*
Series Number	Mounting	Direction of Rotation	Control Type	Control Pressure at Input Signal is 5 V	Unit of Control Pressure	Type of Outboard Pump	Compensation Number	Design Number	Design Std.
A16 (15.8 cm ³ /rev)	F: Flange Mtg.	Viewed from Shaft End	04E: Proportional Pressure & Flow Control Type	Use the same measure of the control pressure as shown on the right. 6.9 MPa specify within the range of maximum operating pressure.	M: MPa P: PSI	None ^{★1}	06	42	Refer to ★4
A22 (22.2 cm ³ /rev)							11	42	
A37 (36.9 cm ³ /rev)							01	42	
A56 (56.2 cm ³ /rev)							02	42	
A70 (70.0 cm ³ /rev)	L: Foot Mtg.	R: Clockwise (Normal)				A: ^{★2} B: ^{★2}	60	60	
A90 (91.0 cm ³ /rev)							60	60	
A145 (145.0 cm ³ /rev)							60	60	

★ 1. Available to supply pump with anti-clockwise rotation. Consult Yuken for details.

★ 2. These pumps, except A16 and A22 types, can be connected to outboard pumps.

- A37/A56 type (outboard pump connection symbol: **None**): spigot diameter: 82.55 mm (3.250 in.) (A16, A22, and PV2R1)

- A70/A90/A145 type (outboard pump connection symbol: **"A"**): spigot diameter: 82.55 mm (3.250 in.) (A16, A22, and PV2R1)

- A70/A90/A145 type (outboard pump connection symbol: **"B"**): spigot diameter: 101.6 mm (4.000 in.) (A37 and PV2R2)

★ 3. Amplifier Compensation Number may differ according to the main machine conditions. Consult Yuken for detail.

★ 4. Design Standard: **None** Japanese Standard "JIS"

80 European Design Standard

• Consult Yuken when "N. American Design Standard" is required.

Specifications

Descriptions		Model Numbers	A16	A22	A37	A56	A70	A90	A145	
Geometric Displacement		cm ³ /rev (cu. in./rev)	15.8 (.964)	22.2 (1.355)	36.9 (2.25)	56.2 (3.43)	70.0 (4.27)	91.0 (5.55)	145.0 (8.85)	
Operating Pressure MPa (PSI)	Rated ^{*1}		16 (2320)	16 (2320)	16 (2320)	16 (2320)	25 (3630)	25 (3630)	25 (3630)	
	Intermittent ^{*2}		21 (3050)	16 (2320)	21 (3050)	21 (3050)	28 (4060)	28 (4060)	28 (4060)	
Shaft Speed Range		r/min	600 - 1800							
Flow Control	Max. Flow ^{*3}	L/min (U.S. GPM)	28.4 (7.5)	40.0 (10.6)	66.4 (17.5)	101.0 (26.7)	126.0 (33.3)	163.0 (43.1)	261.0 (69.0)	
	Min. Pres. Required for Flow Adj.	MPa (PSI)	2.0 (290) ^{*4}							
	Hysteresis		1 % or less							
	Repeatability		1 % or less							
	Input Signal		Max. Flow / 5 V DC							
Pressure Control	Min. Adjustment Pressure	MPa (PSI)	0.7 (100)							
	Hysteresis		1 % or less							
	Repeatability		1 % or less							
	Input Signal		Specified Control Pressure / 5 V DC							
Coil Resistance		[@ 20°C (68°F)]	10							
Input Impedance			Flow Control : 10 kΩ Pressure Control : 10 kΩ							
Supply Electric Power			24 V DC (21 - 28 V Included Ripple)							
Power Input (Max.)		W	30							
Output Signal	Flow		5 V DC/Max. Flow							
	Pressure		5 V DC/Specified Control Pressure							
Alarm Signal Output (Open Collector)			Voltage : Max. 30 V DC Current : Max. 40 mA							
Ambient Temperature		°C (°F)	0 - 50 (32 - 122) (With Circulated Air)							
Approx. Mass kg (lbs.)	Flange Mtg.		20.5 (45.2)	20.5 (45.2)	32.0 (70.6)	39.0 (86.0)	64.0 (141)	76.5 (169)	96.4 (213)	
	Foot Mtg.		22.7 (50.1)	22.7 (50.1)	36.3 (80.0)	43.3 (95.5)	76.0 (168)	97.0 (214)	121.4 (268)	

- ★ 1. Whenever setting pressure, make sure the full cut-off pressure never exceeds the maximum intermittent pressure.
- ★ 2. When operating the pump exceeding the rated pressure, operating conditions are restricted. Refer to page 33 for the details.
- ★ 3. Maximum flow differs to shaft speed.
The value listed above indicates shaft speed of 1800 r/min.
For other shaft speed calculate by the ratio of shaft speed.
- ★ 4. To secure the required minimum pressure, special sequence valves are available, to be directly installed at the discharge port of the pump. Consult Yuken for details.

Pipe Flange Kits

For Pipe flange, refer to form of pressure compensator type on page 34.

Instructions

Input Signal

The pump is on unload condition when the pump is operated without input signal voltage.

Electric Source

Always turn off electric source whenever the connector for swash plate tilt angle sensor is removed.

Compensation of Pump Maximum Regulated Flow at Frequency

If the same maximum flow is required at 50 Hz or 60 Hz, connect short plug in the amplifier to 60 Hz at the place where supplied frequency is 60 Hz. At this condition, maximum flow comes to the same value at 50 Hz.

If short plug is used at 60 Hz without making the change, maximum flow increased in proportion to frequency.

Painting on Amp. Box and Solenoid

To maintain suitable radiation effect, the amp. Box and the solenoid of the control valve should not be painted.

■ Outboard Pumps

A37 to A145 type pumps, except A16 and A22, can be used as double pumps, by connecting an outboard pump on the cover side. See the table below for details.

● Connectable Outboard Pump

Outboard Pump Connection Symbol		Spigot Diameter for Connecting an Outboard Pump mm (in.)	Connectable Pump*
A37/A56	None	82.55 (2.500)	A16, A22, PV2R1
	"A"		
A70/A90/A145	"B"	101.6 (4.000)	A37, PV2R2

* Connectable pumps shafts are involute-serrated design, not the standard parallel key slot design. For details, including pump dimensions and model numbers, consult Yuken.

● Coupling

Please use assembly part number when ordering coupling assemblies for shaft connections to outboard pumps.

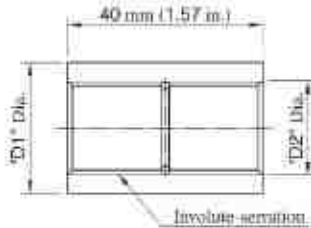

Outboard Pump Connection Symbol	Part Number of Coupling Ass'y	Dimensions mm (in.)		Serration Size (Nominal Dia. × No. of Teeth × Module)
		"D1"	"D2"	
A37/A56	None	27 (1.06)	19.5 (0.77)	18.75 × 24 × 0.75
	"A"	098-PK412588-6		
A70/A90/A145	"B"	36 (1.42)	26 (1.02)	25 × 24 × 1
	098-PK412623-1			

● Selecting an Outboard Pump Type

The maximum torque of outboard pumps is limited by shaft and coupling assembly strength. When determining the outboard pump type, the value of the displacement times the pressure for a particular pump should not exceed the value shown in the table below.

Pump Model No.	① Inboard Pump and Outboard Pump (q1 × P1) + (q2 × P2)	② Outboard Pump q2 × P2	
		Outboard pump connection symbol "None"/"A"	"B"
A37	900(7963) and less	519(4592) and less	935(8272) and less
A56	1742(15413) and less		
A70	2408(21305) and less		
A90	4348(38470) and less		
A145	4739(41930) and less		

- q1, q2 : Displacement cm³/rev (cu.in./rev)
- P1, P2 : Pressure MPa (PSI)
- For selection of the appropriate pump, both values, ① and ②, should be satisfied.

■ Attachment

● Amplifier

Pump Model Numbers	Amplifier Model Numbers	Control Pressure MPa (PSI)
A16-#R04E ★-06-42	SK1106-★-16-06-10	-14.7 (-2132)
	SK1106-★-16-06-1001	14.7 - 19.6 (2132 - 2842)
	SK1106-★-16-06-1002	19.6 - 21.0 (2842 - 3045)
A22-#R04E ★-11-42	SK1106-★-22-11-10	-14.7 (-2132)
	SK1106-★-22-11-1001	14.7 - 16.0 (2132 - 2320)
A37-#R04E ★-60-42	SK1106-★-37-60-10	-14.7 (-2132)
	SK1106-★-37-60-1001	14.7 - 19.6 (2132 - 2842)
	SK1106-★-37-60-1002	19.6 - 21.0 (2842 - 3045)
A56-#R04E ★-60-42	SK1106-★-56-60-10	-14.7 (-2132)
	SK1106-★-56-60-1001	14.7 - 19.6 (2132 - 2842)
	SK1106-★-56-60-1002	19.6 - 21.0 (2842 - 3045)
A70-#R04E ★*-60-60	SK1106-★-70-60-10	-14.7 (-2132)
	SK1106-★-70-60-1001	14.7 - 19.6 (2132 - 2842)
	SK1106-★-70-60-1002	19.6 - 22.6 (2842 - 3277)
A90-#R04E ★*-60-60	SK1106-★-70-60-1003	22.6 - (3277 -)
	SK1106-★-91-60-10	-14.7 (-2132)
	SK1106-★-91-60-1001	14.7 - 19.6 (2132 - 2842)
A145-#R04E ★*-60-60	SK1106-★-91-60-1002	19.6 - 22.6 (2842 - 3277)
	SK1106-★-91-60-1003	22.6 - (3277 -)
	SK1106-★-145-60-10	-14.7 (-2132)
A145-#R04E ★*-60-60	SK1106-★-145-60-1001	14.7 - 19.6 (2132 - 2842)
	SK1106-★-145-60-1002	19.6 - 22.6 (2842 - 3277)
	SK1106-★-145-60-1003	22.6 - (3277 -)

Note 1. The symbol "★", shown with pump and amplifier model numbers, is the control pressure at input signal of 5 V.
 2. Cable for pump-amplifier connection is not included. See Page 85 for details on ordering cables.



■ Output Flow vs. Input Signal

● A16

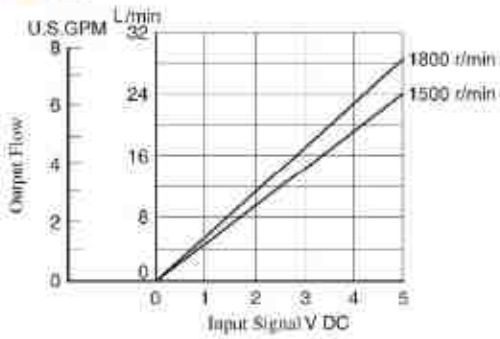

● A56

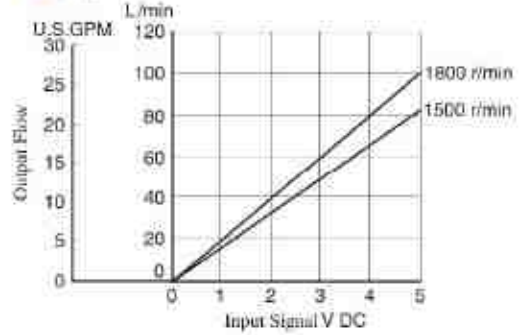

● A22

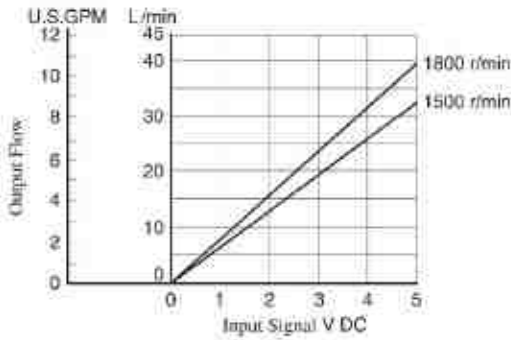

● A70

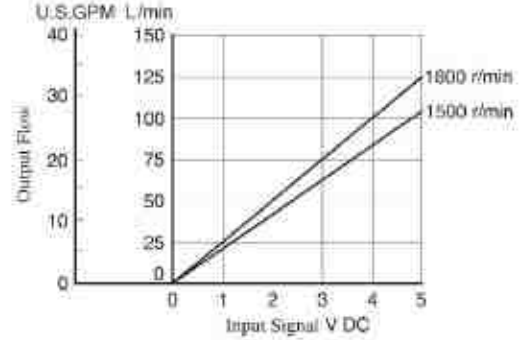

● A37

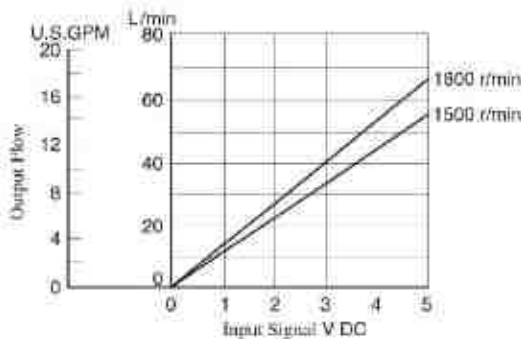

● A90

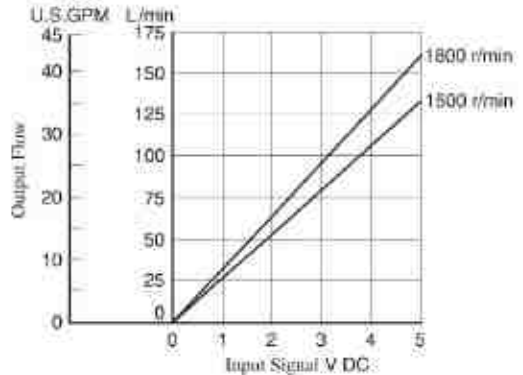

Note: Pump characteristics at 1800 r/min is the same as those at 1500 r/min where frequency is compensated. (Refer to page 75.)

● A145

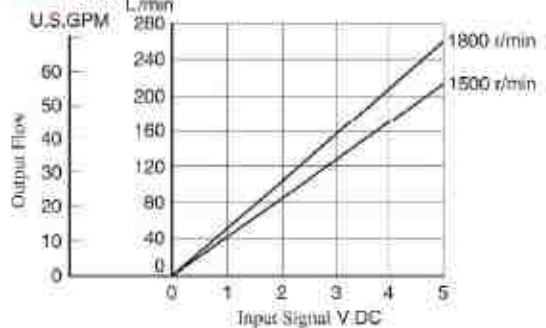

■ Full Cut-off Pres. vs. Input Signal

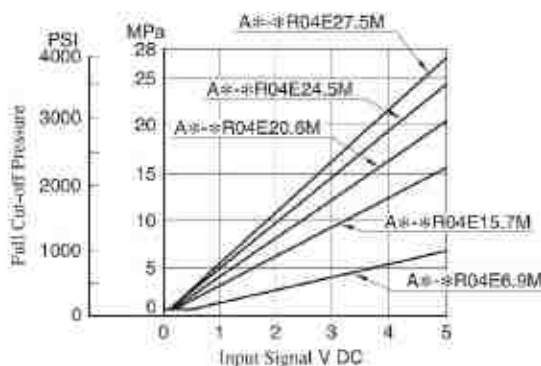

Refer to page 37 to 43 for performance characteristics of pressure compensator type excluding characteristics appeared on this catalogue.

Flange Mfg. : A16-FR04E*-06-42/4280
 A22-FR04E*-11-42/4280

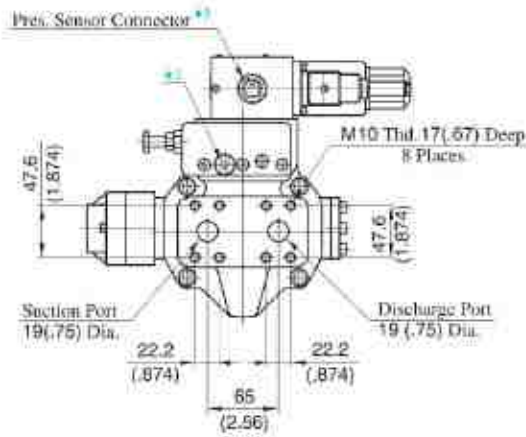
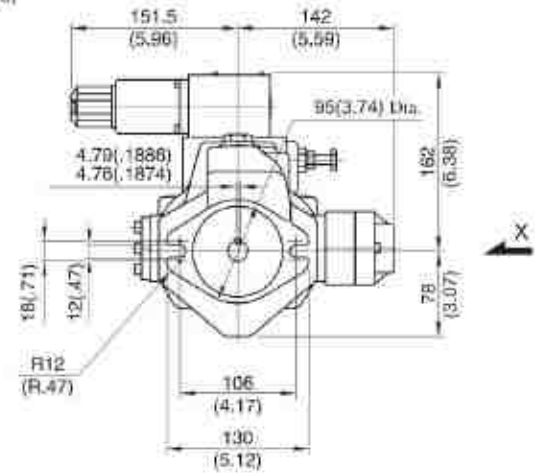
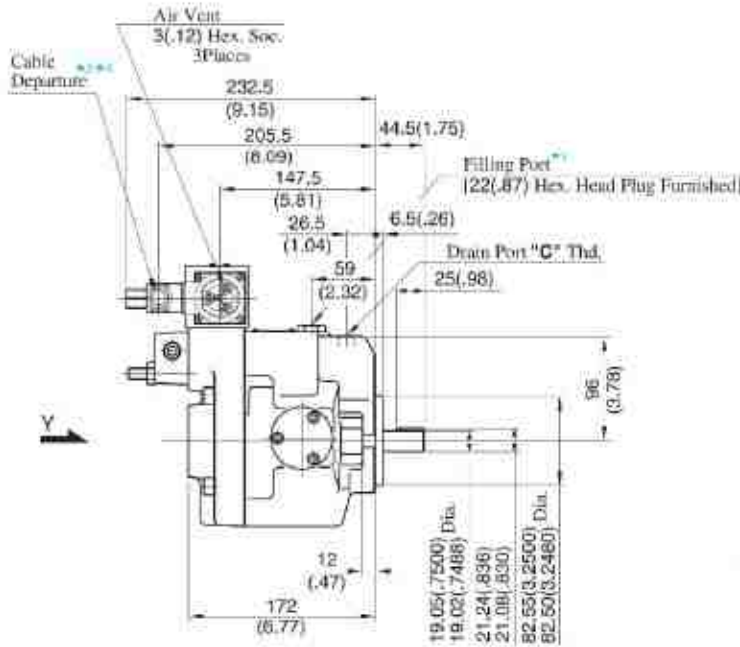

View Arrow Y

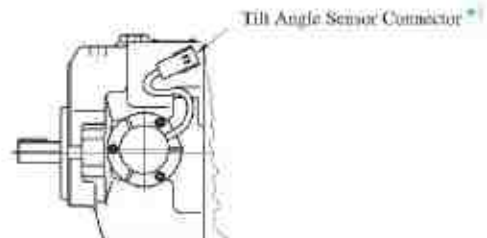

View Arrow X

- ★ 1. Install the pump so that the "Filling Port" is at the top.
- ★ 2. Do not touch the screw because it is adjusted at the time of shipment.
- ★ 3. For cable connection with amplifiers, see [page 85](#).
- ★ 4. Cable Applicable:
 Outside Dia. 8-10mm(.31-.39 IN.)
 Conductor Area Not Exceeding 1.5mm²(.023 Sq. IN.)

Model Numbers	"C" Thd.
A16/A22-FR04E*-06-42	Rc 3/8
A16/A22-FR04E*-11-4280	3/8 BSP.F

DIMENSIONS IN
MILLIMETRES (INCHES)

● **Foot Mounting Type**

Mounting bracket is common to that of pressure compensator model.
 Refer to [page 45](#) for the dimensions of mounting bracket.

Flange Mfg. : A37-FR04E*-01-42/4280

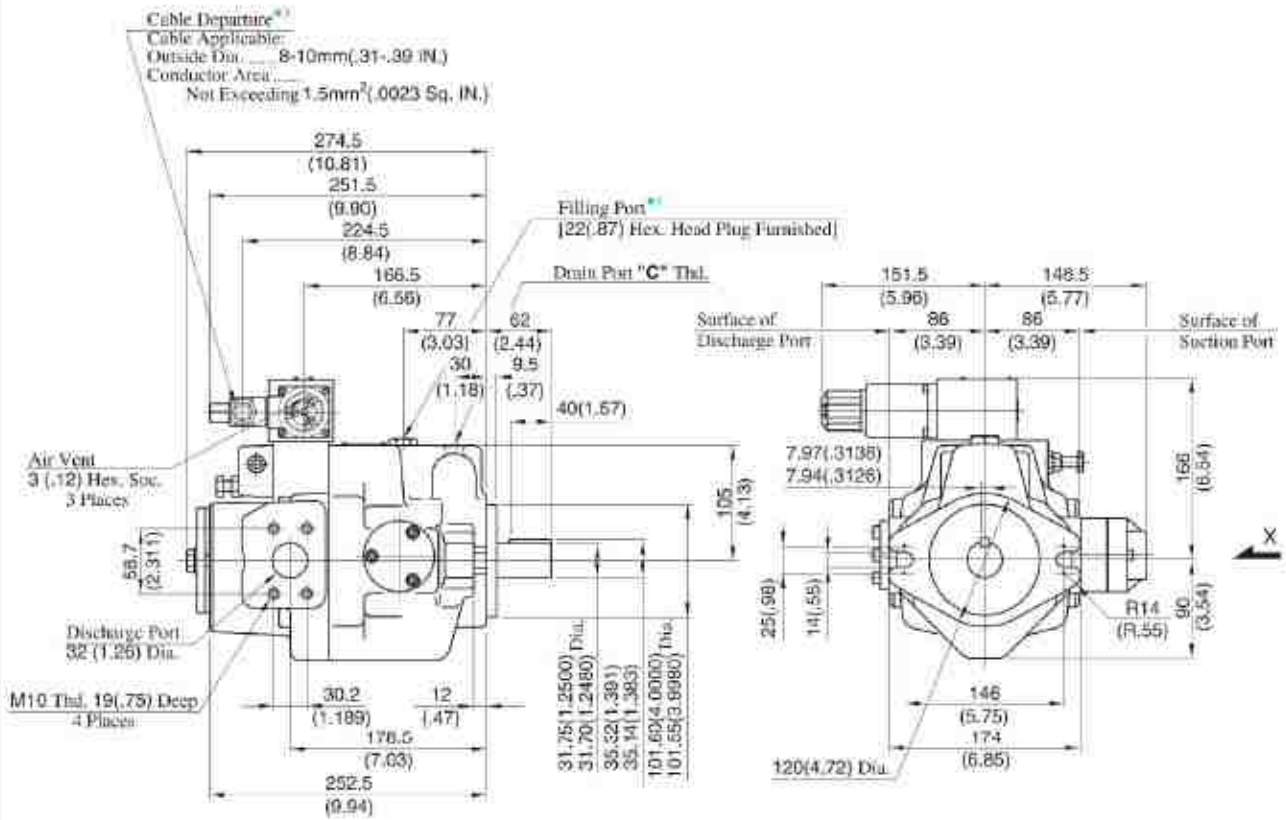

- ★ 1. Install the pump so that the "Filling Port" is at the top.
- ★ 2. Do not touch the screw because it is adjusted at the time of shipment.
- ★ 3. For cable connection with amplifiers; see page 85.

Model Numbers	"C" Thd.
A37-FR04E*-01-42	Rc 1/2
A37-FR04E*-01-4280	1/2 BSP.F

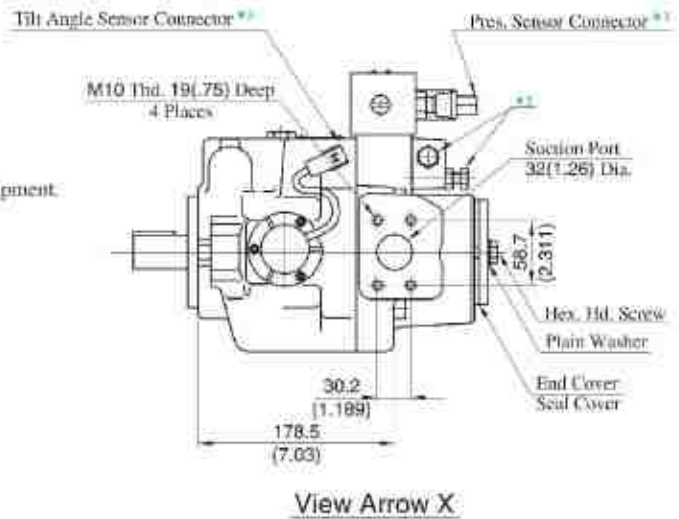

DIMENSIONS IN MILLIMETRES (INCHES)

● **Foot Mounting Type**

Mounting bracket is common to that of pressure compensator model.
 Refer to page 46 for the dimensions of mounting bracket.

Flange Mtg. : A56-FR04E*-02-42/4280

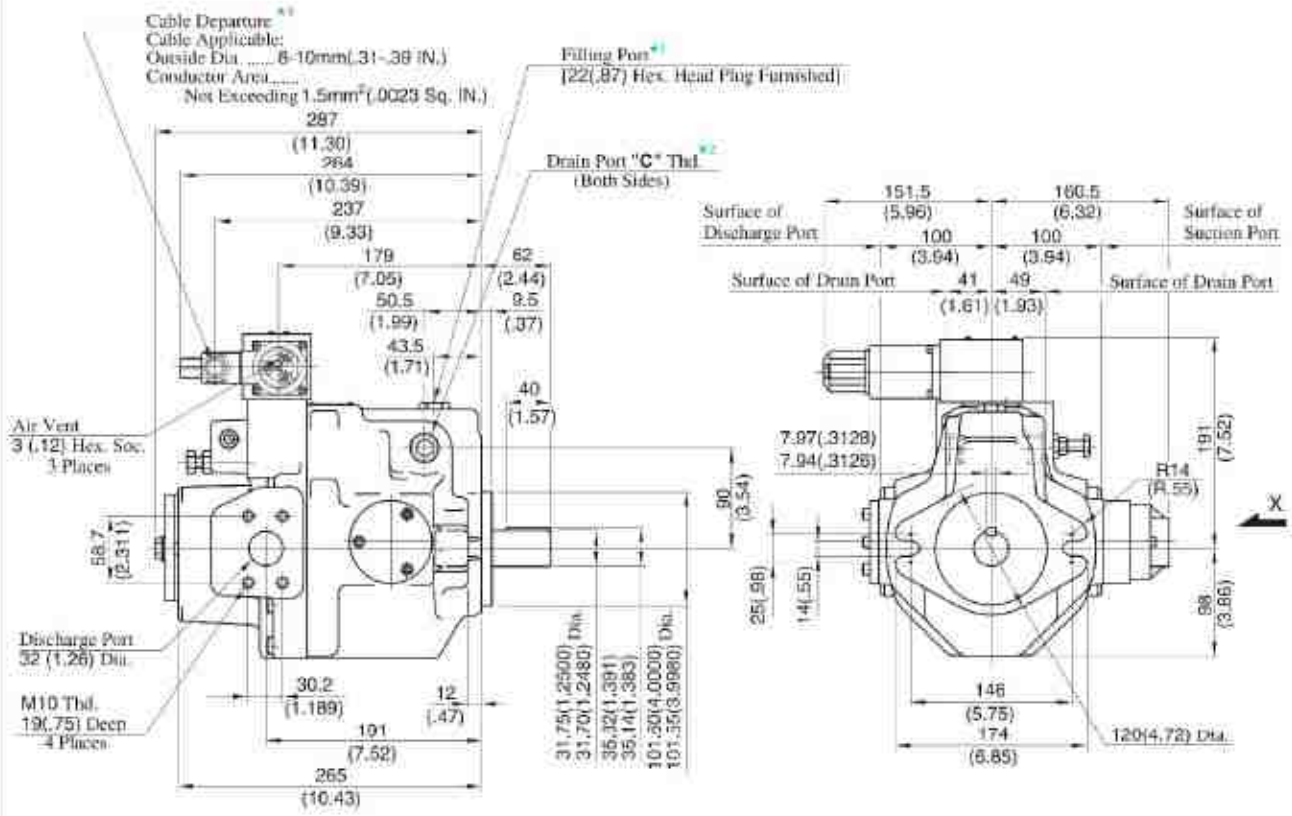

- ★ 1 Install the pump so that the "Filling Port" is at the top.
- ★ 2 Use either port of two drain ports at your option. Keep the remaining port plugged.
- ★ 3 Do not touch the screw, because it is adjusted at the time of shipment.
- ★ 4 For cable connection with amplifiers, see [page 85](#).

Model Numbers	"C" Thd.
A56-FR04E*-02-42	R _e 1/4
A56-FR04E*-02-4280	3/4 BSP.F

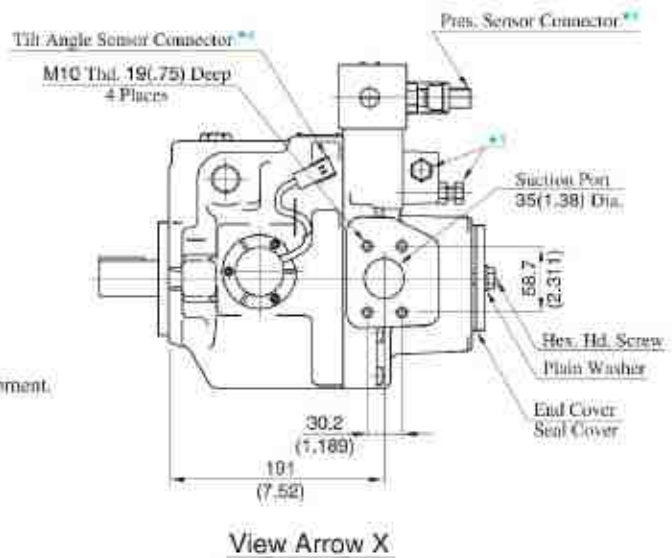

View Arrow X

DIMENSIONS IN MILLIMETRES (INCHES)

● **Foot Mounting Type**

Mounting bracket is common to that of pressure compensator model.
Refer to [page 47](#) for the dimensions of mounting bracket.

Flange Mtg. : A70-FR04E**-60-60/6080

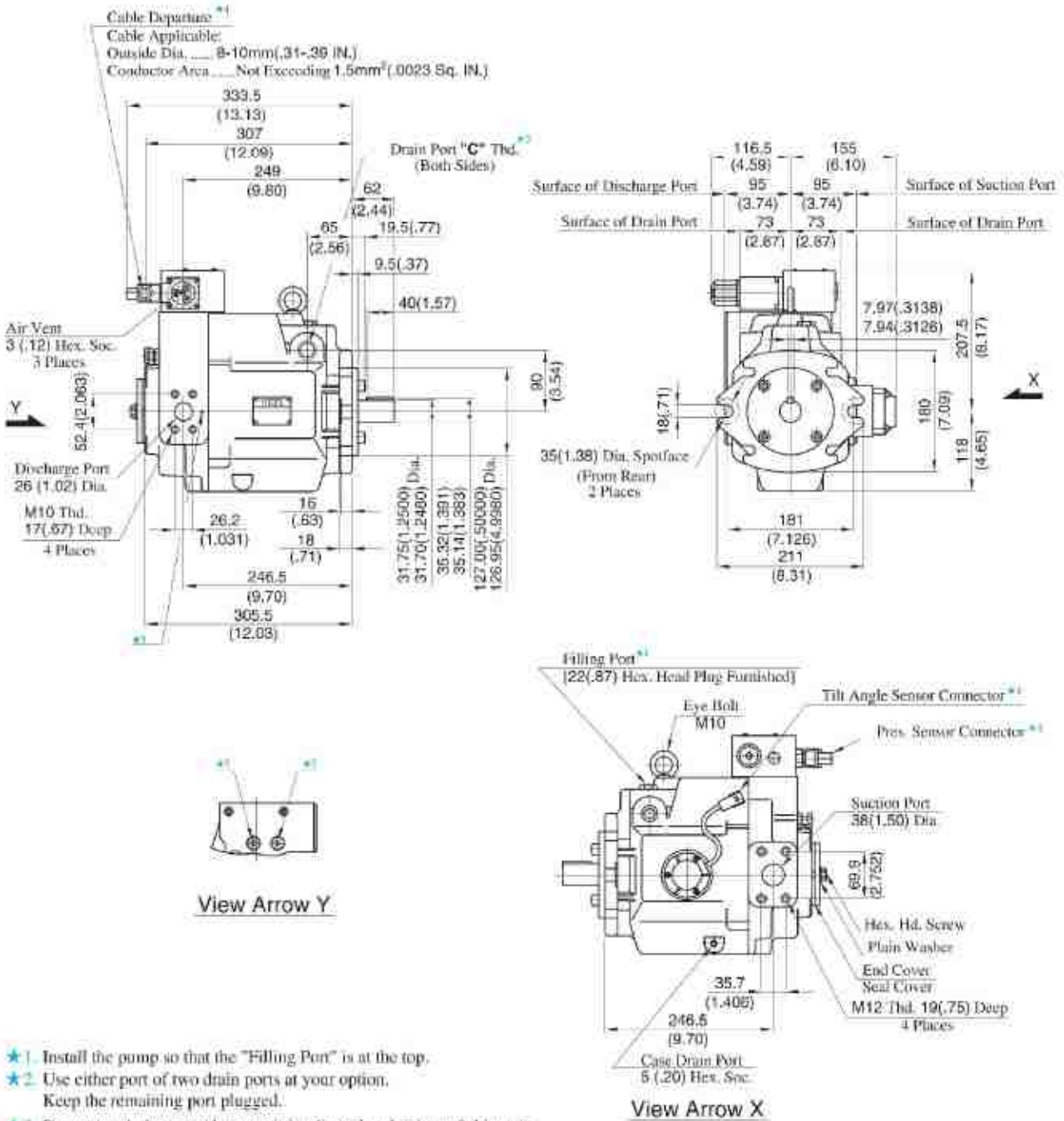

- ★1. Install the pump so that the "Filling Port" is at the top.
- ★2. Use either port of two drain ports at your option. Keep the remaining port plugged.
- ★3. Do not touch the screws because it is adjusted at the time of shipment.
- ★4. For cable connection with amplifiers, see page 85.
- ★5. If you do not use the special sequence valve, plug the port (FP-SC-1/32).

Model Numbers	"C" Thd.
A70-FR04E**-60-60	Rc 3/4
A70-FR04E**-60-6080	3/4 BSP.F

DIMENSIONS IN MILLIMETRES (INCHES)

● **Foot Mounting Type**

Mounting bracket is common to that of pressure compensator model.
Refer to page 48 for the dimensions of mounting bracket.

Flange Mtg. : A90-FR04E**-60-60/6080

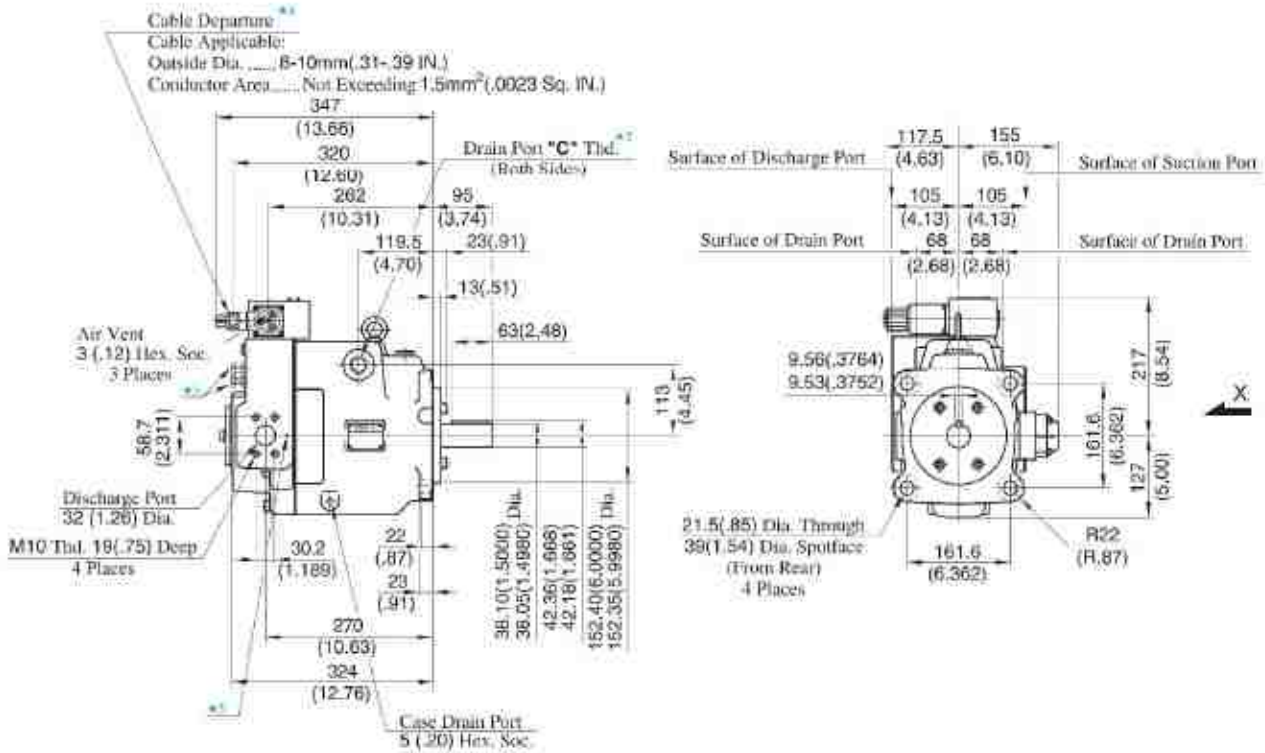

- ★ 1. Install the pump so that the "Filling Port" is at the top.
- ★ 2. Use either port of two drain ports at your option.
Keep the remaining ports plugged.
- ★ 3. Do not touch the screw because it is adjusted at the time of shipment.
- ★ 4. For cable connection with amplifiers, see page 85.
- ★ 5. If you do not use the special sequence valve, plug the port (FP-SC-1/32).

Model Numbers	"C" Thd.
A90-FR04E**-60-60	Rc 3/4
A90-FR04E**-60-6080	3/4 BSP.F

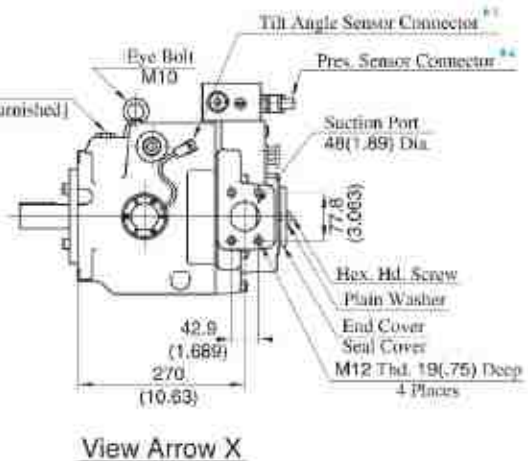

DIMENSIONS IN MILLIMETRES (INCHES)

● **Foot Mounting Type**

Mounting bracket is common to that of pressure compensator model.
Refer to page 49 for the dimensions of mounting bracket.

Flange Mtg. : A145-FR04E※-60-60/6080

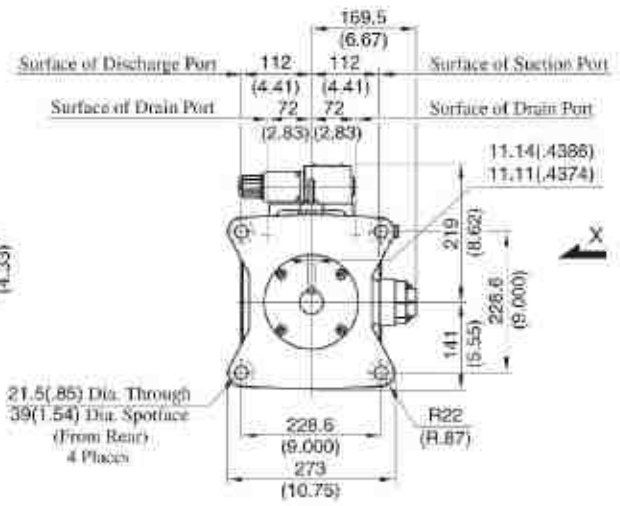
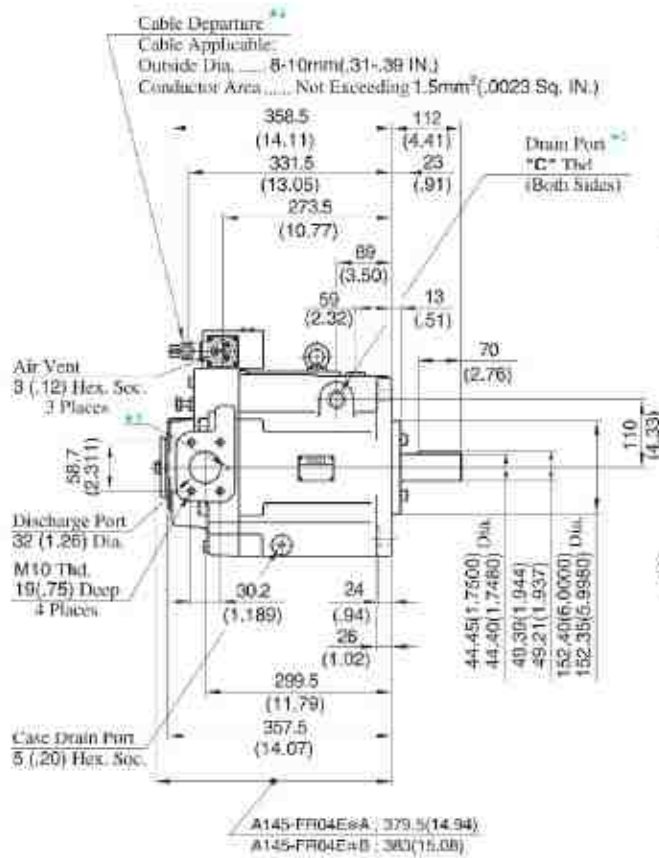

- ★ 1. Install the pump so that the "Filling Port" is at the top.
- ★ 2. Use either port of two drain ports at your option. Keep the remaining port plugged.
- ★ 3. Do not touch the screw because it is adjusted at the time of shipment.
- ★ 4. For cable connection with amplifiers, see page 85.
- ★ 5. If you do not use the special sequence valve, plug the port (FP-SC-1/32).

Model Numbers	*C" Thd.
A145-FR04E※-60-60	Rc 3/4
A145-FR04E※-60-6080	3/4 BSP.F

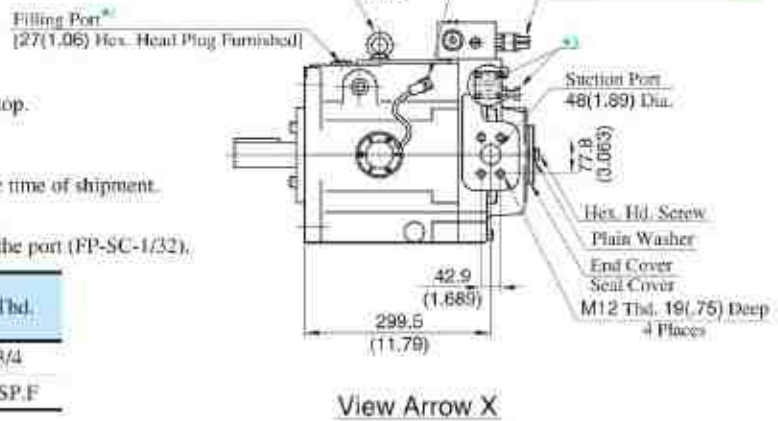

DIMENSIONS IN MILLIMETRES (INCHES)

● Foot Mounting Type

Mounting bracket is common to that of pressure compensator model. Refer to page 50 for the dimensions of mounting bracket.

Amplifiers for Electro-Hydraulic Proportional Pressure & Flow Control Type Pumps (SK1106-★-★-★-10★★)

Specifications

Description	Model No.	SK1106-★-★-★-10★★
Applicable Coil Resistance		10 Ω [at 20 °C (68 °F)]
Input Impedance		10 kΩ (PIN, QIN)
Power Supply		24 V DC (21 - 28 V Included Ripple)
Power Input (Max.)		30 W
Input Signal		Max. Flow/5V (QIN), Specified Pres./5V (PIN)
Output Signal for Sensor Monitor		5V/Max. Flow (SMQ), 5V/Specified Pres. (SMP)
Ambient Temperature		0 - 50 °C (32 - 122 °F)
Approx. Mass		450 g (1.0 lbs.)

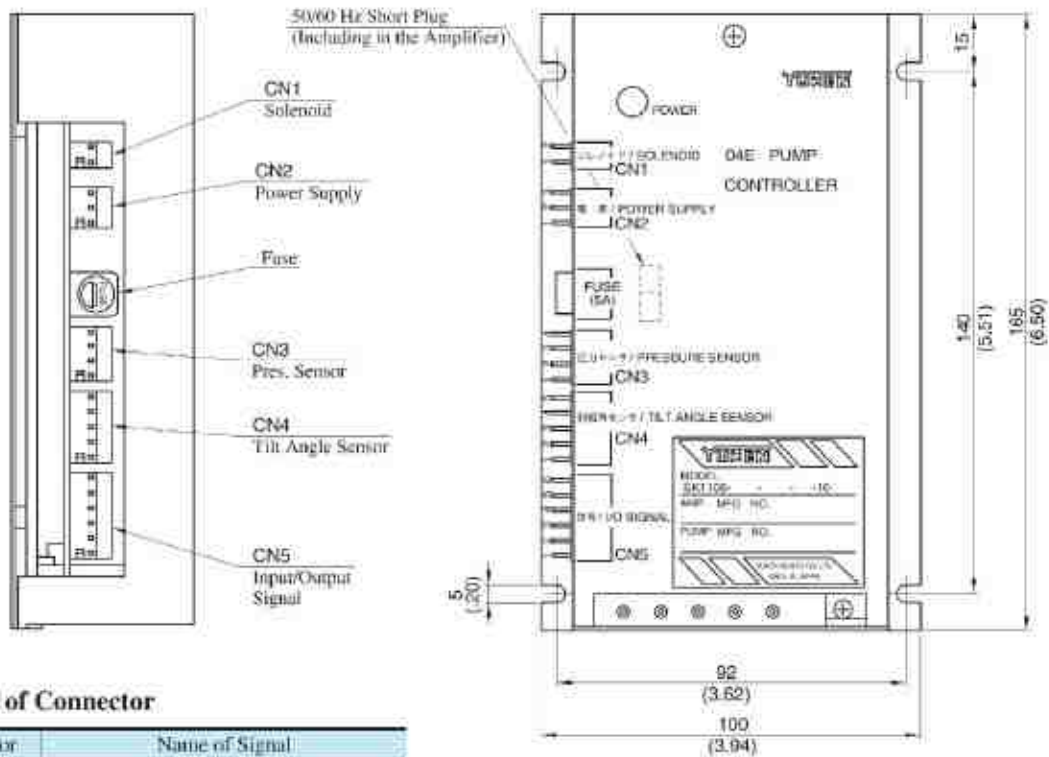

Detail of Connector

Connector	Name of Signal	
CN1 Solenoid	1	Output to pilot valve solenoid
	2	
CN2 Power Supply	1	0 [V] (0V ₋)
	2	+24 [V] (24V)
	3	0 [V]
CN3 Pres. Sensor	1	+5 [V] Power Supply for Sensor
	2	0 [V]
	3	Input Signal - Sensor
	4	0 [V]
CN4 Tilt Angle Sensor	1	+8 [V] Power Supply for Sensor
	2	0 [V]
	3	Input Signal - Sensor
	4	0 [V]
	5	—
CN5 Input/Output Signal	1	Input Signal - Flow (Qin)
	2	Input Signal - Common (COM)
	3	Input Signal - Pres. (Pin)
	4	Output Signal - Sensor Monitor P (SMP)
	5	Output Signal - Sensor Monitor Q (SMQ)
	6	0 [V]

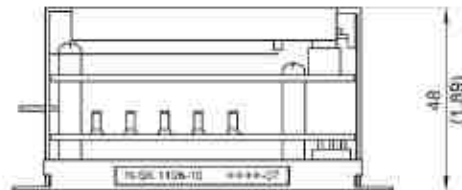

DIMENSIONS IN MILLIMETRES (INCHES)



Cable Connection Between Pump and Amplifier

The cable connections between the proportional pilot valve and the sensor of the pump and the attached amplifier (SK1106) are shown below.

The cable assemblies are not included in the pump assembly. Purchase separately with model number described in the below table if required.

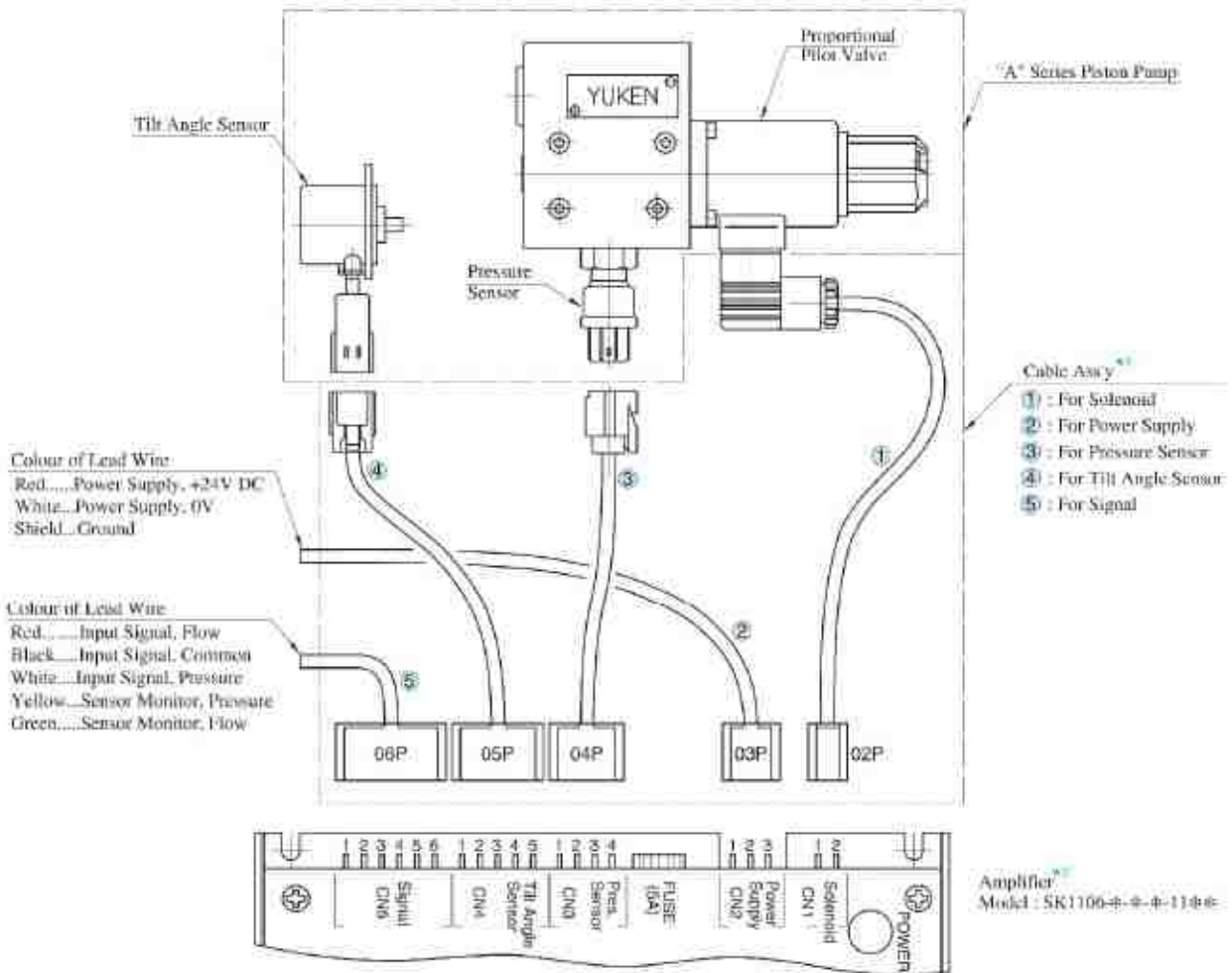

* 1. Cable assemblies are available. When ordering, specify the cable ass'y model numbers from the table below.

Name of Cable Ass'y	Cable Ass'y Model Numbers		
	Approx. Length of Cable mm(ft.)		
	2000 (6.6)	5000 (16.4)	10000 (32.8)
① For Solenoid	SK1112-S-2-10	SK1112-S-5-10	SK1112-S-10-10
② For Power Supply	SK1112-V-2-10	SK1112-V-5-10	SK1112-V-10-10
③ For Pressure Sensor	SK1112-P-2-10	SK1112-P-5-10	SK1112-P-10-10
④ For Tilt Angle Sensor	SK1112-Q-2-10	SK1112-Q-5-10	SK1112-Q-10-10
⑤ For Signal	SK1112-C-2-10	SK1112-C-5-10	SK1112-C-10-10

* 2. For the details of amplifier, see the [previous page](#).

"A" Series Variable Displacement Piston Pumps – Single Pump, "OBE" Type Electro-Hydraulic Proportional Pressure & Flow Control Type

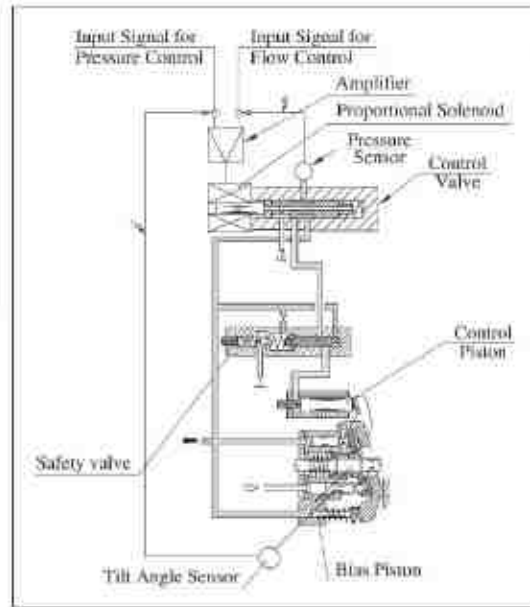

Performance Characteristics

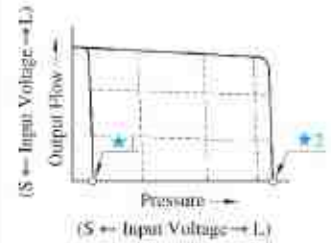

- ★1. Unloading pressure when input signal is 0 V.
- ★2. Safety valve setting pressure.

Graphic Symbols

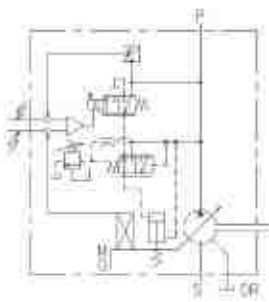

A16/A22/A37/A56

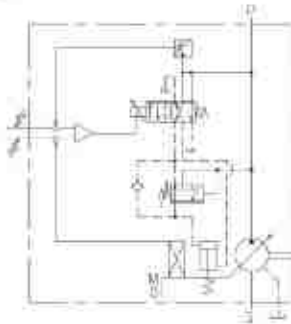

A70/A90/A145

Example of Specified Control Pressure

Control Pressure Symbol (EX.)	Control Pressure at Input Signal is 5 V			
	kgf/cm ²	MPa	PSI	
70	70	6.9	1000	
105	105	10.3	1500	
140	140	13.7	2000	
175	175	17.2	2500	
210	210	20.6	3000	
—	7M	71.4	7	1015
—	16M	163.2	16	2320
—	21M	214.2	21	3045

Model Number Designation

A16	-F	R	04EH	70	R	S	-06	-42	*	
Series Number	Mounting	Direction of Rotation	Control Type	Control Pressure at Input Signal is 5 V	Amplifier Direction	Port Position	Compensation Number	Design Number	Design Std.	
A16 (15.8 cm ³ /rev)	F: Flange Mtg.	<i>(Viewed from Shaft End)</i>	04EH: "OBE" Type Proportional Pressure & Flow Control Type	Specify Control Pressure between 6.9 MPa and Maximum Operating Pressure (Refer to above Table).	<i>(Viewed from Shaft End)</i>	R: Right L: Left	S: Side Port	06	42	Refer to ★3
A22 (22.2 cm ³ /rev)								11	42	
A37 (36.9 cm ³ /rev)								01	42	
A56 (56.2 cm ³ /rev)								02	42	
A70 (70.0 cm ³ /rev)								60	60	
A90 (91.0 cm ³ /rev)	L: Foot Mtg.	R: Clockwise (Normal)					60	60		
A145 (145.0 cm ³ /rev)							60	80		

- ★1. Available to supply pump with anti-clockwise rotation. Consult Yuken for details.
- ★2. Amplifier Compensation Number may differ according to the main machine conditions. Consult Yuken for detail.
- ★3. Design Standards: None.....Japanese Standard "JIS"
950.....N.American Design Standard



Specifications

Descriptions		Model Numbers	A16	A22	A37	A56	A70	A90	A145	
Geometric Displacement		cm ³ /rev (cu. in./rev)	15.8 (.964)	22.2 (1.355)	36.9 (2.25)	56.2 (3.43)	70.0 (4.27)	91.0 (5.55)	145.0 (8.85)	
Operating Pressure MPa (PSI)	Rated ^{*1}		16 (2320)	16 (2320)	16 (2320)	16 (2320)	25 (3625)	25 (3625)	25 (3625)	
	Intermittent ^{*2}		21 (3050)	16 (2320)	21 (3050)	21 (3050)	28 (4060)	28 (4060)	28 (4060)	
Shaft Speed Range		r/min	600 - 1800							
Flow Control	Max. Flow ^{*3}	L/min (U.S. GPM)	28.4 (7.5)	40.0 (10.6)	66.4 (17.5)	101.2 (26.7)	126.0 (33.3)	163.0 (43.1)	261.0 (69.0)	
	Min. Pres. Required for Flow Adj.	MPa (PSI)	2.0 (290)							
	Hysteresis		1 % or less							
	Repeatability		1 % or less							
	Input Signal		Max. Flow / 5 V DC							
Pressure Control	Min. Adjustment Pressure	MPa (PSI)	0.7 (100)							
	Hysteresis		1 % or less							
	Repeatability		1 % or less							
	Input Signal		Specified Control Pressure / 5 V DC							
Coil Resistance		Ω [at 20°C (68°F)]	10							
Input Impedance			Flow Control : 10kΩ Pres. Control : 10kΩ							
Supply Electric Power			24 V DC (21 - 28 V Included Ripple)							
Power Input (Max.)		W	30							
Output Signal	Flow		5 V DC / Max. Flow							
	Pressure		5 V DC / Specified Control Pressure							
Alarm Signal Output (Open Collector)			Voltage : Max. 30 V DC Current : Max. 40 mA							
Ambient Temperature		°C (°F)	0 - 50 (32 - 122) (With Circulated Air)							
Mass	kg (lbs.)	Flange Mtg.	20.7 (45.6)	20.7 (45.6)	32.2 (71)	39.2 (86.4)	64 (141)	76.5 (169)	98 (216)	
		Foot Mtg.	22.9 (50.5)	22.9 (50.5)	36.5 (80.5)	43.5 (95.9)	76 (168)	97 (214)	123 (271)	

- *1. Whenever setting pressure, make sure the full cut-off pressure never exceeds the maximum intermittent pressure.
- *2. When operating the pump exceeding the rated pressure, operating conditions are restricted. Refer to page 33 for the details.
- *3. Maximum flow differs to shaft speed.
The value listed above indicates shaft speed of 1800 r/min.
For other shaft speed calculate by the ratio of shaft speed.

Pipe Flange Kits

For Pipe flange, refer to form of pressure compensator type on page 34.

Instructions

Input Signal

The pump is on unload condition when the pump is operated without input signal voltage.

Electric Source

Always turn off electric source whenever the connector for swash plate tilt angle sensor is removed.

Compensation of Pump Maximum Regulated Flow at Frequency

If the same maximum flow is required at 50 Hz or 60 Hz, connect short plug in the amplifier to 60 Hz at the place where supplied frequency is 60 Hz. At this condition, maximum flow comes to the same value at 50 Hz.

If short plug is used at 60 Hz without making the change, maximum flow increased in proportion to frequency.

Painting on Amp. Box and Solenoid

To maintain suitable radiation effect, the amp. box and the solenoid of the control valve should not be painted.

■ Output Flow vs. Input Signal

● A16

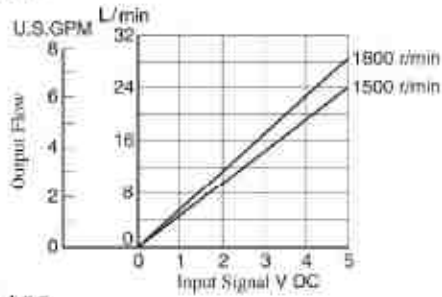

● A56

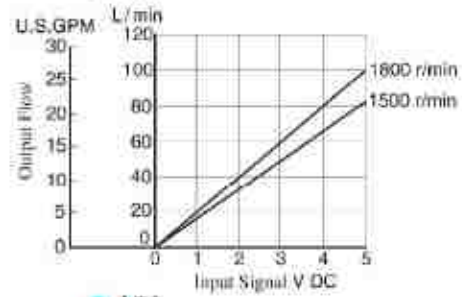

● A22

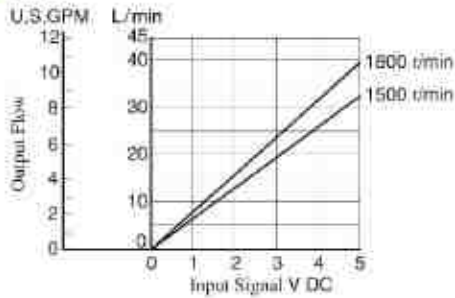

● A70

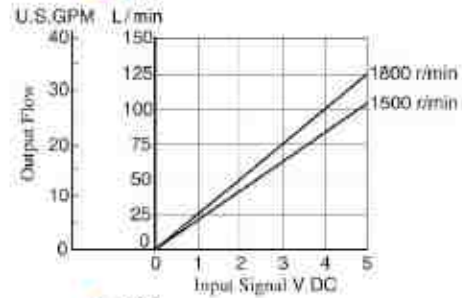

● A37

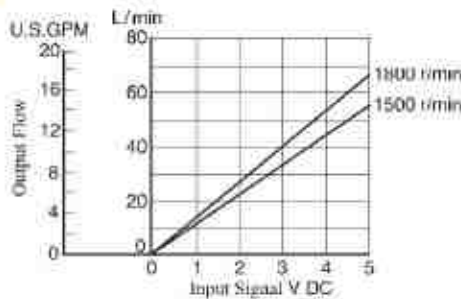

● A90

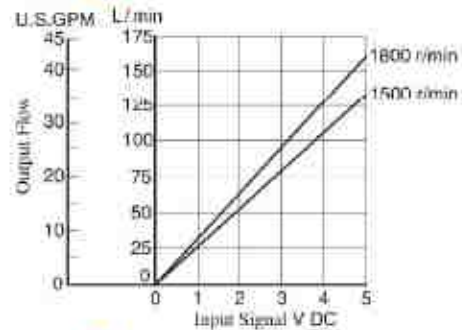

Note: Pump characteristics at 1800 r/min is the same as those at 1500 r/min where frequency is compensated. (Refer to page 87.)

● A145

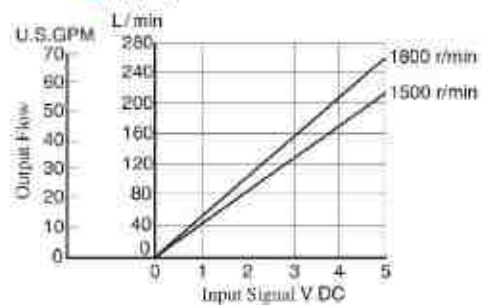

■ Full Cut-off Pres. vs. Input Signal

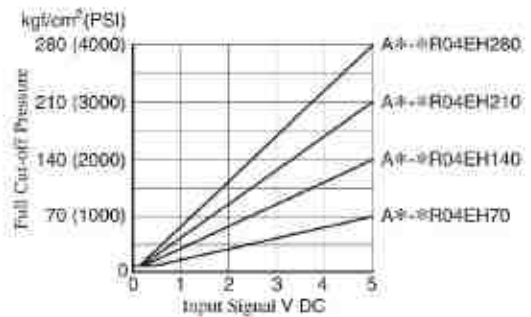
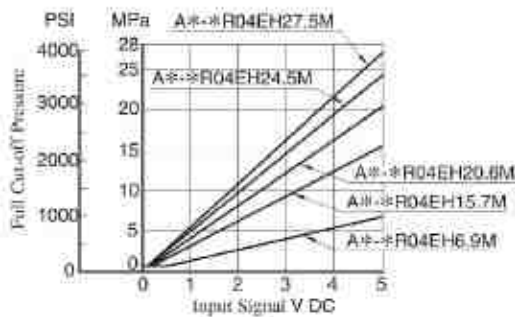

Refer to page 37 to 43 for performance characteristics of pressure compensator type excluding characteristics appeared on this catalogue.



Axial Port Type

Flange Mtg.: A16-FR04EH*-*-42/42950
A22-FR04EH*-*-42/42950

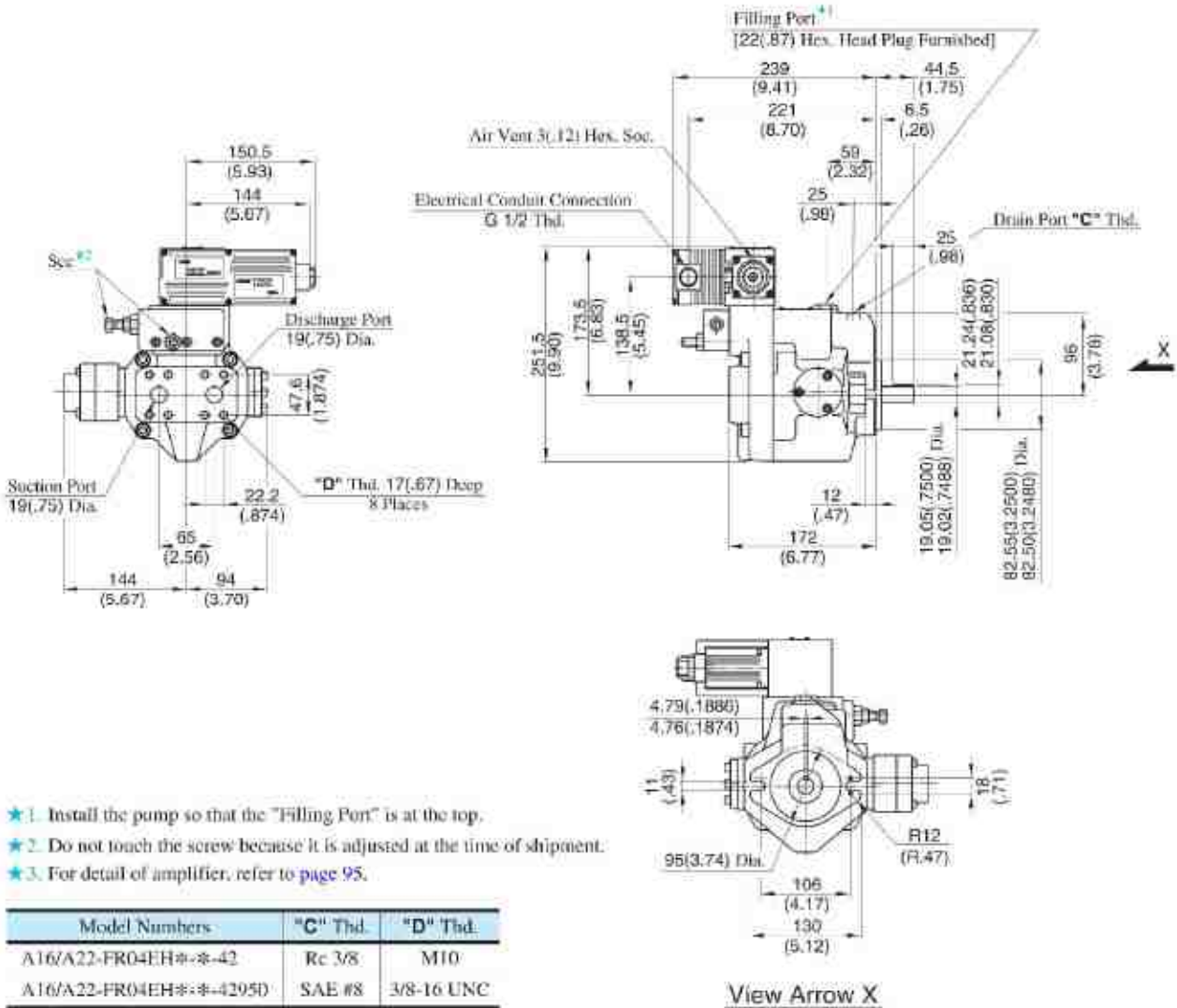

- ★ 1. Install the pump so that the "Filling Port" is at the top.
- ★ 2. Do not touch the screw because it is adjusted at the time of shipment.
- ★ 3. For detail of amplifier, refer to page 95.

Model Numbers	"C" Thd.	"D" Thd.
A16/A22-FR04EH*-*-42	Rc 3/8	M10
A16/A22-FR04EH*-*-42950	SAE #8	3/8-16 UNC

DIMENSIONS IN MILLIMETRES (INCHES)

● **Side Port Type**

Port mounting dimensions are the same as those of pressure compensator model. Refer to page 45 for port mounting dimensions.

● **Foot Mounting Type**

Mounting bracket is common to that of pressure compensator model. Refer to page 45 for the dimensions of mounting bracket.

Axial Port Type

Flange Mtg.: A37-FR04EH*-*-42/42950

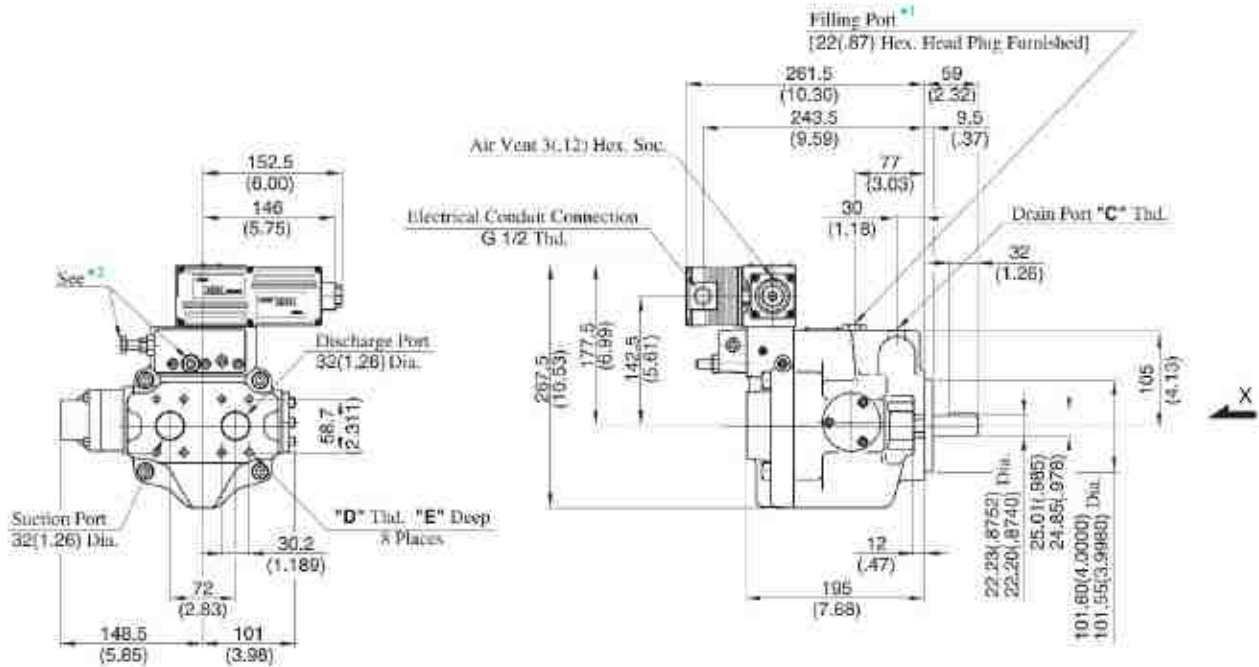

- ★ 1. Install the pump so that the "Filling Port" is at the top.
- ★ 2. Do not touch the screw because it is adjusted at the time of shipment.
- ★ 3. For detail of amplifier, refer to page 95.

Model Numbers	"C" Thd.	"D" Thd.	"E" mm (IN.)
A37-FR04EH*-*-42	Rc 1/2	M10	19 (.75)
A37-FR04EH*-*-42950	SAE #10	7/16-14 UNC	20 (.79)

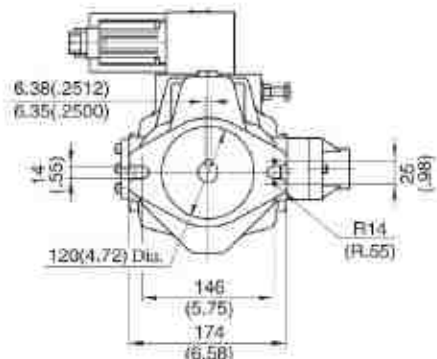

View Arrow X

DIMENSIONS IN MILLIMETRES (INCHES)

● **Side Port Type**

Port mounting dimensions are the same as those of pressure compensator model. Refer to page 46 for port mounting dimensions.

● **Foot Mounting Type**

Mounting bracket is common to that of pressure compensator model. Refer to page 46 for the dimensions of mounting bracket.



Axial Port Type

Flange Mtg.: A56-FR04EH*-*-42/4290

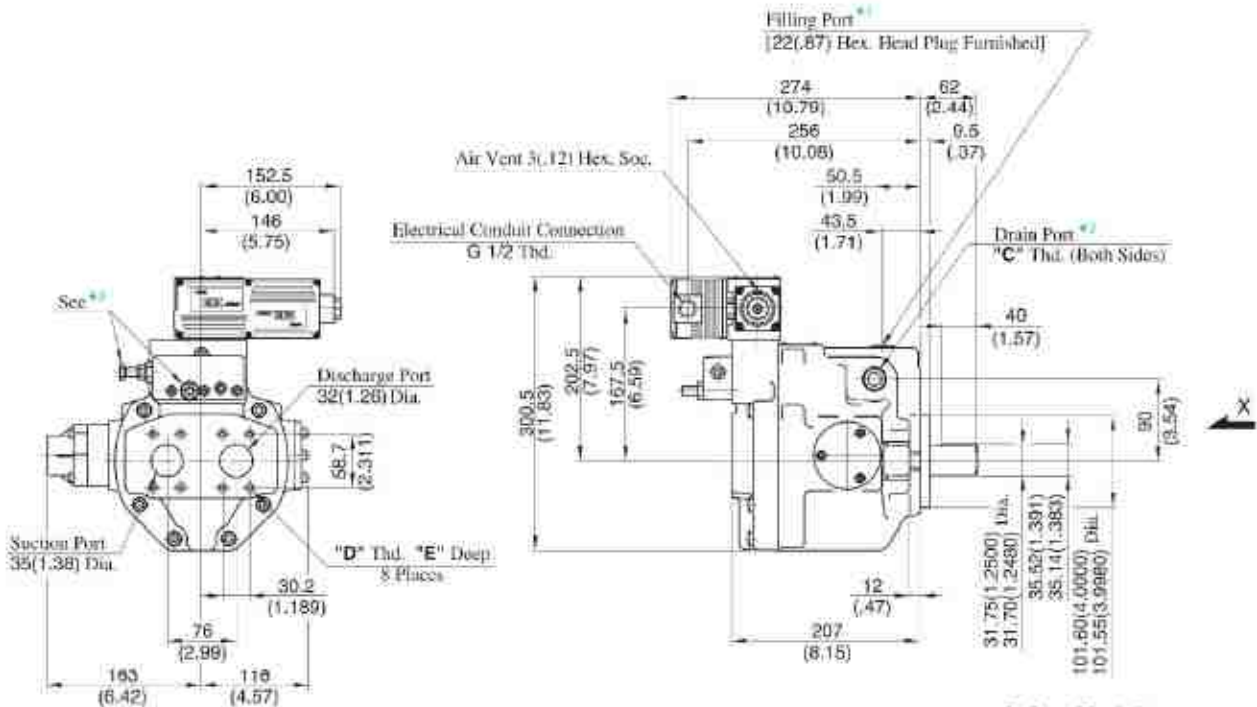

- ★ 1. Install the pump so that the "Filling Port" is at the top.
- ★ 2. Use either port of two drain ports at your option. Keep the remaining port plugged.
- ★ 3. Do not touch the screw because it is adjusted at the time of shipment.
- ★ 4. For detail of amplifier, refer to page 95.

Model Numbers	"C" Thd.	"D" Thd.	"E" mm (IN.)
A56-FR04EH*-*-42	Rc 3/4	M10	19 (.75)
A56-FR04EH*-*-4290	SAE #12	7/16-14 UNC	20 (.79)

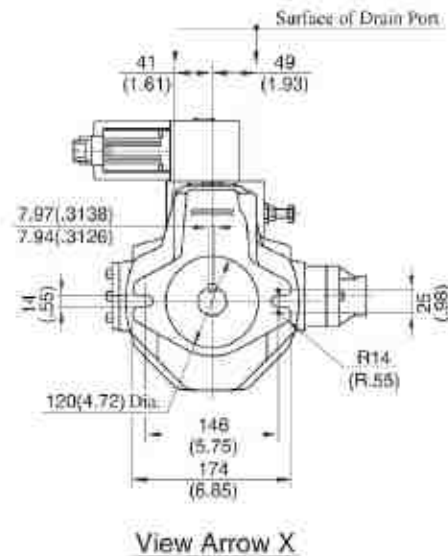

DIMENSIONS IN MILLIMETRES (INCHES)

Side Port Type

Port mounting dimensions are the same as those of pressure compensator model. Refer to page 47 for port mounting dimensions.

Foot Mounting Type

Mounting bracket is common to that of pressure compensator model. Refer to page 47 for the dimensions of mounting bracket.

Flange Mtg.

- Amplifier Direction "L" : A70-FR04EH*LS-*-60/60950

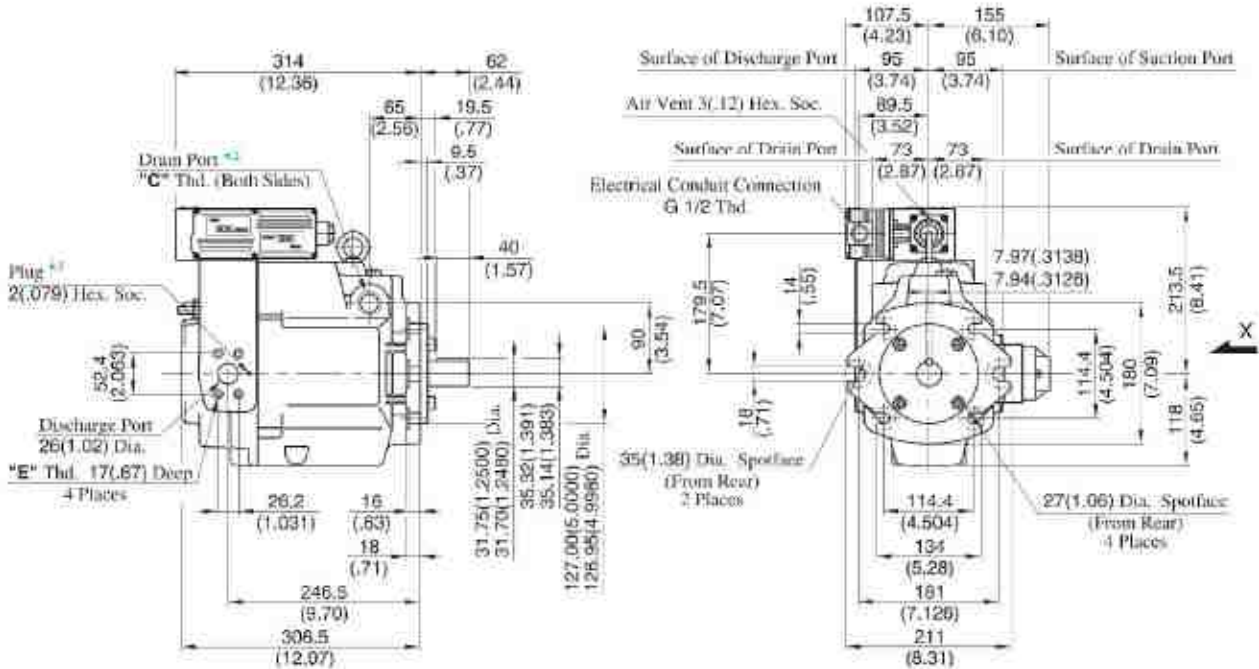

- Amplifier Direction "R" : A70-FR04EH*RS-*-60/60950

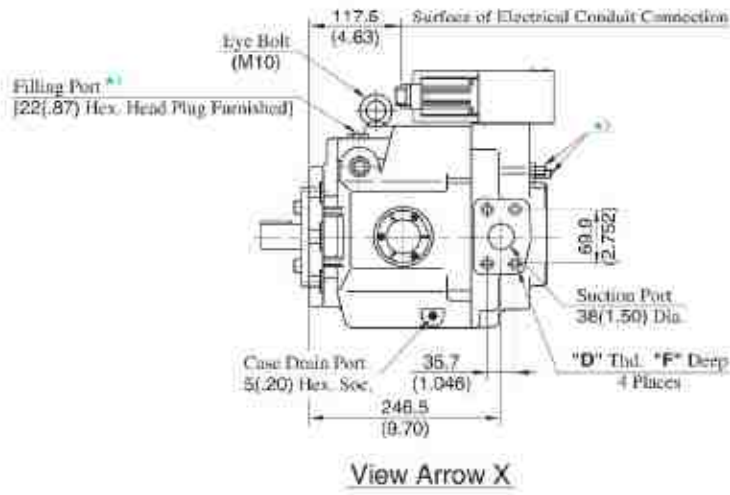
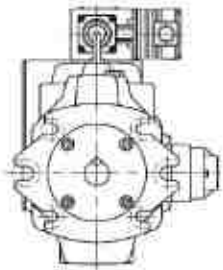

- ★ 1. Install the pump so that the "Filling Port" is at the top.
- ★ 2. Use either port of two drain ports at your option. Keep the remaining port plugged.
- ★ 3. Do not touch the screw because it is adjusted at the time of shipment.
- ★ 4. For detail of amplifier, refer to page 95.
- ★ 5. If you use the special sequence valve, remove the plug.

Model Numbers	"C" Thd.	"D" Thd.	"E" Thd.	Dimensions mm (IN.)
				F
A70-FR04EH*S-*-60	Rc 3/4	M12	M10	19 (.75)
A70-FR04EH*S-*-60950	SAE #12	1/2-13 UNC	3/8-16 UNC	21 (.83)

DIMENSIONS IN MILLIMETRES (INCHES)

● **Foot Mounting Type**

Mounting bracket is common to that of pressure compensator model. Refer to page 48 for the dimensions of mounting bracket.



Flange Mtg.

- Amplifier Direction "L" : A90-FR04EH*LS-*-60/60950

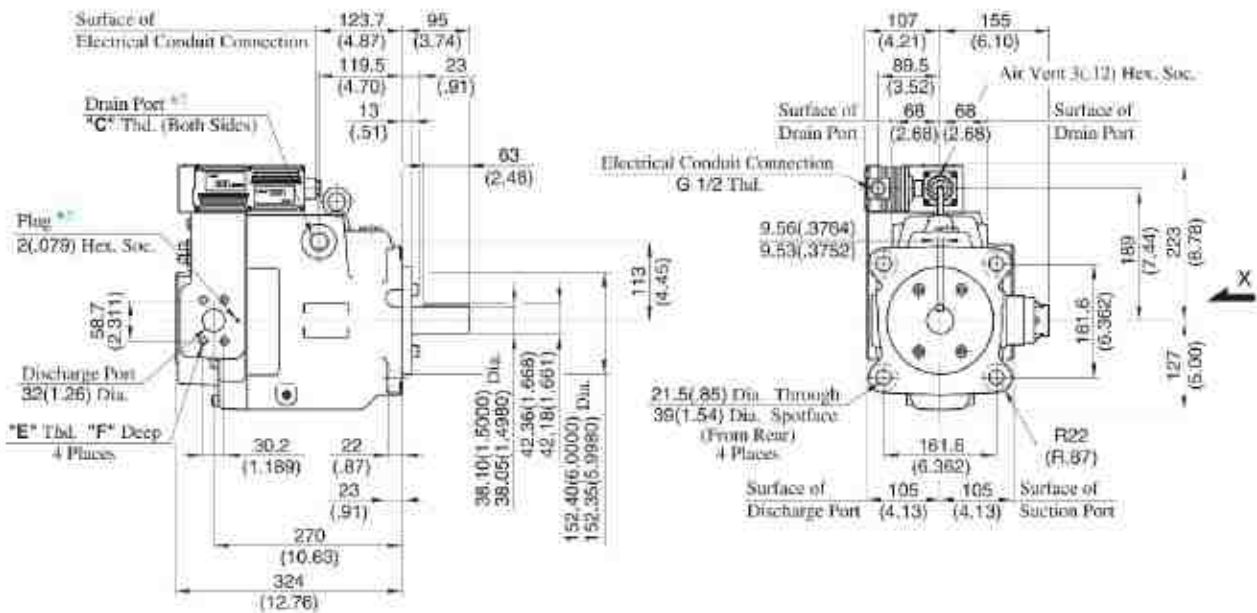

- Amplifier Direction "R" : A90-FR04EH*RS-*-60/60950

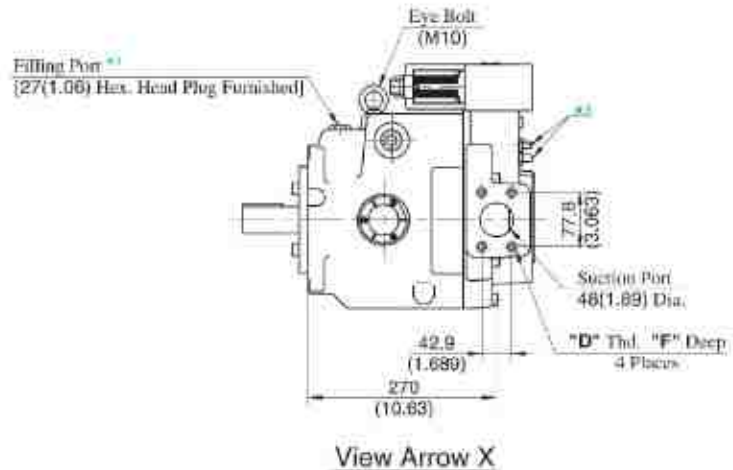
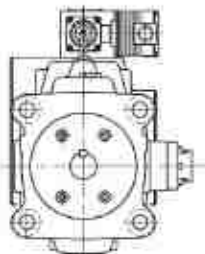

- ★ 1. Install the pump so that the "Filling Port" is at the top.
- ★ 2. Use either port of two drain parts at your option. Keep the remaining port plugged.
- ★ 3. Do not touch the screw because it is adjusted at the time of shipment.
- ★ 4. For detail of amplifier, refer to page 95.
- ★ 5. If you use the special sequence valve, remove the plug.

Model Numbers	"C" Thd.	"D" Thd.	"E" Thd.	Dimensions mm (IN.)
				F
A90-FR04EH**S-*-60	Rc 3/4	M12	M10	19 (.75)
A90-FR04EH**S-*-60950	SAE #12	1/2-13 UNC	7/16-14 UNC	21 (.83)

DIMENSIONS IN MILLIMETRES (INCHES)

● Foot Mounting Type

Mounting bracket is common to that of pressure compensator model. Refer to page 49 for the dimensions of mounting bracket.

Flange Mtg.

- Amplifier Direction "L" : A145-FR04EH*LS-*-60/60950

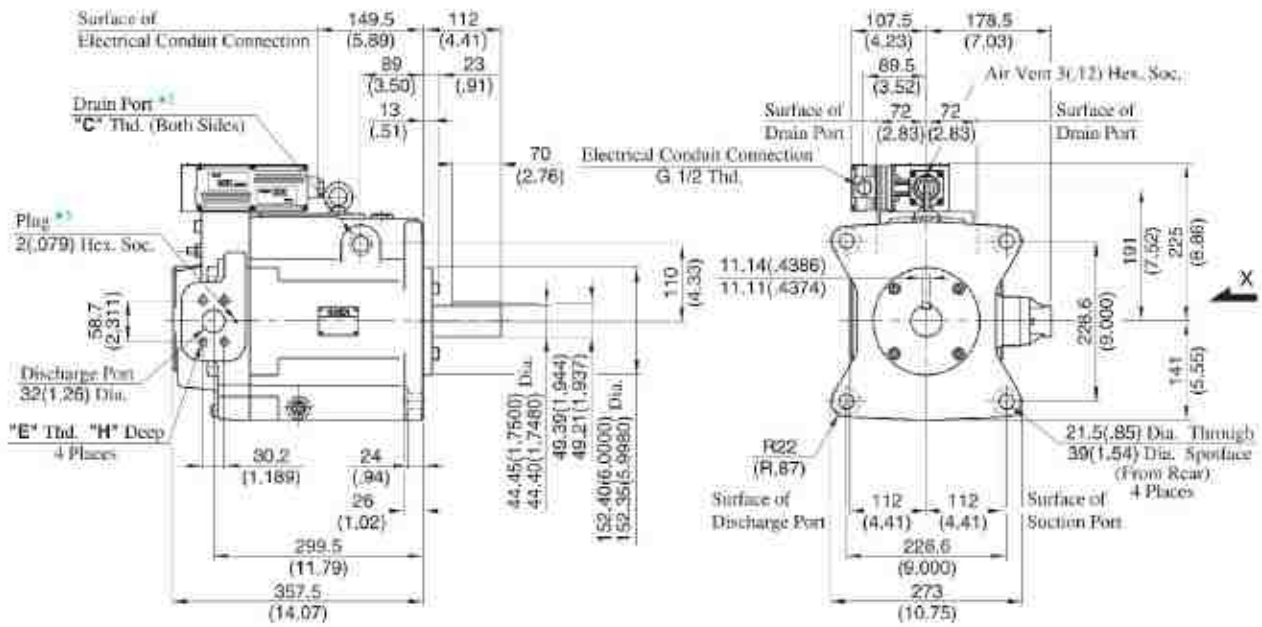

- Amplifier Direction "R" : A145-FR04EH*RS-*-60/60950

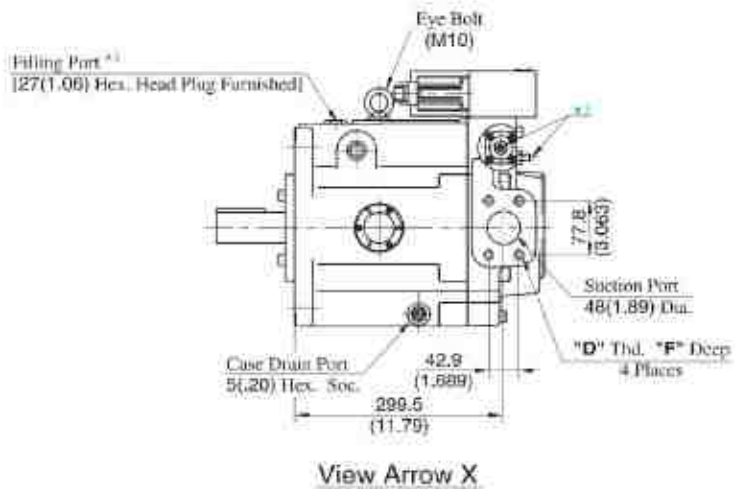
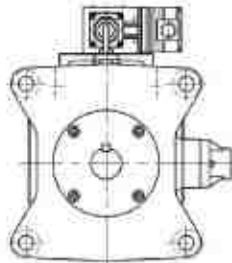

- ★ 1. Install the pump so that the "Filling Port" is at the top.
- ★ 2. Use either port of two drain ports at your option. Keep the remaining port plugged.
- ★ 3. Do not touch the screw because it is adjusted at the time of shipment.
- ★ 4. For detail of amplifier, refer to page 95.
- ★ 5. If you use the special sequence valve, remove the plug.

Model Numbers	"C" Thd.	"D" Thd.	"E" Thd.	Dimensions mm (IN.)	
				F	H
A145-FR04EH**S-*-60	Rc 3/4	M12	M10	19 (.75)	19 (.75)
A145-FR04EH**S-*-60950	SAE #12	1/2-13 UNC	7/16-14 UNC	21 (.83)	20 (.79)

DIMENSIONS IN MILLIMETRES (INCHES)

● **Foot Mounting Type**

Mounting bracket is common to that of pressure compensator model. Refer to page 50 for the dimensions of mounting bracket.



- Detail of Amplifier
- Connecting Terminal

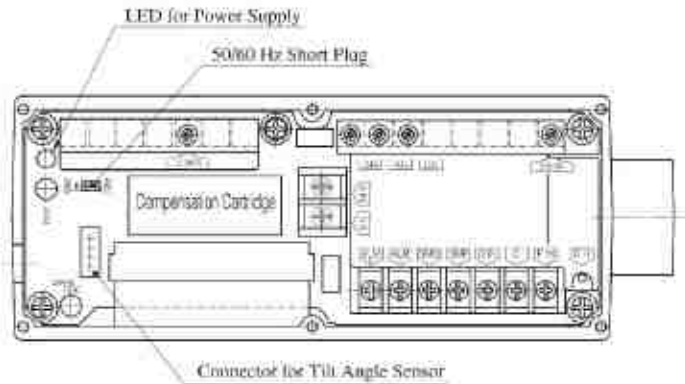

Terminal	Name
P IN	Input Signal, Pressure (+)
C	Input Signal (COM)
Q IN	Input Signal, Flow (+)
SMP	Sensor Monitor Output, Pressure
SMQ	Sensor Monitor Output, Tilt Angle
0 V	Power Supply
24 V	
ALM S	Alarm Output
ALM C	Alarm Output (COM)
CH	Output Current Check (to COM)

- Note 1. For "SENSOR MONITOR" terminal, external instruments should have input impedance of more than 10 kΩ.
2. For "CH" terminal, external instruments should have input impedance of more than 10 kΩ.
3. Volume adjustment of "DITHER", "GAIN", "CMG", "FMG" and "LQC" is made at the time of shipment. Adjustment at the customer is not required.
4. Use shielded cable for "Input" connection. The ground of the shielded cable must be connected to input signal side.

- Circuit Schematic

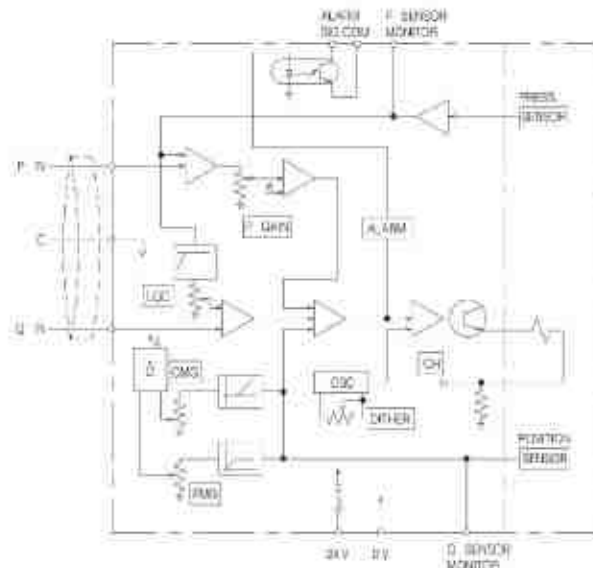

"A" Series Variable Displacement Piston Pumps – Single Pump, Pilot Pressure Control Type Pressure Compensator

Graphic Symbol

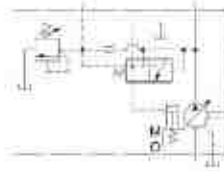

Performance Characteristics



Specifications

Model Numbers	Geometric Displacement cm ³ /rev (cu. in./rev)	Minimum Adj. Flow cm ³ /rev (cu. in./rev)	Operating Pressure MPa (PSI)		Minimum Adj. Pres. MPa (PSI)	Shaft Speed Range r/min		Approx. Mass kg (lbs.)	
			Rated ^{★1}	Intermittent ^{★2}		Max.	Min.	Flange Mtg.	Foot Mtg.
A10-FR07-12*	10.0 (.610)	2 (.122)	16 (2320)	21 (3050)	2.0 (290)	1800	600	8.5 (18.7)	10.7 (23.6)
A16-#-R-07-#-K-32*	15.8 (.964)	4 (.244)	16 (2320)	21 (3050)	1.2 (175)	1800	600	21 (46.3)	23.2 (51.2)
A22-#-R-07-#-K-32*	22.2 (1.355)	6 (.366)	16 (2320)	16 (2320)	1.2 (175)	1800	600	21 (46.3)	23.2 (51.2)
A37-#-R-07-#-K-32*	36.9 (2.25)	10 (.610)	16 (2320)	21 (3050)	1.2 (175)	1800	600	29 (63.9)	33.3 (73.4)
A56-#-R-07-#-K-32*	56.2 (3.43)	12 (.732)	16 (2320)	21 (3050)	1.2 (175)	1800	600	36 (79.4)	40.3 (88.9)
A70-#R07S-60*	70.0 (4.27)	30 (1.83)	25 (3630)	25 (3630)	2 (290)	1800	600	60.3 (133)	72.3 (159)
A90-#R07S-60*	91.0 (5.55)	56 (3.42)	25 (3630)	25 (3630)	2 (290)	1800	600	77.5 (171)	98 (216)
A145-#R07S-60*	145 (8.85)	83 (5.06)	25 (3630)	25 (3630)	2 (290)	1800	600	94 (207)	110 (262)

- ★1. Whenever setting pressure, make sure the full cut-off pressure never exceeds the maximum intermittent pressure.
- ★2. When operating the pump exceeding the rated pressure, operating conditions are restricted. Refer to page 33 for the details.



Model Number Designation

A16	-F	-R	-07	-S	-K	-32	*
Series Number	Mounting	Direction of Rotation	Control Type	Port Position	Shaft Extension	Design Number	Design Std.
A16 (15.8 cm ³ /rev)	F: Flange Mtg.	(Viewed from) Shaft End	07: Pilot Pressure Control Type Pressure Compensator	None: Axial Port S: Side Port	K: Keyed Shaft	32	Refer to*1
A22 (22.2 cm ³ /rev)						32	
A37 (36.9 cm ³ /rev)	L: Foot Mtg.	32					
A56 (56.2 cm ³ /rev)		32					

A70	-F	R	07	S	-60	*
Series Number	Mounting	Direction of Rotation	Control Type	Port Position	Design Number	Design Std.
A10 (10.0 cm ³ /rev)	F: Flange Mtg.*2	(Viewed from) Shaft End	07: Pilot Pressure Control Type Pressure Compensator	—	12	Refer to*1
A70 (70.0 cm ³ /rev)	F: Flange Mtg. L: Foot Mtg.				S: Side Port	
A90 (91.0 cm ³ /rev)		60				
A145 (145 cm ³ /rev)		60				

*1. Available to supply pump with anti-clockwise rotation. Consult Yuken for details.

*2. When A10 pump is used as the foot Mtg., order the Mtg. Bracket kit shown below separately. Refer to page 24 for dimensions of the Mtg. bracket.

Mtg. Bracket Kit Numbers	Approx. Mass kg (lbs.)
LP-1A-10	2.2 (4.9)

Note: The mounting bracket kit consists of a mounting bracket, 2 hex. bolts and 2 plain washer.

*3. Design Standards: None Japanese Standard "JIS"
80 European Design Standard
950 N. American Design Standard

Performance Characteristics

For performance characteristics, refer to models of pressure compensator type on page 36 to 43.

Pipe Flange Kit

For pipe flange, refer to form of pressure compensator type on page 34.

Flange Mtg.

DIMENSIONS IN MILLIMETRES (INCHES)

• Japanese Standard "JIS" : A10-FR07-12

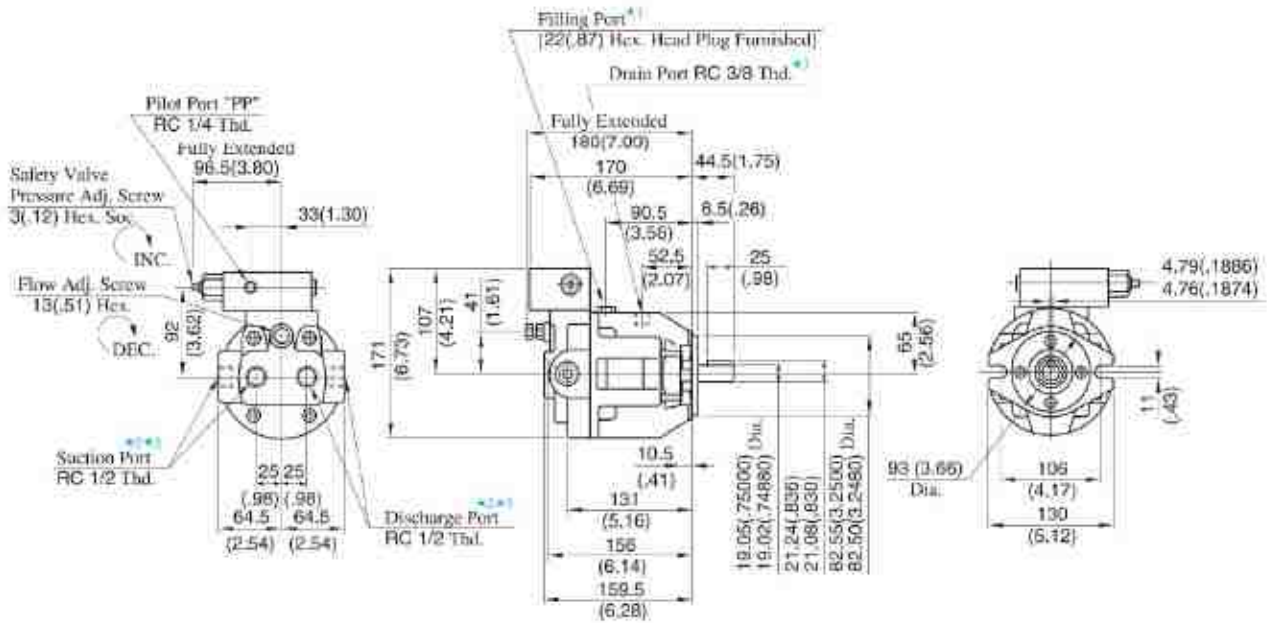

- European Design Standard : A10-FR07-1280
- N. American Design Standard : A10-FR07-12950

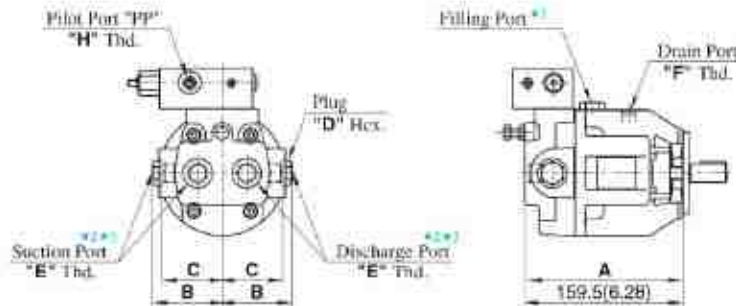

Model Numbers	Dimensions mm (IN.)				Thread Size		
	A	B	C	D	E	F	h
A10-FR07-1280	159 (6.26)	72 (2.83)	64 (2.52)	22 (.87)	1/2 BSP. F	3/8 BSP. F	1/4 BSP. Tr
A10-FR07-12950	157 (6.18)	71 (2.80)	62 (2.44)	27 (1.06)	SAE #8	SAE #6	SAE #4

• For other dimensions, refer to Japanese Standard "JIS".

- ★ 1. Install the pump so that the "Filling Port" is at the top.
- ★ 2. Use either port of two suction and discharge ports at your option. Keep the remaining ports plugged.
- ★ 3. As the tightening torques of suction, discharge and drain port fittings, conform to the below.

Model Numbers	Tightening Torque Nm (IN. lbs.)	
	Suction Port & Discharge Port	Drain Port
A70-FR07-12	65-75 (575-664)	40-50 (354-443)
A70-FR07-1280	56-62 (496-549)	33-36 (292-319)
A70-FR07-12950	47-51 (416-451)	40-50 (354-443)



Axial Port Type

Flange Mtg. : A16-F-R-07-K-32/3280/32950
A22-F-R-07-K-32/3280/32950

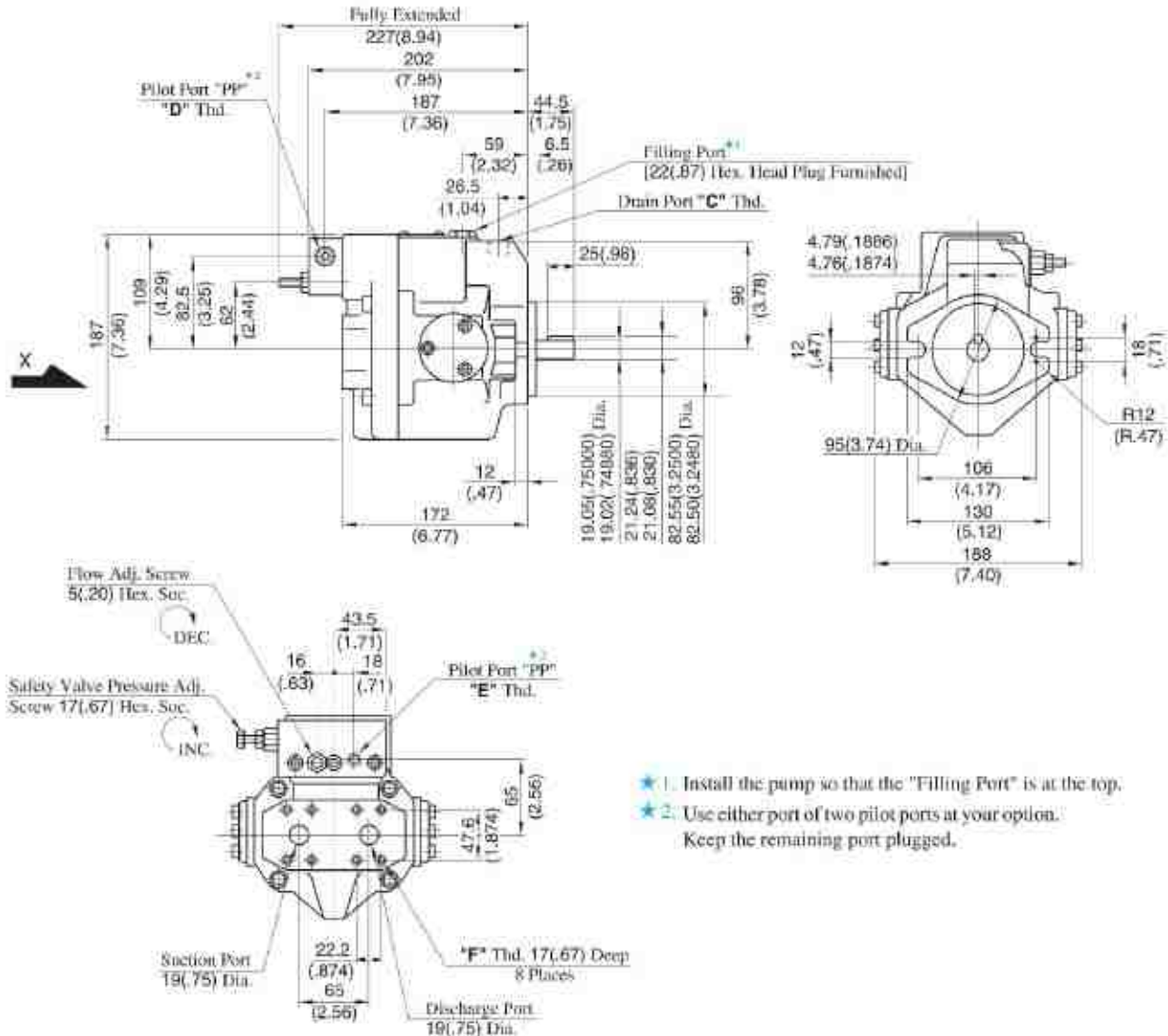

View Arrow X

Model Numbers	"C" Thd.	"D" Thd.	"E" Thd.	"F" Thd.
A16/A22-F-R-07-K-32	Rc 3/8	Rc 3/8	Rc 1/4	M10
A16/A22-F-R-07-K-3280	3/8 BSP. F	3/8 BSP. F	1/4 BSP. Tr	
A16/A22-F-R-07-K-32950	SAE #8	SAE #6	SAE #4	3/8-16 UNC

- ★ 1. Install the pump so that the "Filling Port" is at the top.
- ★ 2. Use either port of two pilot ports at your option. Keep the remaining port plugged.

DIMENSIONS IN MILLIMETRES (INCHES)

● Axial Port Type

Port mounting dimensions are the same as those of pressure compensator model. Refer to page 45 for port mounting dimensions.

● Foot Mounting Type

Mounting bracket is common to that of pressure compensator model. Refer to page 45 for the dimensions of mounting bracket.

Side Port Type

Flange Mtg. : A37-F-R-07-S-K-32/3280/32950

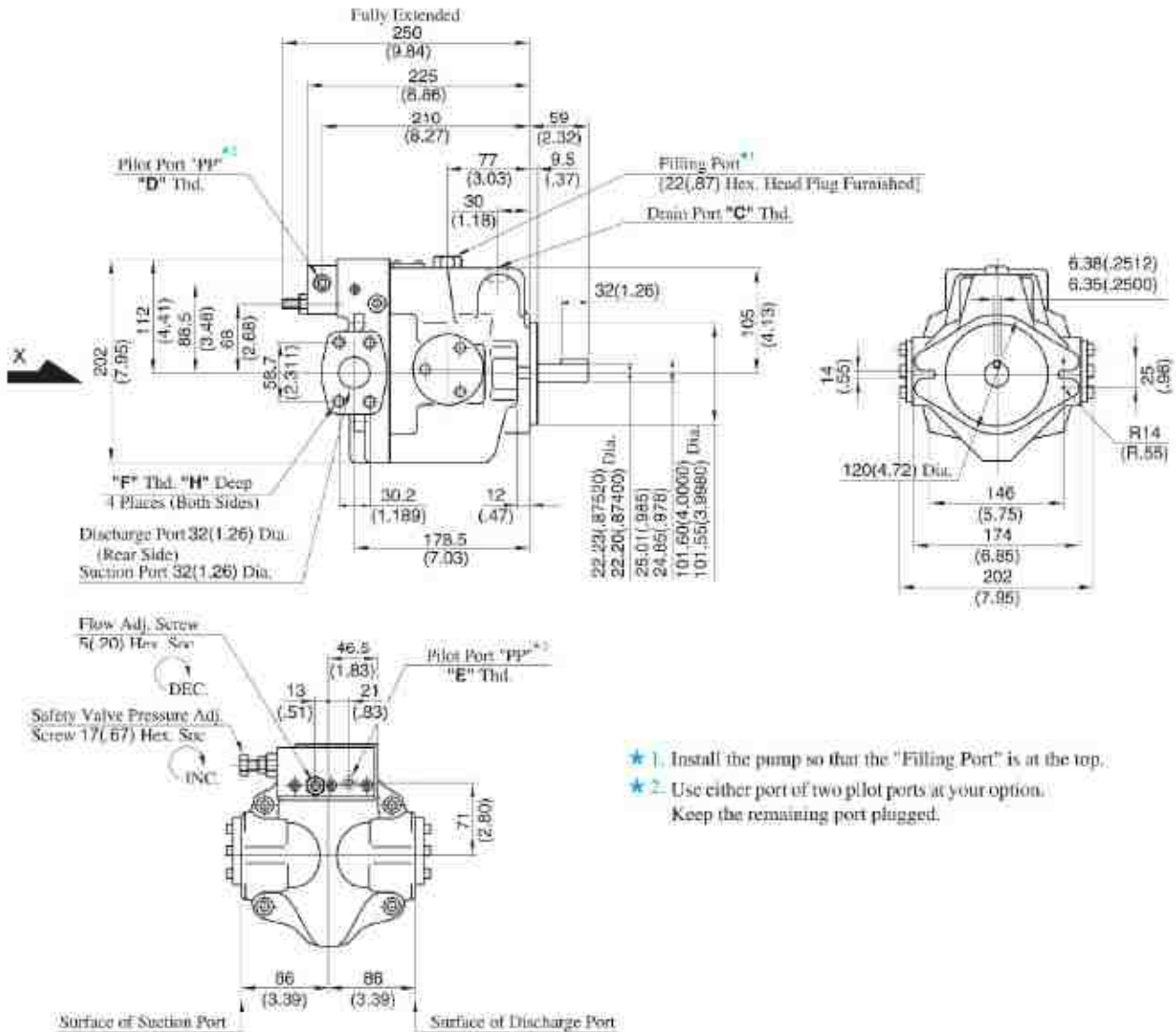

- ★ 1. Install the pump so that the "Filling Port" is at the top.
- ★ 2. Use either port of two pilot ports at your option. Keep the remaining port plugged.

View Arrow X

Model Numbers	"C" Thd.	"D" Thd.	"E" Thd.	"F" Thd.	"H" mm (IN.)
A37-F-R-07-S-K-32	Rc 1/2	Rc 3/8	Rc 1/4	M10	19 (.75)
A37-F-R-07-S-K-3280	1/2 BSP.F	3/8 BSP.F	1/4 BSP.TY		
A37-F-R-07-S-K-32950	SAE #10	SAE #6	SAE #4	7/16-14 UNC	20 (.79)

DIMENSIONS IN MILLIMETRES (INCHES)

● **Axial Port Type**

Port mounting dimensions are the same as those of pressure compensator model. Refer to page 46 for port mounting dimensions.

● **Foot Mounting Type**

Mounting bracket is common to that of pressure compensator model. Refer to page 46 for the dimensions of mounting bracket.

Side Port Type

Flange Mtg. : A56-F-R-07-S-K-32/3280/32950

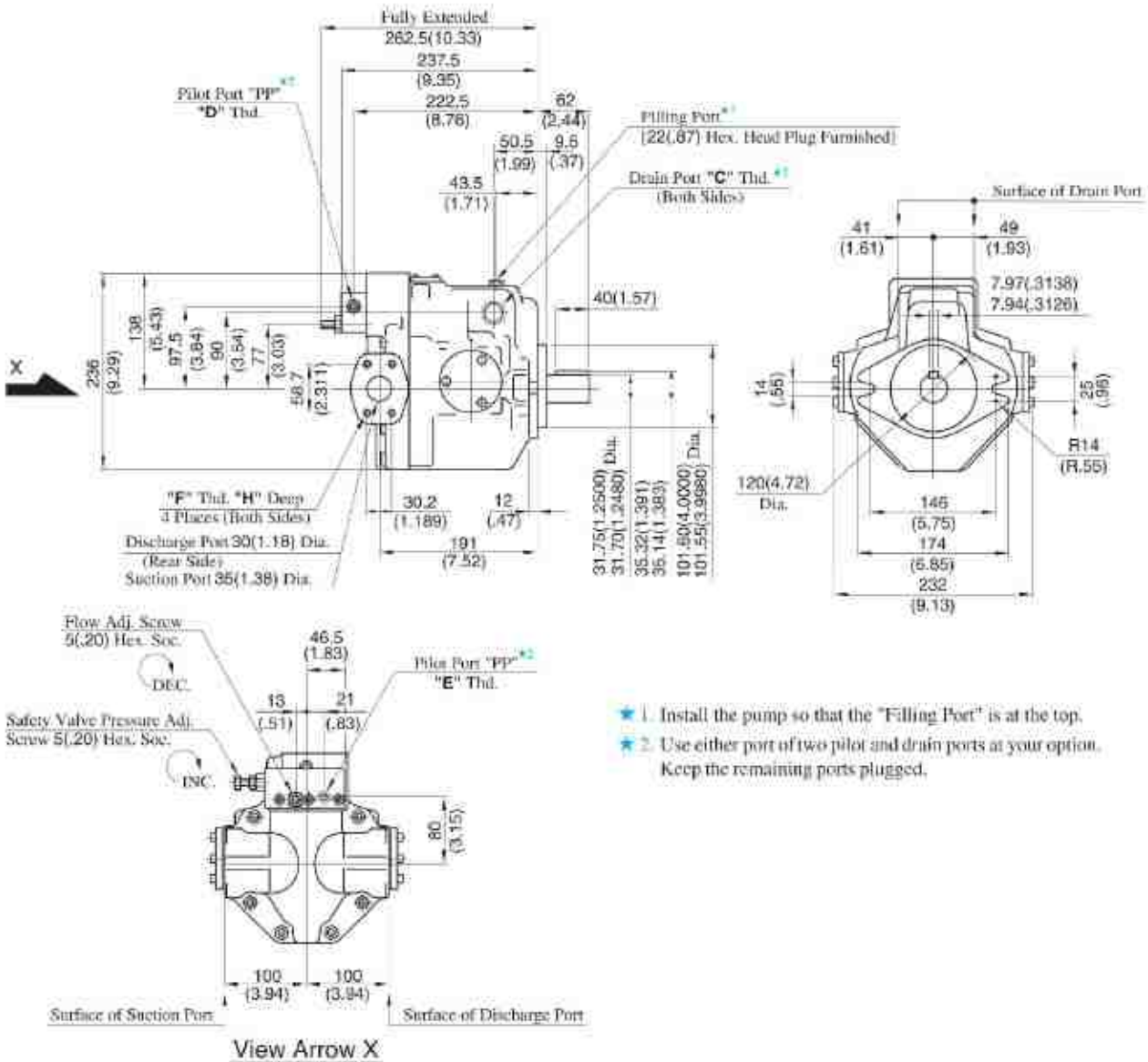

- ★ 1. Install the pump so that the "Filling Port" is at the top.
- ★ 2. Use either port of two pilot and drain ports at your option. Keep the remaining ports plugged.

DIMENSIONS IN MILLIMETRES (INCHES)

● Axial Port Type

Port mounting dimensions are the same as those of pressure compensator model. Refer to page 47 for port mounting dimensions.

● Foot Mounting Type

Mounting bracket is common to that of pressure compensator model. Refer to page 47 for the dimensions of mounting bracket.

Flange Mtg. : A70-FR07S-60/6080/60950

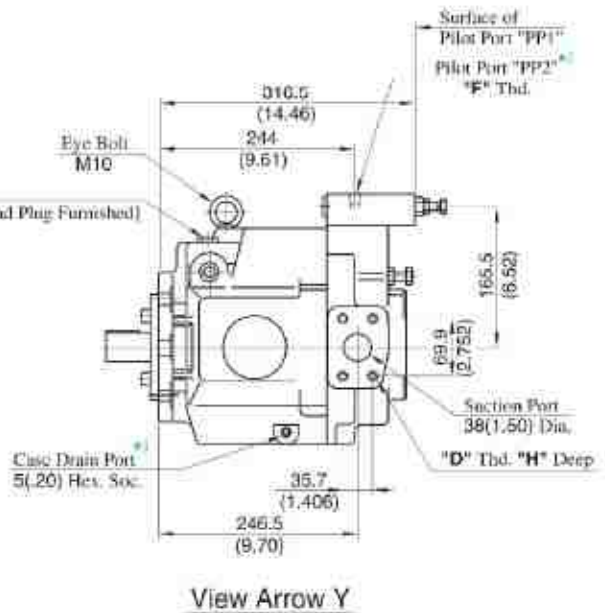
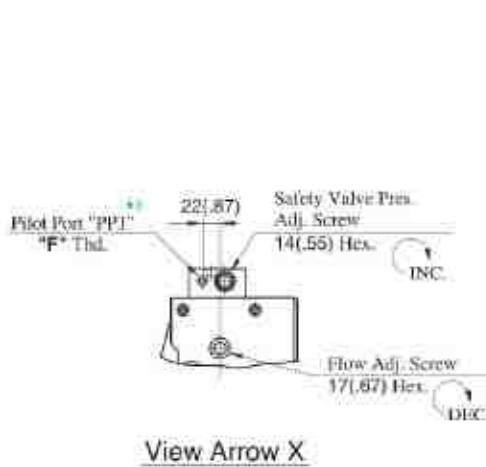
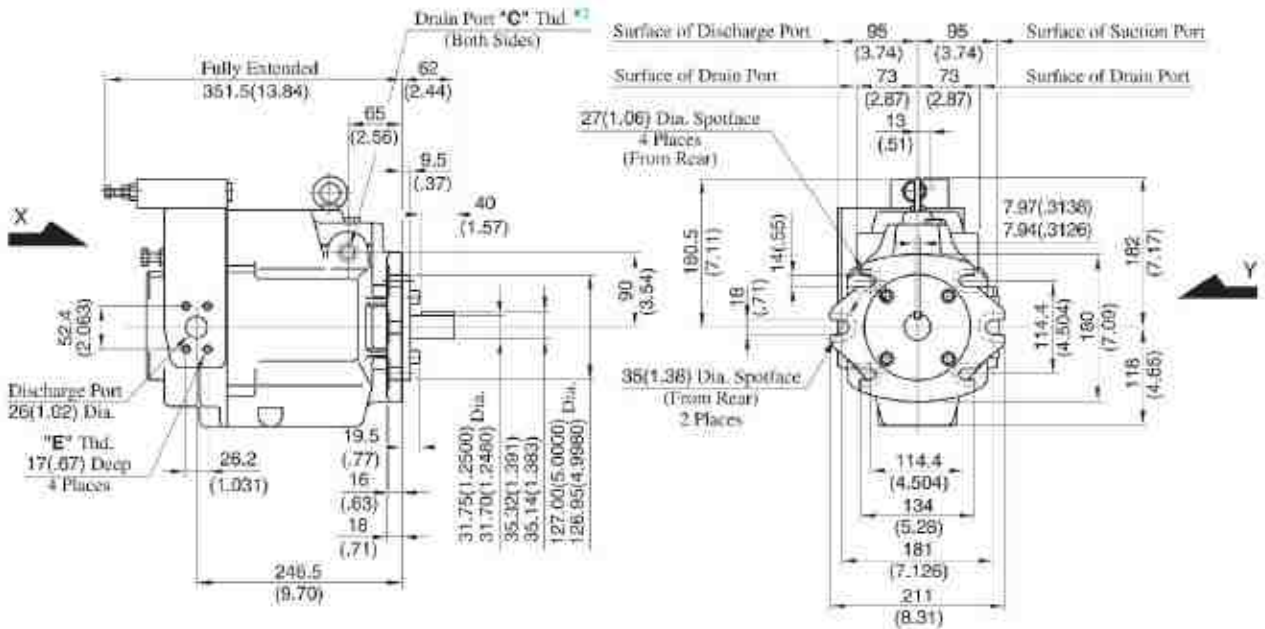

- ★ 1. Install the pump so that the "Filling Port" is at the top.
- ★ 2. Use either port of two pilot and drain ports at your option. Keep the remaining ports plugged.
- ★ 3. Case drain port is available for use when draining hydraulic fluid from pump casing.

Model Numbers	"C" Thd.	"D" Thd.	"E" Thd.	"F" Thd.	"H" mm (IN.)
A70-FR07S-60	Rc 3/4	M12	M10	Rc 1/4	19 (.75)
A70-FR07S-6080	3/4 BSP,F	M12	M10	1/4 BSP, Tr	19 (.75)
A70-FR07S-60950	SAE #12	1/2-13 UNC	3/8-16 UNC	SAE #-	21 (.83)

DIMENSIONS IN MILLIMETRES (INCHES)

● **Foot Mounting Type**

Mounting bracket is common to that of pressure compensator model. Refer to page 48 for the dimensions of mounting bracket.

Flange Mtg. : A90-FR07S-60/6080/60950

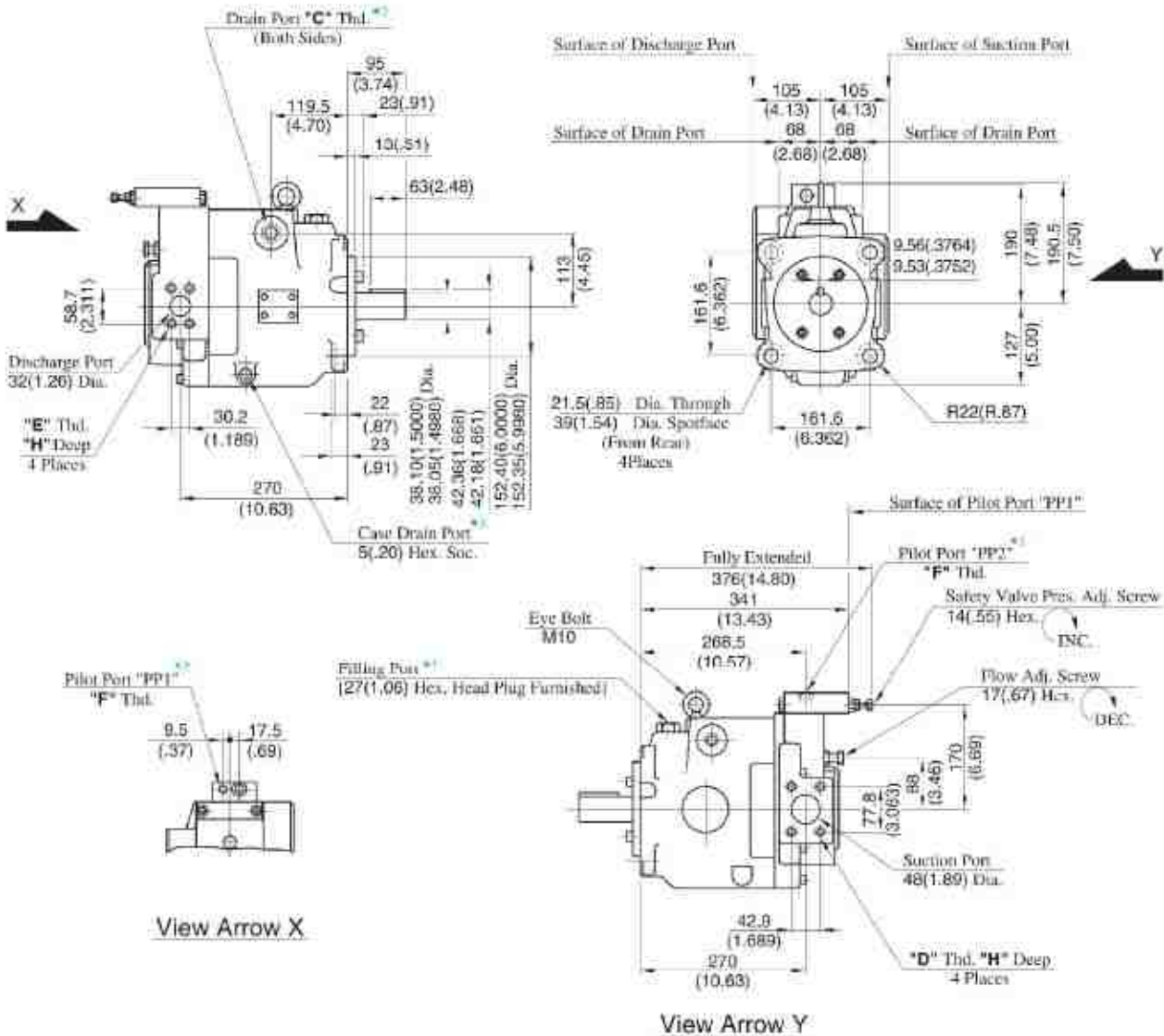

- ★ 1. Install the pump so that the "Filling Port" is at the top.
- ★ 2. Use either port of two pilot and drain ports at your option. Keep the remaining ports plugged.
- ★ 3. Case drain port is available for use when draining hydraulic fluid from pump casing.

Model Numbers	"C" Thd.	"D" Thd.	"E" Thd.	"F" Thd.	H mm (IN.)
A90-FR07S-60	Rc 3/4	M12	M10	Rc 1/4	19 (.75)
A90-FR07S-6080	3/4 BSP.F			1/4 BSP. Tr	
A90-FR07S-60950	SAE #12	1/2-13 UNC	7/16-14 UNC	SAE #4	21 (.83)

DIMENSIONS IN MILLIMETRES (INCHES)

● **Foot Mounting Type**

Mounting bracket is common to that of pressure compensator model. Refer to page 49 for the dimensions of mounting bracket.

Flange Mtg. : A145-FR07S-60/6080/60950

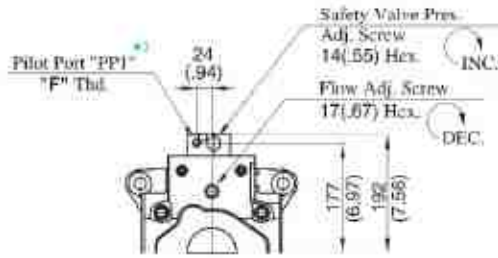
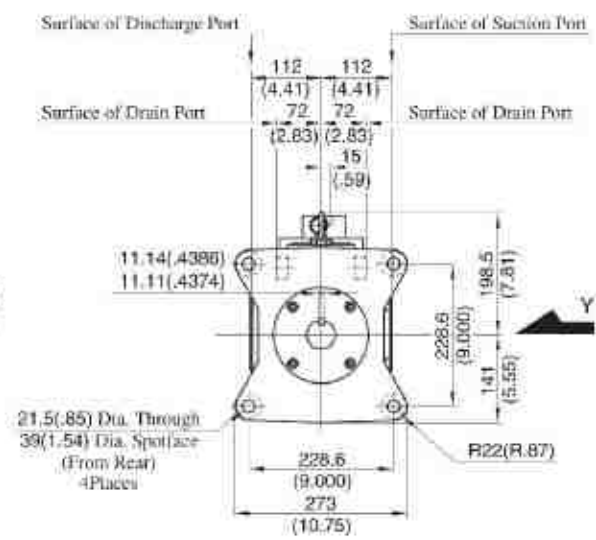
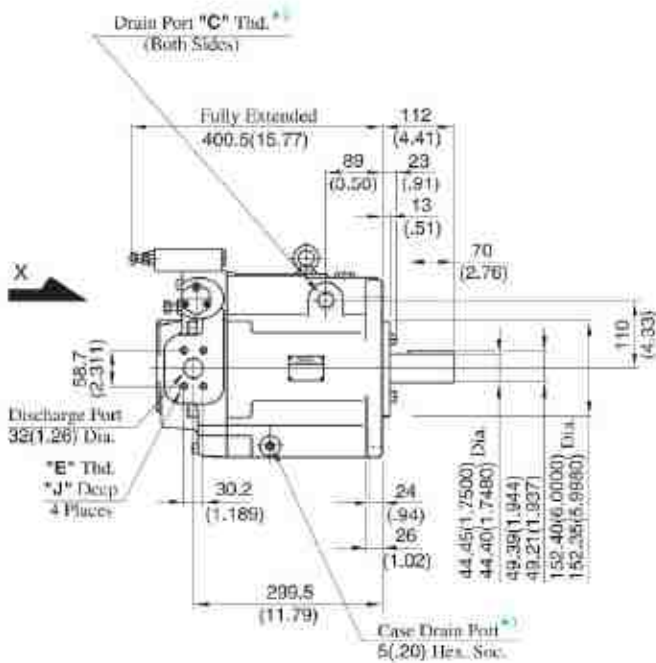

View Arrow X

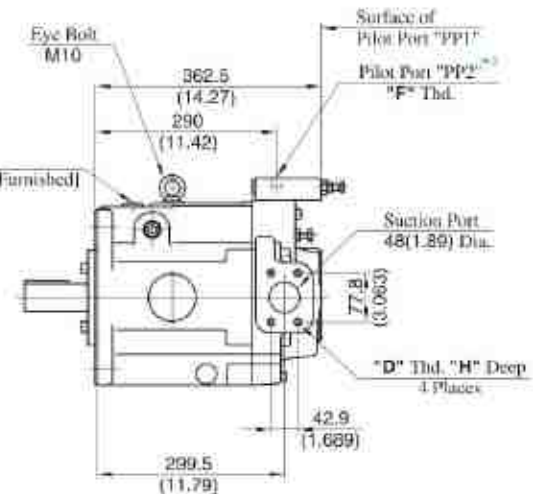

View Arrow Y

- ★ 1. Install the pump so that the "Filling Port" is at the top.
- ★ 2. Use either port of two pilot and drain ports at your option. Keep the remaining ports plugged.
- ★ 3. Case drain port is available for use when draining hydraulic fluid from pump casing.

Model Numbers	"C" Thd.	"D" Thd.	"E" Thd.	"F" Thd.	H mm (IN.)	J mm (IN.)
A145-FR07S-60	Re 3/4	M12	M10	Re 1/4	19 (.75)	19 (.75)
A145-FR07S-6080	3/4 BSP.F			1/4 BSP. Tr		
A145-FR07S-60950	SAE #12	1/2-13 UNC	7/16-14 UNC	SAE #4	21 (.83)	20 (.79)

DIMENSIONS IN MILLIMETRES (INCHES)

● **Foot Mounting Type**

Mounting bracket is common to that of pressure compensator model. Refer to page 50 for the dimensions of mounting bracket.



"A" Series Variable Displacement Piston Pumps – Single Pump, Constant Power Control Type



Performance Characteristics

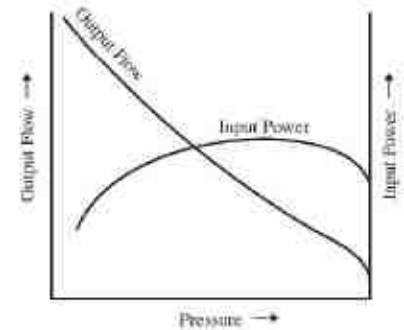

Graphic Symbols



A16

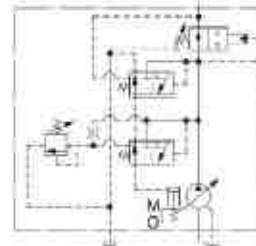

A37/A56

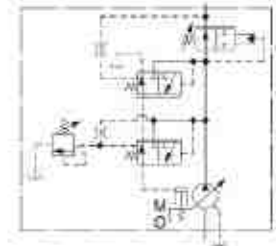

A70/A145

Specifications

Model Numbers	Geometric Displacement cm ³ /rev (cu. in./rev)	Minimum ^{★2} Adj. Flow cm ³ /rev (cu. in./rev)	Operating Pres. MPa (PSI)	Shaft Speed Range r/min		Approx. Mass kg (lbs.)	
			Max.	Max.	Min.	Flange Mtg.	Foot Mtg.
A16-#-R-09-#-#-K-32#	15.8 (.964)	—	21 (3050) ^{★1}	1800	600	29.0 (63.9)	31.2 (68.8)
A37-#-R-09-#-#-K-32#	36.9 (2.25)	—	21 (3050) ^{★1}	1800	600	37.0 (81.6)	41.3 (91.1)
A56-#-R-09-#-#-K-32#	56.2 (3.43)	—	21 (3050) ^{★1}	1800	600	44.0 (97.0)	48.3 (107)
A70-#R09#S-60#	70.0 (4.27)	30 (.295)	25 (3630)	1800	600	72.8 (161)	84.8 (187)
A145-#R09#S-60#	145 (8.85)	83 (5.06)	25 (3630)	1800	600	110 (243)	135 (298)

★1. Maximum Operating Pressure of A16/A37/A56 varies according to Input Power Setting. See Model Number Designation for details.

★2. Minimum Adjustment Flow of A70/A145 is absolutely minimum flow that can be adjusted with Flow Adjustment Screw.

A90 type pump (91 cm³/rev) is available. Ask Yuken for Details.

■ Model Number Designation

● A16/A37/A56

A16	-F	-R	-09	-A		-16M	-K	-32	*
Series Number	Mounting	Direction of Rotation	Control Type	Input Power Setting		Specify Control Pres.*2	Shift Extension	Design Number	Design Std.
A16 (15.8 cm ³ /rev)	F: Flange Mtg. L: Foot Mtg.	(Viewed from Shaft End) R: Clockwise*1 (Normal)	09: Constant Power Control Type	A: 3.7 kW (5 HP)	E: 2.2 kW (3 HP)	7M : 7 MPa (1020 PSI) 10.5M : 10.5 MPa (1520 PSI) 14M : 14 MPa (2030 PSI) 16M : 16 MPa (2320 PSI) 17.5M : 17.5 MPa (2540 PSI) 21M : 21 MPa (3050 PSI)	K: Keyed Shaft	32	Refer to ★3
B: 5.5 kW (7.5 HP)				F: 1.5 kW (2 HP)					
A: 3.7 kW (5 HP)				C: 7.5 kW (10 HP)					
A37 (36.9 cm ³ /rev)				B: 5.5 kW (7.5 HP)	D: 11 kW (15 HP)				
A56 (56.2 cm ³ /rev)				C: 7.5 kW (10 HP)	G: 22 kW (30 HP)				
				D: 11 kW (15 HP)					

● A70/A145

A70	-F	R	09	A		S	-60	*
Series Number	Mounting	Direction of Rotation	Control Type	Input Power Setting		Direction of Port	Design Number	Design Std.
A70 (70 cm ³ /rev)	F: Flange Mtg. L: Foot Mtg.	(Viewed from Shaft End) R: Clockwise*1 (Normal)	09: Constant Power Control Type	A: 15 kW (20 HP)	E: 22 kW (30 HP)	S: Side Port	60	Refer to ★3
A145 (145 cm ³ /rev)				B: 18.5 kW (25 HP)	F: 30 kW (40 HP)			
				A: 15 kW (20 HP)	E: 37 kW (50 HP)			
				B: 18.5 kW (25 HP)	F: 45 kW (60 HP)			
				C: 22 kW (30 HP)	G: 55 kW (75 HP)			
				D: 30 kW (40 HP)	H: 75 kW (100 HP)			

★1. Available to supply pump with anti-clockwise rotation. Consult Yuken for details.

★2. Specify control pressure of A16/A37/A56 with lower than Maximum Operating Pressure depending on Input Power Setting.

Model	Maximum Operating Pressure MPa (PSI)								
	1.5 kW (2 HP)	2.2 kW (3 HP)	3.7 kW (5 HP)	5.5 kW (7.5 HP)	7.5 kW (10 HP)	11 kW (15 HP)	15 kW (20 HP)	18.5 kW (25 HP)	22 kW (30 HP)
A16	10.5 (1520)	16 (2320)	21 (3050)	21 (3050)	—	—	—	—	—
A37	—	—	16 (2320)	21 (3050)	21 (3050)	21 (3050)	—	—	—
A56	—	—	10.5 (1520)	14 (2030)	17.5 (2540)	21 (3050)	21 (3050)	21 (3050)	21 (3050)

★3. Design Standards: None Japanese Standard "JIS"
80 European Design Standard
950 N. American Design Standard

■ Pipe Flange Kits

Pipe flange kits are available. When ordering, specify the kit number from the table below.

Pump Model Numbers	Name of Port	Pipe Flange Kit Numbers						
		Threaded Connection			Socket Welding*		Butt Welding	
		Japanese Std. "JIS"	European Design Std.	N. American Design Standard	Japanese Std. "JIS" & European Design Std.	N. American Design Standard	Japanese Std. "JIS" & European Design Std.	N. American Design Standard
A16-★-R-09	Suction	F5-06-A-10	F5-06-A-1080	—	F5-06-B-10	F5-06-B-1090	F5-06-C-10	F5-06-C-1090
	Discharge	—	—	—	—	—	—	—
A37-★-R-09	Suction	F5-10-A-10	F5-10-A-1080	—	F5-10-B-10	F5-10-B-1090	F5-10-C-10	F5-10-C-1090
	Discharge	F5-06-A-10	F5-06-A-1080	—	F5-06-B-10	F5-06-B-1090	F5-06-C-10	F5-06-C-1090
A56-★-R-09	Suction	F5-12-A-10	F5-12-A-1080	—	F5-12-B-10	F5-12-B-1090	F5-12-C-10	F5-12-C-1090
	Discharge	F5-08-A-10	F5-08-A-1080	—	F5-08-B-10	F5-08-B-1090	F5-08-C-10	F5-08-C-1090
A70-★-R-09	Suction	F5-16-A-10	F5-16-A-1080	—	F5-16-B-10	F5-16-B-1090	F5-16-C-10	F5-16-C-1090
	Discharge	F5-10-A-10	F5-10-A-1080	—	F5-10-B-10	F5-10-B-1090	F5-10-C-10	F5-10-C-1090

★1. In case of using socket welding flanges, there is a case where the operating pressure should be set lower than the normal because of strength of hat flanges. Therefore, please pay cautious attention to the operating pressure when the socket welding flanges are used.

★2. Discharge port for pump model "A16" is available only the threaded connections.

★3. As dimensions of the pipe flange mounting surface are conformed to SAE 4 Bolt Split Flange (Standard Pressure Series), pipe flanges conforming to the SAE Standards can be used.

• Detail of the pipe flange kits are shown on page 824.



Typical Performance Characteristics at 1500 r/min

A16

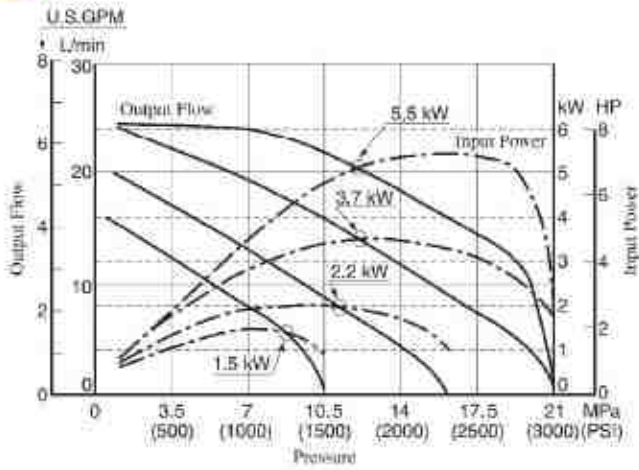

A70

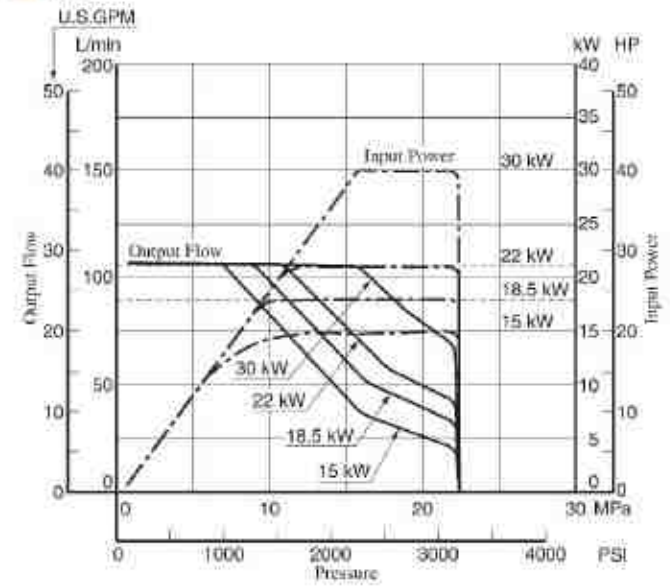

A37

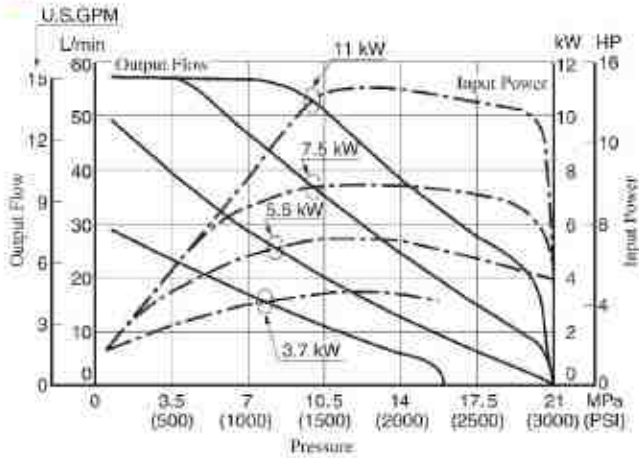

A145

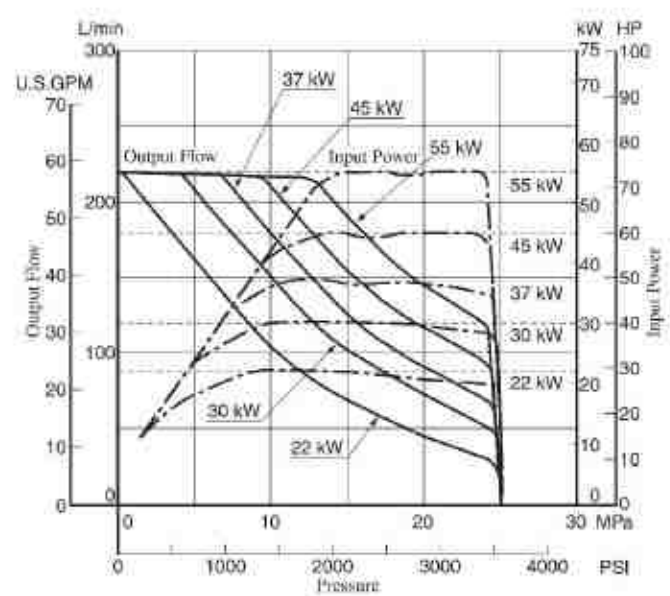

A56

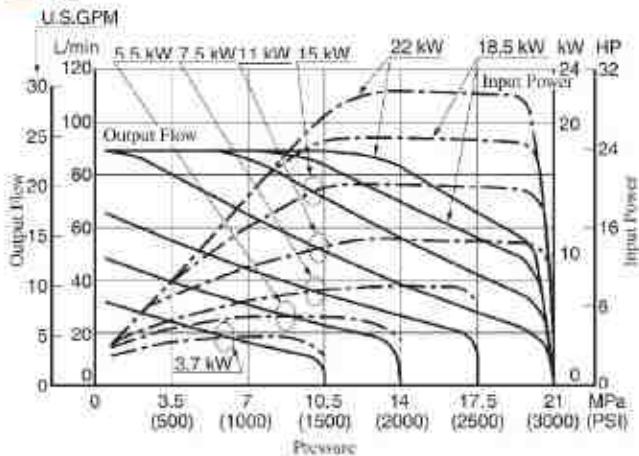

Flange Mfg. : A16-F-R-09-#-K-32/3280/32950

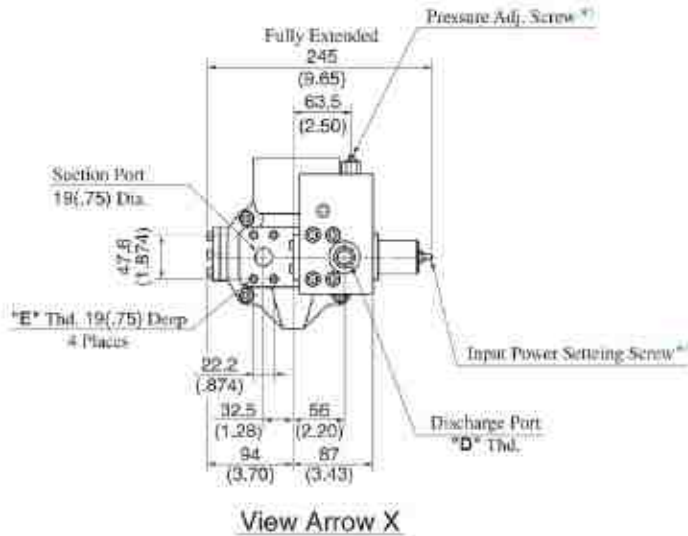
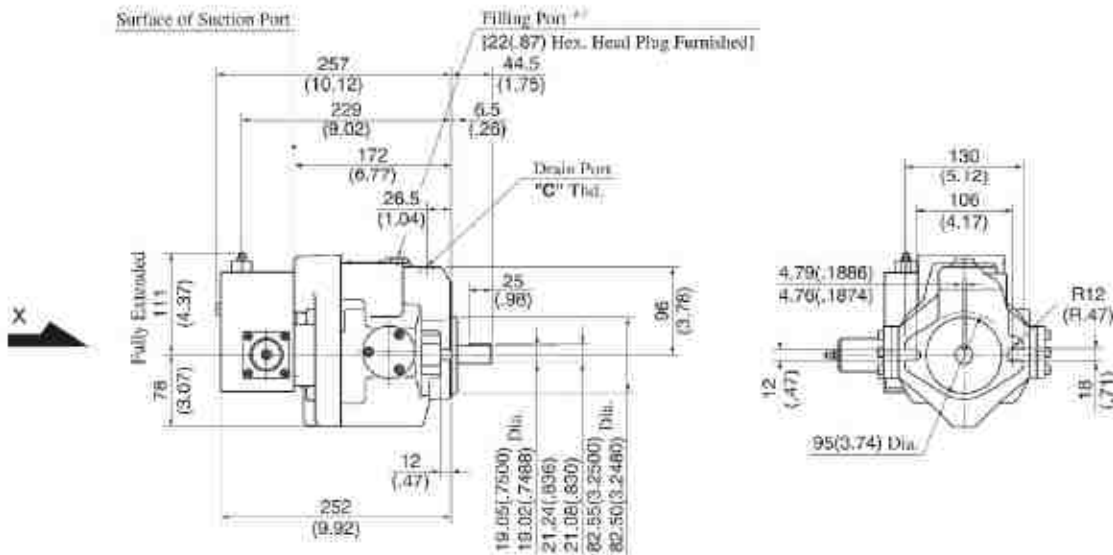

Model Numbers	"C" Thd.	"D" Thd.	"E" Thd.
A16-F-R-09-#-K-32	Rc 3/8	G 1/2 ^{★1}	M10
A16-F-R-09-#-K-3280	3/8 BSP.F	1/2 BSP.F	
A16-F-R-09-#-K-32950	SAE #8	SAE #8	3/8-16 UNC

★ 1. Detail of Discharge Port
[For Japanese Standard]

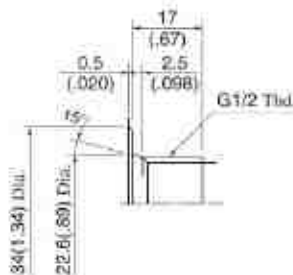

★ 2. Install the pump so that the "Filling Port" is at the top.
★ 3. Do not touch the screw because it is adjusted at the time of shipment.

**DIMENSIONS IN
MILLIMETRES (INCHES)**

● **Foot Mounting Type**

Mounting bracket is common to that of pressure compensator model.
Refer to page 45 for the dimensions of mounting bracket.

Flange Mtg. : A37-F-R-09-***-K-32/3280/32950

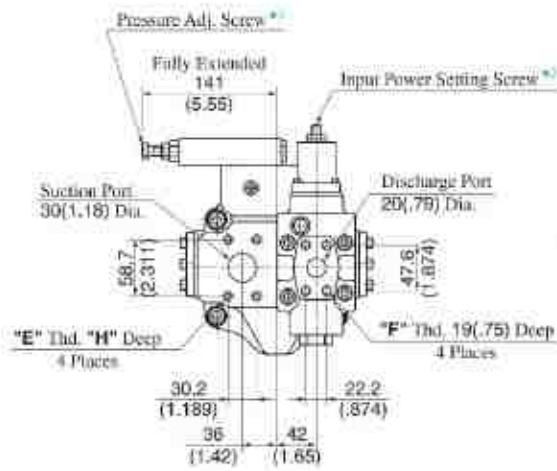
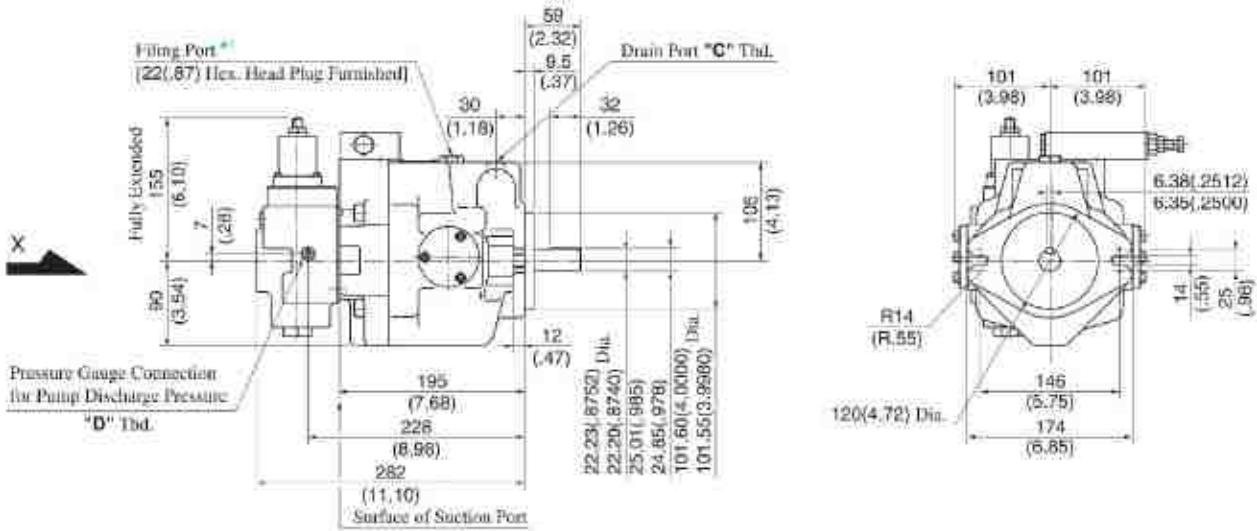

- ★ 1. Install the pump so that the "Filling Port" is at the top.
- ★ 2. Do not touch the screw because it is adjusted at the time of shipment.

Model Numbers	*C* Thd.	*D* Thd.	*E* Thd.	*F* Thd.	*H* mm (IN.)
A37-F-R-09- <i>*</i> -K-32	Rc 1/2	Rc 1/4	M10	M10	19 (.75)
A37-F-R-09- <i>*</i> -K-3280	1/2 BSP.F	1/4 BSP.Tr			
A37-F-R-09- <i>*</i> -K-32950	SAE #10	SAE #4	7/16-14 UNC	3/8-16 UNC	20 (.79)

DIMENSIONS IN MILLIMETRES (INCHES)

Foot Mtg. : A37-L-R-09-***-K-32/3280/32950

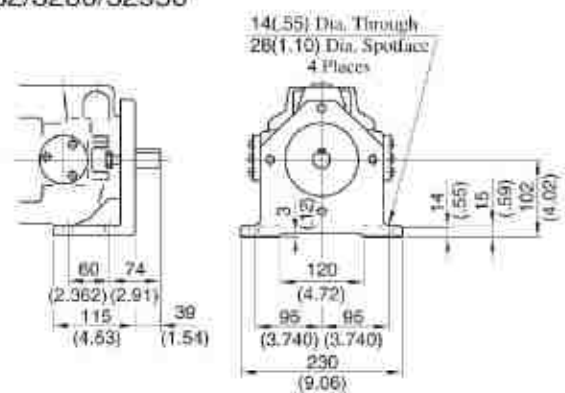

* For other dimensions, refer to "Flange Mtg."

Flange Mtg. : A56-F-R-09- \ast -K-32/3280/32950

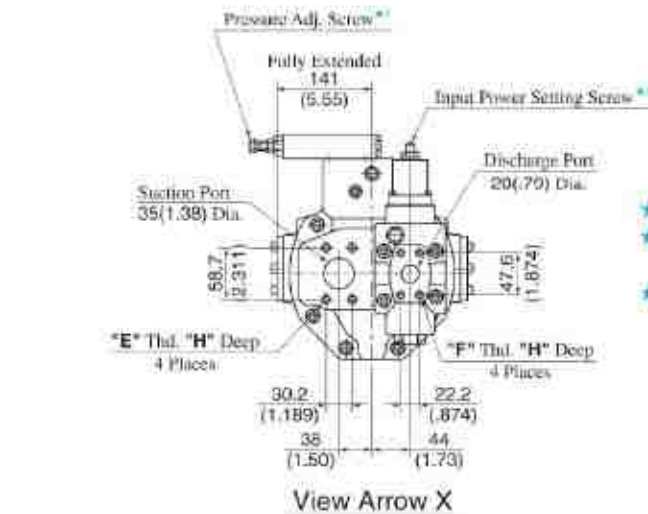
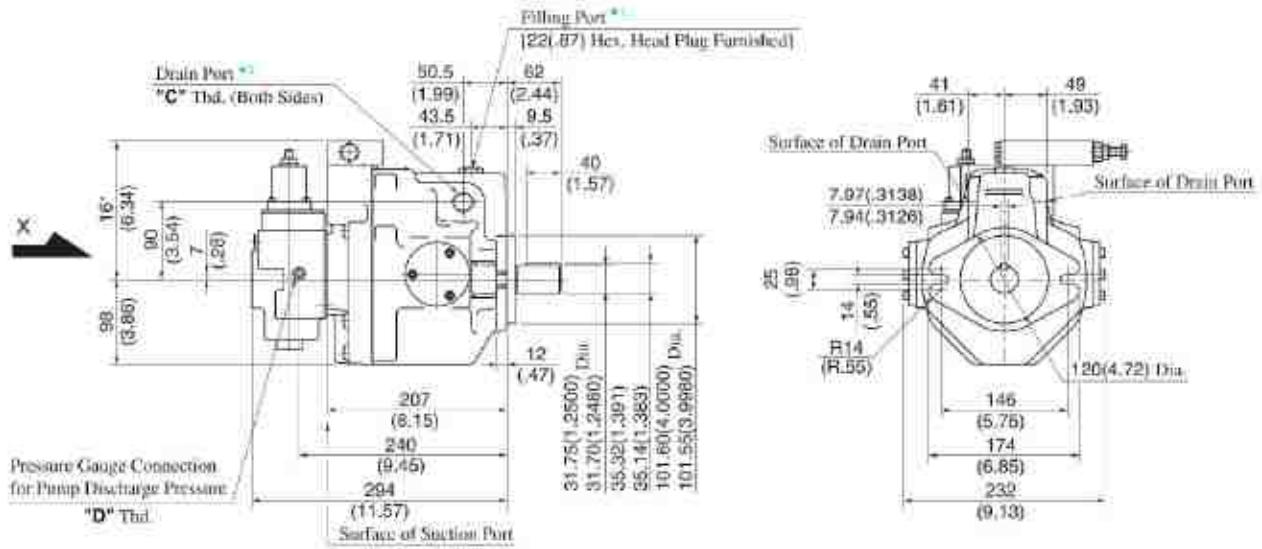

- ★ 1. Install the pump so that the "Filling Port" is at the top.
- ★ 2. Use either port of two drain ports at your option. Keep the remaining port plugged.
- ★ 3. Do not touch the screw because it is adjusted at the time of shipment.

Model Numbers	"C" Thd.	"D" Thd.	"E" Thd.	"F" Thd.	"H" mm (IN.)
A56-F-R-09- \ast -K-32	Rc 3/4	Rc 1/4	M10	M10	19 (.75)
A56-F-R-09- \ast -K-3280	3/4 BSP.F	1/4 BSP.Ty			
A56-F-R-09- \ast -K-32950	SAE #12	SAE #4	7/16-14 UNC	3/8-16 UNC	20 (.79)

DIMENSIONS IN MILLIMETRES (INCHES)

Foot Mtg. : A56-L-R-09- \ast -K-32/3280/32950

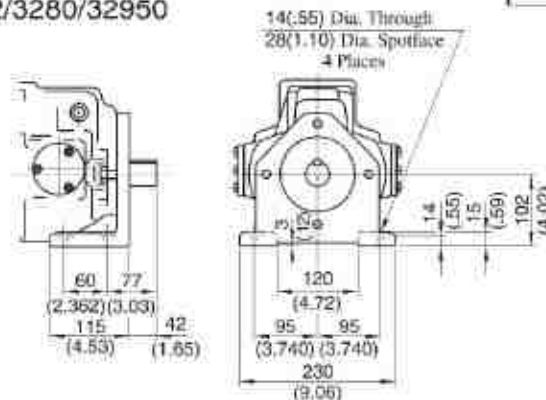

★ For other dimensions, refer to "Flange Mtg."

Flange Mtg. : A70-FR09*S-60/6080/60950

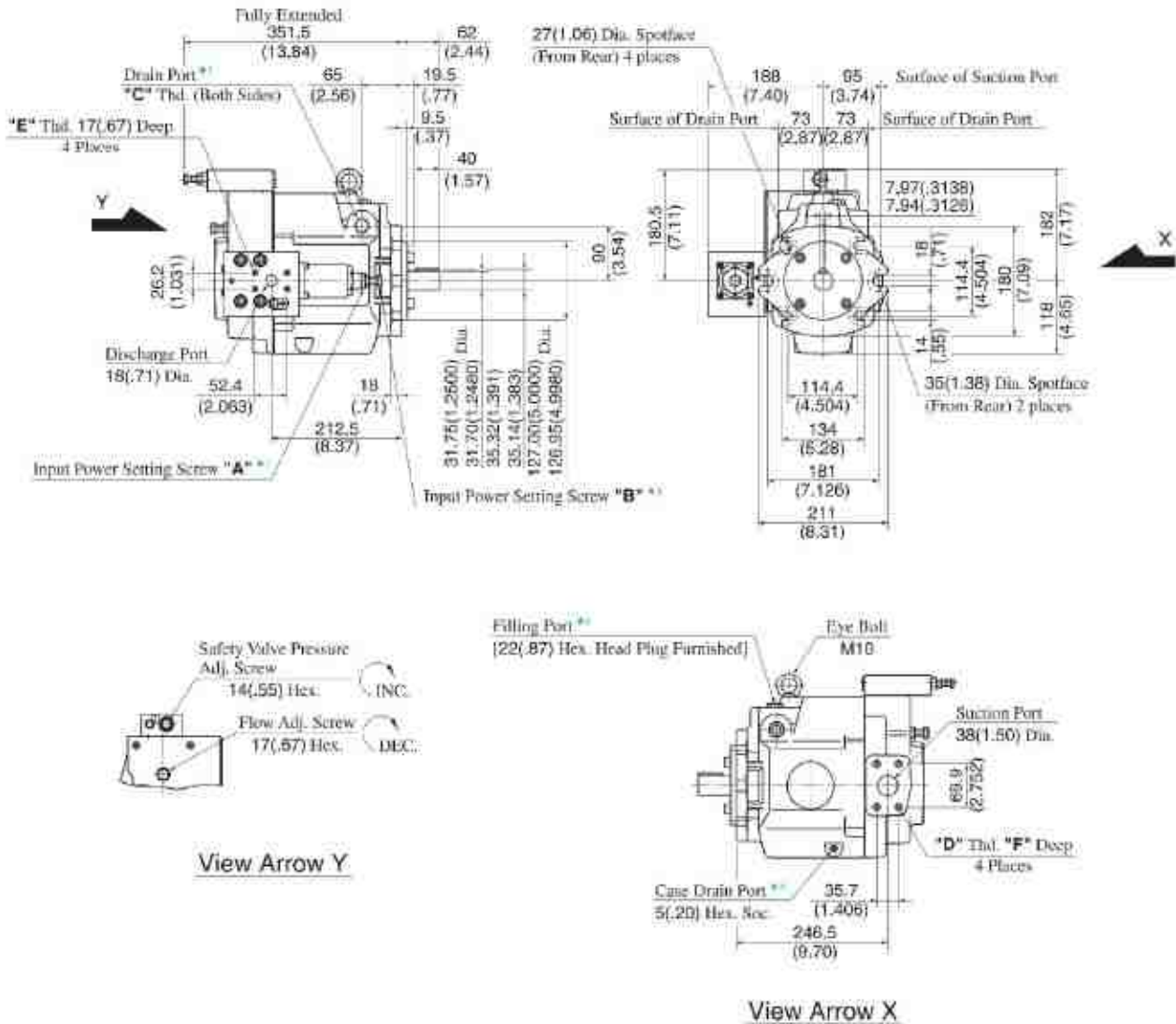

- ★ 1. Install the pump so that the "Filling Port" is at the top.
- ★ 2. Use either port of two drain ports at your option. Keep the remaining port plugged.
- ★ 3. Do not touch the screw because it is adjusted at the time of shipment.
- ★ 4. Case drain port is available for use when draining hydraulic fluid from pump casing.

Model Numbers	*C* Thd.	*D* Thd.	*E* Thd.	F mm (IN.)
A70-FR09*S-60	Rc 3/4			
A70-FR09*S-6080	3/4 BSP.F	M12	M10	19 (.75)
A70-FR09*S-60950	SAE #12	1/2-13 UNC	3/8-16 UNC	21 (.83)

DIMENSIONS IN MILLIMETRES (INCHES)

● **Foot Mounting Type**

Mounting bracket is common to that of pressure compensator model. Refer to page 48 for the dimensions of mounting bracket.

Flange Mfg. : A145-FR09#S-60/6080/60950

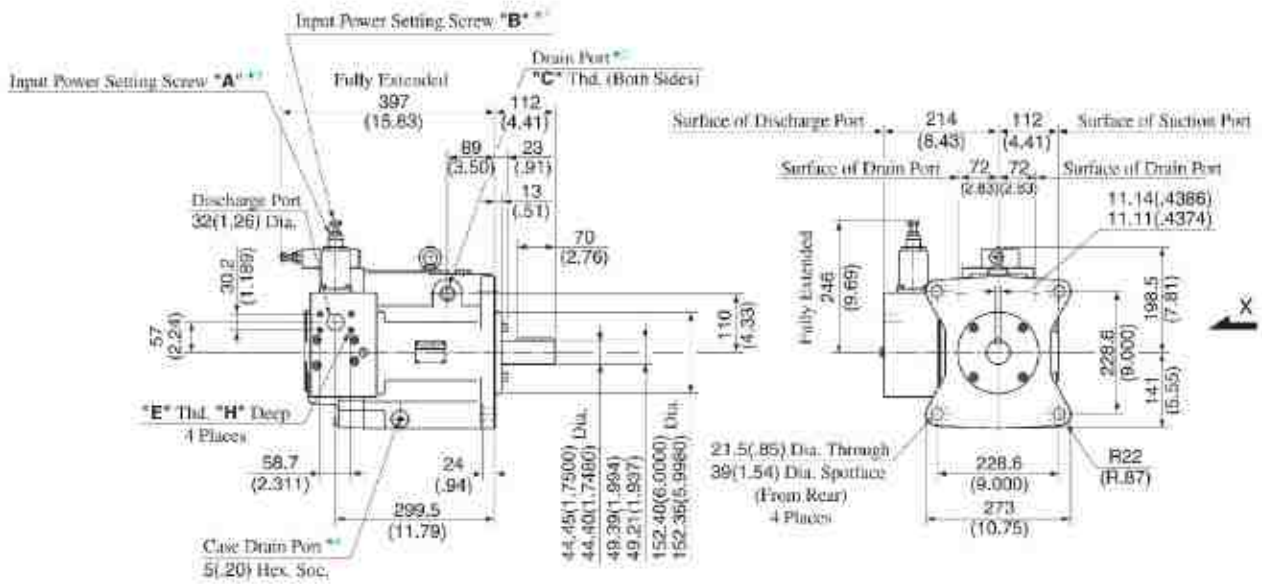

- ★ 1 Install the pump so that the "Filling Port" is at the top.
- ★ 2 Use either port of two drain ports at your option. Keep the remaining port plugged.
- ★ 3 Do not touch the screw because it is adjusted at the time of shipment.
- ★ 4 Case drain port is available for use when draining hydraulic fluid from pump casing.

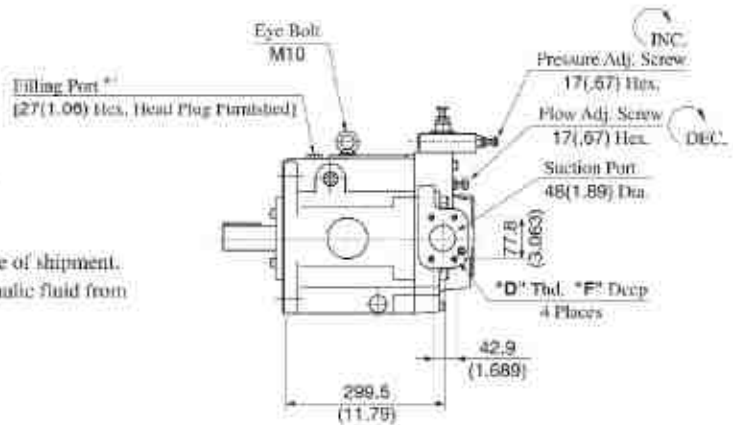

View Arrow X

Model Numbers	"C" Thd.	"D" Thd.	"E" Thd.	F mm (IN.)	H mm (IN.)
A145-FR09#S-60	Re 3/4	M12	M10	19 (.75)	19 (.75)
A145-FR09#S-6080	3/4 BSP.F				
A145-FR09#S-60950	SAE #12	1/2-13 UNC	7/16-14 UNC	21 (.83)	20 (.79)

DIMENSIONS IN MILLIMETRES (INCHES)

● **Foot Mounting Type**

Mounting bracket is common to that of pressure compensator model.
 Refer to page 50 for the dimensions of mounting bracket.



"A" Series Variable Displacement Piston Pumps – Double Pumps, Pressure Compensator Type

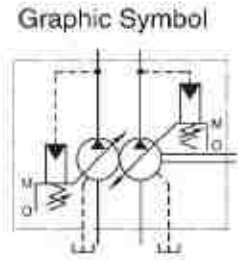

Specifications

Model Numbers		Geometric Displacement cm ³ /rev (cu.in./rev)	Min. Adj. Flow cm ³ /rev (cu.in./rev)	Operating Pressure MPa (PSI)		Shaft Speed Range r/min		Approx. Mass kg (lbs.)	
				Rated	Intermittent	Max.	Min.	Flange Mtg.	Foot Mtg.
A1616-#R01#01##K-32*	Outboard Pump	15.8 (.964)	4 (.244)	16 (2320)	21 (3050)	1800	600	35.5 (98.3)	37.7 (83.1)
	Inboard Pump	15.8 (.964)	4 (.244)	16 (2320)	21 (3050)				
A1622-#R01#01##K-32*	Outboard Pump	15.8 (.964)	4 (.244)	16 (2320)	21 (3050)	1800	600	35.5 (98.3)	37.7 (83.1)
	Inboard Pump	22.2 (1.355)	6 (.366)	16 (2320)	16 (2320)				
A2222-#R01#01##K-32*	Outboard Pump	22.2 (1.355)	6 (.366)	16 (2320)	16 (2320)	1800	600	35.5 (98.3)	37.7 (83.1)
	Inboard Pump	22.2 (1.355)	6 (.366)	16 (2320)	16 (2320)				
A1637-#R01#01##K-32*	Outboard Pump	15.8 (.964)	4 (.244)	16 (2320)	21 (3050)	1800	600	50 (110)	54.3 (120)
	Inboard Pump	36.9 (2.25)	10 (.610)	16 (2320)	21 (3050)				
A2237-#R01#01##K-32*	Outboard Pump	22.2 (1.355)	6 (.366)	16 (2320)	16 (2320)	1800	600	50 (110)	54.3 (120)
	Inboard Pump	36.9 (2.25)	10 (.610)	16 (2320)	21 (3050)				
A1656-#R01#01##K-32*	Outboard Pump	15.8 (.964)	4 (.244)	16 (2320)	21 (3050)	1800	600	54.5 (120)	58.8 (130)
	Inboard Pump	56.2 (3.43)	12 (.732)	16 (2320)	21 (3050)				
A2256-#R01#01##K-32*	Outboard Pump	22.2 (1.355)	6 (.366)	16 (2320)	16 (2320)	1800	600	54.5 (120)	58.8 (130)
	Inboard Pump	56.2 (3.43)	12 (.732)	16 (2320)	21 (3050)				
A1670-#R01#01##-60#	Outboard Pump	15.8 (.964)	4 (.244)	16 (2320)	21 (3050)	1800	600	77.5 (171)	89.5 (197)
	Inboard Pump	70.0 (4.27)	30 (1.831)	25 (3630)	28 (4060)				
A2270-#R01#01##-60#	Outboard Pump	22.2 (1.355)	6 (.366)	16 (2320)	16 (2320)	1800	600	77.5 (171)	89.5 (197)
	Inboard Pump	70.0 (4.27)	30 (1.831)	25 (3630)	28 (4060)				
A3770-#R01#01##-60#	Outboard Pump	36.9 (2.25)	10 (.610)	16 (2320)	21 (3050)	1800	600	86.5 (191)	98.5 (217)
	Inboard Pump	70.0 (4.27)	30 (1.831)	25 (3630)	28 (4060)				
A1690-#R01#01##-60#	Outboard Pump	15.8 (.964)	4 (.244)	16 (2320)	21 (3050)	1800	600	88 (194)	108.5 (239)
	Inboard Pump	91.0 (5.55)	56 (3.42)	25 (3630)	28 (4060)				
A2290-#R01#01##-60#	Outboard Pump	22.2 (1.355)	6 (.366)	16 (2320)	16 (2320)	1800	600	88 (194)	108.5 (239)
	Inboard Pump	91.0 (5.55)	56 (3.42)	25 (3630)	28 (4060)				
A3790-#R01#01##-60#	Outboard Pump	36.9 (2.25)	10 (.610)	16 (2320)	21 (3050)	1800	600	100.5 (222)	121 (267)
	Inboard Pump	91.0 (5.55)	56 (3.42)	25 (3630)	28 (4060)				
A5690-#R01#01##-60#	Outboard Pump	56.2 (3.43)	12 (.732)	16 (2320)	21 (3050)	1800	600	107.5 (237)	128 (282)
	Inboard Pump	91.0 (5.55)	56 (3.42)	25 (3630)	28 (4060)				
A16145-#R01#01##-60#	Outboard Pump	15.8 (.964)	4 (.244)	16 (2320)	21 (3050)	1800	600	109 (240)	134 (295)
	Inboard Pump	145 (8.85)	83 (5.06)	25 (3630)	28 (4060)				
A22145-#R01#01##-60#	Outboard Pump	22.2 (1.355)	6 (.366)	16 (2320)	16 (2320)	1800	600	109 (240)	134 (295)
	Inboard Pump	145 (8.85)	83 (5.06)	25 (3630)	28 (4060)				
A37145-#R01#01##-60#	Outboard Pump	36.9 (2.25)	10 (.610)	16 (2320)	21 (3050)	1800	600	121.5 (268)	146.5 (323)
	Inboard Pump	145 (8.85)	83 (5.06)	25 (3630)	28 (4060)				
A56145-#R01#01##-60#	Outboard Pump	56.2 (3.43)	12 (.732)	16 (2320)	21 (3050)	1800	600	128.5 (283)	153.5 (338)
	Inboard Pump	145 (8.85)	83 (5.06)	25 (3630)	28 (4060)				

Consult Yuken when detailed material such as dimensions figures is required.

■ Model Number Designation

A1637	-F	R	Outboard Pump		Inboard Pump (Driven End)		S	K	-32	*					
			01	C	01	C									
Series Number	Mounting	Direction of Rotation	Control Type	Pres. Adj. Range MPa(PSI)	Control Type	Pres. Adj. Range MPa(PSI)	Port Position of Outboard Pump	Shaft Extension	Design Number	Design Std.					
A1616 (15.8/15.8 cm ³ /rev)	Viewed from Shaft End		01	B: 1.2- 7 (170-1020) C: 1.2-16 (170-2320) H: 1.2-21 (170-3050)	01	B: 1.2- 7 (170-1020) C: 1.2-16 (170-2320) H: 1.2-21 (170-3050)	S	K	32	Refer to ★1					
A1622 (15.8/22.2 cm ³ /rev)				B: 1.2- 7 (170-1020) C: 1.2-16 (170-2320)		B: 1.2- 7 (170-1020) C: 1.2-16 (170-2320)			32						
A2222 (22.2/22.2 cm ³ /rev)				B: 1.2- 7 (170-1020) C: 1.2-16 (170-2320)		B: 1.2- 7 (170-1020) C: 1.2-16 (170-2320)			32						
A1637 (15.8/36.9 cm ³ /rev)				B: 1.2- 7 (170-1020) C: 1.2-16 (170-2320) H: 1.2-21 (170-3050)		B: 1.2- 7 (170-1020) C: 1.2-16 (170-2320)			K: Keyed Shaft		32				
A2237 (22.2/36.9 cm ³ /rev)				B: 1.2- 7 (170-1020) C: 1.2-16 (170-2320)							32				
A1656 (15.8/56.2 cm ³ /rev)				B: 1.2- 7 (170-1020) C: 1.2-16 (170-2320) H: 1.2-21 (170-3050)		B: 1.2- 7 (170-1020) C: 1.2-16 (170-2320) H: 1.2-21 (170-3050)			S: Side Port		32				
A2256 (22.2/56.2 cm ³ /rev)				B: 1.2- 7 (170-1020) C: 1.2-16 (170-2320)		B: 1.2- 7 (170-1020) C: 1.2-16 (170-2320)					32				
A1670 (15.8/70.0 cm ³ /rev)				F: Flange Mtg.		R: Clockwise (Normal)			01: Pressure Compensator Type		B: 1.2- 7 (170-1020) C: 1.2-16 (170-2320) H: 1.2-21 (170-3050)	01: Pressure Compensator Type	None: Axial Port	None: Keyed Shaft	60
A2270 (22.2/70.0 cm ³ /rev)				B: 1.2- 7 (170-1020) C: 1.2-16 (170-2320)							B: 1.2- 7 (170-1020) C: 1.2-16 (170-2320)				60
A3770 (36.9/70.0 cm ³ /rev)				L: Foot Mtg.							B: 1.2- 7 (170-1020) C: 1.2-16 (170-2320) H: 1.2-21 (170-3050)				B: 1.2- 7 (170-1020) C: 1.2-16 (170-2320) H: 1.2-21 (170-3050)
A1690 (15.8/91.0 cm ³ /rev)	B: 1.2- 7 (170-1020) C: 1.2-16 (170-2320) H: 1.2-21 (170-3050)	B: 1.2- 7 (170-1020) C: 1.2-16 (170-2320) H: 1.2-21 (170-3050)	60												
A2290 (22.2/91.0 cm ³ /rev)	B: 1.2- 7 (170-1020) C: 1.2-16 (170-2320)	B: 1.2- 7 (170-1020) C: 1.2-16 (170-2320)	60												
A3790 (36.9/91.0 cm ³ /rev)	B: 1.2- 7 (170-1020) C: 1.2-16 (170-2320) H: 1.2-21 (170-3050)	B: 1.2- 7 (170-1020) C: 1.2-16 (170-2320) H: 1.2-21 (170-3050)	60												
A5690 (56.2/91.0 cm ³ /rev)	B: 1.2- 7 (170-1020) C: 1.2-16 (170-2320) H: 1.2-21 (170-3050)	B: 1.2- 7 (170-1020) C: 1.2-16 (170-2320) H: 1.2-21 (170-3050)	60												
A16145 (15.8/145 cm ³ /rev)	B: 1.2- 7 (170-1020) C: 1.2-16 (170-2320)	B: 1.2- 7 (170-1020) C: 1.2-16 (170-2320)	60												
A22145 (22.2/145 cm ³ /rev)	B: 1.2- 7 (170-1020) C: 1.2-16 (170-2320)	B: 1.2- 7 (170-1020) C: 1.2-16 (170-2320)	60												
A37145 (36.9/145 cm ³ /rev)	B: 1.2- 7 (170-1020) C: 1.2-16 (170-2320) H: 1.2-21 (170-3050)	B: 1.2- 7 (170-1020) C: 1.2-16 (170-2320) H: 1.2-21 (170-3050)	60												
A56145 (56.2/145 cm ³ /rev)	B: 1.2- 7 (170-1020) C: 1.2-16 (170-2320) H: 1.2-21 (170-3050)	B: 1.2- 7 (170-1020) C: 1.2-16 (170-2320) H: 1.2-21 (170-3050)	60												

★1. Available to supply pump with anti-clockwise rotation. Consult Yuken for details.

★2. Design Standards: None..... Japanese Standard "JIS"
80..... European Design Standard
950..... N. American Design Standard



"A" Series Piston Pumps – Variable / Fixed Double Pumps



Graphic Symbol

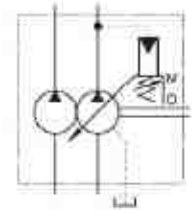

Model Number Designation

A16R1	-F	R	Inboard Pump (Driven End)		Outboard Pump			K	-32	*
			01	B	-23	A	A			
Series Number	Mounting	Direction of Rotation	Control Type	Pres. Adj. Range MPa(PSI)	Nominal Displacement cm ³ /rev	Discharge Port Position	Suction Port Position	Shaft Extension	Design Number	Design Std.
A16R1	F: Flange Mtg. L: Foot Mtg.	Viewed from Shaft End R: *1 Clockwise (Normal)	01: Pressure Compensator Type	B: 1.2 - 7 (170 - 1020) C: 1.2 - 16 (170 - 2320) H: 1.2 - 21 (170 - 3050)	6, 8 10, 12 14, 17 19, 23 25, 31	A: Up	A: Up	K: Keyed Shaft	32	Refer to *2
A22R1				B: 1.2 - 7 (170 - 1020) C: 1.2 - 16 (170 - 2320)					32	
A37R1				B: 1.2 - 7 (170 - 1020) C: 1.2 - 16 (170 - 2320) H: 1.2 - 21 (170 - 3050)					32	
A56R1				B: 1.2 - 7 (170 - 1020) C: 1.2 - 16 (170 - 2320) H: 1.2 - 21 (170 - 3050)					32	
A70R1				B: 1.2 - 7 (170 - 1020) C: 1.5 - 16 (220 - 2320) H: 1.8 - 21 (260 - 3050) K: 2.0 - 28 (290 - 4060)					60	
A90R1				B: 1.2 - 7 (170 - 1020) C: 1.5 - 16 (220 - 2320) H: 1.8 - 21 (260 - 3050) K: 2.0 - 28 (290 - 4060)					60	
A145R1				B: 1.2 - 7 (170 - 1020) C: 1.5 - 16 (220 - 2320) H: 1.8 - 21 (260 - 3050) K: 2.0 - 28 (290 - 4060)					60	
A70R2				B: 1.2 - 7 (170 - 1020) C: 1.5 - 16 (220 - 2320) H: 1.8 - 21 (260 - 3050) K: 2.0 - 28 (290 - 4060)					60	
A90R2				B: 1.2 - 7 (170 - 1020) C: 1.5 - 16 (220 - 2320) H: 1.8 - 21 (260 - 3050) K: 2.0 - 28 (290 - 4060)					60	
A145R2				B: 1.2 - 7 (170 - 1020) C: 1.5 - 16 (220 - 2320) H: 1.8 - 21 (260 - 3050) K: 2.0 - 28 (290 - 4060)					60	

*1. Available to supply pump with anti-clockwise rotation. Consult Yuken for details.

*2. Design Standards: None Japanese Standard "JIS"
80 European Design Standard
950 N. American Design Standard

Consult Yuken when detailed material such as dimensions figures is required.

Specifications

Model Numbers	Geometric Displacement cm ³ /rev (cu.in./rev)	Operating Pressure MPa (PSI)		Shaft Speed Range r/min		Approx. Mass kg (lbs.)	
		Rated	Intermittent	Max.	Min.	Flange Mtg.	Foot Mtg.
A16R1-#R01#-#AAK-32*	Outboard Pump	Refer to the following table		1800	750	28.8 (63.5)	31.0 (68.4)
	Inboard Pump	15.8 (.964)	16 (2320)				
A22R1-#R01#-#AAK-52*	Outboard Pump	Refer to the following table		1800	750	28.8 (63.5)	31.0 (68.4)
	Inboard Pump	22.2 (1.355)	16 (2320)				
A37R1-#R01#-#AAK-32*	Outboard Pump	Refer to the following table		1800	750	39 (86.0)	43.3 (95.5)
	Inboard Pump	36.9 (2.25)	16 (2320)				
A56R1-#R01#-#AAK-32*	Outboard Pump	Refer to the following table		1800	750	47 (104)	51.3 (113)
	Inboard Pump	56.2 (3.43)	16 (2320)				
A70R1-#R01#-#AA-60*	Outboard Pump	Refer to the following table		1800	750	66 (146)	78 (172)
	Inboard Pump	70.0 (4.27)	25 (3630)				
A90R1-#R01#-#AA-60*	Outboard Pump	Refer to the following table		1800	750	82 (181)	105 (232)
	Inboard Pump	91.0 (5.55)	25 (3630)				
A145R1-#R01#-#AA-60*	Outboard Pump	Refer to the following table		1800	750	102 (225)	129 (284)
	Inboard Pump	145 (8.85)	25 (3630)				
A70R2-#R01#-#AA-60*	Outboard Pump	Refer to the following table		1800	600	72.5 (160)	84.5 (186)
	Inboard Pump	70.0 (4.27)	25 (3630)				
A90R2-#R01#-#AA-60*	Outboard Pump	Refer to the following table		1800	600	91.5 (202)	112 (247)
	Inboard Pump	91.0 (5.55)	25 (3630)				
A145R2-#R01#-#AA-60*	Outboard Pump	Refer to the following table		1800	600	112 (247)	137 (302)
	Inboard Pump	145 (8.85)	25 (3630)				

Geometric Displacement and Max. Pressure of Outboard Pump

Model Numbers	Geometric Displacement cm ³ /rev (cu.in./rev)	Max Pres. MPa (PSI)	
		Anti-Wear Type	R & O Type
A#R1-#R01#-6	5.8 (.354)	21 (3050)	16 (2320)
A#R1-#R01#-8	8.0 (.488)		
A#R1-#R01#-10	9.4 (.574)		
A#R1-#R01#-12	12.2 (.744)	21 (3050)	16 (2320)
A#R1-#R01#-14	13.7 (.836)		
A#R1-#R01#-17	16.6 (1.013)		
A#R1-#R01#-19	18.6 (1.135)		
A#R1-#R01#-23	22.7 (1.385)		
A#R1-#R01#-25	25.3 (1.544)	15 (2180)	15 (2180)
A#R1-#R01#-31	31.0 (1.892)	12 (1740)	12 (1740)
A#R2-#R01#-20	26.0 (1.623)	21 (3050)	14 (2030)
A#R2-#R01#-33	33.3 (2.03)		
A#R2-#R01#-41	41.3 (2.52)		
A#R2-#R01#-47	47.2 (2.88)		
A#R2-#R01#-53	52.5 (3.20)		
A#R2-#R01#-59	58.2 (3.55)		
A#R2-#R01#-65	64.7 (3.95)		