

"A3H" Series Variable Displacement Piston Pumps

www.khadimhydraulic.com
 Tell: 021-55882749
 Tell: 021-33488178
 Fax: 021-33488105



Pressure Compensator Type



Constant Power (Torque)
Control Type



Load Sensing Type

"A3H" Series Variable Displacement Piston Pumps

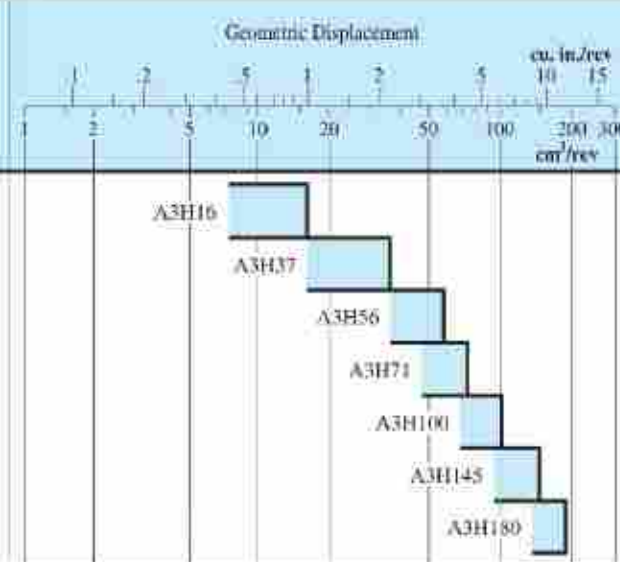
Pump Type	Graphic Symbol	Geometric Displacement		Maximum Operating Pressure: MPa (PSI)	Page
		cm ³ /rev	cu. in./rev		
Single Pump				35 (5080)	120
		A3H16			
		A3H37			
		A3H56			
		A3H71			
		A3H100			
		A3H145			
A3H180					

• Three control types are available such as pressure compensator type. Refer to page 121.

Hydraulic Fluids

Hydraulic Fluids

Use petroleum base oils such as anti-wear type hydraulic oils or R & O (Rust and Oxidation inhibitor) type hydraulic oils equivalent to ISO VG-32 or 46.

The recommended viscosity range is from 20 to 400 mm²/s (98 to 1800 SSU) and temperature range is from 0 to 60°C (32 to 140°F), both of which have to be satisfied for the use of the above hydraulic oils.

Control of Contamination

Due caution must be paid to maintaining control over contamination of the operating oil which can otherwise lead to breakdowns and shorten the life of the unit. Please maintain the degree of contamination within NAS Grade 10.

The suction port must be equipped with at least a 100 µm (150 mesh) reservoir type filter and the return line must have a line filter of under 10 µm.

Instructions

Mounting

When installing the pump the filling port should be positioned upwards.

Alignment of Shaft

Employ a flexible coupling whenever possible, and avoid any stress from bending or thrust.

Maximum permissible misalignment is less than 0.1 mm (.0039 inches) TIR and maximum permissible misangular is less than 0.2°.

Suction Pressure

Permissible suction pressure at suction port of the pump is between -16.7 and +50 kPa (5 in.Hg Vacuum and 7 PSIG). In case of the speed is over 1800 r/min, adjust the pressure 0 to +50 kPa (0 to 7 PSIG).

For piping to the suction port, use the pipes of the same diameter as that of the specified pipe flange to be used.

Make sure that the height of the pump suction port is within one metre (3.3ft.) from the oil level in the reservoir.

Hints on Piping

When using steel pipes for the suction or discharge ports, excessive load from the piping to the pump generates excessive noise.

Whenever there is fear of excessive load, please use rubber hoses.

Suction Piping

In case the pump is installed above the oil level, the suction piping and suction line filter should be located lower than the pump position to prevent air in the suction line.

Drain Piping

Install drain piping according to the chart and ensure that pressure within the pump housing should be maintained at a normal pressure of less than 0.1 MPa (15 PSI) and surge pressure of less than 0.5 MPa (70 PSI).

Length of piping should be less than 1 m (3.3 ft.), and the pipe end should be submerged in oil.

[Recommended Drain Piping Size]

Model	Fitting Size		Inside Dia. of Pipe
	Japanese Std. "JIS" & European Design Std.	N.American Design Std.	
A3H16 A3H37	1/2 [Inside Dia. 12 mm (.47 in.) or more]	SAE #10	12 mm (.47 in.) or more
A3H56 A3H180	3/4 [Inside Dia. 16 mm (.63 in.) or more]	SAE #12	19 mm (.75 in.) or more

Safety Valve

When delivery line is blocked suddenly, surge pressure is occurred so a safety valve should be set in the circuit to eliminate any damage on equipment and piping.

Bleeding Air

It may be necessary to bleed air from pump case and outlet line to remove causes of vibration.

Starting

Before first starting, fill pump case with clean operating oil via the fill port.

In order to avoid air blockage when first starting, adjust the control valves so that the discharged oil from the pump is returned direct to the tank or the actuator moves in a free load.

[Volume of Pre-fill Oil Required]

Model	Volume cm ³ (in. ³)
A3H16	400 (24.4)
A3H37	700 (42.7)
A3H56	900 (54.9)
A3H71	1300 (79.3)
A3H100	1700 (104)
A3H145	2400 (146)
A3H180	3200 (195)



Setting Discharge Pressure and Delivery

At the time of shipment, the unit has been preset to maximum delivery and minimum discharge pressure. Adjust the preset delivery and pressure to meet your system requirements.

Adjustment of Discharge Pressure

Turning the adjustment screw clockwise, increases pressure.

[Volume adjusted by each full turn of the pressure adjustment screw]

Model Numbers	Adjustment Volume MPa (PSI)
A3H16/A3H37/A3H56-01	5.5 (780)
A3H71/A3H100/A3H145-01	6.3 (915)
A3H180-01	5.7 (830)

Adjustment of Delivery

Turning the flow adjustment screw clockwise, decreases delivery.

[The minimum adjustable flow and adjustable volume of each full turn of the delivery adjustment screw]

Model Numbers	Adjustable volume with each full turn of the adjustment screw cm ³ /rev (cu.in./rev)	Minimum adjustment flow cm ³ /rev (cu.in./rev)
A3H16	1.4 (.085)	8 (.488)
A3H37	3.3 (.201)	16 (.976)
A3H56	4.2 (.256)	35 (2.14)
A3H71	4.9 (.299)	45 (2.75)
A3H100	6.2 (.378)	63 (3.84)
A3H145	9.4 (.574)	95 (5.80)
A3H180	10.3 (.629)	125 (7.63)

Flow Adjustment Screw Protrusion Length "L" vs. Geometric Displacement (reference)

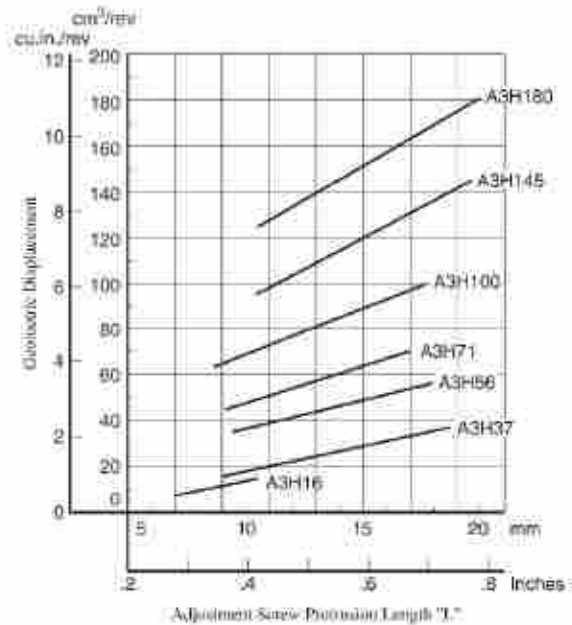
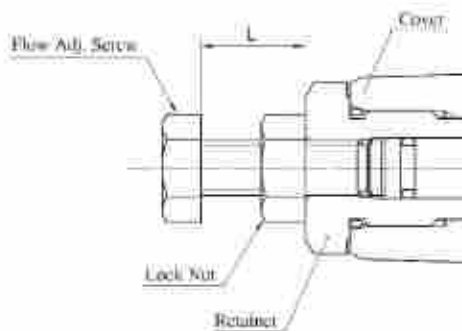

"A3H" Series Variable Displacement Piston Pumps

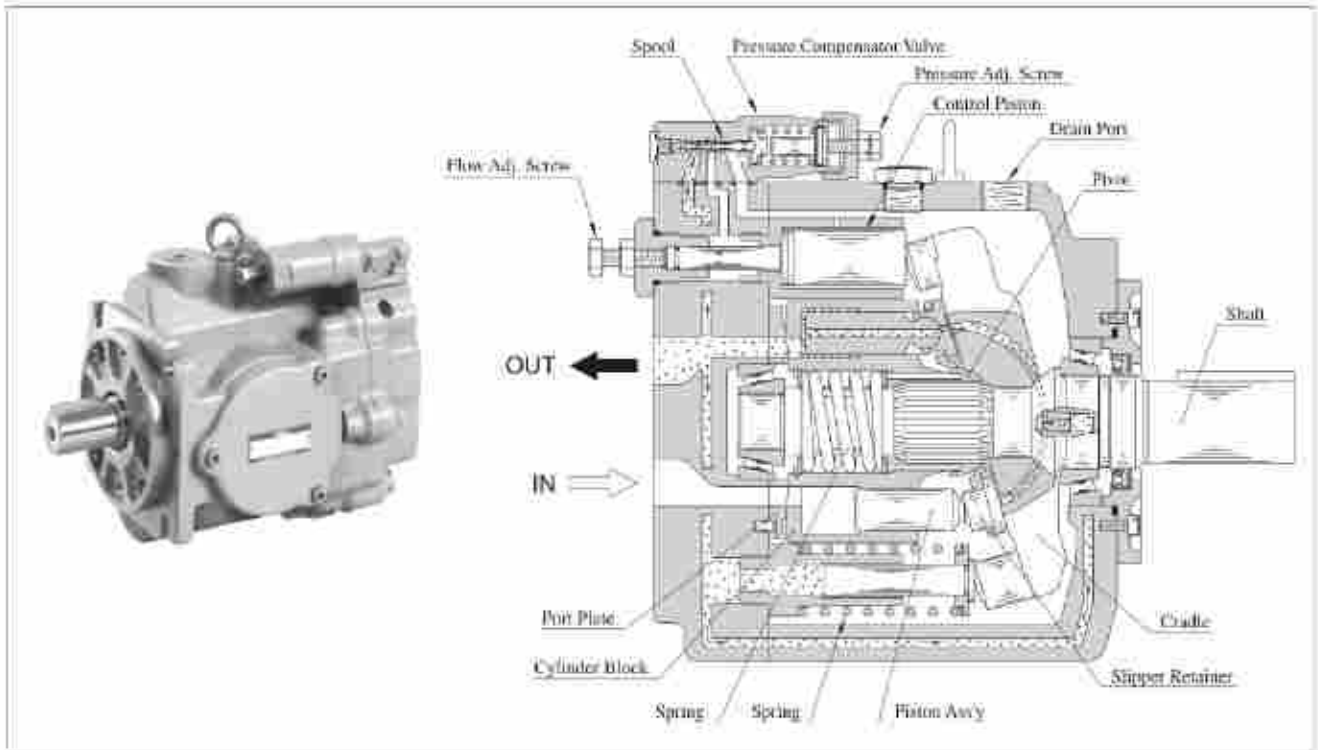

Control Type

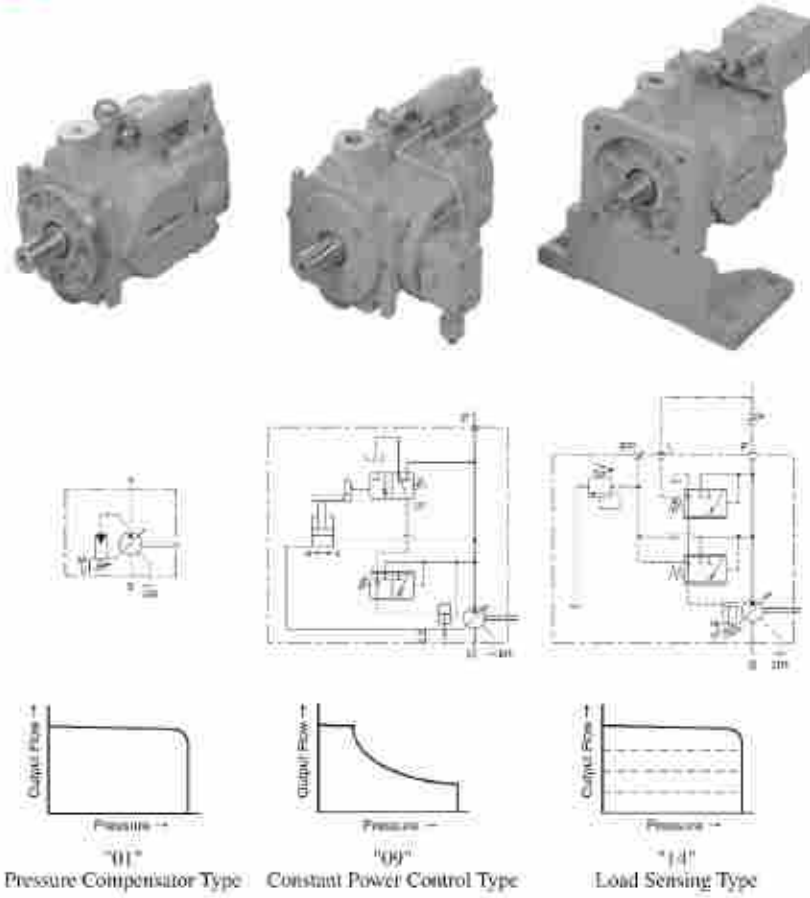

Features

- High performance at maximum pressure 35MPa

Volumetric efficiency is over 95% and overall efficiency is more than 90% at 1800 r/min.

"A3H37" type performance characteristics

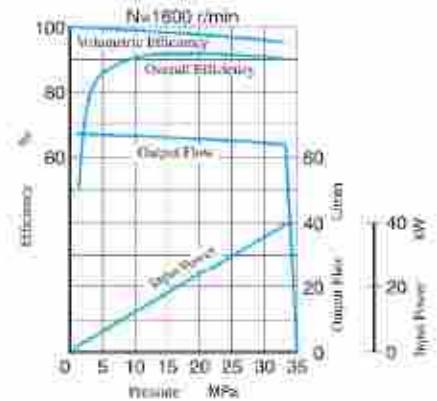





- Compact size

A3H series are compact in size because output / mass ratio is large.

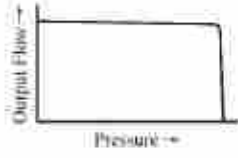

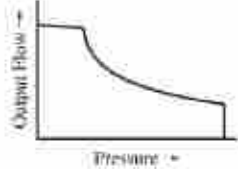
Control Type

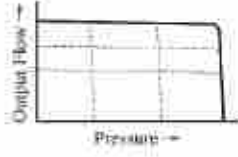
Control Type	Graphic Symbols	Performance Characteristics	Explanation	Page
"01" Pressure Compensator Type			When the system pressure increases and comes close to the preset cut-off pressure, the pump flow decreases automatically while maintaining the set pressure as it is.	122
"09" Constant Power (Torque) Control Type			<ul style="list-style-type: none"> This type of control can control the pump input power according to the motor output. When the system pressure increases, the pump swash plate tilt angle (output flow) decreases, in correspondence to predetermined shaft input values. This type of control can enable one pump to act as two pumps (low-pressure and large-flow/high-pressure and small-flow). Therefore, the motor capacity can be reduced. 	141
"14" Load Sensing Type			<ul style="list-style-type: none"> This is an energy-saving type control which maintains the pump flow and load pressure at the absolute minimum necessary level to operate the actuator. This type of control automatically regulates the output flow so that the inlet-outlet differential pressure of the flow control valve at the output side is constant. To do so, the load pressure must be introduced to the load sensing port "L" of the pump through the external piping. This type of control provides the remote control of the full cut-off pressure by connecting a remote control relief valve to the pilot port "PP". 	150

* A flow control valve is not included with the pump. Install the valve separately.

Availability of Control Type

Mark "○" in the table below refers to standard model.

Model Numbers	Geometric Displacement, cm ³ /rev (cu. in./rev)	"01" Pressure Compensator Type	"09" Constant Power (Torque) Control Type	"14" Load Sensing Type
A3H 16	16.3 (995)	○		○
A3H 37	37.1 (2.26)	○	○	○
A3H 56	56.3 (3.44)	○	○	○
A3H 71	70.7 (4.31)	○	○	○
A3H100	100.5 (6.13)	○	○	○
A3H145	145.2 (8.86)	○	○	○
A3H180	180.7 (11.03)	○	○	○

"A3H" Series Variable Displacement Piston Pumps-Single Pump, Pressure Compensator Type



Graphic Symbol

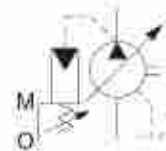

Specifications

Model Number	Geometric Displacement cm ³ /rev (cu.in./rev)	Minimum Adj. Flow cm ³ /rev (cu.in./rev)	Operating Pressure MPa (PSI)		Shaft Speed Range r/min		Approx. Mass kg (lbs.)	
			Rated ^{*1}	Intermittent	Max. ^{*2}	Min.	Flange Mtg.	Foot Mtg.
A3H 16-#R01KK-10*	16.3 (1.995)	8.0 (.488)	28 (4060)	35 (5080)	3600	600	14.5 (32.0)	23.4 (51.6)
A3H 37-#R01KK-10*	37.1 (2.26)	16.0 (.976)			2700	600	19.5 (43.0)	27.0 (59.5)
A3H 56-#R01KK-10*	56.3 (3.44)	35.0 (2.14)			2500	600	25.7 (56.7)	33.2 (73.2)
A3H 71-#R01KK-10*	70.7 (4.31)	45.0 (2.75)			2300	600	35.0 (77.2)	42.5 (93.7)
A3H100-#R01KK-10*	100.5 (6.13)	63.0 (3.84)			2100	600	44.6 (98.3)	72.6 (160)
A3H145-#R01KK-10*	145.2 (8.86)	95.0 (5.80)			1800	600	60.0 (132)	88.0 (194)
A3H180-#R01KK-10*	180.7 (11.03)	125.0 (7.63)			1800	600	70.4 (155)	98.4 (217)

- *1. Consult Yuken when pump is used over rated pressure because there is a restriction on operating condition.
- *2. The maximum shaft speeds shown in the above table are at suction pressure 0 kPa (0 PSIG).
- *3. The table above shows specifications for using petroleum-based oils.
 Pumps (customized design) for special fluids are also available. Their operating pressure and maximum shaft speed however differ from the values in the table above depending on the fluid type.
 Range of operating temperature and viscosities may differ from those of petroleum based oils due to their characteristics.

Specifications and Design numbers for Special Fluids

Type of Fluids	Operating Pressure MPa (PSI)		Allowable Maximum Shaft Speed r/min		Temperature Range °C (°F)	Viscosity Range mm ² /s (SSU)	Design Numbers for Special Fluid (Occasion of Japanese Std. "JIS") *
	Rated	Intermittent	Rated	Max.			
Water-Glycols	21 (3050)	21 (3050)	1200	(1800) ^{*1}	0 - 50 (32 - 104)	20 - 200 (98 - 927)	1030
Phosphate Ester Type	21 (3050)	21 (3050)	1200	(1800) ^{*1}	0 - 60 (32 - 140)		1006
Polyol Ester Type	21 (3050)	25 (3630)	1200	1800	0 - 60 (32 - 140)	20 - 200 (98 - 927)	10450

- *1. As the specific gravities of water-glycol fluids and phosphate ester type fluids are higher than one, an overhead reservoir is required when pumps are operated at 1500 r/min or more.
- *2. For the design numbers of pumps for European Design and North American Design Standards, please contact us.

Model Number Designation

A3H16	-F	R	01	K	K	-10	*
Series Number	Mounting	Direction of Rotation	Control Type	Pres. Adj. Range MPa (PSI)	Shaft Extension **	Design Number	Design Std.
A3H16 (16.3 cm ³ /rev)	F: Flange Mtg.	Viewed from Shaft End	01: Pressure Compensator Type	K: 5 - 35 (725 - 5080)	K : Keyed Shaft	10	Refer to ★3
A3H37 (55.1 cm ³ /rev)						10	
A3H56 (56.3 cm ³ /rev)						10	
A3H71 (70.7 cm ³ /rev)	L: Foot Mtg.	R: Clockwise ** (Normal)	01: Pressure Compensator Type	K: 5 - 35 (725 - 5080)	K : Keyed Shaft	10	Refer to ★3
A3H100 (100.5 cm ³ /rev)	F: Flange Mtg.					10	
A3H145 (145.2 cm ³ /rev)	L: Foot Mtg. **					10	
A3H180 (180.7 cm ³ /rev)					K1: Keyed Shaft ** 50.8mm (2.0 IN.) Dia.	10	

- ★1. Available to supply pump with anti-clockwise rotation. Consult Yuken for details.
- ★2. We can also supply spline-type shaft extension. Consult Yuken for details.
- ★3. Design Standards: None Japanese Standard "JIS"
 80 European Design Standard
 950 N. American Design Standard (Applicable only for A3H16/37/56/71)
 951 N. American Design Standard (Applicable only for A3H100/145/180)
- ★4. Mounting type "L" is not available for N. American Design Standard.
- ★5. Shaft extension "K1" is applicable only for N. American Design Standard.

Pipe Flange Kits

Pipe flange kits are available. When ordering, specify the kit number from the table below.

Pump Model Numbers	Name of Port	Threaded Connection			Socket Welding		Butt Welding	
		Japanese Std. "JIS"	European Design Std.	N. American Design Standard	Japanese Std. "JIS" & European Design Std.	N. American Design Standard	Japanese Std. "JIS" & European Design Std.	N. American Design Standard
A3H16-#R01	Suction	F5-08-A-10	F5-08-A-1080	—	F5-08-B-10	F5-08-B-1090	F5-08-C-10	F5-08-C-1090
	Discharge	F6-06-A-M-10 ^{★1}	F6-06-A-M-1080	—	F6-06-B-M-10	F6-06-B-U-1090	—	—
A3H37-#R01	Suction	F5-10-A-10	F5-10-A-1080	—	F5-10-B-10	F5-10-B-1090	F5-10-C-10	F5-10-C-1090
	Discharge	F6-08-A-M-10 ^{★1}	F6-08-A-M-1080	—	F6-08-B-M-10	F6-08-B-U-1090	—	—
A3H56-#R01	Suction	F5-12-A-10	F5-12-A-1080	—	F5-12-B-10	F5-12-B-1090	F5-12-C-10	F5-12-C-1090
	Discharge	F6-08-A-M-10 ^{★1}	F6-08-A-M-1080	—	F6-08-B-M-10	F6-08-B-U-1090	—	—
A3H71-#R01	Suction	F5-16-A-10	F5-16-A-1080	—	F5-16-B-10	F5-16-B-1090	F5-16-C-10	F5-16-C-1090
	Discharge	F6-10-A-M-10 ^{★1}	F6-10-A-M-1080	—	F6-10-B-M-10	F6-10-B-U-1090	—	—
A3H100-#R01 A3H145-#R01	Suction	F5-20-A-10	F5-20-A-1080	—	F5-20-B-10	F5-20-B-1090	F5-20-C-10	F5-20-C-1090
	Discharge	F6-10-A-M-10 ^{★1}	F6-10-A-M-1080	—	F6-10-B-M-10	F6-10-B-U-1090	—	—
A3H180-#R01	Suction	F5-24-A-10	F5-24-A-1080	—	F5-24-B-10	F5-24-B-1090	—	—
	Discharge	F6-12-A-M-10 ^{★1}	F6-12-A-M-1080	—	F6-12-B-M-10	F6-12-B-U-1090	—	—

- ★1. These flanges are with tapered threaded port, maximum pressure is restricted at 31 MPa (4500 PSI).
- ★2. As dimensions of the surface of pipe flanges are conformed to the SAE standards mentioned below, the pipe flanges conforming to the SAE standards can be used.
 - Suction Port: SAE 4 Bolt Split Flange (Standard Pressure Series)
 - Discharge Port: SAE 4 Bolt Split Flange (High Pressure Series)
- Details of pipe flange kits are shown on page 824 & 829.

Response Characteristics Change in Accordance with Circuits and Operating Conditions.

● **Test Circuit and Conditions**

● **Circuit**

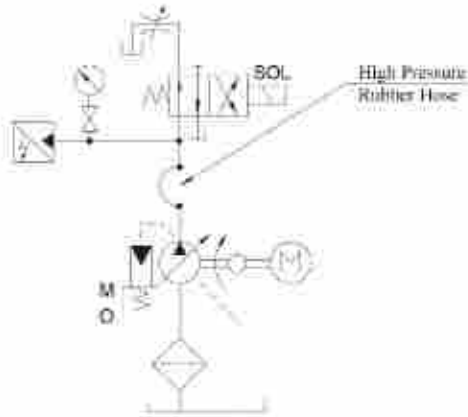

● **Conditions**

Drive Speed: 1500 r/min
 Hydraulic Fluid: ISO VG32 Oil
 Oil Temperature: 40 °C (104 °F) [Viscosity 32 mm²/s (150 SSU)]

● **Size of High Pressure Rubber Hose**

Model	High Pressure Rubber Hose
A3H16	3/4B × 1500 mm (4.9 ft.)
A3H37/56/71	3/4B × 2000 mm (6.6 ft.)
A3H100/145	1-1/4B × 2000 mm (6.6 ft.)
A3H180	1-1/4B × 2500 mm (8.2 ft.)

● **Result of Measurement**

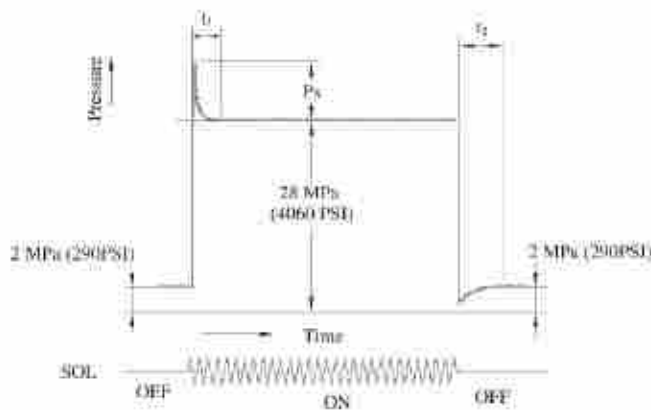

Model	Response Time (ms)		P _s Overshoot Pres. (MPa (PSI))
	t_1	t_2	
A3H 16	30	140	2.5 (363)
A3H 37	40	80	3.5 (508)
A3H 56	50	90	7.5 (1088)
A3H 71	50	140	10.0 (1450)
A3H100	70	170	11.0 (1595)
A3H145	70	180	12.5 (1813)
A3H180	70	220	12.0 (1740)



Typical Performance Characteristics of Type "A3H16" at Viscosity 32 mm²/s (150 SSU) [ISO VG32 oils, 40°C (104°F)]

Performance Characteristic Curve

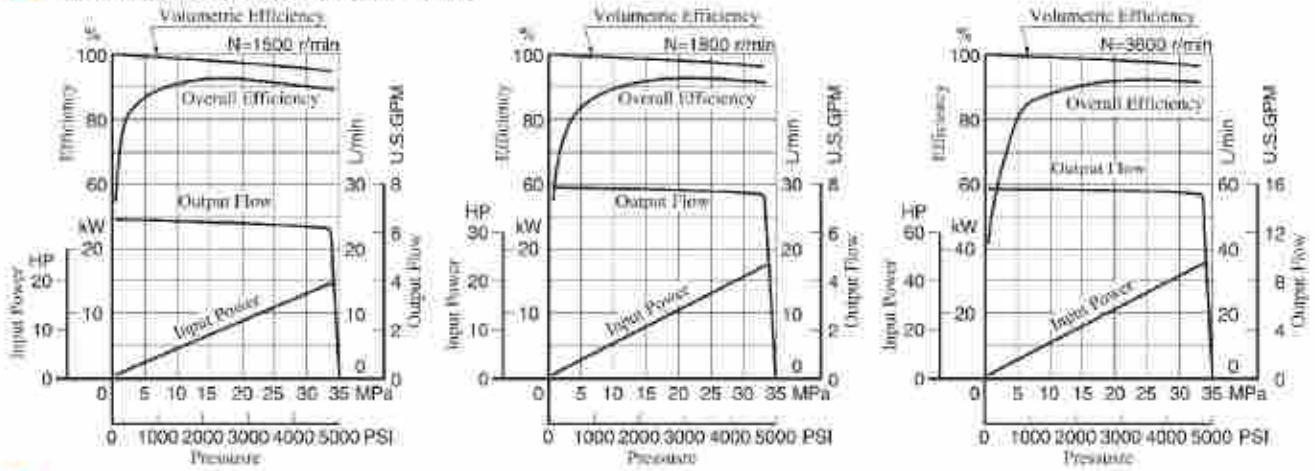

Input Power

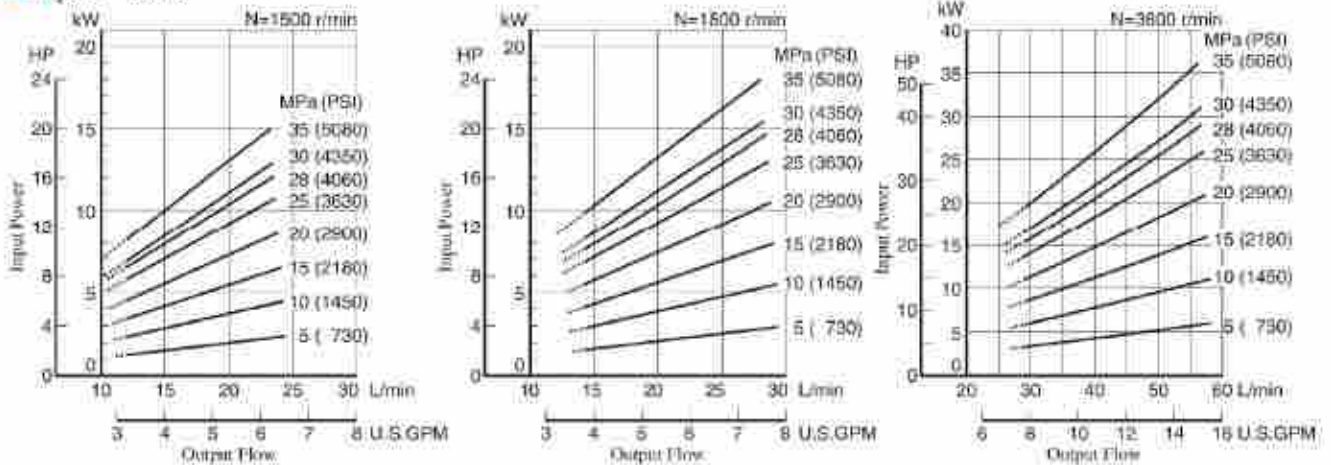

Note: The dotted line in the graph indicates less than minimum adjustable flow.

Full Cut-off Power

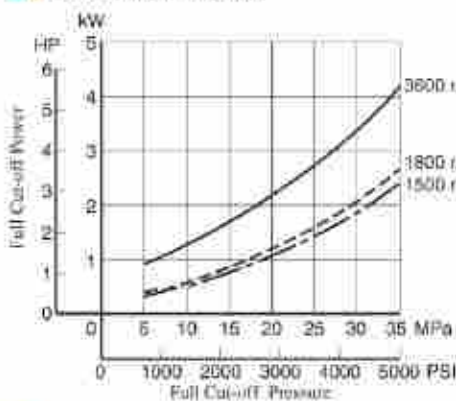

Drain

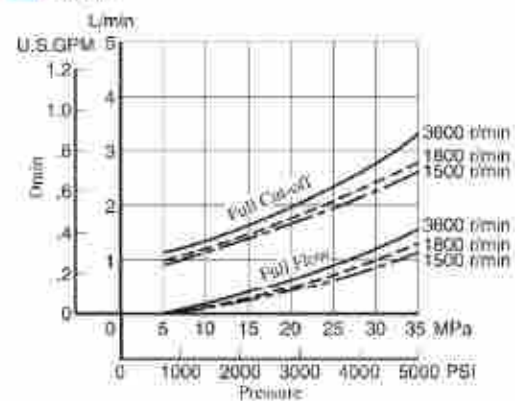

Noise Level [One metre (3.3 ft.) horizontally away from pump head cover]

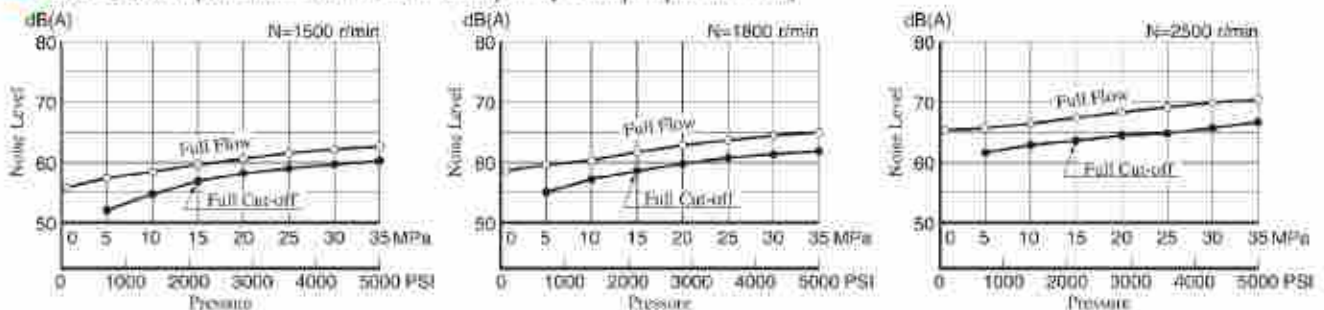

Typical Performance Characteristics of Type "A3H37" at Viscosity 32 mm²/s (150 SSU) [ISO VG32 oils, 40°C (104°F)]

Performance Characteristic Curve

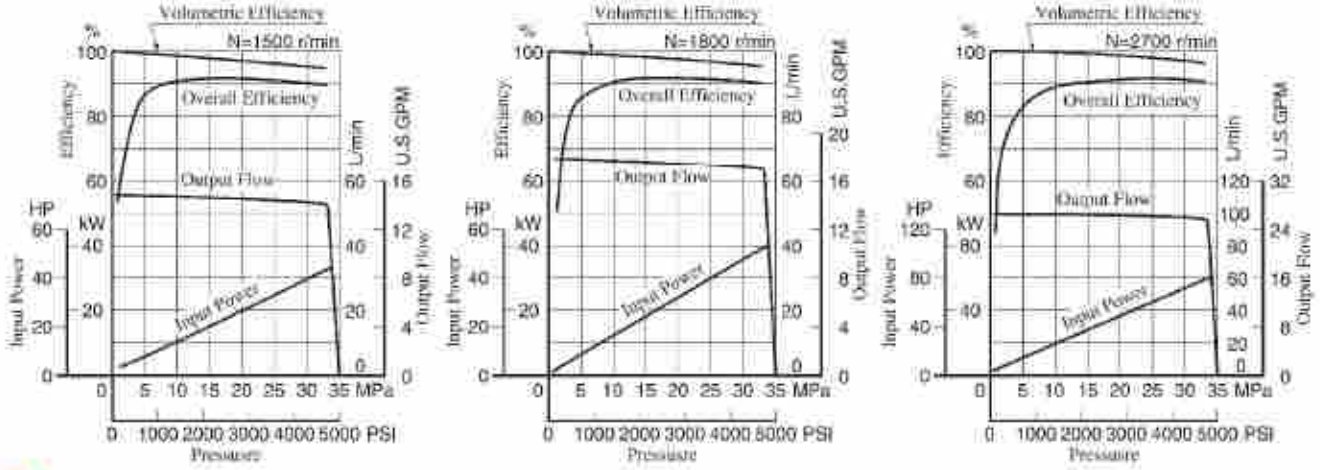

Input Power

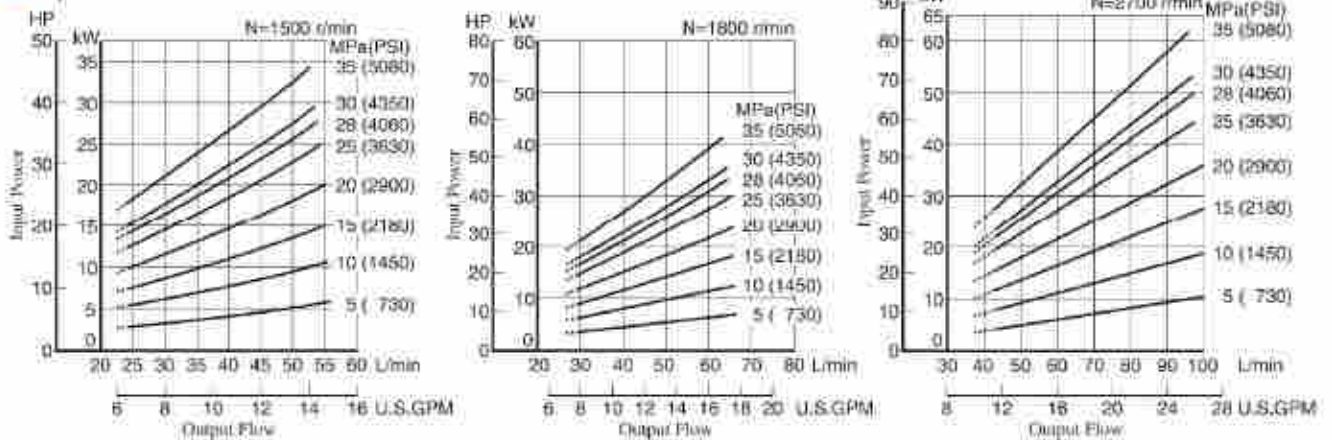

(Note) The dotted line in the graph indicates less than minimum adjustable flow.

Full Cut-off Power

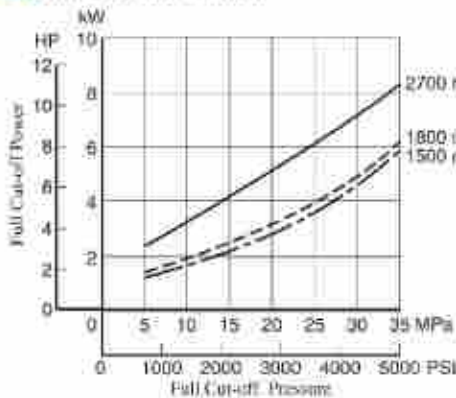

Drain

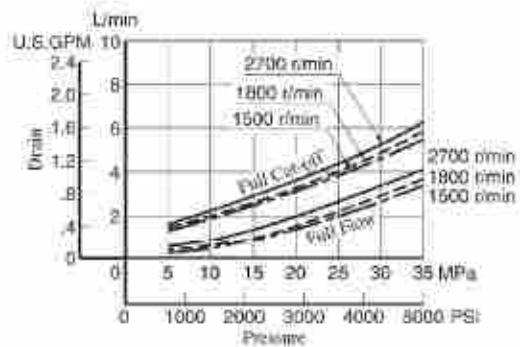

Noise Level [One metre (3.3 ft.) horizontally away from pump head cover]

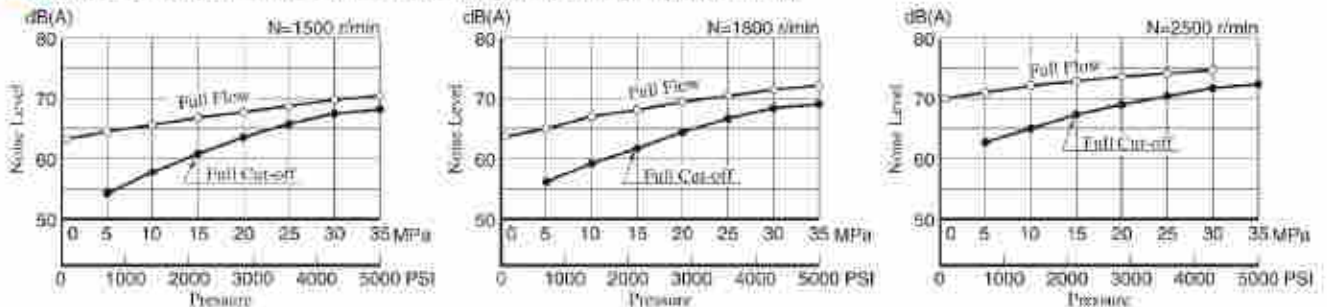

Typical Performance Characteristics of Type "A3H56" at Viscosity 32 mm²/s (150 SSU) [ISO VG32 oils, 40°C (104°F)]

Performance Characteristic Curve

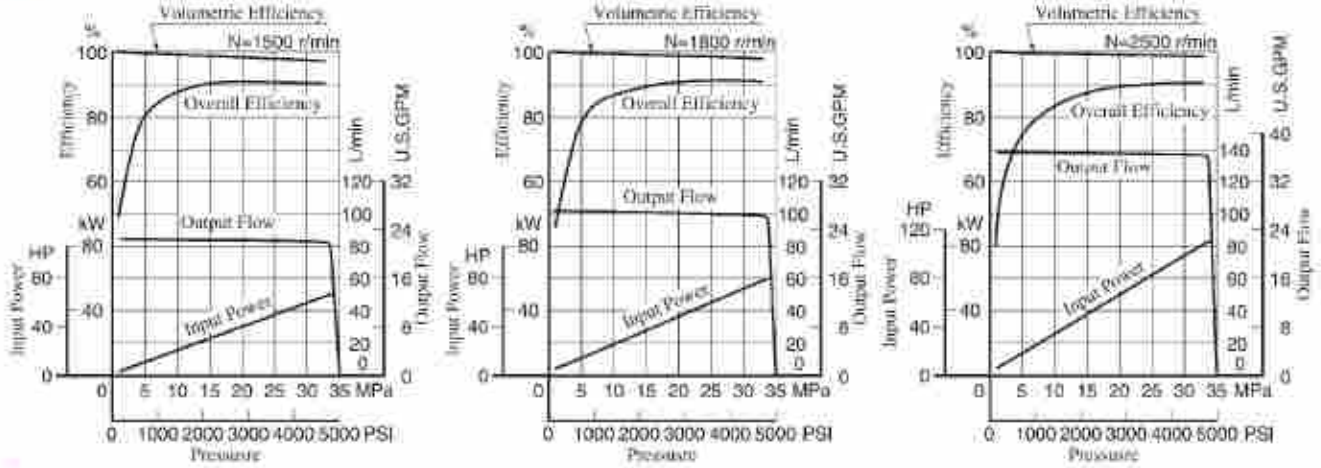

Input Power

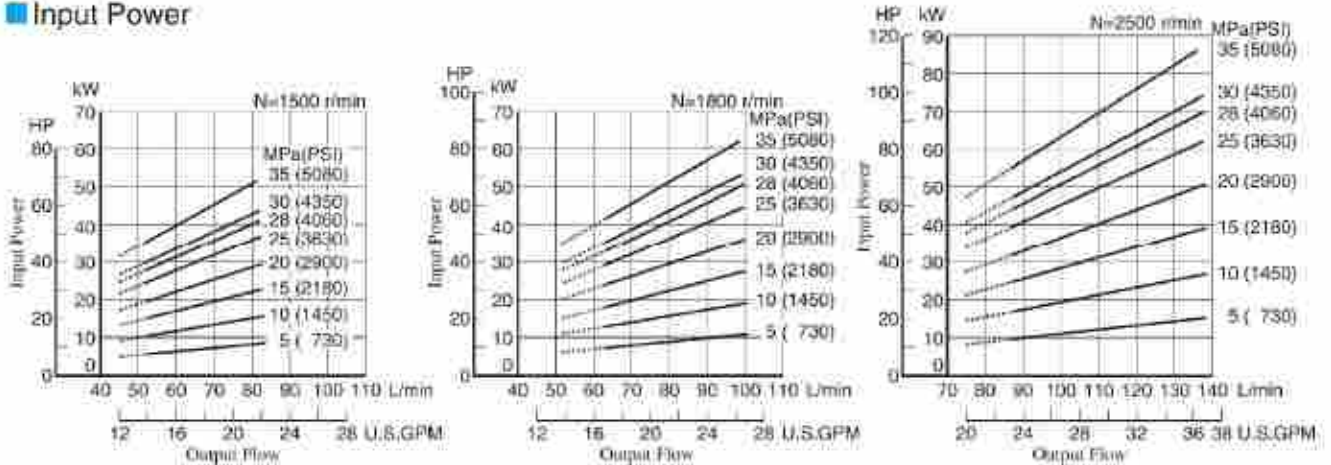

Note: The dotted line in the graph indicates less than minimum adjustable flow.

Full Cut-off Power

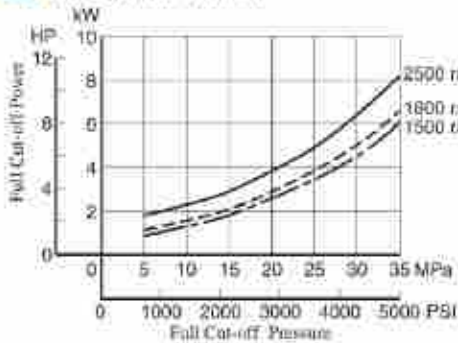

Drain

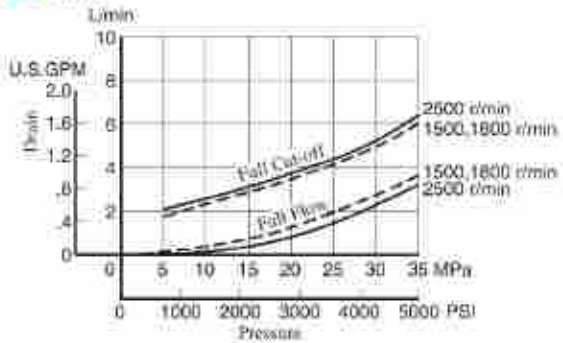

Noise Level [One metre (3.3 ft.) horizontally away from pump head cover]

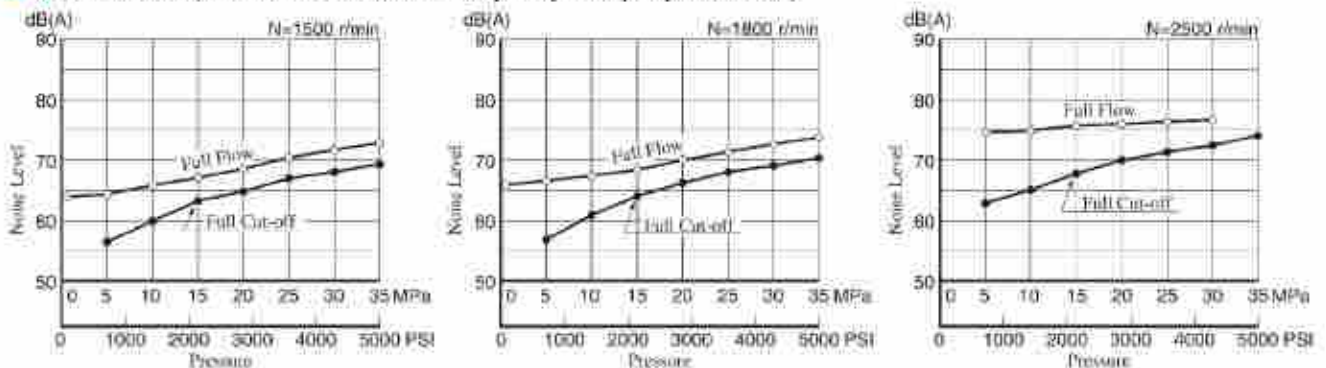

Typical Performance Characteristics of Type "A3H71" at Viscosity 32 mm²/s (150 SSU) [ISO VG32 oils, 40°C (104°F)]

Performance Characteristic Curve

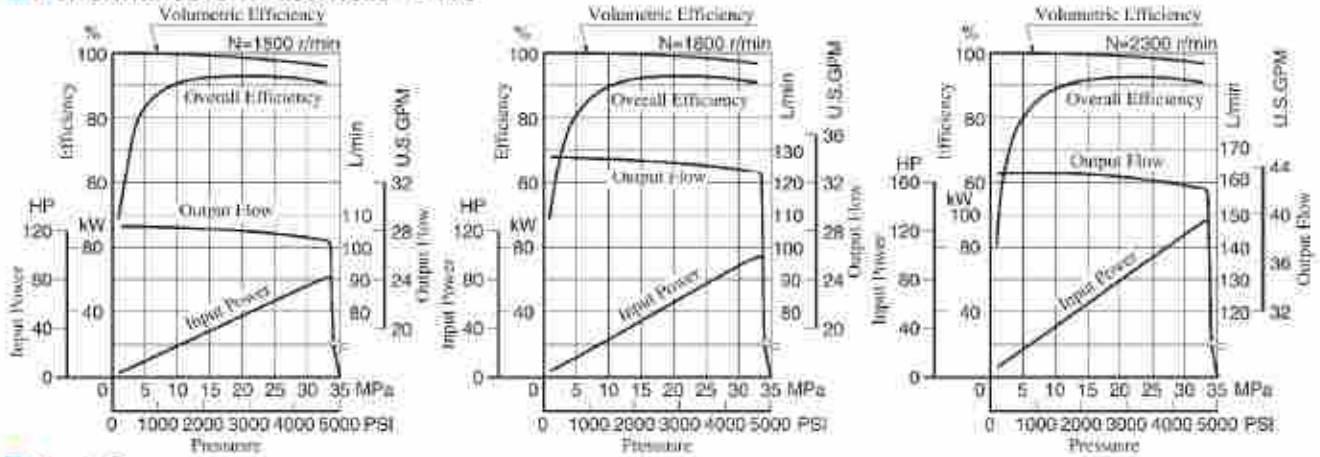

Input Power

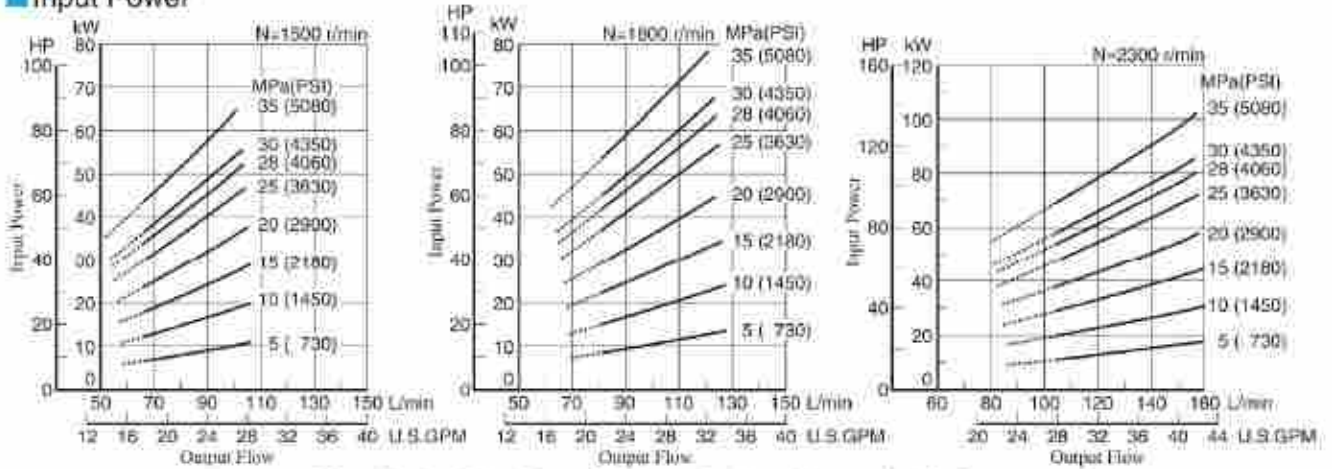

Note) The dotted line in the graph indicates less than minimum adjustable flow.

Full Cut-off Power

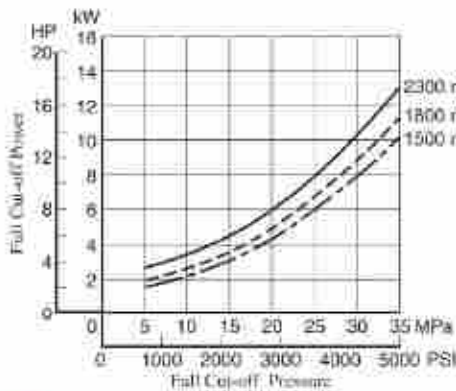

Drain

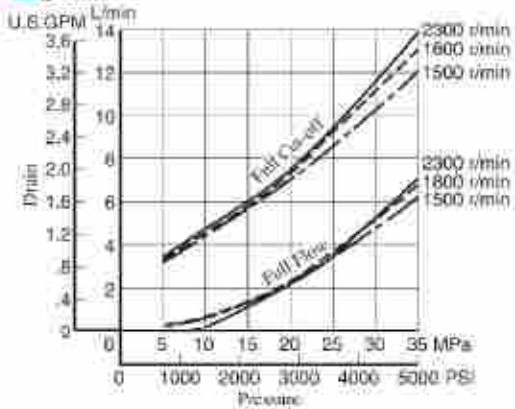

Noise Level [One metre (3.3 ft.) horizontally away from pump head cover]

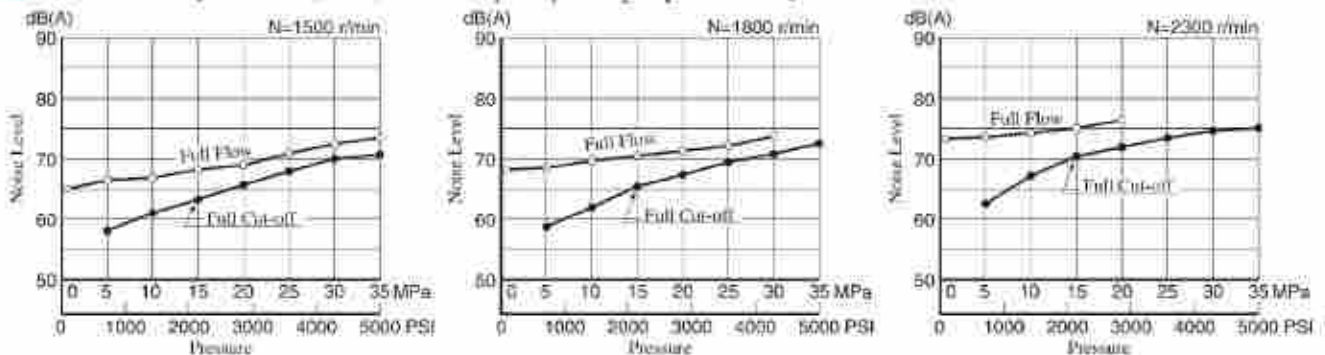

Typical Performance Characteristics of Type "A3H100" at Viscosity 32 mm²/s (150 SSU) [ISO VG32 oils, 40°C (104°F)]

Performance Characteristic Curve

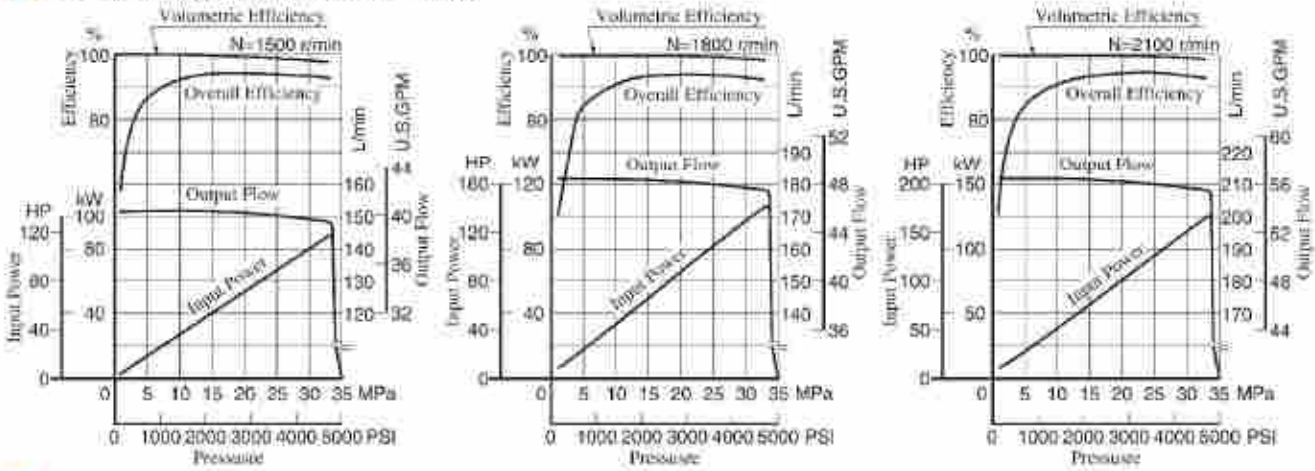

Input Power

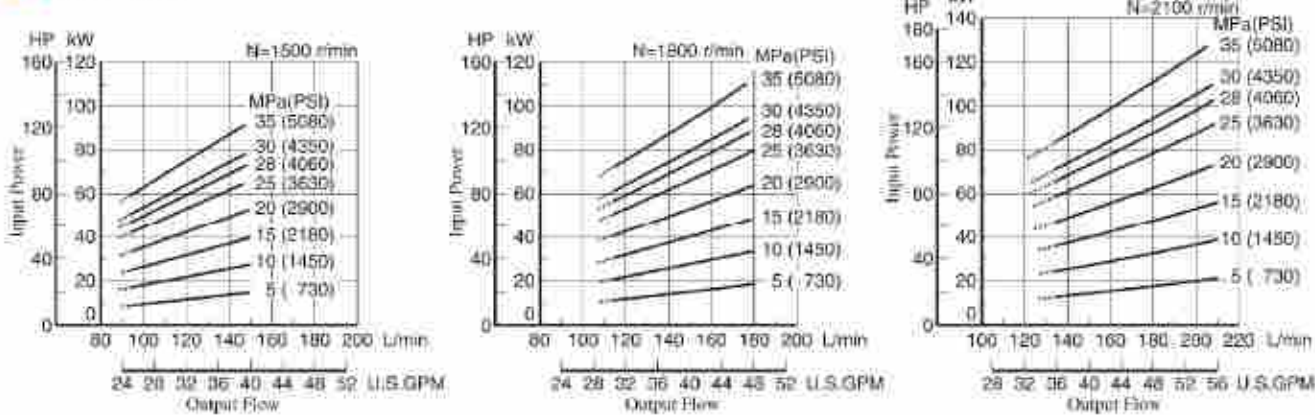

Note) The dotted line in the graph indicates less than minimum adjustable flow.

Full Cut-off Power

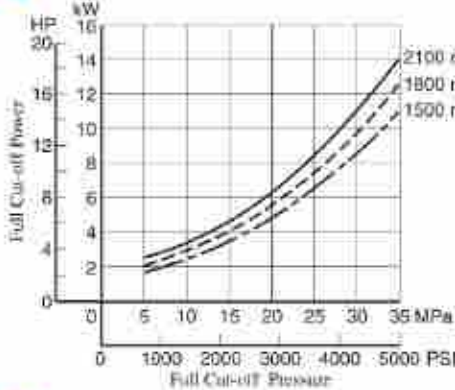

Drain

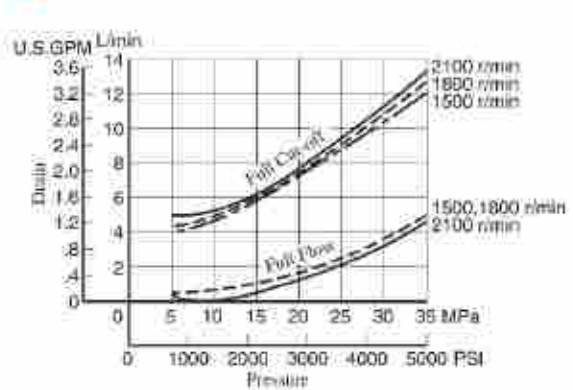

Noise Level (One metre (3.3 ft.) horizontally away from pump head cover)

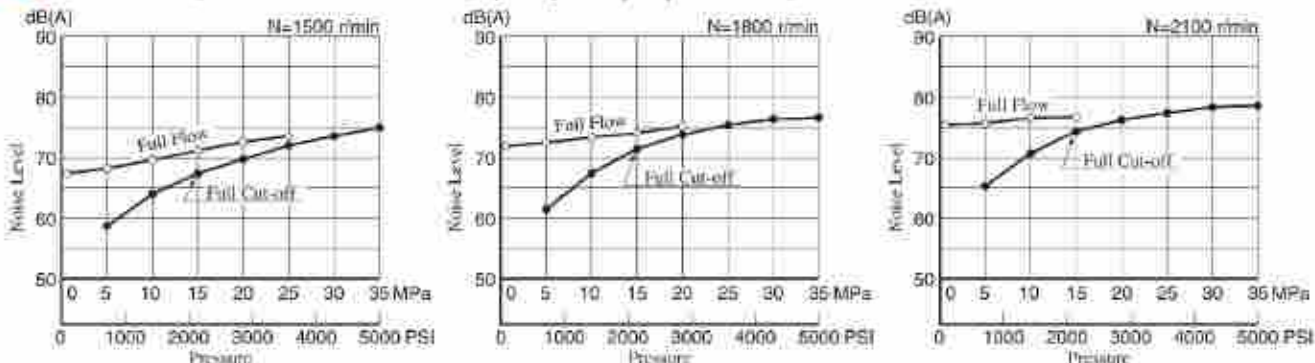

Typical Performance Characteristics of Type "A3H145" at Viscosity 32 mm²/s (150 SSU) [ISO VG32 oils, 40°C (104°F)]

Performance Characteristic Curve

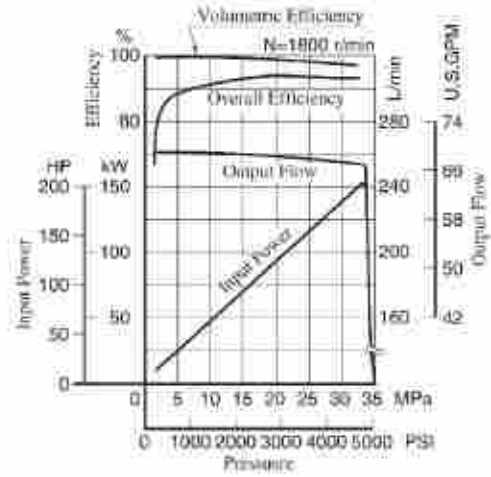
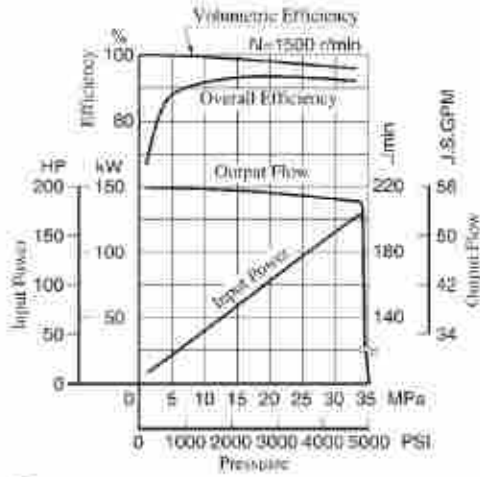

Input Power

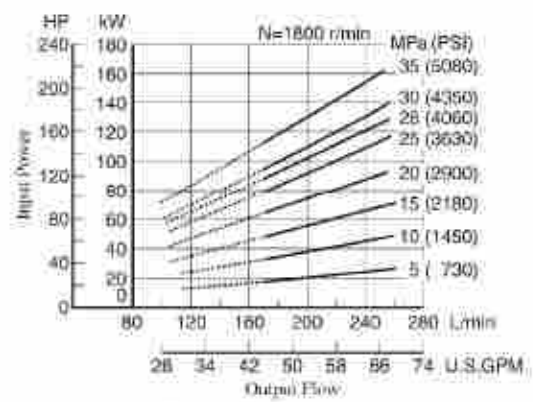
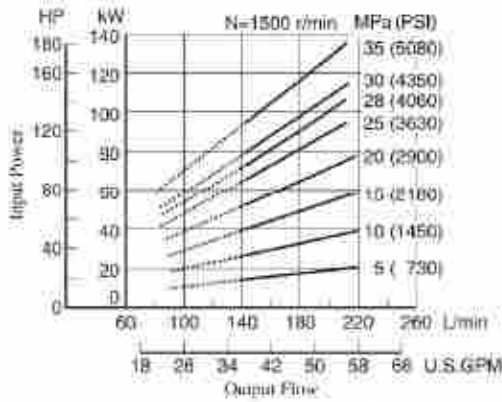

Note) The dotted line in the graph indicates less than minimum adjustable flow.

Full Cut-off Power

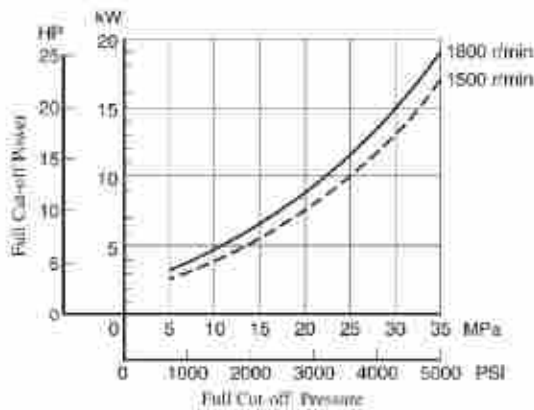

Drain

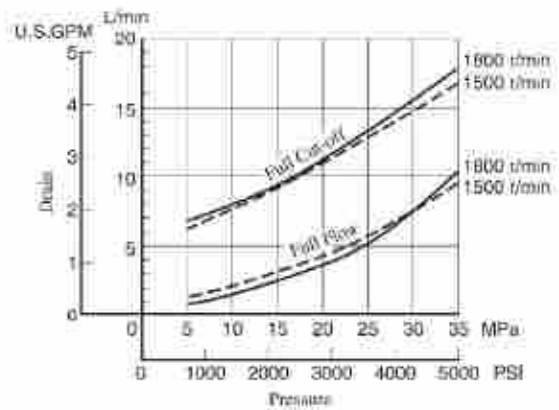

Noise Level [One metre (3.3 ft.) horizontally away from pump head cover]

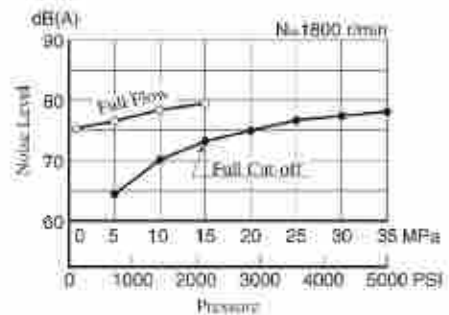
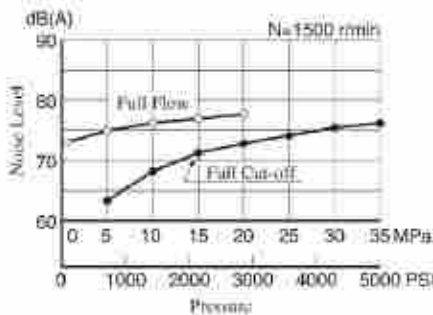



Typical Performance Characteristics of Type "A3H160" at Viscosity 32 mm²/s (150 SSU) [ISO VG32 oils, 40°C (104°F)]

■ Performance Characteristic Curve

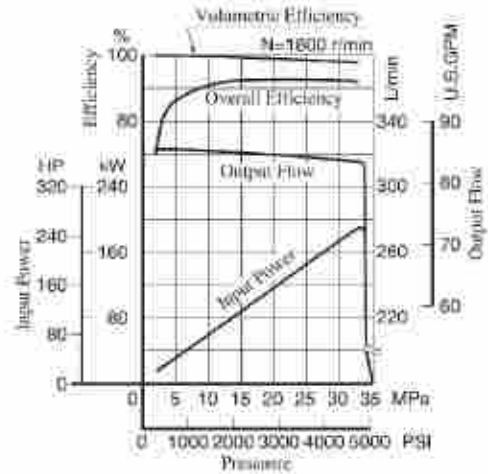
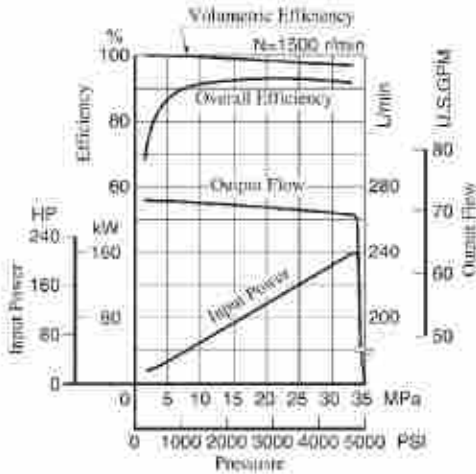

■ Input Power

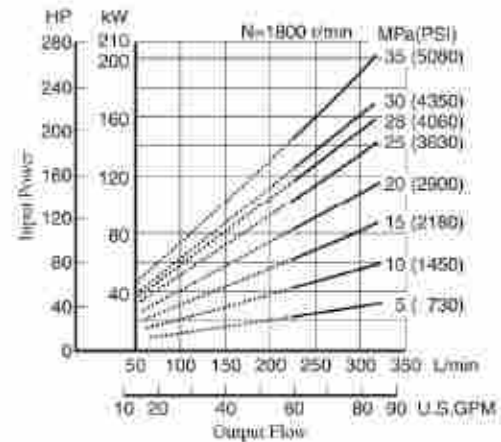
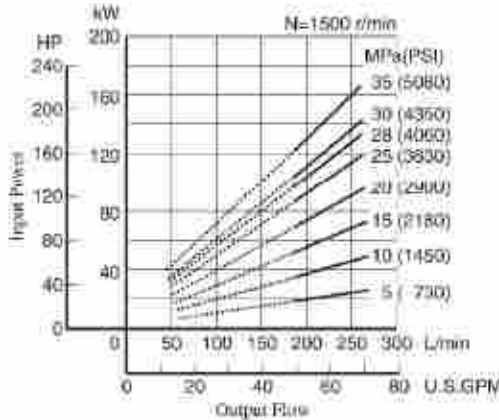

Note: The dotted line in the graph indicates less than minimum adjustable flow.

■ Full Cut-off Power

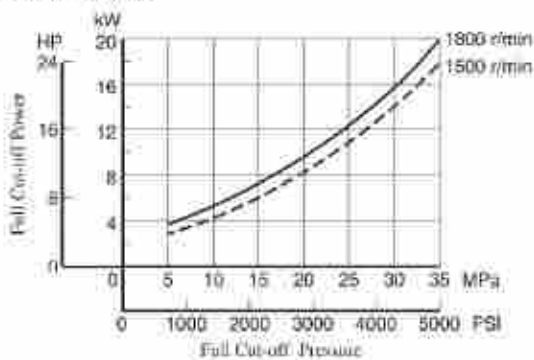

■ Drain

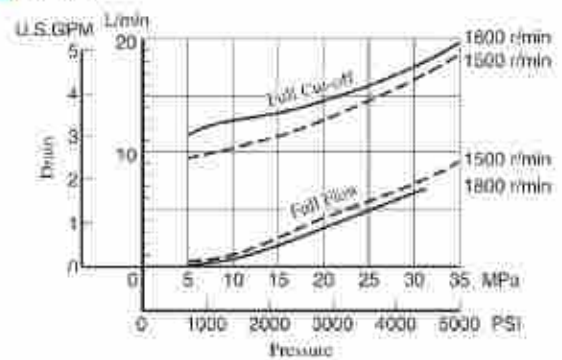

■ Noise Level (One metre (3.3 ft.) horizontally away from pump head cover)

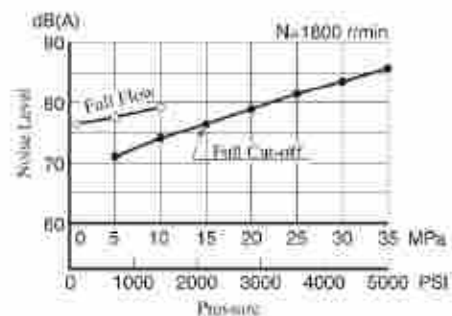
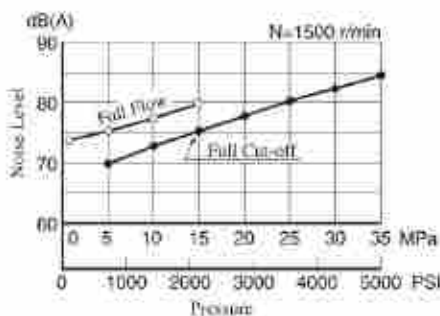

Flange Mtg.: A3H16-FR01KK-10/1080/10950

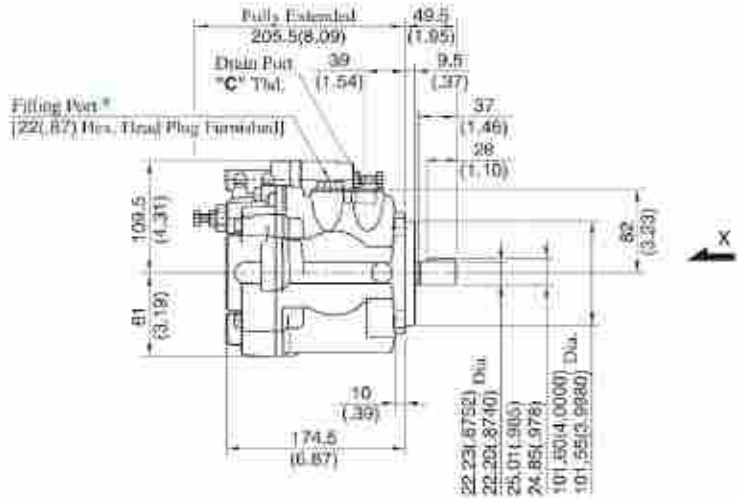
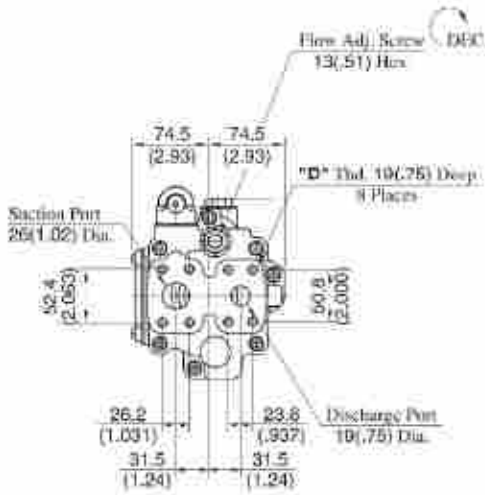

★ Install the pump so that the "Filling port" is at the top.

Model Numbers	"C" Thd.	"D" Thd.
A3H16-FR01KK-10	Rc 1/2	M10
A3H16-FR01KK-1080	1/2 BSP.F	
A3H16-FR01KK-10950	SAE#10	3/8-16 UNC

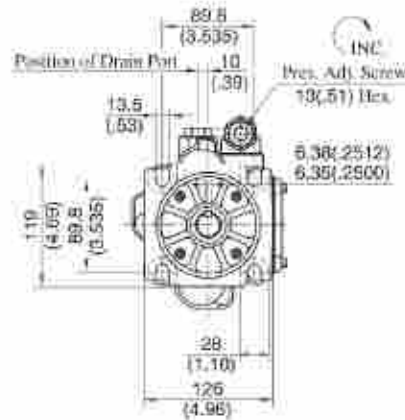

View Arrow X

DIMENSIONS IN MILLIMETRES (INCHES)

Foot Mtg.: A3H16-LR01KK-10/1080/10950

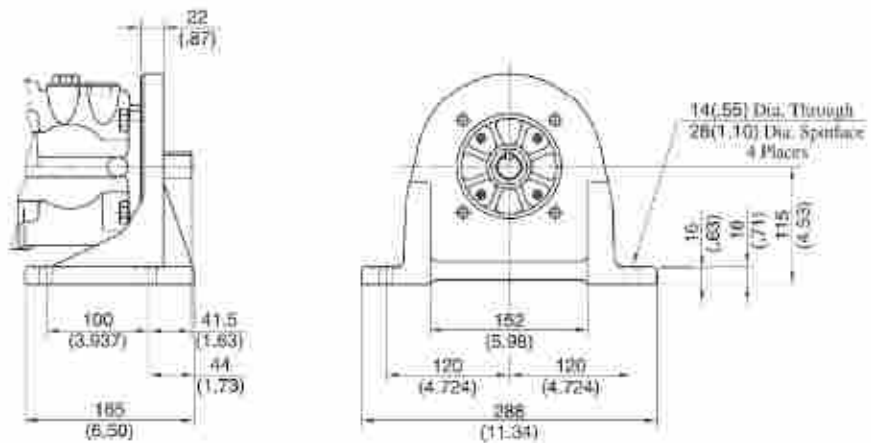

● For other dimensions, refer to "Flange Mtg."

Flange Mtg.: A3H37-FR01KK-10/1080/10950

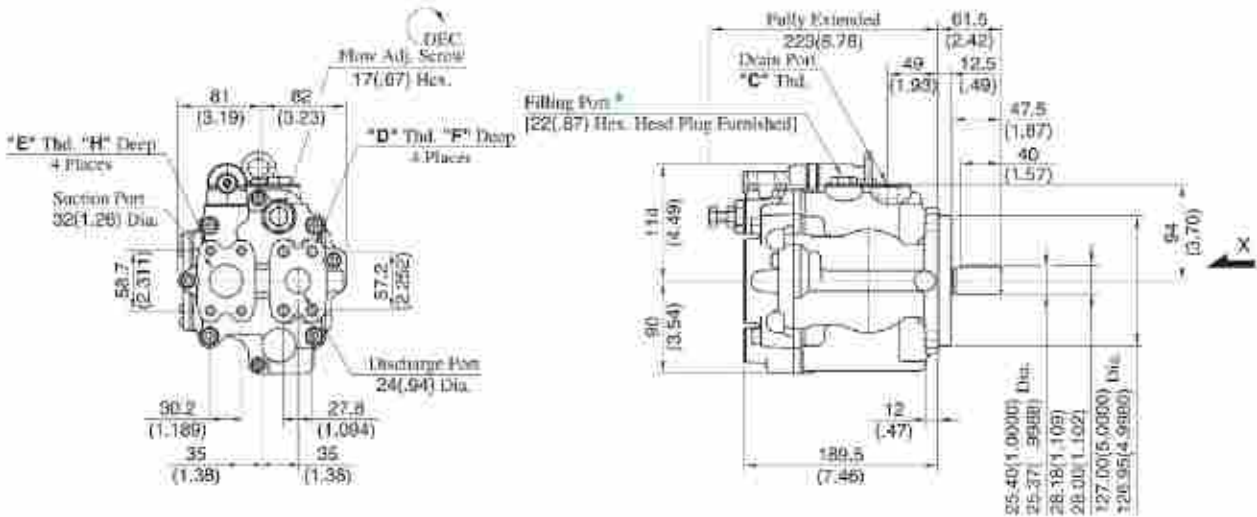

★ Install the pump so that the "Filling port" is at the top.

Model Numbers	"C" Thd.	"D" Thd.	"E" Thd.	F mm(N.)	H mm(N.)
A3H37-FR01KK-10	Rc 1/2	M12	M10	22 (.87)	18 (.71)
A3H37-FR01KK-1080	1/2 B5P.F				
A3H37-FR01KK-10950	SAE #10	1/2-13 UNC	7/16-14 UNC	21 (.83)	20 (.79)

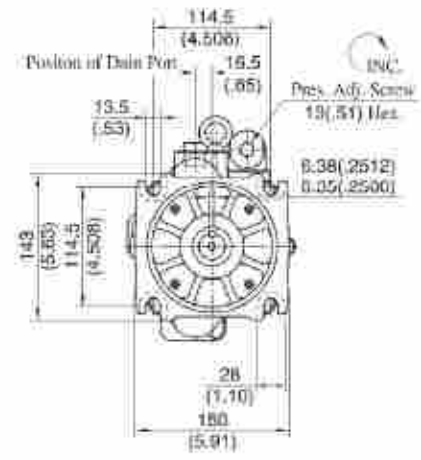

View Arrow X

DIMENSIONS IN MILLIMETRES (INCHES)

Foot Mtg.: A3H37-LR01KK-10/1080/10950

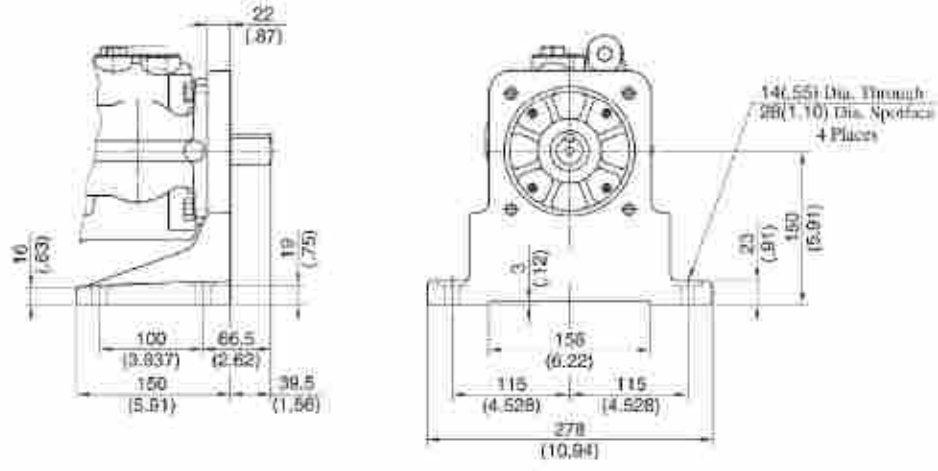

● For other dimensions, refer to "Flange Mtg."

Flange Mtg.: A3H56-FR01KK-10/1080/10950

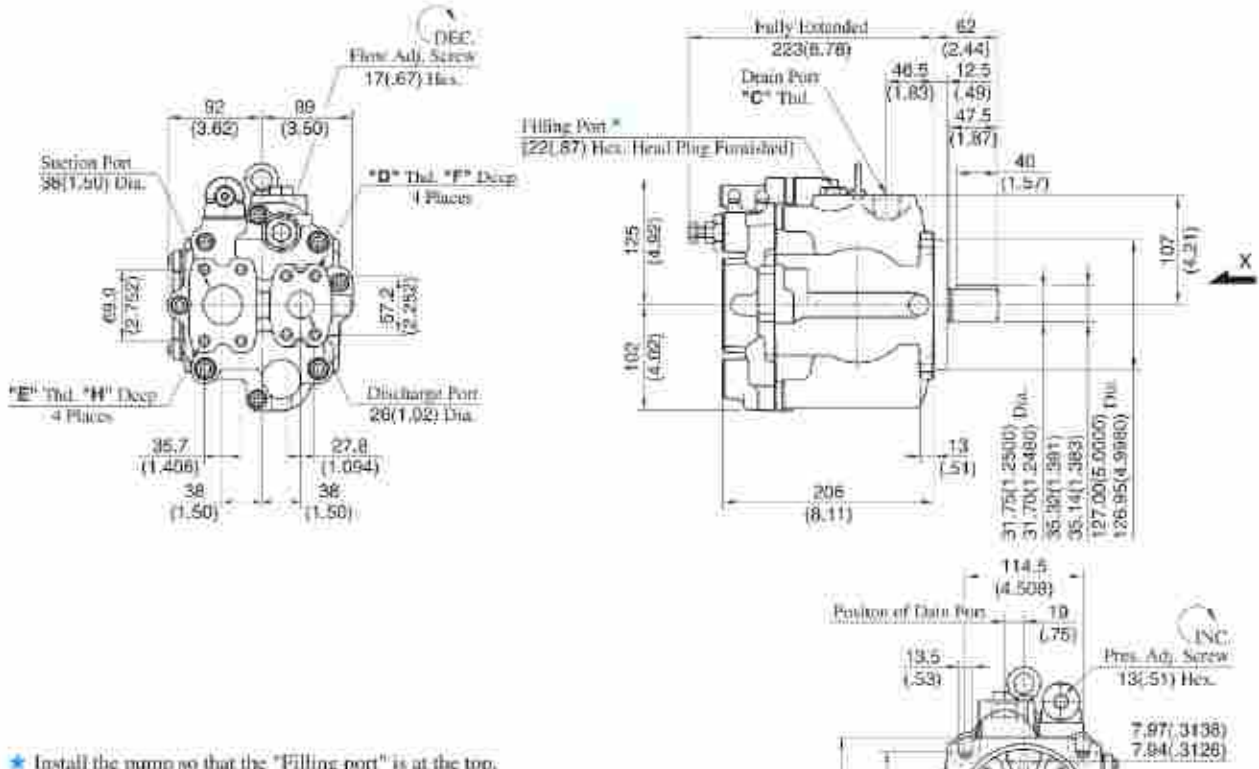

★ Install the pump so that the "Filling port" is at the top.

Model Numbers	"C" Thd.	"D" Thd.	"E" Thd.	F mm(IN.)	H mm(IN.)
A3H56-FR01KK-10	Re 3/4	M12	M12	22 (.87)	22 (.87)
A3H56-FR01KK-1080	3/4 BSP.F				
A3H56-FR01KK-10950	SAE #12	1/2-13 UNC	7/16-14 UNC	21 (.83)	20 (.79)

DIMENSIONS IN MILLIMETRES (INCHES)

Foot Mtg.: A3H56-LR01KK-10/1080/10950

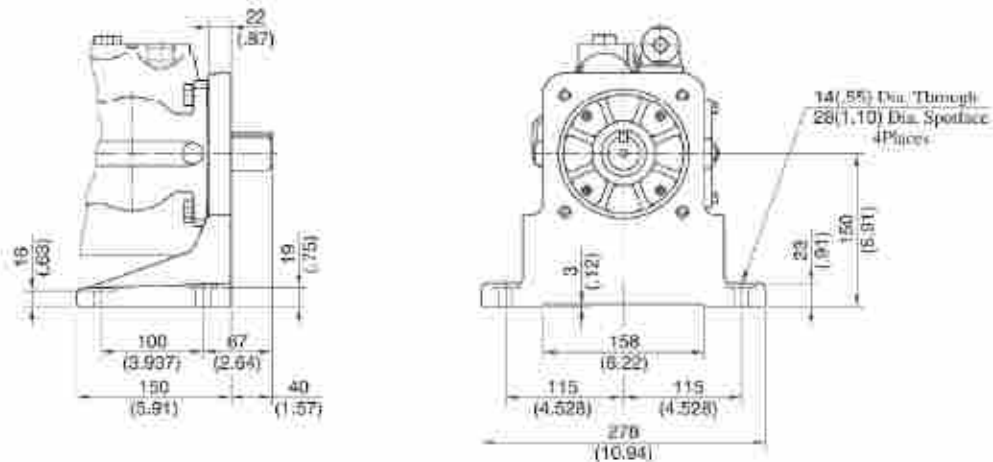

● For other dimensions, refer to "Flange Mtg."

Flange Mtg.: A3H71-FR01KK-10/1080/10950

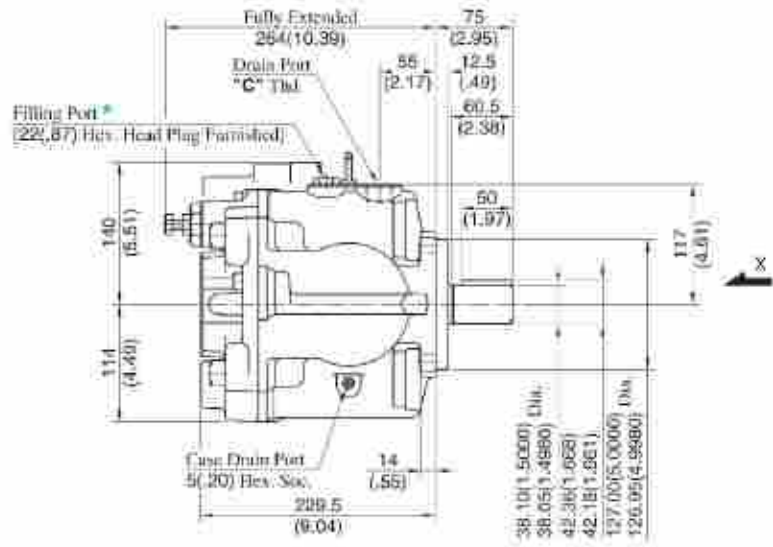
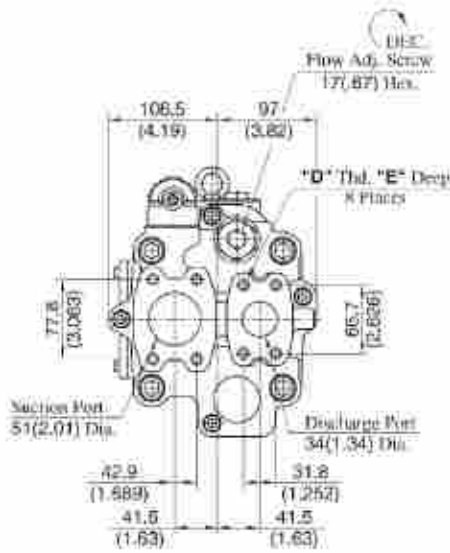

★ Install the pump so that the "Filling port" is at the top.

Model Numbers	"C" Thd.	"D" Thd.	E mm (IN.)
A3H71-FR01KK-10	Rc 3/4	M12	19 (.75)
A3H71-FR01KK-1080	1/4 BSP.F		
A3H71-FR01KK-10950	SAE #12	1/2-13 UNC	21 (.83)

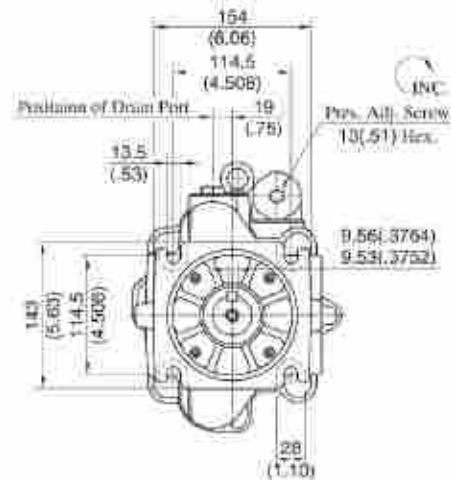

View Arrow X

DIMENSIONS IN MILLIMETRES (INCHES)

Foot Mtg.: A3H71-LR01KK-10/1080/10950

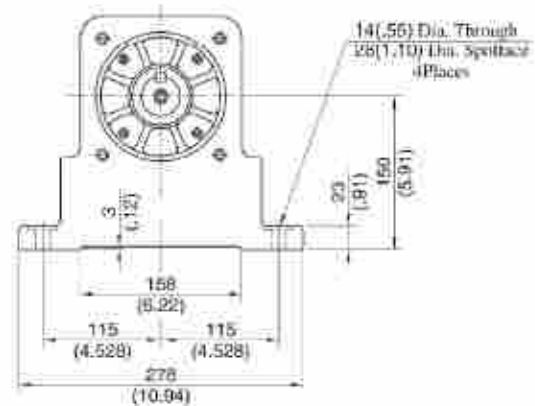
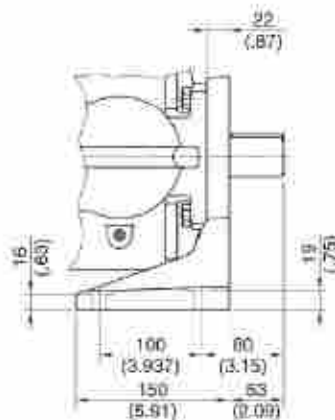

● For other dimensions, refer to "Flange Mtg."

Flange Mtg.: A3H100-FR01KK-10/1080/10954

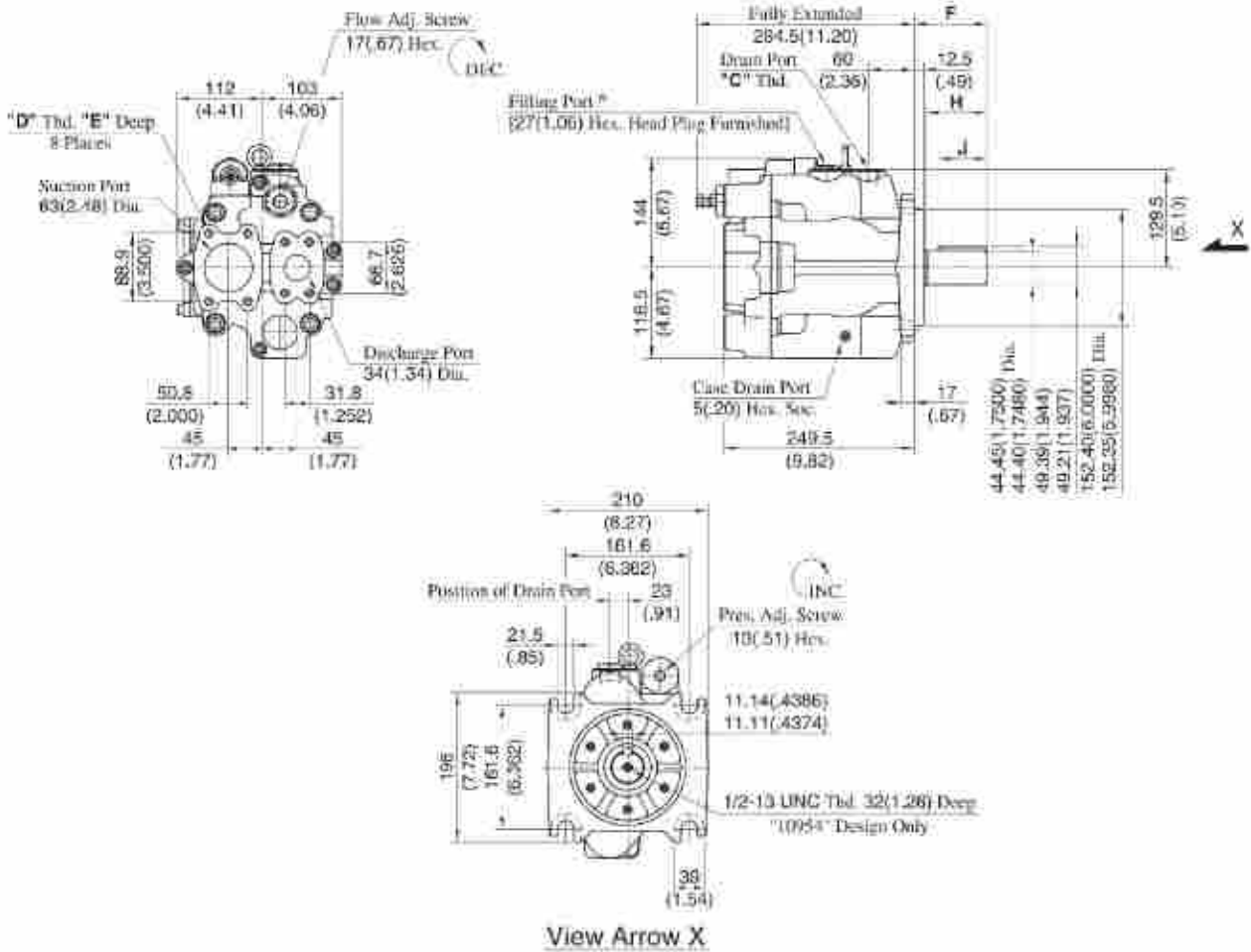

★ Install the pump so that the "Filling port" is at the top.

Model Numbers	Thread Size		Dimensions mm (Inches)			
	C	D	E	F	H	J
A3H100-FR01KK-10	Rc 3/4	M12	19 (.75)	95 (3.74)	81 (3.19)	63 (2.48)
A3H100-FR01KK-1080	3/4 BSP.F					
A3H100-FR01KK-10954	SAE #12	1/2-13 UNC	21 (.83)	74.6 (2.94)	60.6 (2.39)	50 (1.97)

DIMENSIONS IN MILLIMETRES (INCHES)

Foot Mtg.: A3H100-LR01KK-10/1080

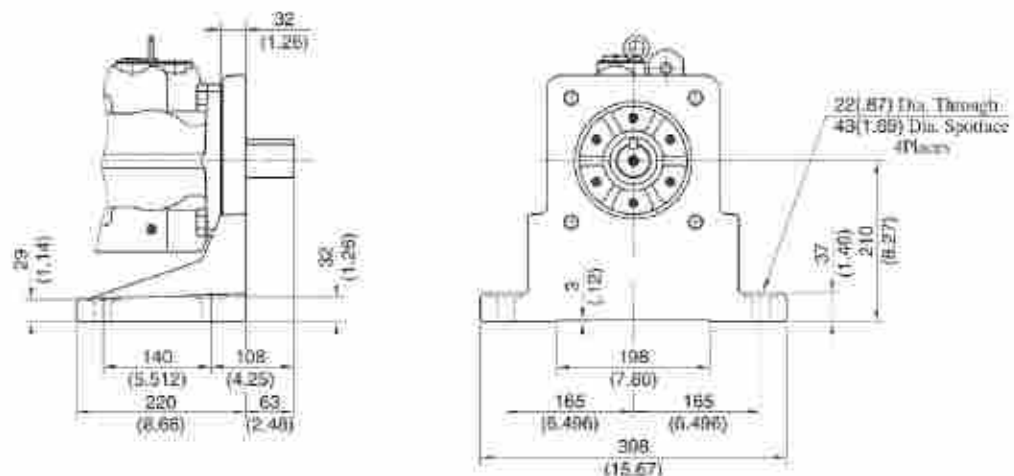

● For other dimensions, refer to "Flange Mtg."

Flange Mtg.: A3H145-FR01KK*-10/1080/10954

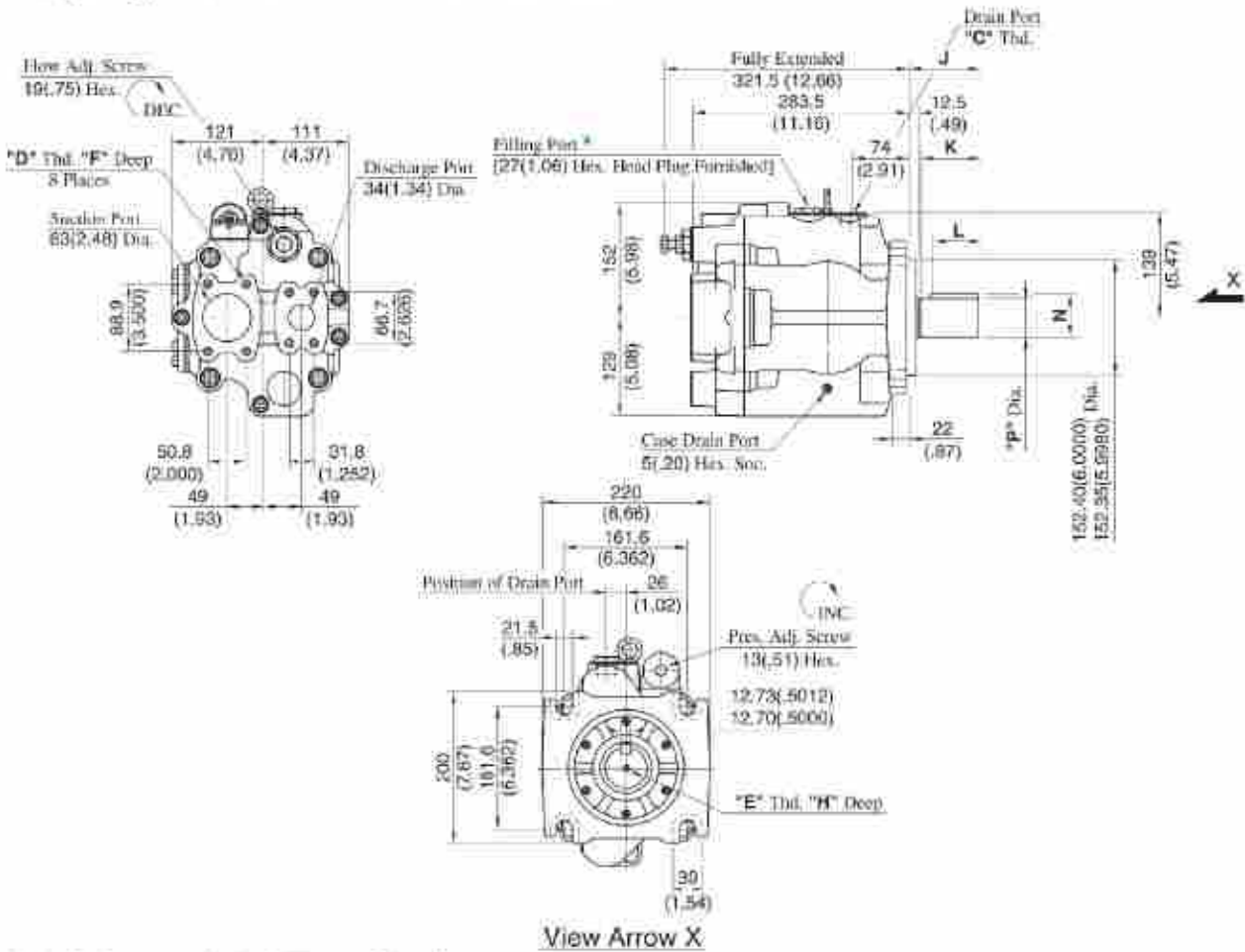

* Install the pump so that the "Filling port" is at the top.

Model Numbers	Thread Size			Dimensions - mm (Inches)						
	C	D	E	F	H	J	K	L	N	P
A3H145-FR01KK-10	Rc 3/4	M12	—	22 (.87)	—	95 (3.74)	81 (3.19)	63 (2.48)	49.39 (1.944)	44.45 (1.7500)
A3H145-FR01KK-1080	3/4 BSP.F								49.21 (1.937)	44.40 (1.7480)
A3H145-FR01KK-10954	SAE #12	1/2-13 UNC	1/2-13 UNC	21 (.83)	32 (1.26)	74.6 (2.94)	80.8 (3.19)	50 (1.97)	49.39 (1.944)	44.45 (1.7500)
A3H145-FR01KK1-10954									5/8-11 UNC	36 (1.42)
									56.25 (2.215)	50.75 (1.9980)

DIMENSIONS IN MILLIMETRES (INCHES)

Foot Mtg.: A3H145-LR01KK-10/1080

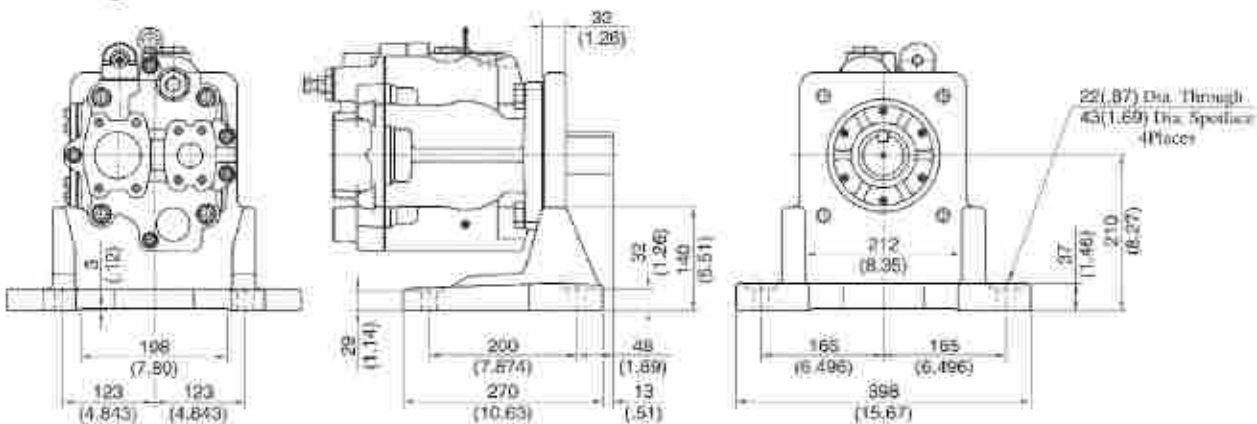

Flange Mtg.: A3H180-FR01KK-10/1080/10954

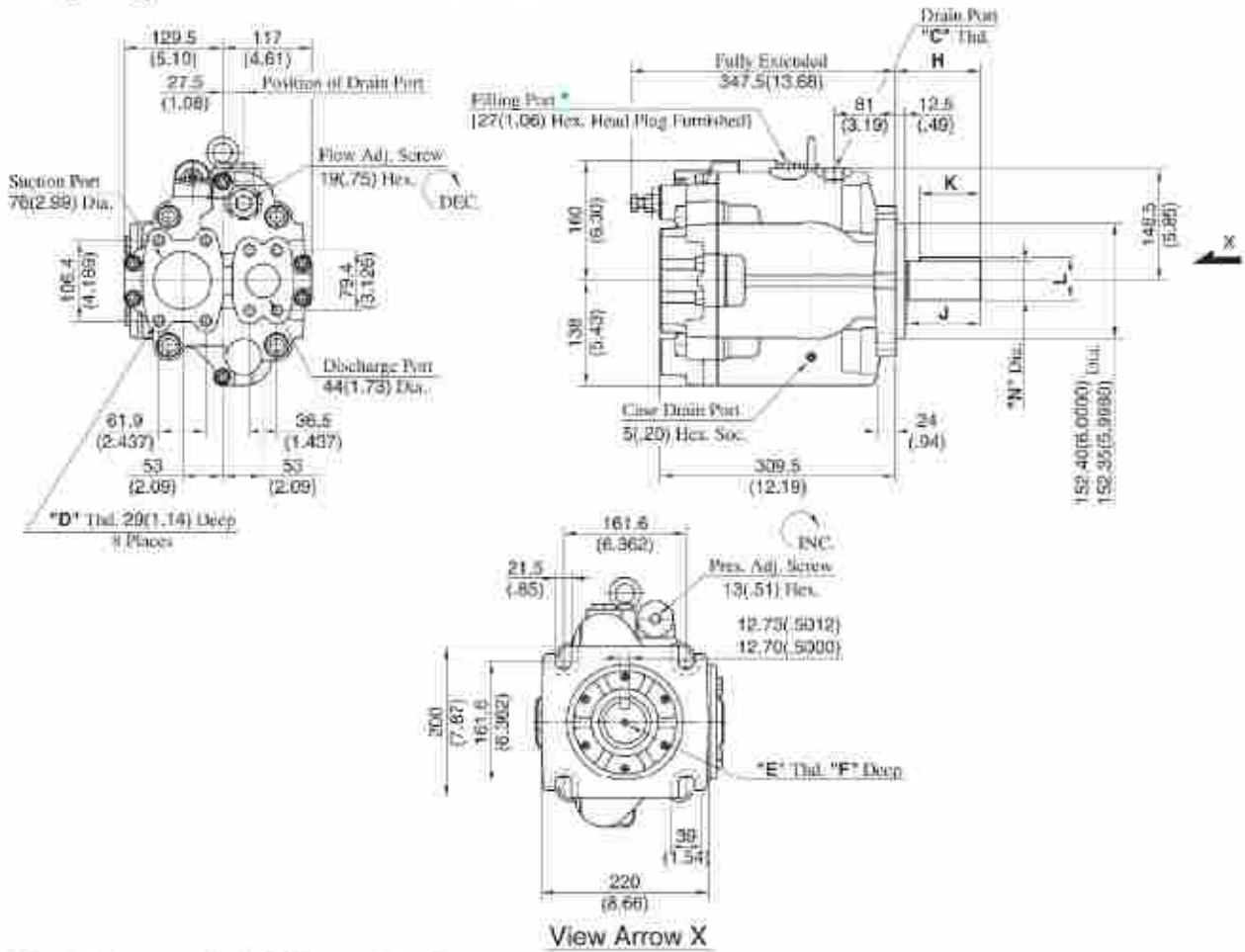

★ Install the pump so that the "filling port" is at the top.

Model Numbers	Thread Size		Dimensions mm (Inches)							
	C	D	E	F	H	J	K	L	N	
A3H180-FR01KK-10	Rc 3/4	M12	—	—	112 (4.41)	97.5 (3.84)	80 (3.15)	56.43 (2.222)	50.80 (2.0000)	
A3H180-FR01KK-1080	3/4 BSP.F							56.25 (2.215)	50.75 (1.9980)	
A3H180-FR01KK-10954	SAE #12	5/8-11 UNC	1/2-13 UNC	32 (1.26)	74.6 (2.94)	60.6 (2.39)	50 (1.97)	49.39 (1.944)	44.45 (1.7500)	
A3H180-FR01KKI-10954			5/8-11 UNC	36 (1.42)				56.43 (2.222)	50.80 (2.0000)	
								56.25 (2.215)	50.75 (1.9980)	

DIMENSIONS IN MILLIMETRES (INCHES)

Foot Mtg.: A3H180-LR01KK-10/1080

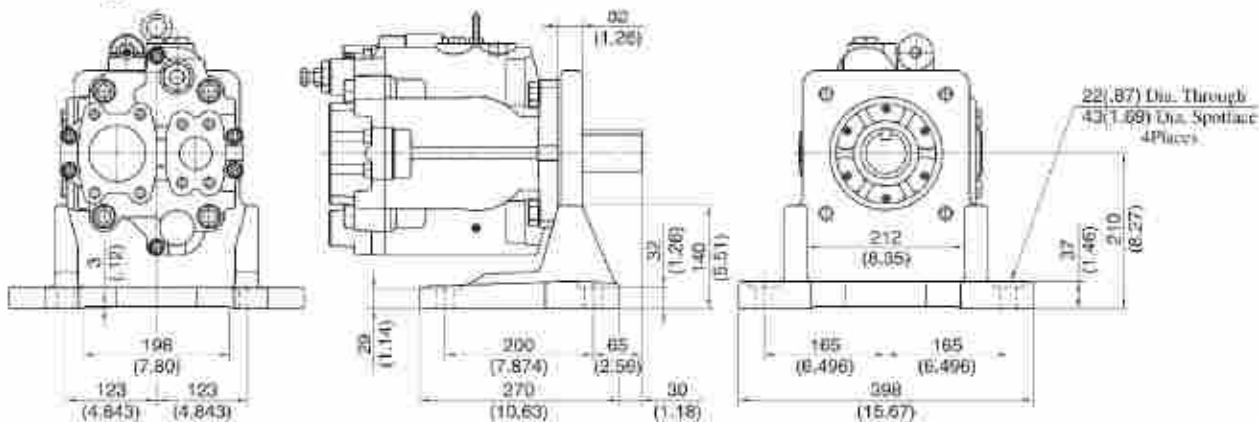

● For other dimensions, refer to "Flange Mtg."

■ Spare Parts List

A3H16/A3H37/A3H56-★R01KK-10/1080/10950

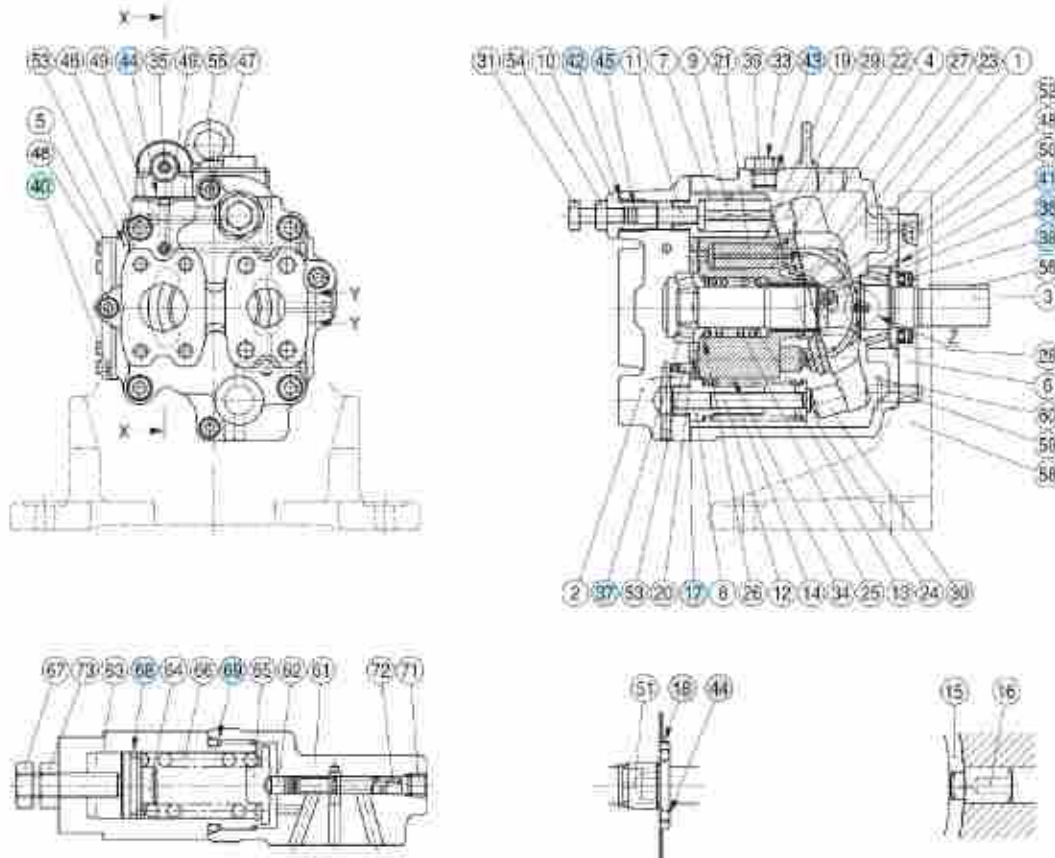

Detail of Section X – X

Detail of Section Y – Y

Detail of "Z"

● List of Seals and Bearings

Item	Name of Parts	Part Numbers			Qty.
		A3H16	A3H37	A3H56	
17*	Gasket	2270-PK313655-3	2271-PK-313518-3	2272-PK313433-3	1
18*	Back Up Ring		1310E-PK412440-0		1
36	Cylindrical Roller Bearing	NUP205E			1
	Tapered Roller Bearing		4T-30204	4T-33008	
37	Needle Roller Bearing	HMK2025V2			1
	Tapered Roller Bearing		4T-33006	4T-32205R	
38*	Oil Seal	TCN254511 (FKM)	TCN284811 (FKM)	TCN355311 (FKM)	1
40*	O-Ring	S65 (NBR, H _v 70)	S85 (NBR, H _v 70)	S95 (NBR, H _v 70)	1
41*	O-Ring	SO-NA-G60	SO-NA-G60	S71 (NBR, H _v 70)	1
42*	O-Ring	SO-NB-P14	SO-NB-P18	SO-NB-P21	1
43*	O-Ring		SO-NB-P14		1
44*	O-Ring		SO-NB-P9		4
45*	O-Ring	SO-NB-P6	SO-NB-P8	SO-NB-P9	1
68*	O-Ring		SO-NA-A018		1
69*	O-Ring		SO-NB-P26		1

* When ordering seals, please specify the kit number from the table below.

● List of Seals kit

Pump Model Numbers	Seal Kit Numbers
A3H16-★R01KK-10/1080/10950	A3H16-01-10
A3H37-★R01KK-10/1080/10950	A3H37-01-10
A3H56-★R01KK-10/1080/10950	A3H56-01-10

Spear Parts List

A3H71-*R01KK-10/1080/10950
 A3H100/A3H145/A3H180-*R01KK*-10/1080/10954

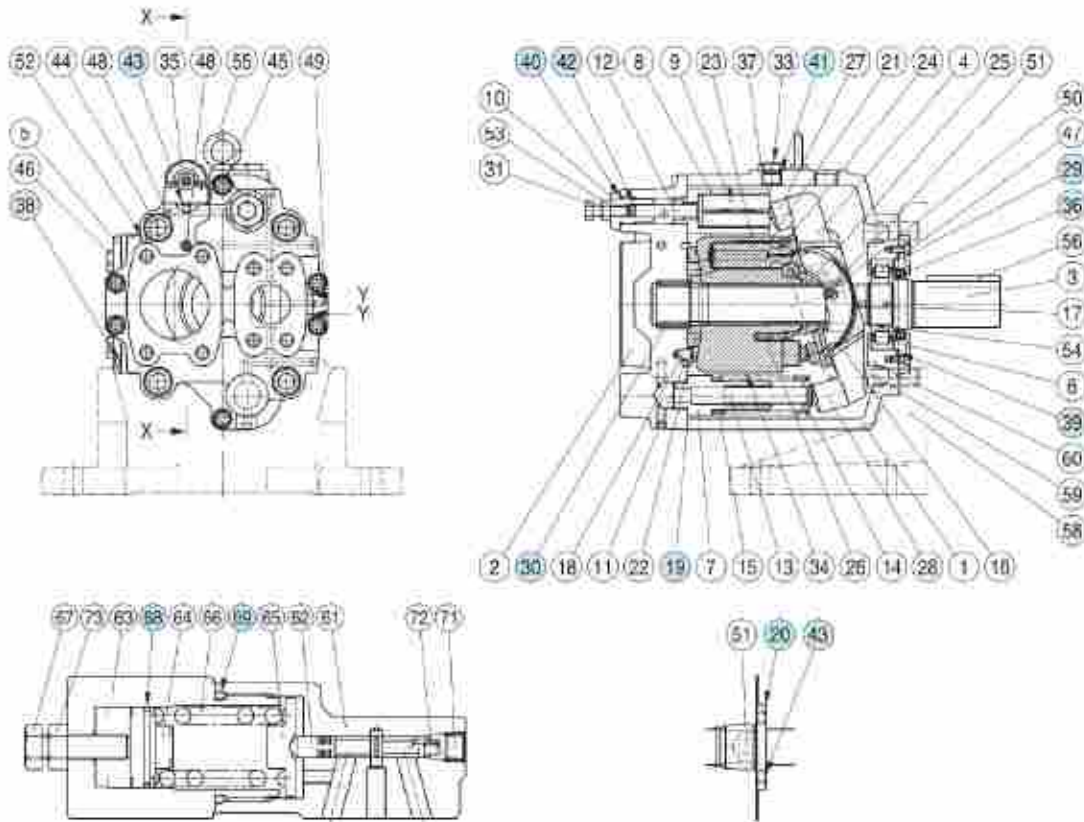

Detail of Section X – X

Detail of Section Y – Y

List of Seals and Bearings

Item	Name of Parts	Part Numbers				Qty.
		A3H71	A3H100	A3H145	A3H180	
19*	Gasket	2273-PK212356-0	2274-PK212368-5	2275-PK212382-6	2276-PK212301-6	1
20*	Back Up Ring	1310E-PK412440-0				1
29	Tapered Roller Bearing	3300JR	4T-33206	HR33011	—	1
	Cylindrical Roller Bearing	—	—	—	2276-PK412859-1	
30	Tapered Roller Bearing	3220JR	4T-30210	4T-35206	—	1
	Needle Roller Bearing	—	—	—	2276-PK412860-9	
36*	Oil Seal	TCN426512 (FKM)	TCN507212 (FKM)	TCN557812 (FKM)	TCN557812 (FKM)	1
38*	O-Ring	S100 (NBR, Hs70)	S110 (NBR, Hs70)	S125 (NBR, Hs70)	S130 (NBR, Hs70)	1
39*	O-Ring	SO-NA-G80	SO-NA-G95	SO-NA-G95	SO-NA-G105	1
40*	O-Ring	SO-NB-P24		SO-NB-P26		1
41*	O-Ring	SO-NB-P14	SO-NB-P18	SO-NB-P10		1
42*	O-Ring	SO-NB-P9		SO-NB-P10A		1
43*	O-Ring	SO-NB-P9				4
68*	O-Ring	SO-NA-A021				1
69*	O-Ring	SO-NB-P32				1

* When ordering seals, please specify the kit number from the table below.

List of Seals kit

Pump Model Numbers	Seal Kit Numbers
A3H71-*R01KK-10/1080/10950	A3H71-01-10
A3H100-*R01KK-10/1080/10954	A3H100-01-10
A3H145-*R01KK-10/1080/10954	A3H145-01-10
A3H180-*R01KK-10/1080/10954	A3H180-01-10



"A3H" Series Variable Displacement Piston Pumps-Single Pump, Constant Power (Torque) Control Type



Graphic Symbol

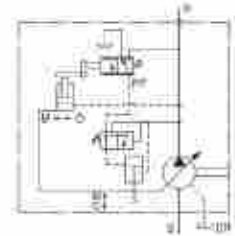

Specifications

Model Numbers	Geometric Displacement cm ³ /rev (cu.in./rev)	Minimum Adj. Flow cm ³ /rev (cu.in./rev)	Max. Operating Pressure MPa (PSI)	Shaft Speed Range r/min		Approx. Mass kg (lbs.)	
				Max.*	Min.	Flange Mtg.	Foot Mtg.
A3H 37-#R09-##K-10#	37.1 (2.26)	16.0 (0.976)	35 (5080)	2700	600	23.0 (50.7)	30.5 (67.3)
A3H 56-#R09-##K-10#	56.3 (3.44)	35.0 (2.14)		2500	600	29.0 (63.9)	36.5 (80.5)
A3H 71-#R09-##K-10#	70.7 (4.31)	45.0 (2.75)		2300	600	38.0 (83.8)	45.5 (100)
A3H100-#R09-##K-10#	100.5 (6.13)	63.0 (3.84)		2100	600	48.0 (106)	76.0 (168)
A3H145-#R09-##K-10#	145.2 (8.86)	95.0 (5.80)		1800	600	63.0 (139)	91.0 (201)
A3H180-#R09-##K-10#	180.7 (11.03)	125.0 (7.63)		1800	600	74.2 (164)	102.2 (225)

* The maximum shaft speeds shown in the above table are at suction pressure 0 kPa (0 PSIG).

Model Number Designation

A3H37	-F	R	09	-11	A	4	K	-10	#
Series Number	Mounting	Direction of Rotation	Control Type	Input Power Setting	Frequency of Power Source	Pole Number of Electric Motor	Shaft Extension*	Design Number	Design Std.
A3H37 (37.1 cm ³ /rev)	F: Flange Mtg. L: Foot Mtg.	(Viewed from Shaft End)	09: Constant Power (Torque) Control Type	5.5: 5.5 kW 110: 110 kW Refer to the table on following page for combination.	A: 50 Hz B: 60 Hz	4: 4 Poles 6: 6 Poles	K: Keyed Shaft	10	Refer to ★3
A3H56 (56.3 cm ³ /rev)								10	
A3H71 (70.7 cm ³ /rev)	F: Flange Mtg. L: Foot Mtg.*	R: Clockwise* (Normal)	09: Constant Power (Torque) Control Type	5.5: 5.5 kW 110: 110 kW Refer to the table on following page for combination.	A: 50 Hz B: 60 Hz	4: 4 Poles 6: 6 Poles	K: Keyed Shaft [44.45mm (1.75 IN.) Dia.] K1: Keyed Shaft** [50.8mm (2.0 IN.) Dia.]	10	
A3H100 (100.5 cm ³ /rev)								10	
A3H145 (145.2 cm ³ /rev)								10	
A3H180 (180.7 cm ³ /rev)								10	

★1: Available to supply pump with anti-clockwise rotation. Consult Yuken for details.

★2: We can also supply spline-type shaft extension. Consult Yuken for details.

★3: Design Standards: None _____ Japanese Standard "JIS"

80 _____ European Design Standard

950 _____ N. American Design Standard (Applicable only for A3H37/56/71)

954 _____ N. American Design Standard (Applicable only for A3H100/145/180)

★4: Mounting type "L" is not available for N. American Design Standard.

★5: Shaft extension "K1" is applicable only for N. American Design Standard.

● **Combination of pump series and input power setting (○ = available combinations)**

Model Numbers		Input Power Setting: kW (HP)																					
		Pole Number of Electric Motor: 4P									Pole Number of Electric Motor: 6P												
		11 (15)	15 (20)	18.5 (25)	22 (30)	30 (40)	37 (50)	45 (60)	55 (75)	75 (100)	90 (120)	110 (150)	5.5 (7.5)	7.5 (10)	11 (15)	15 (20)	18.5 (25)	22 (30)	30 (40)	37 (50)	45 (60)	55 (75)	75 (100)
A3H 37	50 Hz	○	○	○									○	○	○								
	60 Hz	○	○	○	○								○	○	○								
A3H 56	50 Hz		○	○	○	○								○	○	○							
	60 Hz		○	○	○	○	○							○	○	○	○						
A3H 71	50 Hz			○	○	○	○	○						○	○	○	○						
	60 Hz			○	○	○	○	○	○					○	○	○	○	○					
A3H100	50 Hz				○	○	○	○	○						○	○	○	○	○				
	60 Hz				○	○	○	○	○	○					○	○	○	○	○	○			
A3H145	50 Hz					○	○	○	○	○						○	○	○	○	○			
	60 Hz						○	○	○	○	○		○			○	○	○	○	○	○		
A3H180	50 Hz							○	○	○	○						○	○	○	○	○		
	60 Hz							○	○	○	○	○					○	○	○	○	○	○	○

■ **Pipe Flange Kits**

For pipe flange, refer to form of pressure compensator type on page 123.

Typical Performance Characteristics of Control Type "09" at Viscosity 32 mm²/s [ISO VG32 oils, 40°C (104°F)]

● **A3H37**

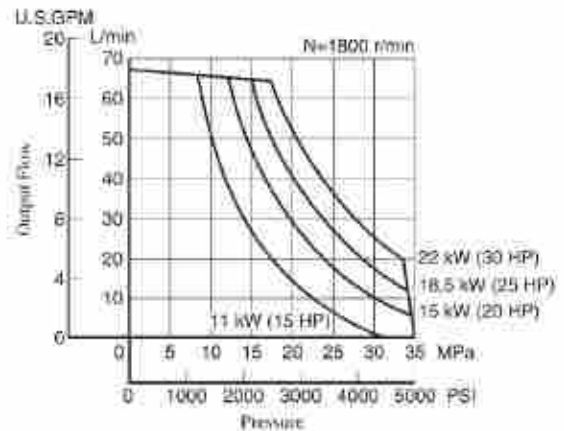
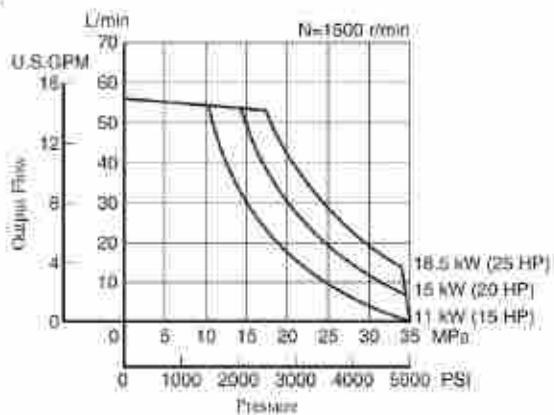

● **A3H56**

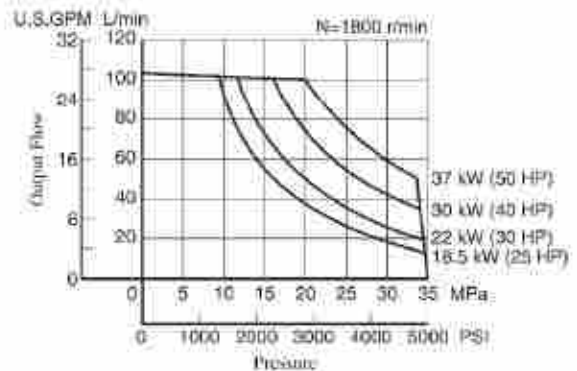
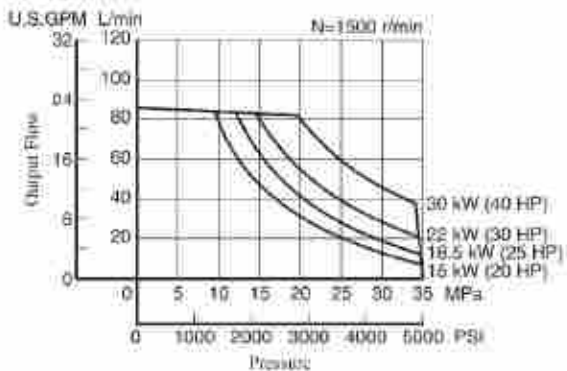



Typical Performance Characteristics of Control Type *09* at Viscosity 32 mm²/s [ISO VG32 oils, 40°C (104°F)]

● A3H71

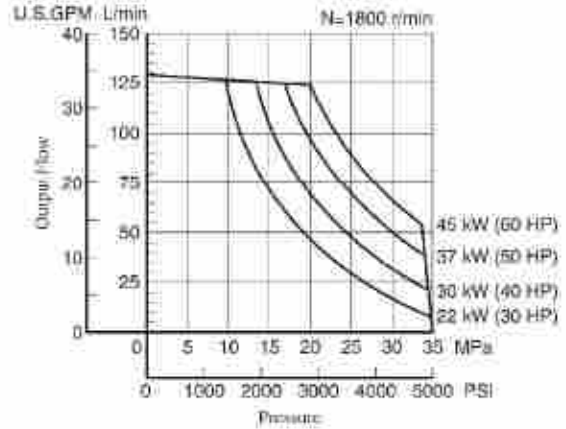
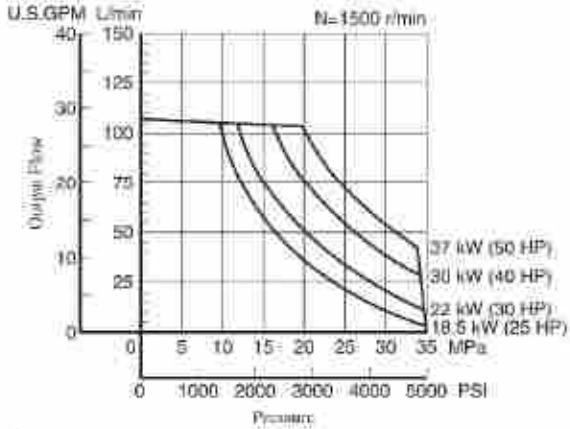

● A3H100

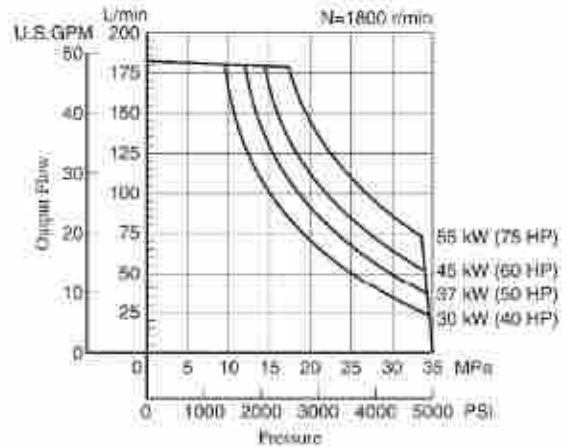
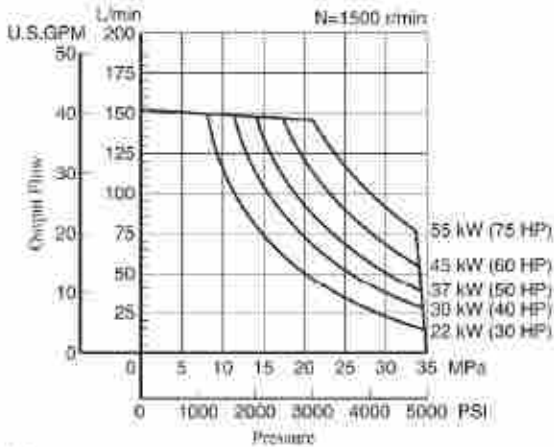

● A3H145

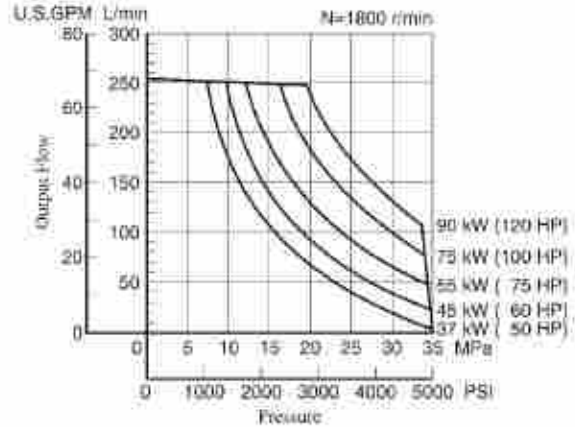
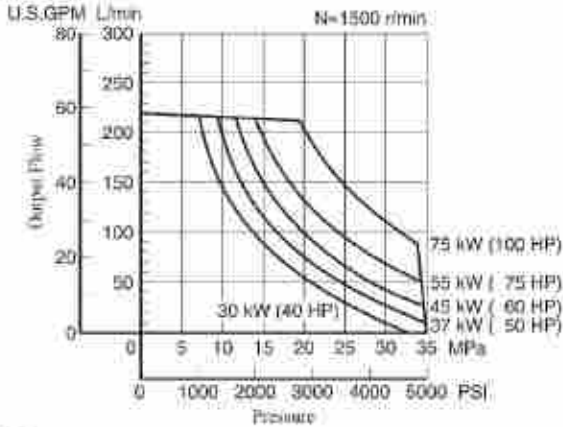

● A3H180

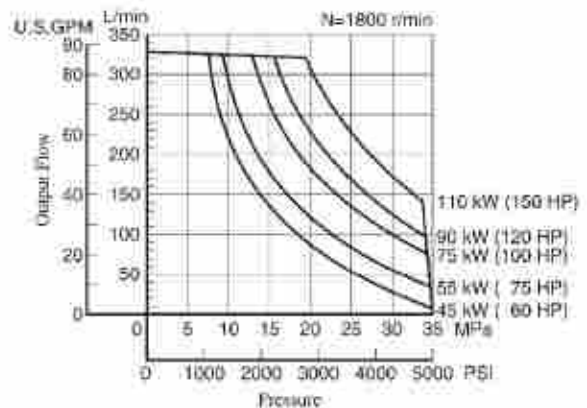
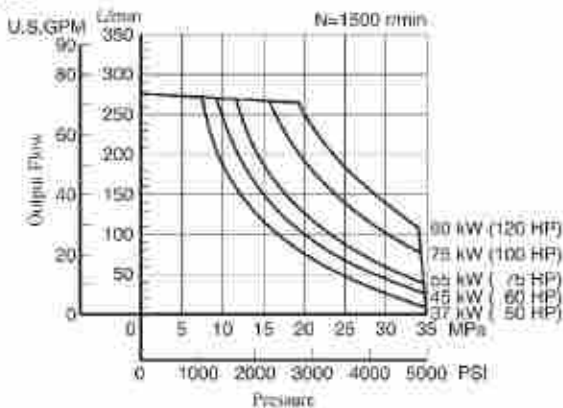

Flange Mtg.: A3H37-FR09-***K-10/1080/10950

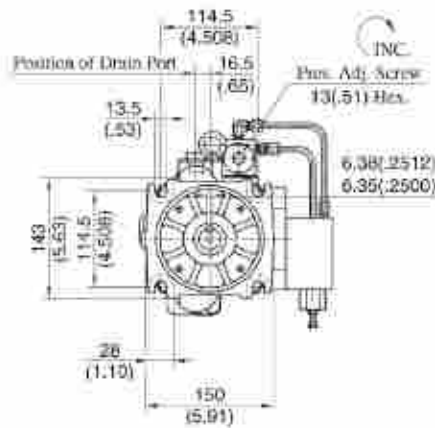
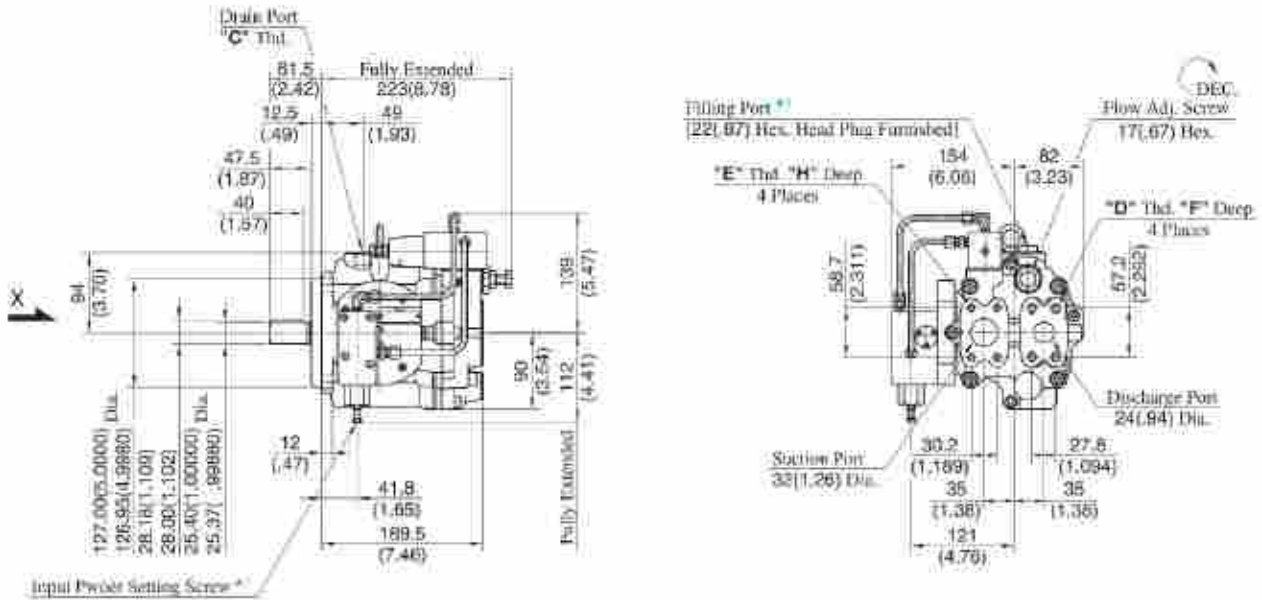

View Arrow X

Model Numbers	Thread Size			Dimensions mm (Inches)	
	C	D	E	F	H
A3H37-FR09-***K-10	Rc 1/2	M12	M10	22 (.87)	18 (.71)
A3H37-FR09-***K-1080	1/2 BSP.F				
A3H37-FR09-***K-10950	SAE #10	1/2-13 UNC	7/16-14 UNC	21 (.83)	20 (.79)

- ★ 1. Install the pump so that the "Filling Port" is at the top.
- ★ 2. Do not touch the screw because it is adjusted at the time of shipment.

DIMENSIONS IN MILLIMETRES (INCHES)

Foot Mounting Type

Mounting bracket is common to that of pressure compensator model. Refer to page 133 for the dimensions of mounting bracket.

Flange Mtg.: A3H56-FR09-***K-10/1080/10950

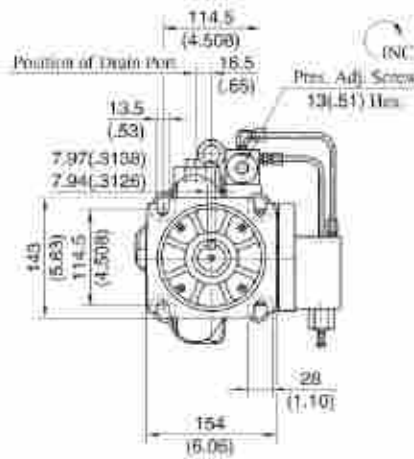
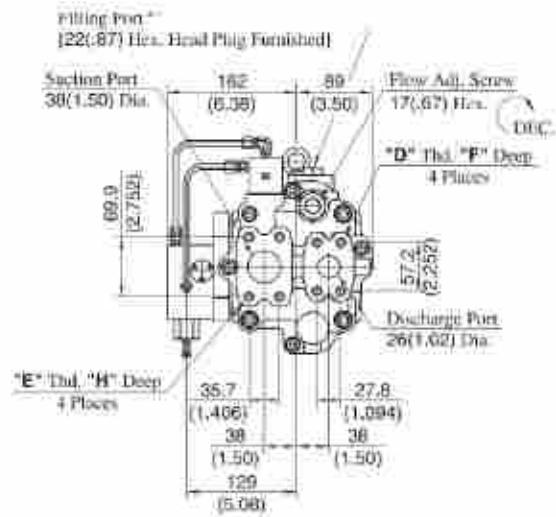
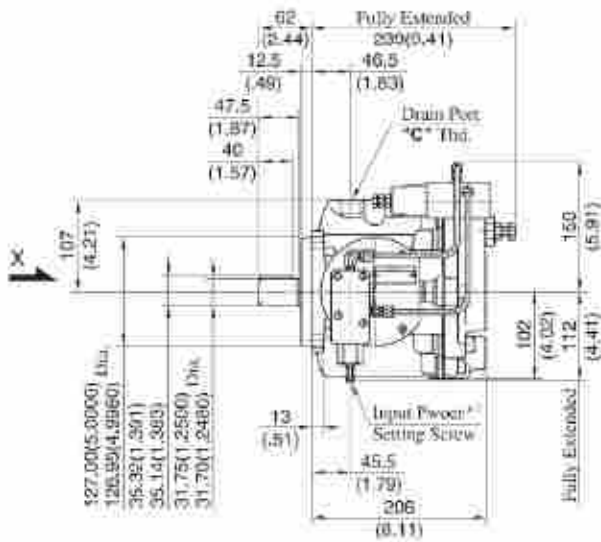

View Arrow X

Model Numbers	Thread Size			Dimensions mm (Inches)	
	C	D	E	F	H
A3H56-FR09-***K-10	Re 3/4	M12	M12	22 (.87)	22 (.87)
A3H56-FR09-***K-1080	3/4 BSP.F				
A3H56-FR09-***K-10950	SAE #12	1/2-13 UNC	7/16-14 UNC	21 (.83)	20 (.79)

- * 1. Install the pump so that the "Filling Port" is at the top.
- * 2. Do not touch the screw because it is adjusted at the time of shipment.

DIMENSIONS IN
MILLIMETRES (INCHES)

● Foot Mounting Type

Mounting bracket is common to that of pressure compensator model.
 Refer to page 134 for the dimensions of mounting bracket.

Flange Mtg.: A3H71-FR09-***K-10/1080/10950

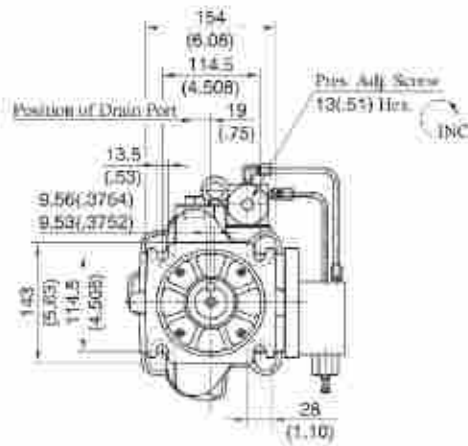
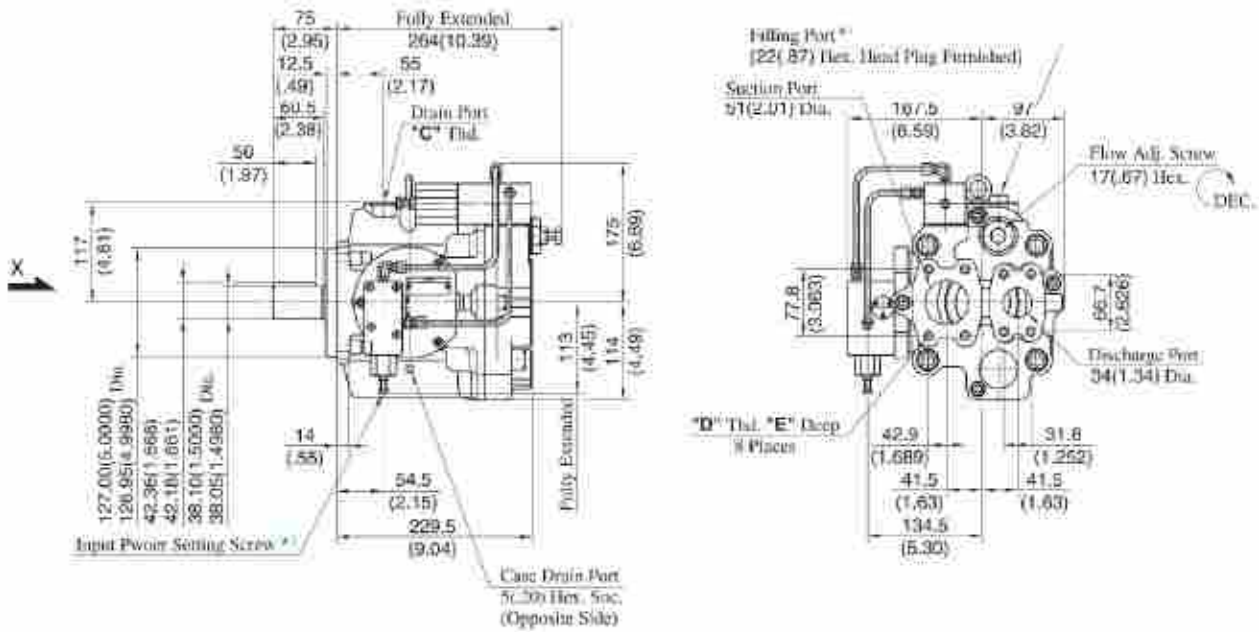

View Arrow X

Model Numbers	Thread Size		Dimensions mm (Inches)
	C	D	
A3H71-FR09-***K-10	Rc 3/4	M12	19 (.75)
A3H71-FR09-***K-1080	3/4 BSP.F		
A3H71-FR09-***K-10950	SAE #12	1/2-13 UNC	21 (.83)

- ★ 1. Install the pump so that the "Filling Port" is at the top.
- ★ 2. Do not touch the screw because it is adjusted at the time of shipment.

**DIMENSIONS IN
MILLIMETRES (INCHES)**

● Foot Mounting Type

Mounting bracket is common to that of pressure compensator model.
 Refer to page 135 for the dimensions of mounting bracket.

Flange Mtg.: A3H100-FR09-***K-10/1080/10954

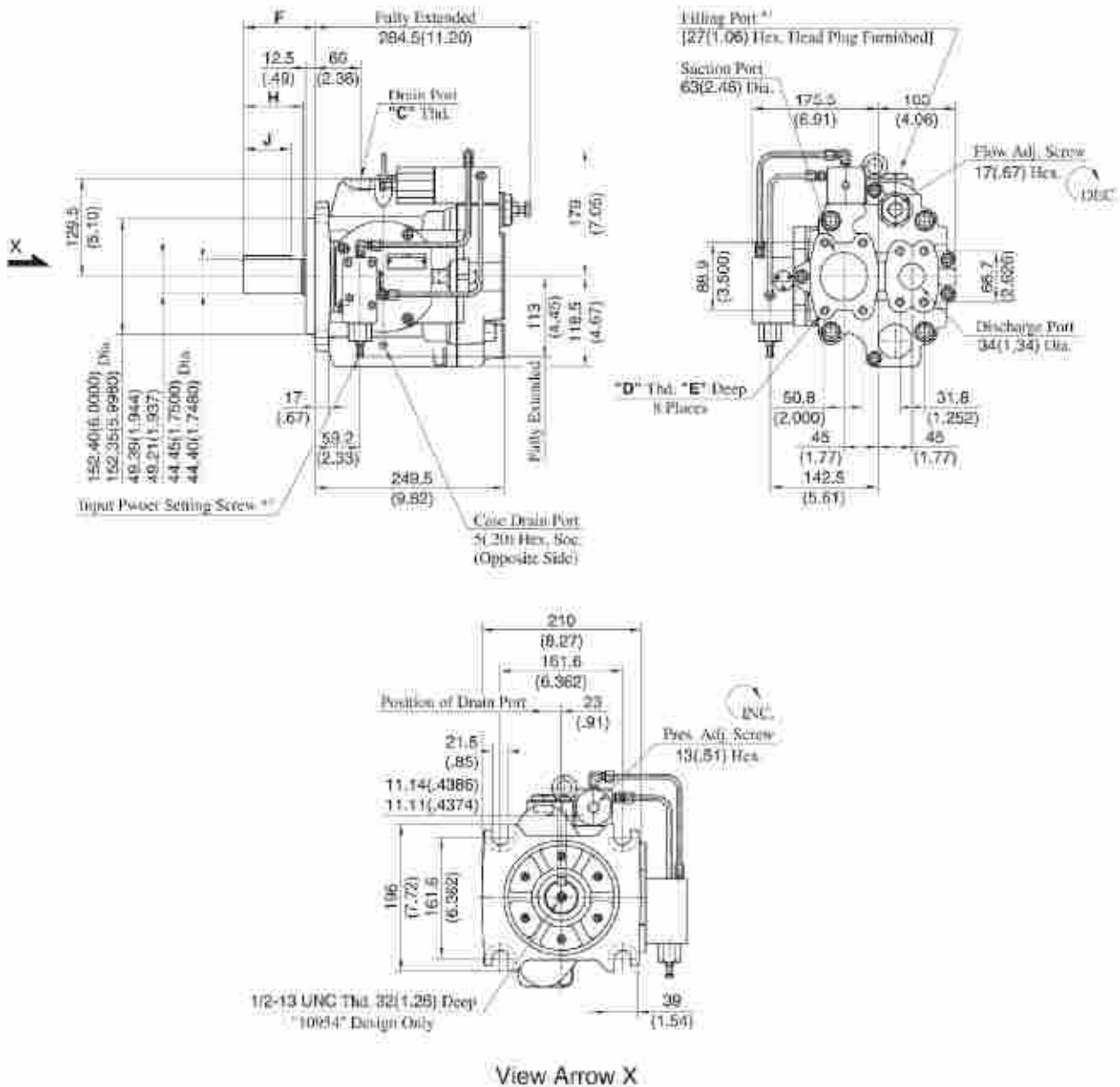

Model Numbers	Thread Size		Dimensions mm (Inches)			
	C	D	E	F	H	J
A3H100-FR09-***K-10	Rc 3/4	M12	19 (.75)	95 (3.74)	81 (3.19)	63 (2.48)
A3H100-FR09-***K-1080	3/4 BSP F					
A3H100-FR09-***K-10954	SAE #12	1/2-13 UNC	21 (.83)	74.6 (2.94)	60.6 (2.39)	50 (1.97)

- * 1. Install the pump so that the "Filling Port" is at the top.
- * 2. Do not touch the screw because it is adjusted at the time of shipment.

DIMENSIONS IN MILLIMETRES (INCHES)

● Foot Mounting Type

Mounting bracket is common to that of pressure compensator model.
 Refer to page 136 for the dimensions of mounting bracket.

Flange Mtg.: A3H145-FR09-***K*-10/1080/10954

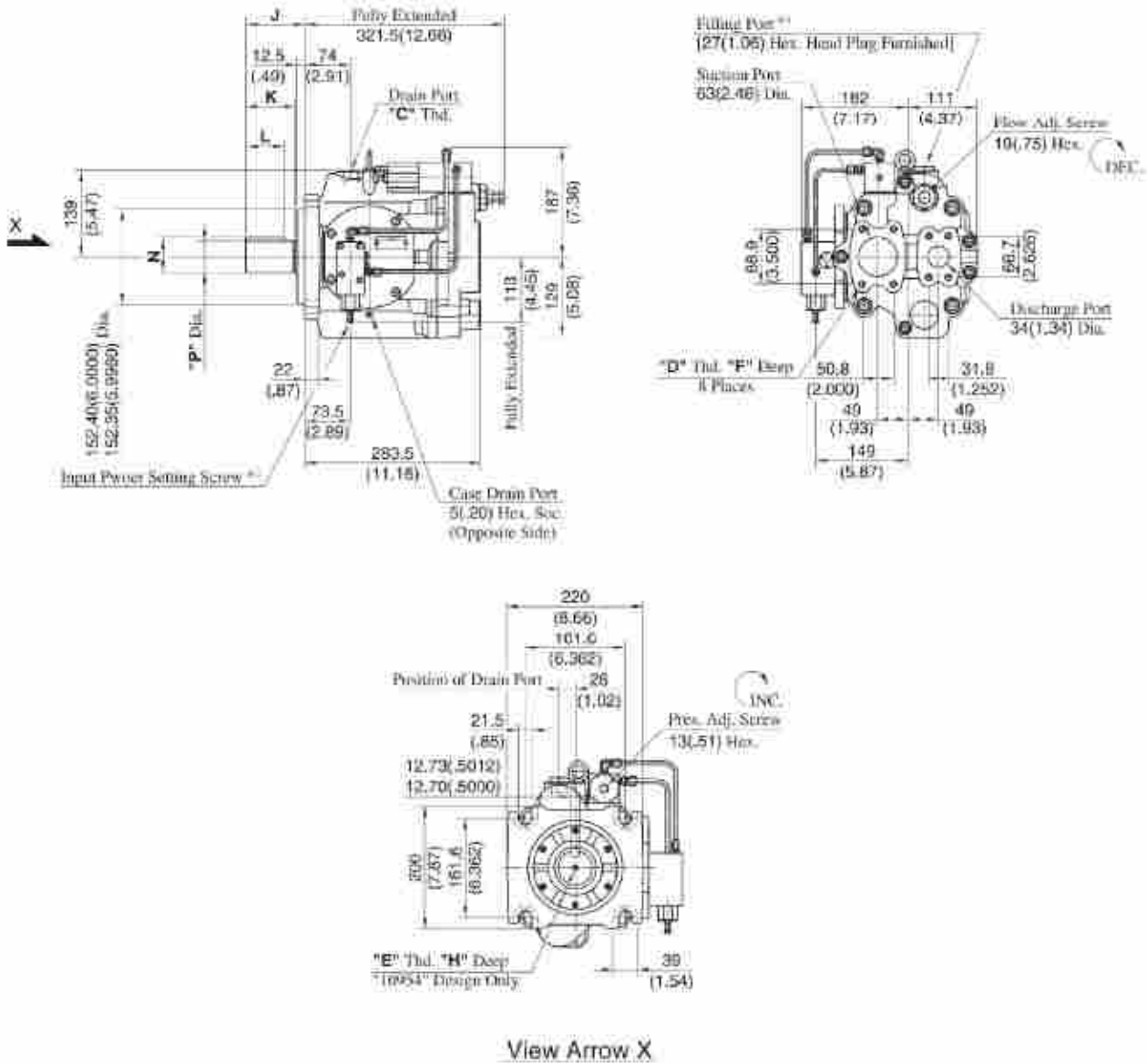

View Arrow X

Model Numbers	Thread Size		Dimensions (mm (Inches))							
	C	D	E	F	H	J	K	L	N	P
A3H145-FR09-***K-10	R _z 1/4	M12	—	19(1.75)	—	95(3.74)	81(3.19)	63(2.48)	56.43(2.222)	50.80(2.0000)
A3H145-FR09-***K-1080	3/4 BSP F								56.25(2.215)	50.75(1.9980)
A3H145-FR09-***K-10954	SAE #12	1/2-13 UNC	1/2-13 UNC	21(1.83)	32(1.26)	74.6(2.94)	60.6(2.39)	50(1.97)	49.39(1.944)	44.45(1.7500)
A3H145-FR09-***K1-10954									5/8-11 UNC	36(1.42)
									56.25(2.215)	50.75(1.9980)

- * 1. Install the pump so that the "Filling Port" is at the top.
- * 2. Do not touch the screw because it is adjusted at the time of shipment.

DIMENSIONS IN MILLIMETRES (INCHES)

● Foot Mounting Type

Mounting bracket is common to that of pressure compensator model.
 Refer to page 137 for the dimensions of mounting bracket.

Flange Mtg.: A3H180-FR09-***K*-10/1080/10954

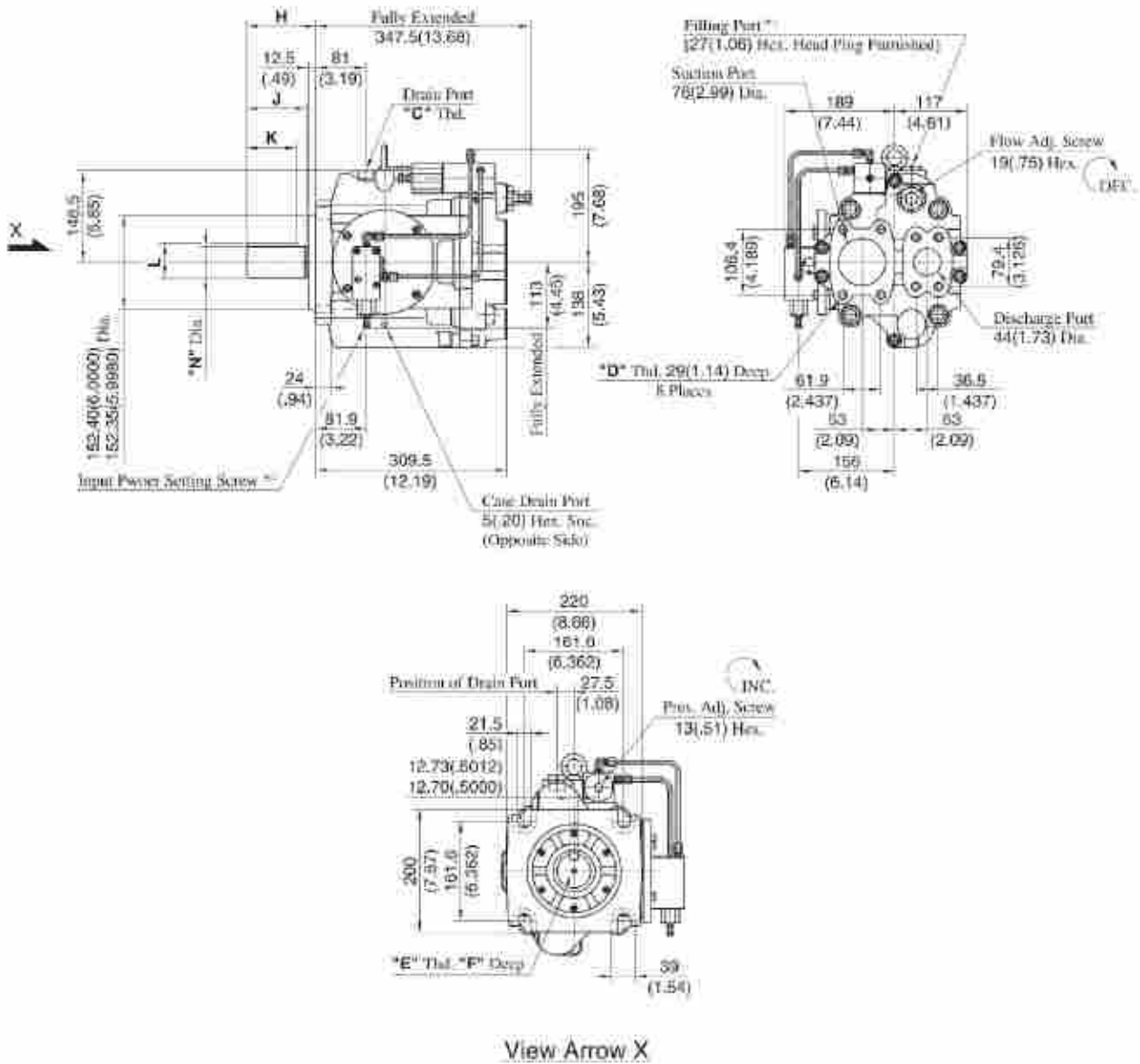

Model Numbers	Thread Size		Dimensions - mm (Inches)						
	C	D	E	F	H	J	K	L	N
A3H180-FR09-***K*-10	3/4 Rc	M16	—	—	112(4.41)	97.5(3.84)	80(3.15)	56.43(2.222)	50.80(2.0000)
A3H180-FR09-***K*-1080	3/4 BSPF							56.25(2.215)	50.75(1.9980)
A3H180-FR09-***K*-10954	SAE #12	5/8-11 UNC	1/2-13 UNC	32(1.26)	99.8(3.93)	85.3(3.36)	70(2.76)	49.39(1.944)	44.45(1.7500)
A3H180-FR09-***K*-10954			5/8-11 UNC	36(1.42)				56.43(2.222)	50.80(2.0000)
								56.25(2.215)	50.75(1.9980)

- ★ 1. Install the pump so that the "Filling Port" is at the top.
- ★ 2. Do not touch the screw because it is adjusted at the time of shipment.

DIMENSIONS IN MILLIMETRES (INCHES)

● **Foot Mounting Type**

Mounting bracket is common to that of pressure compensator model.
 Refer to page 138 for the dimensions of mounting bracket.

"A3H" Series Variable Displacement Piston Pumps-Single Pump, Load Sensing Type



Graphic Symbol



★ A flow control valve is not included with the pump. Install the valve separately.

Specifications

Model Numbers	Geometric Displacement cm ³ /rev (cu. in./rev)	Operating Pressure* MPa (PSI)		Load Sensing Pres. Difference ΔP MPa (PSI)	Shaft Speed Range r/min		Approx. Mass kg (lbs.)	
		Rated	Intermittent		Max.**	Min.	Flange Mtg.	Foot Mtg.
A3H 16-#R14K-10#	16.3 (995)	28 (4060)	35 (5080)	1.5 (218) (At the time of shipment)**	3600	600	17.5 (38.6)	26.4 (58.2)
A3H 37-#R14K-10#	37.1 (226)				2700	600	22.5 (49.6)	30.0 (66.2)
A3H 56-#R14K-10#	56.3 (344)				2500	600	28.7 (63.3)	36.2 (79.8)
A3H 71-#R14K-10#	70.7 (431)				2300	600	38.0 (83.8)	45.5 (100)
A3H100-#R14K-10#	100.5 (613)				2100	600	47.6 (105)	75.6 (167)
A3H145-#R14K-10#	145.2 (886)				1800	600	65.0 (139)	91.0 (201)
A3H180-#R14K-10#	180.7 (1103)				1800	600	73.4 (162)	101.4 (224)

- ★1. The operating pressure means pump discharge pressure.
- ★2. Load pressure difference ΔP is adjustable in range of 1.0-3.0 MPa (145-435 PSI).
- ★3. The maximum shaft speeds shown in the above table are at suction pressure 0 kPa (0 PSIG).

Model Number Designation

A3H37	-F	R	14	K	-10	*	
Series Number	Mounting	Direction of Rotation	Control Type	Shaft Extension**	Design Number	Design Std.	
A3H16 (16.3 cm ³ /rev)	F: Flange Mtg.	(Viewed from Shaft End) R: Clockwise* (Normal)	14: Load Sensing Type	K : Keyed Shaft	10	Refer to ★3	
A3H37 (37.1 cm ³ /rev)					10		
A3H56 (56.3 cm ³ /rev)	L: Foot Mtg.				10		
A3H71 (70.7 cm ³ /rev)	10						
A3H100 (100.5 cm ³ /rev)	F: Flange Mtg.				10		
A3H145 (145.2 cm ³ /rev)	L: Foot Mtg.**				K : Keyed Shaft [44.45mm (1.75 IN.) Dia.]		10
A3H180 (180.7 cm ³ /rev)					K1: Keyed Shaft** [50.8mm (2.0 IN.) Dia.]		10

- ★1. Available to supply pump with anti-clockwise rotation. Consult Yuken for details.
- ★2. We can also supply spline-type shaft extension. Consult Yuken for details.
- ★3. Design Standards: None Japanese Standard "JIS"
 80 European Design Standard
 950 N. American Design Standard (Applicable only for A3H16/37/56/71)
 954 N. American Design Standard (Applicable only for A3H100/145/180)
- ★4. Mounting type "L" is not available for N. American Design Standard.
- ★5. Shaft extension "K1" is applicable only for N. American Design Standard.



■ Pipe Flange Kits

For pipe flange, refer to form of pressure compensator type on page 123.

Typical Performance Characteristics of Control Type "A3H71" at Viscosity 32 mm²/s [ISO VG32 oils, 40°C (104°F)]

● Pressure vs. Output Flow

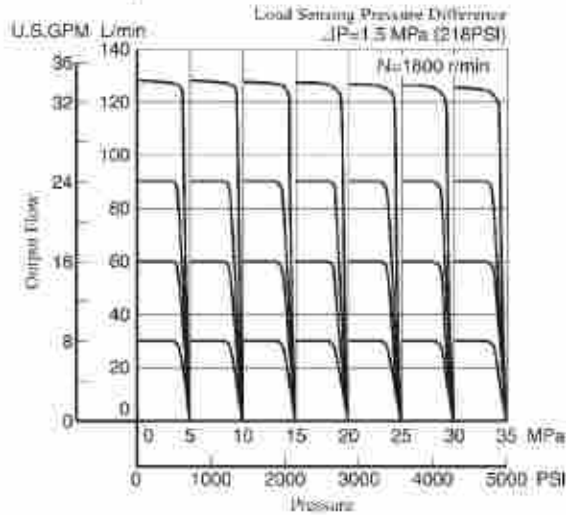

● Full Cut-off Input Power

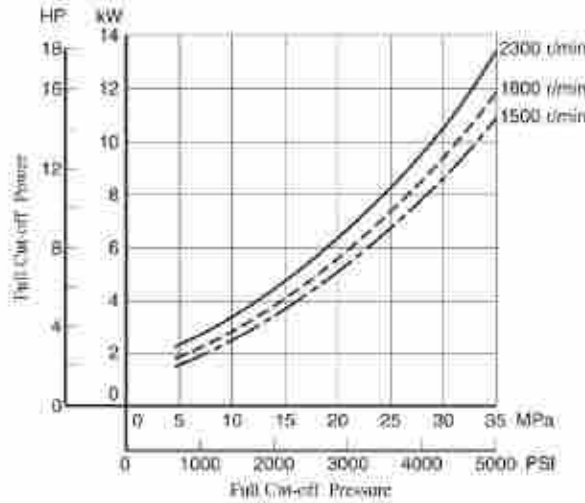

● Drain

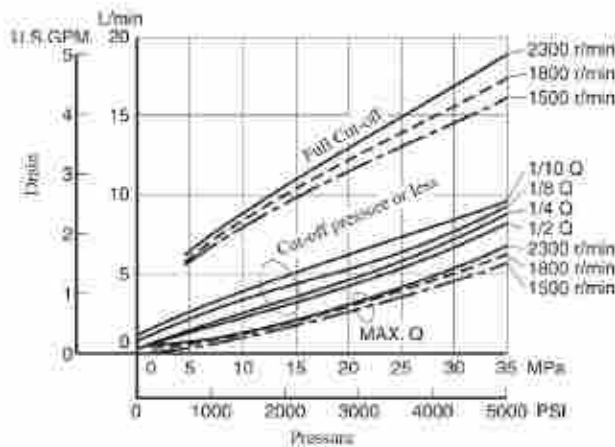

★ Ask Yazen for Performance characteristics of other series than A3H71.

Flange Mtg.: A3H16-FR14K-10/1080/10950

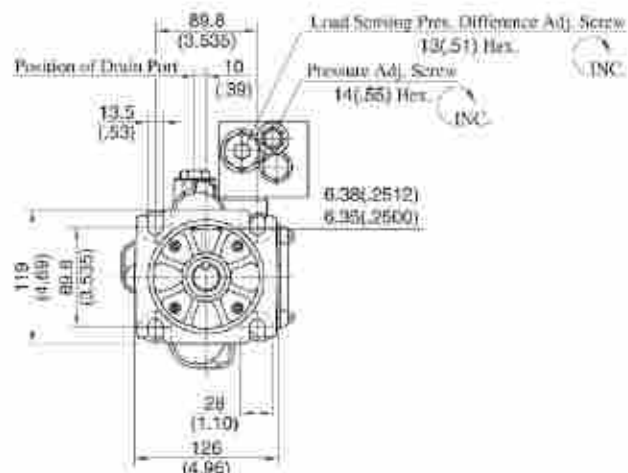
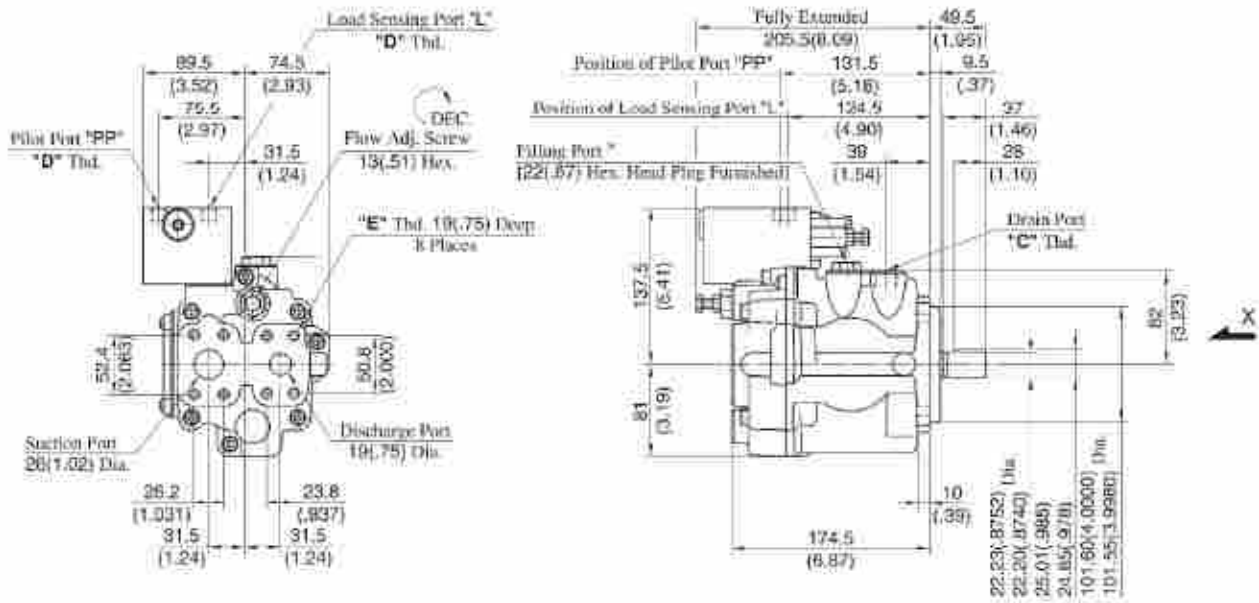

View Arrow X

Model Numbers	Thread Size		
	C	D	E
A3H16-FR14K-10	Re 1/2	Re 1/4	M10
A3H16-FR14K-1080	1/2 BSP.F	1/4 BSP.F	
A3H16-FR14K-10950	SAE #10	SAE #4	7/16-14 UNC

★ Install the pump so that the "Filling Port" is at the top.

DIMENSIONS IN MILLIMETRES (INCHES)

● Foot Mounting Type

Mounting bracket is common to that of pressure compensator model. Refer to page 132 for the dimensions of mounting bracket.

Flange Mtg.: A3H37-FR14K-10/1080/10950

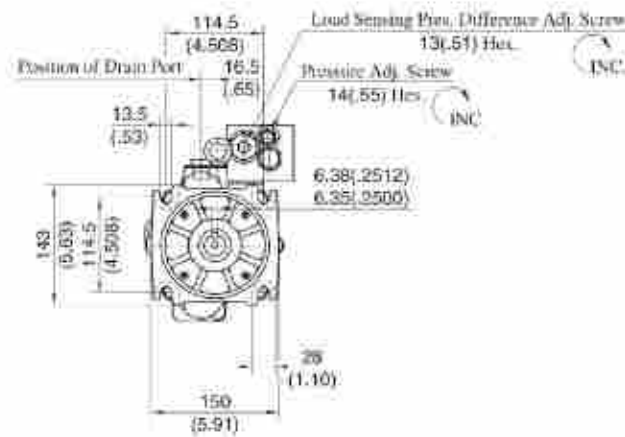
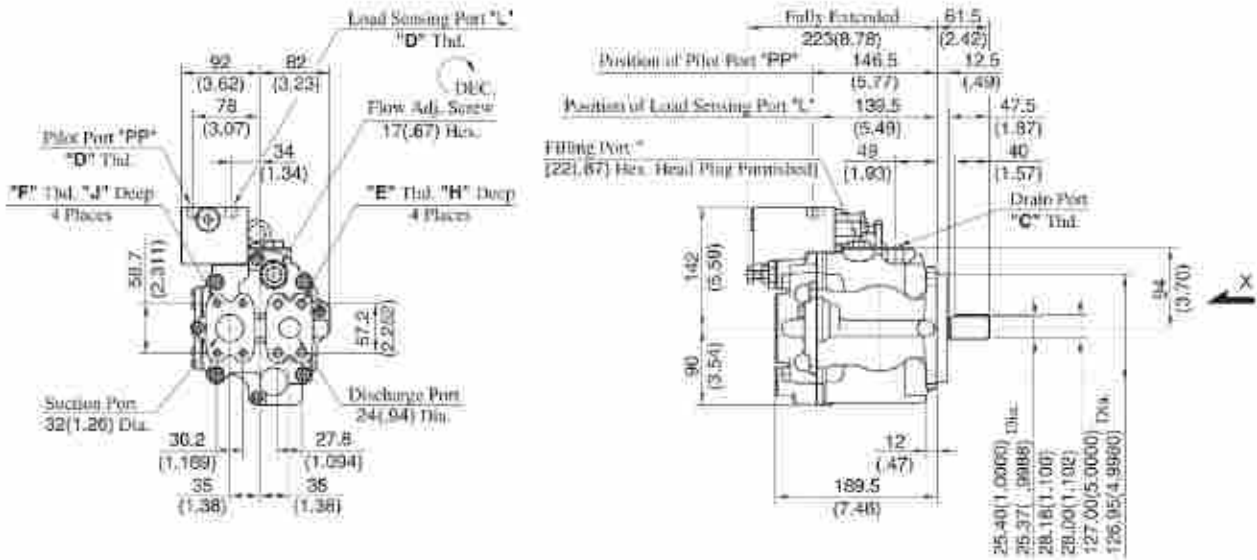

View Arrow X

Model Numbers	Thread Size				Dimensions mm (Inches)	
	C	D	E	F	H	J
A3H37-FR14K-10	Rc 1/2	Rc 1/4	M12	M10	22 (.87)	18 (.71)
A3H37-FR14K-1080	1/2 BSP.F	1/4 BSP.F				
A3H37-FR14K-10950	SAE #10	SAE #4	1/2-13 UNC	7/16-14 UNC	21 (.83)	20 (.79)

★ Install the pump so that the "Filling Port" is at the top.

DIMENSIONS IN
MILLIMETRES (INCHES)

● Foot Mounting Type

Mounting bracket is common to that of pressure compensator model.
 Refer to page 133 for the dimensions of mounting bracket.

Flange Mtg.: A3H56-FR14K-10/1080/10950

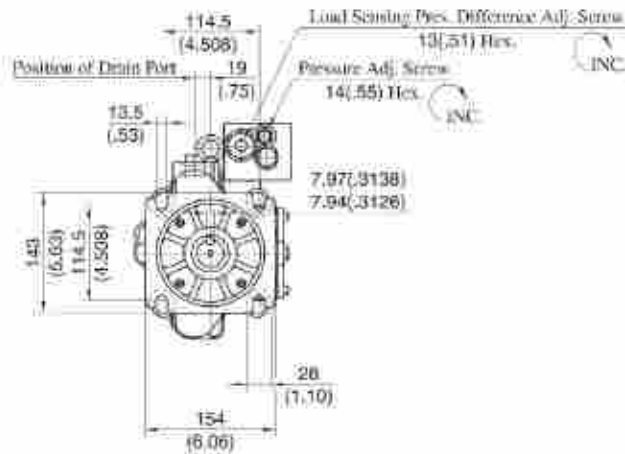
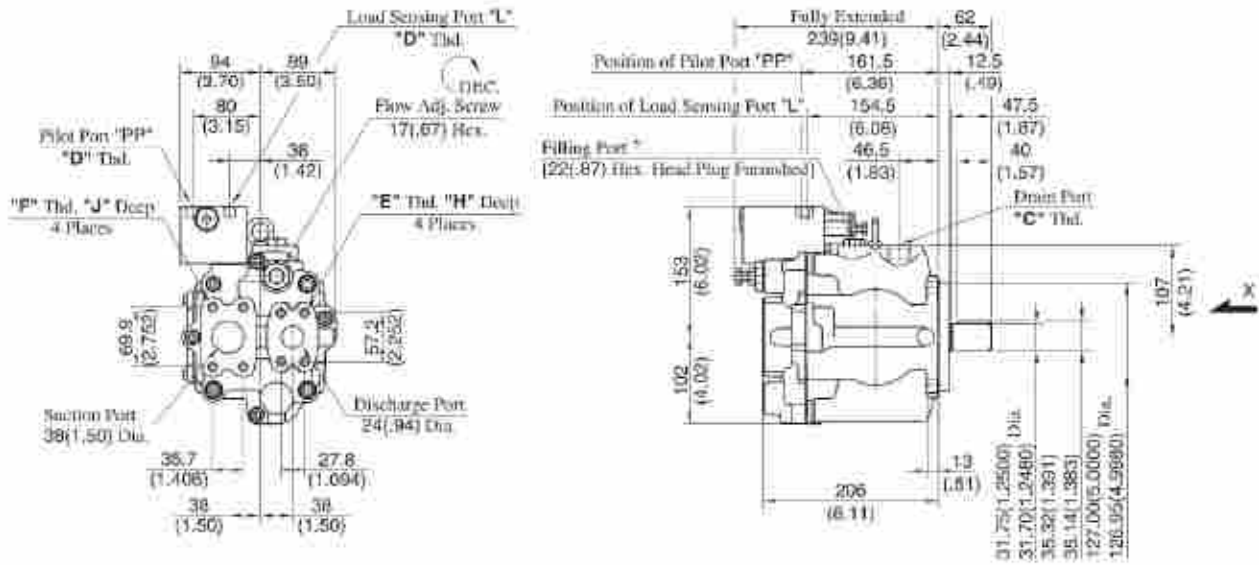

View Arrow X

Model Numbers	Thread Size				Dimensions mm (inches)	
	C	D	E	F	H	J
A3H56-FR14K-10	Rc 3/4	Rc 1/4	M12	M12	22 (.87)	22 (.87)
A3H56-FR14K-1080	3/4 BSP F	1/4 BSP F				
A3H56-FR14K-10950	SAE #12	SAE #4	1/2-13 UNC	7/16-14 UNC	21 (.83)	20 (.79)

★ Install the pump so that the "Filling Port" is at the top.

DIMENSIONS IN MILLIMETRES (INCHES)

● **Foot Mounting Type**

Mounting bracket is common to that of pressure compensator model.
 Refer to page 134 for the dimensions of mounting bracket.

Flange Mtg.: A3H71-FR14K-10/1080/10950

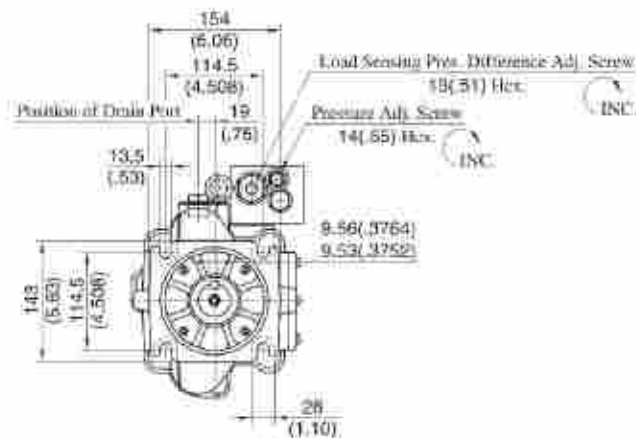
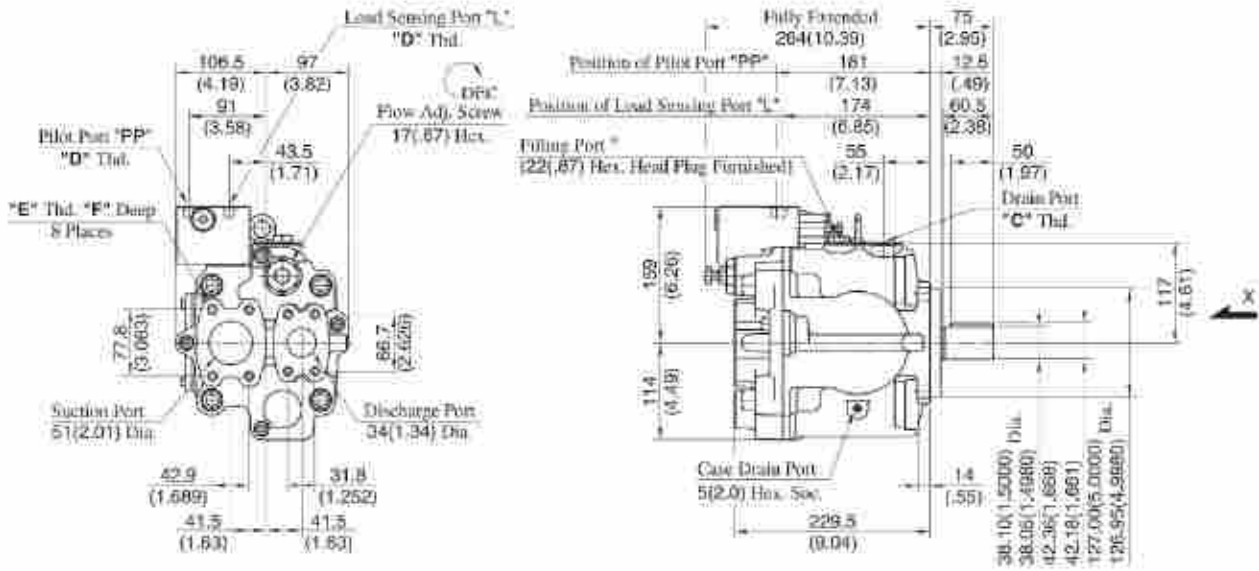

View Arrow X

Model Numbers	Thread Size			Dimensions mm (Inches)
	C	D	E	
A3H71-FR14K-10	Re 3/4	Re 1/4	M12	19 (.75)
A3H71-FR14K-1080	3/4 BSP F	1/4 BSP F		
A3H71-FR14K-10950	SAE #12	SAE #4	1/2-13 UNC	21 (.83)

* Install the pump so that the "Filling Port" is at the top.

DIMENSIONS IN
MILLIMETRES (INCHES)

● Foot Mounting Type

Mounting bracket is common to that of pressure compensator model.
 Refer to page 135 for the dimensions of mounting bracket.

Flange Mtg.: A3H100-FR14K-10/1080/10954

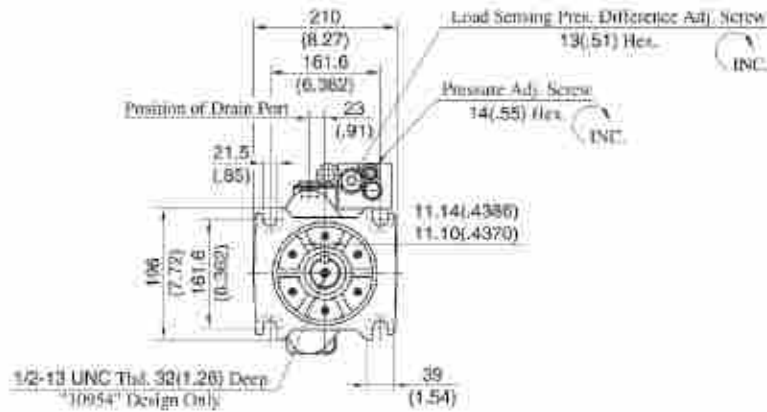
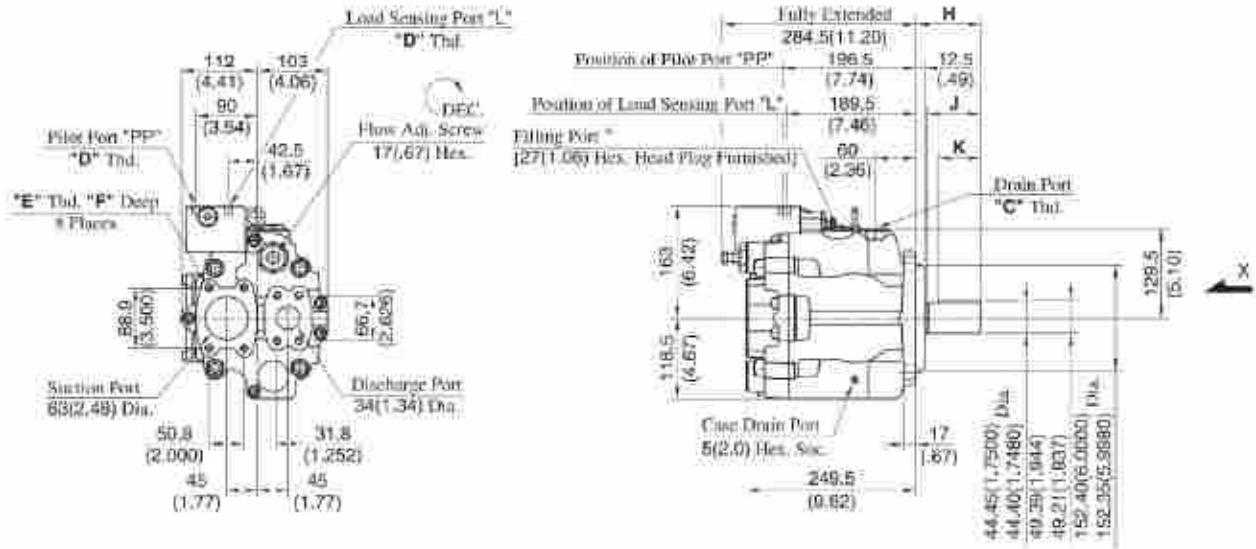

View Arrow X

Model Numbers	Thread Size			Dimensions - mm (Inches)				
	C	D	E	F	H	J	K	
A3H100-FR14K-10	R _o 3/4	R _o 1/4	M12	19 (.75)	95 (3.74)	81 (3.19)	63 (2.48)	
A3H100-FR14K-1080	3/4 BSP.F	1/4 BSP.F						
A3H100-FR14K-10954	SAE #12	SAE #1	1/2-13 L/NC	21 (.83)	74.6 (2.94)	60.6 (2.39)	50 (1.97)	

★ Install the pump so that the "Filling Port" is at the top.

DIMENSIONS IN MILLIMETRES (INCHES)

● **Foot Mounting Type**

Mounting bracket is common to that of pressure compensator model. Refer to page 136 for the dimensions of mounting brackets.

Flange Mtg.: A3H145-FR14K*-10/1080/10954

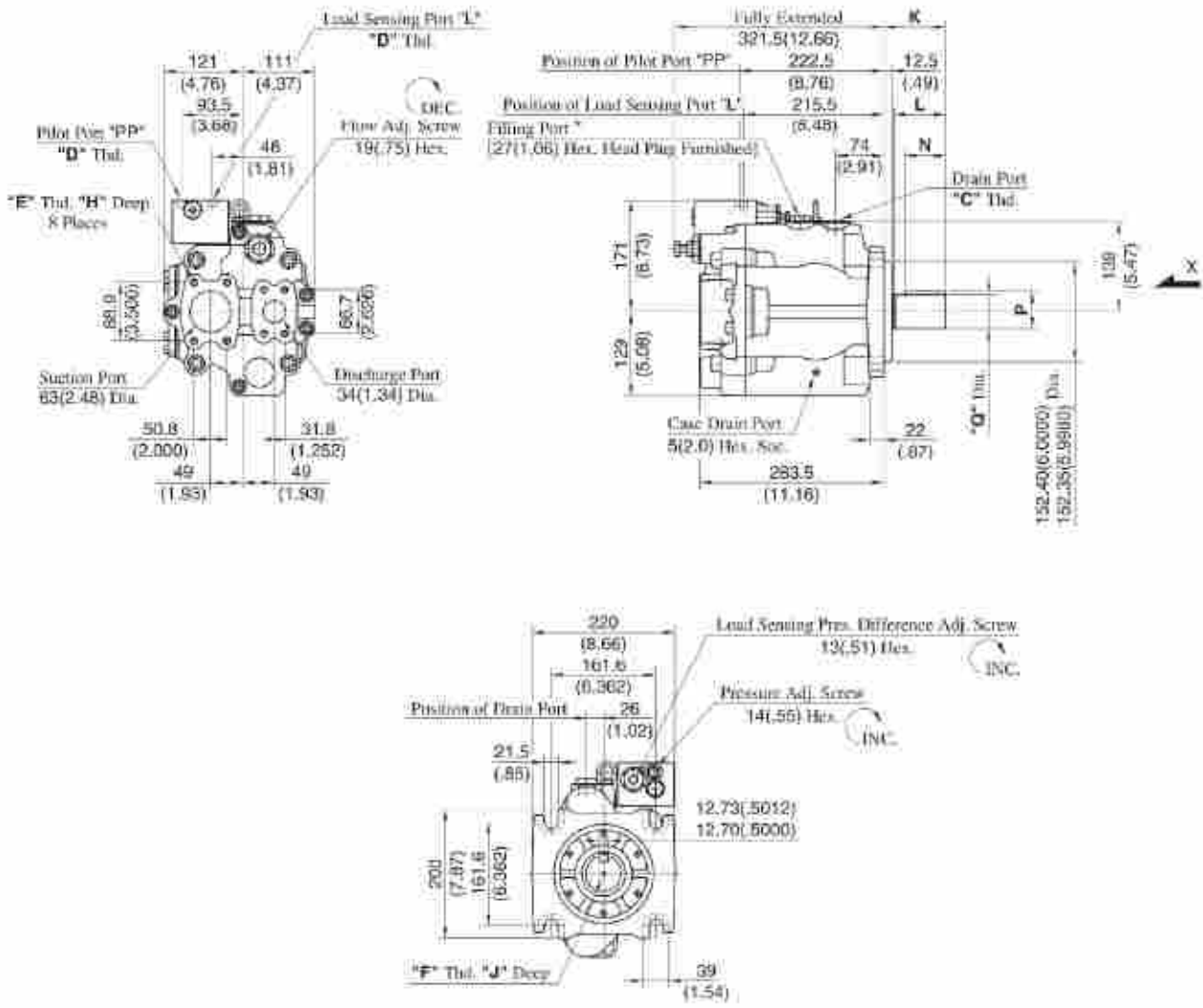

View Arrow X

Model Numbers	Thread Size				Dimensions mm (Inches)						
	C	D	E	F	H	J	K	L	N	P	Q
A3H145-FR14K-10	Re 3/4	Re 1/4	M12	—	19 (0.75)	—	95 (3.74)	81 (3.19)	63 (2.48)	56.43 (2.222)	50.80 (2.000)
A3H145-FR14K-1080	1/4 BSP F	1/4 BSP F								56.25 (2.215)	50.75 (1.998)
A3H145-FR14K-10954	SAE #12	SAE #4	1/2-13 UNC	1/2-13 UNC	21 (0.83)	32 (1.26)	74.6 (2.94)	60.6 (2.39)	50 (1.97)	49.39 (1.944)	44.45 (1.750)
										49.21 (1.937)	44.40 (1.748)
AMH145-FR14K1-10954			5/8-11 UNC	5/8-11 UNC	36 (1.42)					56.43 (2.222)	50.80 (2.000)
										56.25 (2.215)	50.75 (1.998)

★ Install the pump so that the "Filling Port" is at the top.

DIMENSIONS IN MILLIMETRES (INCHES)

● Foot Mounting Type

Mounting bracket is common to that of pressure compensator model.
 Refer to page 137 for the dimensions of mounting bracket.

Flange Mtg.: A3H180-FR14K*-10/1080/10954

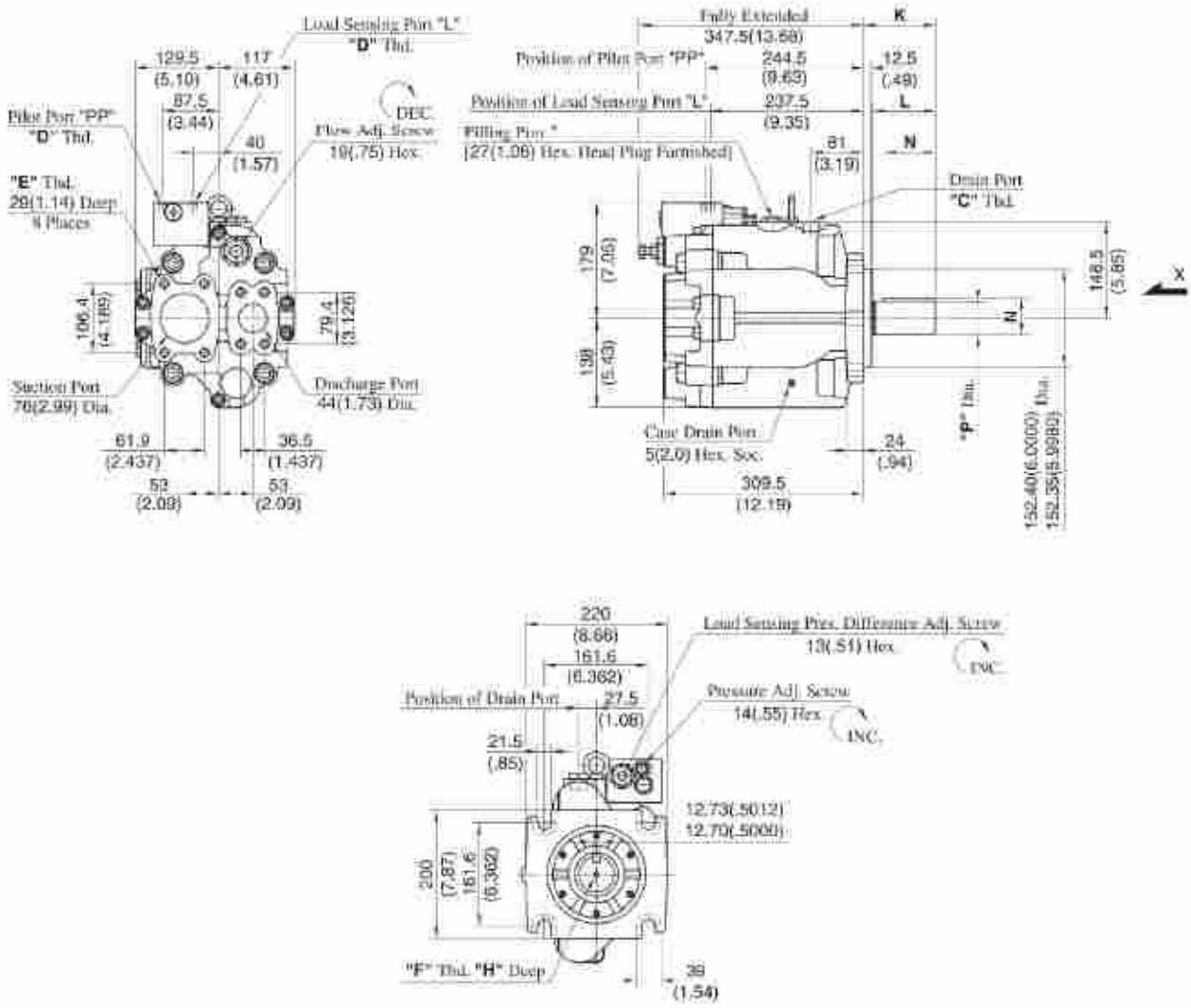

View Arrow X

Model Numbers	Thread Size			Dimensions mm (Inches)						
	C	D	E	F	H	J	K	L	N	P
A3H180-FR14K-10	Re 3/4	Re 1/4	M12	—	—	112 (4.41)	97.5 (3.84)	80 (3.15)	56.43 (2.222)	50.80 (2.0000)
A3H180-FR14K-1080	3/4 BSP.F	1/4 BSP.F							56.25 (2.215)	50.75 (1.9980)
A3H180-FR14K-10954	SAE #12	SAE #4	1/2-13 UNC	32 (1.26)	99.8 (3.93)	85.3 (3.36)	70 (2.76)	49.39 (1.944)	44.45 (1.7500)	
A3H180-FR14K1-10954			5/8-11 UNC	36 (1.42)				56.43 (2.222)	50.80 (2.0000)	
									56.25 (2.215)	50.75 (1.9980)

★ Install the pump so that the "Filling Port" is at the top.

DIMENSIONS IN MILLIMETRES (INCHES)

● **Foot Mounting Type**

Mounting bracket is common to that of pressure compensator model.
 Refer to page 138 for the dimensions of mounting brackets.