

ITALGROUP-ADVANCED-MOTORS

IAM SERIES

TECHNICAL CATALOGUE

INDEX

<u>GENERAL INFORMATION</u>	<i>Pag.</i>	2
<u>ORDERING INSTRUCTIONS</u>	"	3
<u>MOTOR TECHNICAL DATA</u>	"	4
<u>HYDRAULIC FLUIDS RECOMMENDATIONS</u>	"	7
<u>INSTRUCTIONS AND ADVICES</u>	"	8
<u>BEARINGS</u>	"	8
<u>SHAFT SEAL FEATURES</u>	"	9
<u>FLUSHING</u>	"	10
<u>DRAIN RECOMMENDATIONS</u>	"	12
<u>FORMULAS</u>	"	13
<u>CONVERSIONS</u>	"	13
<u>IAM H1 SERIES</u>	"	15 - 25
<u>IAM H2 SERIES</u>	"	27 - 39
<u>IAM H3 SERIES</u>	"	41 - 52
<u>IAM H4 SERIES</u>	"	53 - 63
<u>IAM H45 SERIES</u>	"	65 - 70
<u>IAM H5 SERIES</u>	"	71 - 80
<u>IAM H55 SERIES</u>	"	81 - 86
<u>IAM H6 SERIES</u>	"	87 - 94
<u>IAM H7 SERIES</u>	"	95 - 101
<u>IAM H8 SERIES</u>	"	103 - 109
<u>FLOW DISTRIBUTORS</u>	"	111 - 113
<u>ACCESSORIES</u>	"	115 - 135
<u>CONTACT US</u>	"	136
<u>REACH US</u>	"	136

GENERAL INFORMATION

ITALGROUP produces RADIAL PISTON HYDRAULIC MOTORS since 1985: our yearly production is more than 13.000 units which we sell all over the world through our agents and authorized sellers. Our motor range varies from 20cc to 8500cc displacement and it is completed by two-speed motors and special motors created in cooperation with our clients for different applications such as : underwater, high & low speed and wheel motors and with the possibility to assemble valves, brakes or gear reductions. You can directly contact our Technical Department which will give you all the necessary support to find the right solutions to your problems.

ITALGROUP is a flexible work reality and manages deliveries also within the same day of order; we produce motors exactly interchangeable with our competitors, always ready on stock which our clients particularly appreciate.

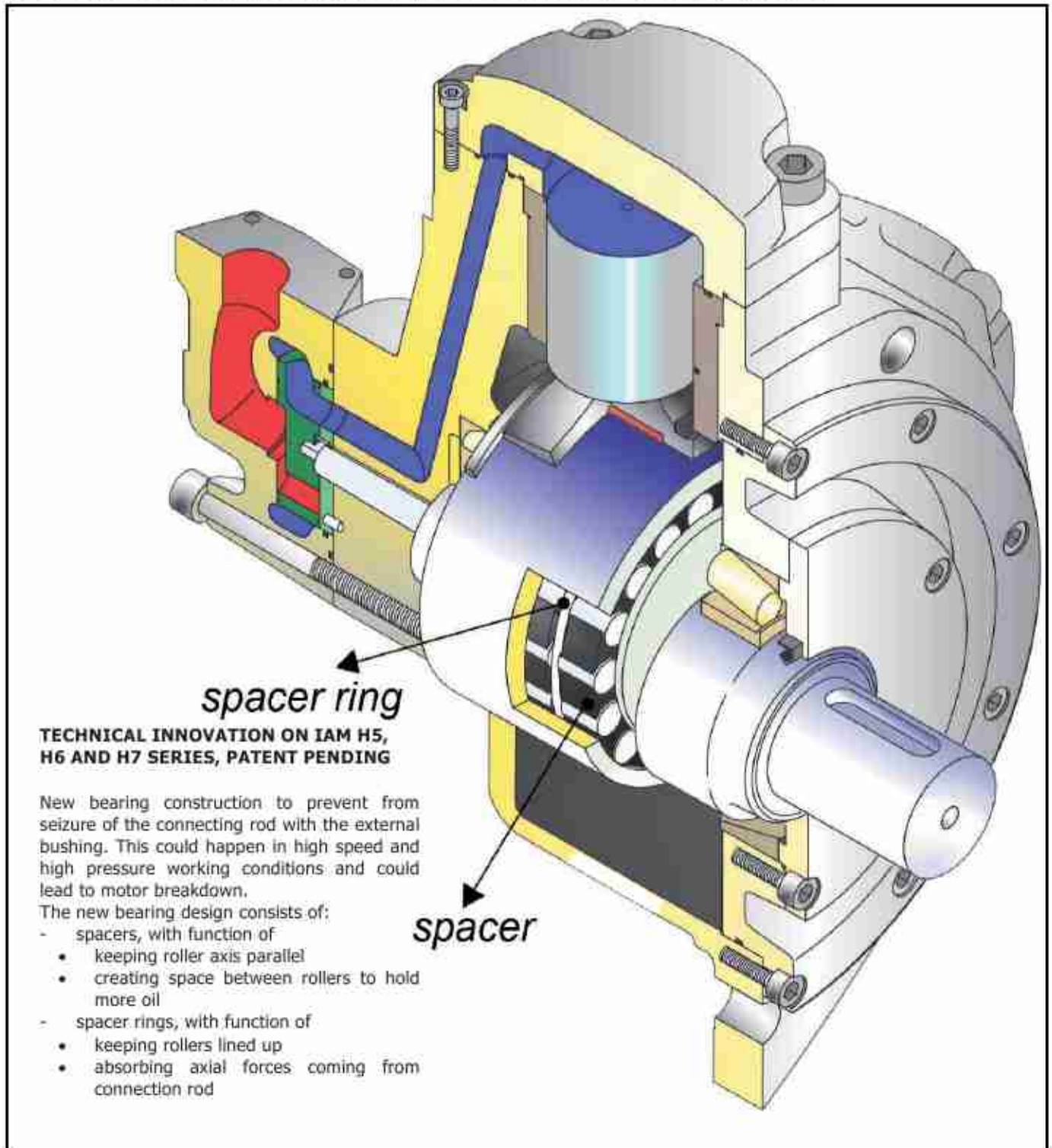

ORDERING INSTRUCTIONS

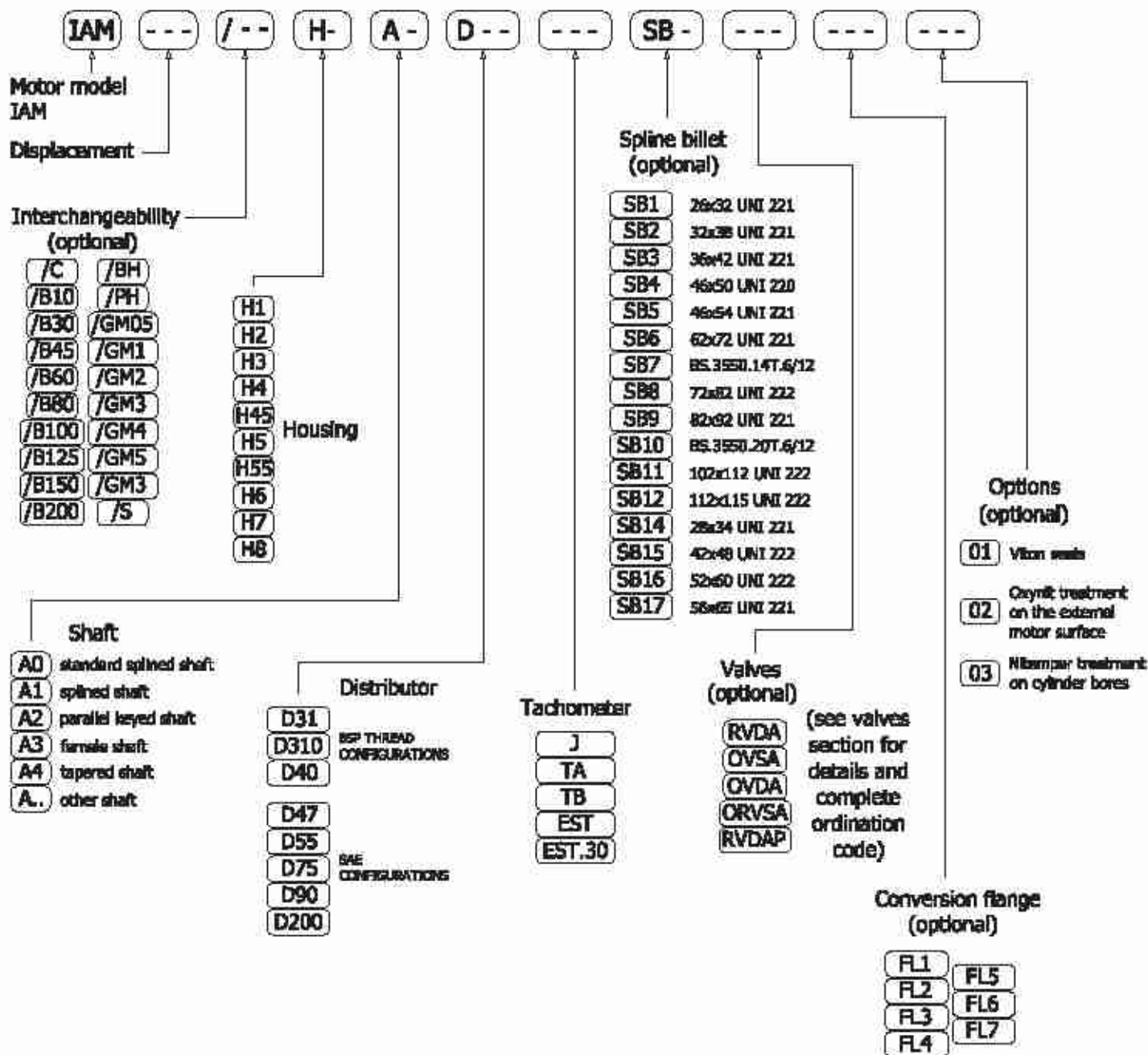

EXAMPLE: IAM.100/BH.H1.A0.D40.J.SB14
 IAM.3000.H6.A2.D90
 IAM.4300/C.H7.A0.D90.TB

For more details on available displacements or shaft options and accessories consult each section of the catalogue concerning IAM family products and accessories.

MOTOR TECHNICAL DATA

MODEL	N° of pistons	Displacement cc/rev	Specific Torque Nm/bar	Pressure			Speed		Max Case Pressure bar	Max Power		Dry Weight kg	Inertia moment of rotating parts kg cm ²	
				Max Cont.	Max Int.	Peak	Max Continuous	Peak		hp	kW			
				bar	bar	bar	rpm	rpm		bar	bar			
IAM 80	H1	5	80	1.3	250	300	350	950	1050	6	54	40	26	18
IAM 100		5	100	1.6	250	300	350	950	1050	6	54	40	26	18
IAM 150		5	157	2.5	250	300	350	950	1050	6	54	40	26	18
IAM 175		5	176	2.8	250	300	350	800	900	6	54	40	26	18
IAM 195		5	195	3.1	250	300	350	800	900	6	54	40	26	18
IAM 200		5	207	3.3	250	300	350	750	850	6	54	40	26	18
IAM 250		5	257	4.1	250	300	350	750	850	6	54	40	26	18
IAM 300		5	307	4.9	250	300	350	750	850	6	54	40	26	18
IAM 200	H2	5	198	3.2	250	300	350	800	900	6	66	49	42	27
IAM 250		5	253	4.0	250	300	350	750	850	6	66	49	42	27
IAM 300		5	314	5.0	250	300	350	750	850	6	66	49	42	27
IAM 350		5	362	5.8	250	300	350	650	750	6	66	49	42	27
IAM 400		5	424	6.7	250	300	350	600	700	6	66	49	42	27
IAM 500		5	492	7.8	250	300	350	500	600	6	66	49	42	27
IAM 600	H3	5	584	9.3	250	300	350	500	600	6	66	49	42	27
IAM 350		5	349	5.6	250	300	350	630	700	6	91	68	68	214
IAM 400		5	397	6.3	250	300	350	600	680	6	91	68	68	214
IAM 450		5	452	7.2	250	300	350	600	680	6	91	68	68	214
IAM 500		5	491	7.8	250	300	350	600	680	6	91	68	68	214
IAM 600		5	594	9.4	250	300	350	550	630	6	91	68	68	214
IAM 650		5	660	10.5	250	300	350	500	580	6	91	68	68	214
IAM 700		5	707	11.2	250	300	350	450	500	6	91	68	68	214
IAM 800	H4	5	791	12.6	250	300	350	400	450	6	91	68	68	214
IAM 700		5	714	11.4	250	300	350	500	580	6	107	80	92	267
IAM 800		5	792	12.6	250	300	350	450	530	6	107	80	92	267
IAM 850		5	847	13.5	250	300	350	450	530	6	107	80	92	267
IAM 900		5	904	14.4	250	300	350	450	530	6	107	80	92	267
IAM 1000		5	992	15.8	250	300	350	330	400	6	107	80	92	267
IAM 1100	5	1116	17.8	250	300	350	330	400	6	107	80	92	267	

MOTOR TECHNICAL DATA

MODEL	N° of pistons	Displacement cc/rev	Specific Torque Nm/bar	Pressure			Speed		Max Case Pressure bar	Max Power		Dry Weight kg	Inertia moment of rotating parts kg cm ²	
				Max Cont.	Max Int.	Peak	Max Continuous	Peak		hp	kW			
				bar	bar	bar	rpm	rpm						
IAM 1200	H4	5	1192	19.0	250	300	350	300	350	6	107	80	92	267
IAM 1250		5	1247	19.8	250	300	350	250	300	6	107	80	92	267
IAM 1400		5	1332	21.2	250	300	350	230	280	6	107	80	92	267
IAM 1100	H4S	5	1183	18.8	250	300	350	350	400	6	161	120	118	380
IAM 1400		5	1376	21.9	250	300	350	300	350	6	161	120	118	380
IAM 1600		5	1648	26.2	250	300	350	275	325	6	161	120	118	380
IAM 1800		5	1815	28.9	250	300	350	250	300	6	161	120	118	380
IAM 1000	H5	5	1094	17.4	250	300	350	350	400	6	161	120	173	697
IAM 1200		5	1231	19.6	250	300	350	300	350	6	161	120	173	697
IAM 1400		5	1376	21.9	250	300	350	300	350	6	161	120	173	697
IAM 1500		5	1528	24.3	250	300	350	300	350	6	161	120	173	697
IAM 1600		5	1648	26.2	250	300	350	300	340	6	161	120	173	697
IAM 1800		5	1815	28.9	250	300	350	250	300	6	161	120	173	697
IAM 2000		5	2035	32.4	250	300	350	230	260	6	161	120	173	697
IAM 2200		5	2220	35.3	250	300	350	220	240	6	161	120	173	697
IAM 2200	H5S	5	2126	33.8	250	300	350	240	280	6	228	170	173	837
IAM 2500		5	2525	40.2	250	300	350	240	280	6	228	170	173	837
IAM 2800		5	2807	44.7	250	300	350	240	280	6	228	170	173	837
IAM 3000		5	3028	48.2	250	300	350	230	270	6	228	170	173	837
IAM 2200	H6	5	2206	35.1	250	300	350	220	260	6	228	170	308	1745
IAM 2500		5	2525	40.2	250	300	350	220	260	6	228	170	308	1745
IAM 2800		5	2807	44.7	250	300	350	220	260	6	228	170	308	1745
IAM 3000		5	2983	47.5	250	300	350	210	250	6	228	170	308	1745
IAM 3200		5	3289	52.3	250	300	350	200	240	6	228	170	308	1745
IAM 3500		5	3479	55.4	250	300	350	200	240	6	228	170	308	1745
IAM 3900	H7	7	3907	62.2	250	300	350	160	200	6	241	180	405	4064
IAM 4300		7	4343	69.1	250	300	350	150	190	6	241	180	405	4064
IAM 4600		7	4616	73.5	250	300	350	140	190	6	241	180	405	4064

MOTOR TECHNICAL DATA

MODEL	N° of pistons	Displacement cc/rev	Specific Torque Nm/bar	Pressure			Speed		Max Case Pressure bar	Max Power		Dry Weight kg	Inertia moment of rotating parts kg cm ²	
				Max Cont.	Max Int.	Peak	Max Continuous	Peak		hp	kW			
				bar	bar	bar	rpm	rpm						
IAM 5000	H7	7	5088	81.0	250	300	350	140	180	6	241	180	405	4064
IAM 5400		7	5384	85.7	250	300	350	130	170	6	241	180	405	4064
IAM 6000	H8	10	5966	95.0	250	290	320	120	140	6	255	190	590	5380
IAM 6500		10	6581	104.7	250	290	320	120	140	6	255	190	590	5380
IAM 6800		10	6962	110.8	250	290	320	120	140	6	255	190	590	5380
IAM 7600		10	7620	121.3	190	230	280	90	100	6	241	180	590	5380
IAM 8000		10	8062	128.3	180	220	270	80	90	6	241	180	590	5380

HYDRAULIC FLUIDS RECOMMENDATIONS

HYDRAULIC FLUIDS

We recommend the use of hydraulic oils with anti-wear additives (ISO HM or HV) and minimum viscosity index of 95. Once normal working temperature is reached, oil viscosity must be at least 12 cSt, preferably in the range from 20 to 60 cSt.

Hydraulic oils meeting Denison MF-O, Vickers M-2952-S I - 286-S performance requirements and DIN 51524 specifications, are preferred.

Mineral hydraulic oils are divided into four main types, designated by the International Standards Organisation (ISO) as HH, HL, HM and HV. We advise to use only products with HM or HV specifications.

HM type

These are the most widely employed hydraulic oils. They include small quantities of anti-wear additives to provide significant improvement in wear reduction. "Superior" quality HM type oils can be used for all equipment, with the added assurance that they will be suitable for the highest temperature.

HV type

HV hydraulic oils show minimal change in viscosity with temperature variations.

OIL VISCOSITY RECOMMENDATION

Room temperature HM type ISO-VG

- 20°C / 0°C BP ENERGOL HLP - HM 22
- 15°C / +5°C BP ENERGOL HLP - HM 32
- 8°C / +15°C BP ENERGOL HLP - HM 46
- 0°C / +22°C BP ENERGOL HLP - HM 68
- +8°C / +30°C BP ENERGOL HLP - HM100
- 20°C / +5°C BP BARTRAN HV 32
- 15°C / +22°C BP BARTRAN HV 46
- 0°C / +30°C BP BARTRAN HV 68

Our motors have been designed to work also with:

- oils type ATF (Automatic Transmission Fluid)
- oils with viscosity SAE 10W - 20 -30
- multigrade motor oils SAE 10 W/40 or 15 W/40
- universal oils

During cold start-up, avoid high-speed operation until the system is warmed up to provide adequate lubrication.

Continuous working temperature must not exceed 70°C.

When the working conditions cause the oil viscosity decrease under the minimum recommended value, to guarantee a sufficient motor lubrication it is necessary an adequate motor flushing (see flushing page for more details).

FIRE RESISTANT OIL LIMITATIONS

	Max cont. pressure	Max int. pressure	Max speed
HFA, 5-95% oil-water	103	138	50%
HFB, 60-40% oil-water	138	172	100%
HFC, water-glycol	103	138	50%
HFD, ester phosphate	250	293	100%

FILTRATION

Hydraulic systems oil must always be filtered.

The choice of filtration grade derives from needs of service life and money spent. In order to obtain stated service life it is important to follow our recommendations concerning filtration grade.

When choosing the filter it is important to consider the amount of dirt particles that filter can absorb and still operate satisfactorily. For that reason we recommend filters showing when you need to substitute filtering cartridge.

- 25 µm filtration required in most applications
- 10 µm filtration in closed circuit applications

OXIDATION

Hydraulic oil oxidizes with time of use and temperature. Oxidation causes changes in colour and smell, acidity increase or sludge formation in the tank. Oxidation rate increases rapidly at surface temperatures above 60°C, in these situations oil should be checked more often.

The oxidation process increases the acidity of the fluid; the acidity is stated in terms of the "neutralization number". Oxidation is usually slow at the beginning and then it increases rapidly.

A sharp increase (by a factor of 2 to 3) in neutralization number between inspections shows that oil has oxidized too much and should be replaced immediately.

WATER CONTENT

Oil contamination by water can be detected by sampling from the bottom of the tank. Most hydraulic oils repel the water, which then collects at the bottom of the tank. This water must be drained off at regular intervals. Certain types of transmission oils and engine oils emulsify the water; this can be detected by coatings on filter cartridges or a change in the colour of the oil. In such cases, obtain your oil supplier advice.

DEGREE OF CONTAMINATION

Heavy contamination of the oil causes wear rising in hydraulic system components. Contamination causes must be immediately investigated and remedied.

ANALYSIS

It is recommended oil being analyzed every 6 months. The analysis should cover viscosity, oxidation, water content, additives and contamination. Most oil suppliers are equipped to analyze oil state and to recommend appropriate action. Oil must be immediately replaced if the analysis shows that it is exhausted.



HYDRAULIC MOTORS

ITALY

INSTRUCTIONS AND ADVICES

INSTALLATION

Hoses and piping must be clean and free from contamination. No other special requirements are necessary.

- Motor can be mounted in any position
- In run-away conditions you must use counterbalance valves
- Consult factory for intermittent applications

Splined adaptors (sleeves) are available upon request.

INSTALLATION CIRCUIT

The choice of open or closed loop circuit will be determined by the application.

Open loop circuits are cheaper and simpler to install.

Closed loop circuit is a superior circuit and usually takes up less space. It also offers better control features.

START UP

Motor case and pistons must be completely filled with oil before starting.

Do not load motor to maximum working pressure. Increase load gradually at start-up.

CASE DRAIN – CASE PRESSURE

Connect the case drain directly to tank.

The case drain port on the motor must be located on the highest point of the installation to ensure that the motor will always be full of oil. The case drain pressure must not exceed 6 bar continuous pressure.

IMPORTANT

When the motor is installed vertically with shaft pointing upwards, consult our Technical Department. If the motor is connected to high inertial loads, the hydraulic system must be designed to prevent peaks of pressure and cavitation.

TEMPERATURE

Maximum oil temperature must not exceed 70°C. Heat exchangers must be used with higher temperatures.

VISCOSITY

The motor works satisfactory in a range of 3°E to 10°E oil viscosity. Best performance is obtained at the highest viscosity.

BACK PRESSURE

Don't exceed 70 bar back pressure.

HIGH PEAKS APPLICATIONS

In case of high pressure peaks applications, a Nitemper treatment on cylinders is suggested to increase wear and tear resistance.

CONTINUOUS HIGH SPEED DUTY

In case of continuous high speed duty, it is suggested to mount a central reinforced bearing on motor shaft, please contact our Technical Department.

MINIMUM SPEED

Standard minimum speed is about 0.5 to 3 rpm (depending on motor displacement). If you need less speed, it is possible to modify some parts of the distributor.

FLUSHING

In the need of Flushing, a 2nd drain hole is available upon request. When flushing is not available, it is possible to create an inner motor drain to help cooling.

COOLING FLOW

If the motor operates in the Intermittent Power zone, it may require a cooling flow of 20 l/min (5 gpm) to keep a drain flow viscosity of 40 cSt minimum.

FOR MORE DETAILS ON THE ABOVE MENTIONED ARGUMENTS AND FOR ANY FURTHER INFORMATION PLEASE CONTACT OUR TECHNICAL DEPARTMENT.

BEARINGS

Bearings lifetime depends on the type of bearing, on motor speed and on working loads.

Lifetime is measured by L_{10} which is called "theoretic lifetime". It represents the number of cycles that 90% of identical bearings can effort at the same load without showing wear and tear. It is calculated by the following equation:

$$L_{10} = \left(\frac{C}{P}\right)^p$$

where: C = theoretical dynamic coefficient (depending on the bearing size)

P = radial load

p = exponent (p=3 for ball bearings,
p=10/3 for roller bearings)

When you work at constant speed, you can calculate the lifetime in hours with the following equation:

$$L_{10h} = \frac{10^6 \cdot L_{10}}{60 \cdot \text{rpm}} = \frac{10^6}{60 \cdot \text{rpm}} \left(\frac{C}{P}\right)^p \text{ [h]}$$

When you don't have only radial or axial loads, you have to calculate an equivalent load:

$$P = X \cdot F_R + Y \cdot F_A$$

Where

F_R = radial load,

X = radial coefficient,

F_A = axial load,

Y = axial coefficient

While F_R and F_A come from working conditions (i.e. torque),

X and Y depend on the type of bearing and on the ratio $\frac{F_A}{F_R}$.

To help you in the expected lifetime calculation, Italgroup provides you with an EXCEL calculation sheet. With this instrument you can easily calculate lifetime: you only need to choose the motor model, put speed, pressure and loads.

For further information or to have the calculation sheet, please contact our Technical Department.

SHAFT SEAL FEATURES

Type: BABSL
 Form: AS DIN 3760
 Material: SIMRIT® 72 NBR 902
 SIMRIT® 75 FKM 595

1. Features

SIMMERRING® radial shaft seal with rubber covered O.D., short, flexibility suspended, spring loaded sealing lip and additional dust lip: see Part B/ SIMMERRING®, sections 1.1 and 2.

2. Material

Sealing lip and O.D.:

- Acrylonitrile-butadiene rubber with 72 Shore

A hardness (designation: SIMRIT® 72 NBR 902)

- Fluoro rubber with 75 Shore A hardness (designation: SIMRIT®75 FKM 595)

Metal insert:

- Plain steel DIN 1624

Spring:

- Spring steel DIN 17223

3. Application

For sealing pressurised media without additional back-up ring, e. g. for rotational pressure sealing in hydraulic pumps, hydraulic motors, hydrodynamic clutches. Rubber covered O.D. assures sealing in the housing bore even in case of considerable surface roughness, thermal expansion or split housing.

Particularly suitable for sealing low viscosity and gaseous media.

Where high thermal stability and chemical resistance are required, SIMRIT® 75 FKM 595 material should be used. Additional dust lip to avoid the entry of light and medium dust and dirt.

4. Operating conditions

See Part B/ SIMMERRING®, sections 2, 4.

Media: mineral oils, synthetic oils

Temperature: -40°C to +100°C (SIMRIT® 72 NBR 902)

-40°C to +160°C (SIMRIT® 75 FKM 595)

Surface speed: up to 5 m/s

Working pressure: see diagram 1

Maximum permitted values, depending on other operating conditions.

5. Housing and Machining Criteria

See Part B/ SIMMERRING®, sections 2.

Shaft:	Tolerance:	ISO h11
	Concentricity:	IT 8
	Roughness:	Ra=0.2-0.8 µm Rz=1-4 µm Rmax=6 µm
	Hardness:	45-60 HRc
	Roughness:	non oriented;
	preferably by	plunge grinding
Housing:	Tolerance:	ISO H8
	Roughness:	Rmax < 25 µm

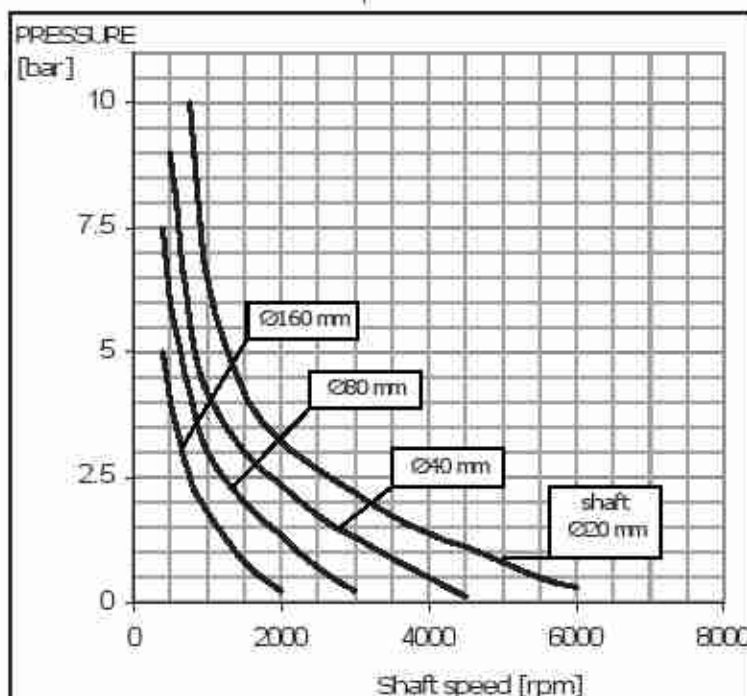

Diagram 1: Pressure Loading Limits

FLUSHING

FLUSHING FLOW

Cooling flow is necessary to assure the minimum oil viscosity. The following table shows the flushing flow approximate values that are suggested for IAM motors. In all the cases, the flushing flow must be adequate to assure the minimum oil viscosity (see page 7): therefore the flushing flow will depend by the motor displacement, working conditions and oil type, and must be set making some oil drain temperature monitoring.

Motor	Flushing flow [l/min]
IAM H1 80, 100	5
IAM H1 150, 175, 195, 200, 250, 300	6
IAM H2 200, 250, 300	
IAM H2 350, 400, 500	8
IAM H3 350, 400, 450, 500	
IAM H2 600	
IAM H3 600, 650, 700, 800	
IAM H4 700, 800, 850, 900, 1000, 1100	10
IAM H4 1200, 1250, 1400	
IAM H5 1000, 1200, 1400, 1600, 1800, 2000	
IAM H5 2200	
IAM H6 2500, 2800, 3000, 3200, 3500	15
IAM H7 3900, 4300, 4600, 5000, 5400	
IAM H8 6500, 6800, 7600, 8000, 8500	20

FLUSHING IN PERFORMANCE DIAGRAMS

Each performance diagram shows working conditions where flushing is suggested (areas numbered from 4 to 6 in each performance diagram).

Area 1: Continuous operation

Area 2: Intermittent operation for period 3-5 minute every 10-15 minute

Area 3: Intermittent operation for very short period (3-5 seconds every 10-15 minutes)

Area 4: Continuous operation with flushing

Area 5: Intermittent operation for period 3-5 minute every 10-15 minute with flushing

Area 6: Intermittent operation for very short period (3-5 seconds every 10-15 minutes) with flushing

HIGH VOLUMETRIC EFFICIENCY MOTORS

On radial piston hydraulic motors with high volumetric efficiency, and therefore Italgroup IAM series, there can be a phenomenon of oil-overheating in the body motor.

Oil drawing from the piston and from the distributor goes into body motor. When this oil quantity is very scanty, it means there's a good volumetric efficiency.

In some cases this is positive, like for winch on crane truck or trawl winch, because high volumetric efficiency avoids motor rotation even under external stress.

This scanty quantity of oil is not a problem because the motor works at high pressure only for a short period of time.

In other cases, this high efficiency can cause problems on the motor because oil exchange is missing.

In fixed applications, for example, where the motor is running constantly for 8 or more hours a day (like injection machines for plastic materials, press, bending machines, etc.) high volumetric efficiency can create temperature increasing in motor body.

In this case temperature increasing is to be avoided with the use of flushing.

Flushing consists in carrying fresh oil (taken from hydraulic circuit) in the body motor.

Oil is usually taken from return line to avoid any loss of efficiency.

In this way, all internal parts of the motor are protected with this lubrication and cooled with fresh oil, so that total efficiency is optimised.

FLUSHING CIRCUIT (ONE DIRECTION WORKING)

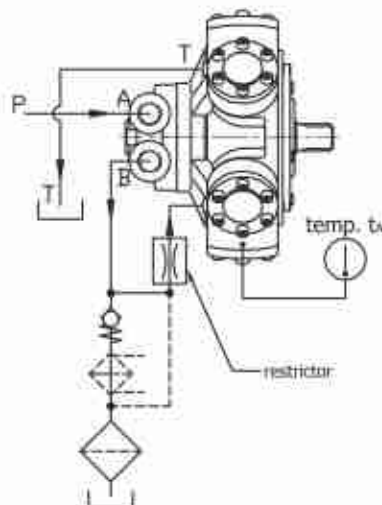

FLUSHING CIRCUIT (BIDIRECTIONAL WORKING)

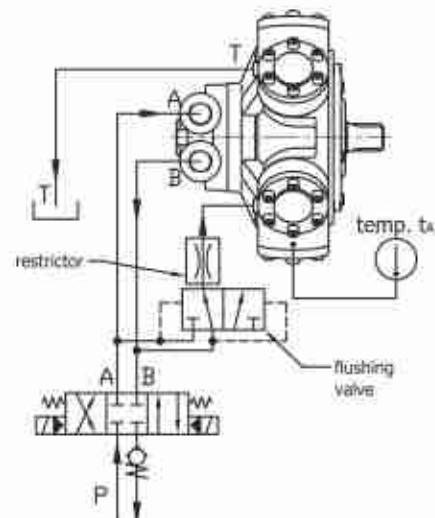

For further information please contact Italgroup technical department

Motor flushing circuit example for unidirectional working

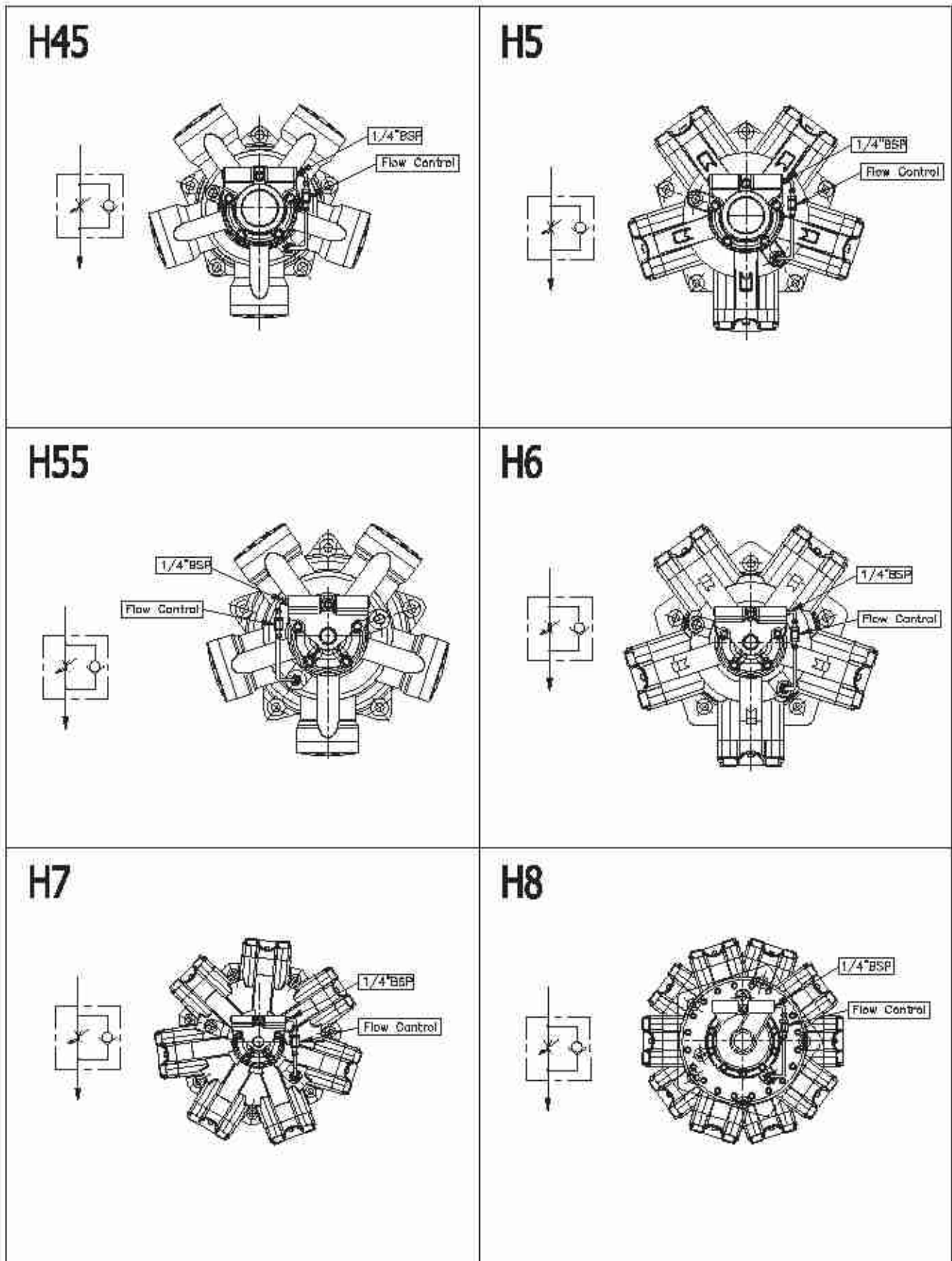

DRAIN RECOMMENDATIONS

Motor axis horizontal

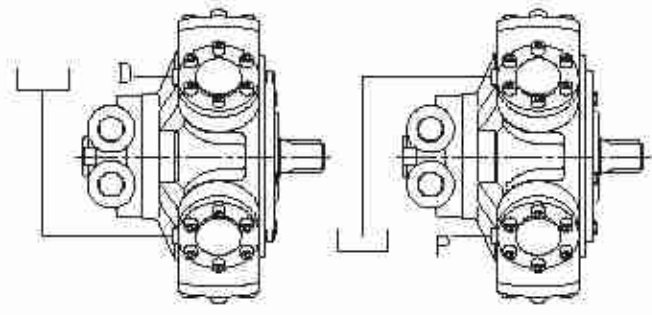

Axis vertical, shaft up

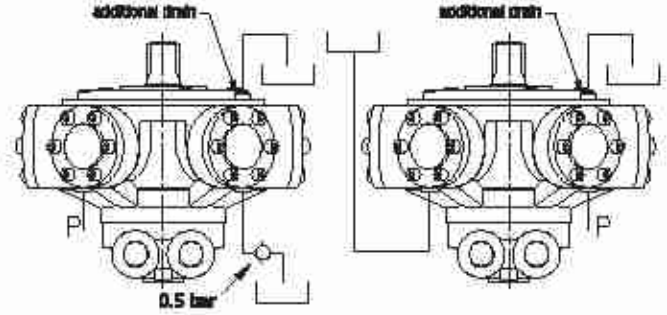

Axis vertical, shaft down

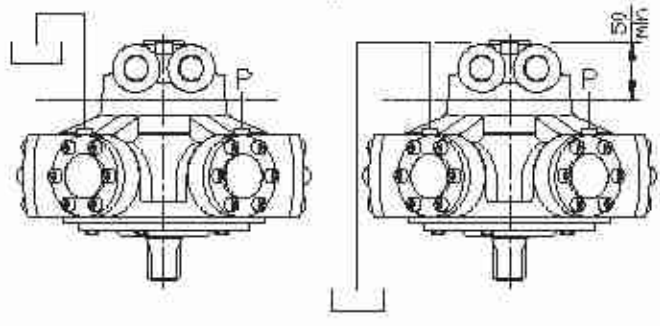

P=plug D=drain

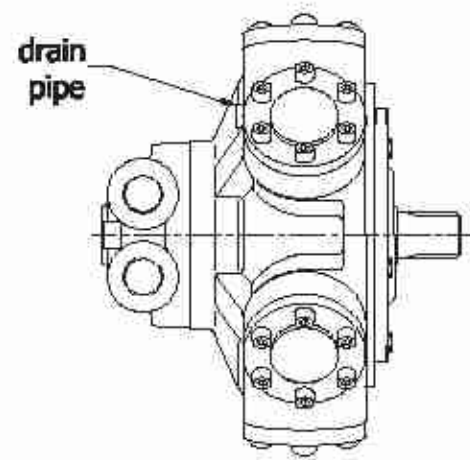

IMPORTANT

For all motors IAM series, it is necessary TO **FILL** the motor case with hydraulic fluid, through the drain pipe, before start-up.

DISTRIBUTORS PRESSURE – FLOW

		D31/D310 (IAM H1, H2, H3, H4)	D40/D47 (IAM H1, H2, H3, H4, H45)	D55 (IAM H5, H45)	D75 (IAM H5, H45, H55)	D90 (IAM H55, H6, IAMH7)	D200 (IAM H8)
Pressure bar	Continuous	250	250	250	250	250	250
	Max	500	500	400	500	500	500
Flow L/min	Continuous	200	200	300	500	600	1000
	Max	400	400	600	1000	1200	2000

FORMULAS

• TORQUE (1)	Torque = (specific torque) · (pressure)
• TORQUE (2)	$\text{Torque [Nm]} = \frac{\text{displacement [cc/rev]} \cdot \text{pressure [bar]}}{62.8}$
• POWER (1)	$\text{Power [kW]} = \frac{\text{Torque [Nm]} \cdot \text{speed [rpm]}}{9549}$
• POWER (2)	$\text{Power [CV]} = \frac{\text{Torque [Nm]} \cdot \text{speed [rpm]}}{7023}$
• SPEED	$\text{speed [rpm]} = \frac{\text{flow rate [l/min]} \cdot 1000}{\text{displacement [cc/rev]}}$
• REQUIRED MOTOR DISPLACEMENT	$\text{displacement [cc/rev]} = \frac{\text{max required torque [Nm]} \cdot 62.8}{\text{max pressure [bar]}}$
• REQUIRED PUMP FLOW RATE	$\text{flow [l/min]} = \frac{\text{displacement [cc/rev]} \cdot \text{max speed [rpm]}}{1000}$

CONVERSIONS

LENGTH	1 m = 39.3701 in = 3.2808 ft = 1.0936 yd = 1000 mm	1 lbf = 0.4536 kgf = 4.448 N
	1 in = 0.0833 ft = 25.4 mm	PRESSURE
	1 ft = 0.3048 m = 0.3333 yd = 12 in	1 bar = 14.223 psi = 0.99 atm = 1.02 ata = 100000 Pa = 100 kPa = 0.1 MPa
	1 yd = 0.9144 m = 3 ft = 36 in	1 psi = 0.0703 bar
	1 km = 1000 m = 1093.6 yd = 0.6214 mile	FLOW
	1 mile = 1.609 km = 1760 yd	1 l/min = 0.264 gpm = 1000 cc/min
MASS	1 kg = 2.2046 lb 1 lb = 0.4536 kg	1 gpm = 3.785 l/min = 3785 cc/min
SPEED	1 m/s = 3.6 km/h = 2.237 mph = 3.2808 ft/s	1 m ³ /s = 60000 l/min = 15852 gpm
	1 km/h = 0.2778 m/s = 0.6214 mph = 0.9113 ft/s	VOLUME
	1 mph = 1.609 km/h = 0.447 m/s = 1.467 ft/s	1 m ³ = 1000 l 1 l = 61.023 in ³ = 0.264 galUS
	1 ft/s = 0.3048 m/s = 1.0973 km/h = 0.6818 mph	1 in ³ = 0.01639 l = 0.004326 galUS
FORCE	1 N = 0.102 kgf = 0.2248 lbf	1 galUS = 3.7879 l = 231.15 in ³
	1 kgf = 2.205 lbf = 9.806 N	POWER
		1 kW = 1.341 HP = 1.3596 CV
		1 HP = 0.7457 kW = 1.0139 CV
		TORQUE
		1 Nm = 0.102 kgm = 0.7376 lbf ft
		1 kgm = 9.806 Nm = 7.2325 lbf ft
		1 lbf ft = 0.1383 kgm = 1.3558 Nm