

## "PV2R4A" Series Single Vane Pumps

These high pressure, high performance pumps have been developed to meet space-saving requirements. These pumps are a very compact version of the PV2R4, a vane pump series that has proven to exhibit outstanding low noise characteristics.

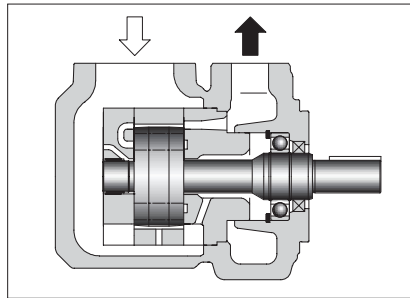

Graphic Symbol

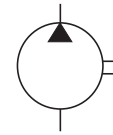

### Specifications

Model Numbers	Geometric Displacement cm <sup>3</sup> /rev (cu.in./rev)	Max. Operating Pressure MPa (PSI)						Output Flow & Input Power	Shaft Speed Range r/min	
		Petroleum Base Oils		Water Containing Fluids			Synthetic Fluids		Max.	Min.
		Anti-Wear Type	R & O Type	Anti-Wear Type Water-Glycols <sup>★1</sup>	Water Glycols	Water in Oil Emulsions	Phosphate Esters			
PV2R4A-138	138.5 (8.45)	17.2 (2500)	14 (2030)	16 (2320)	7 (1020)	7 (1020)	14 (2030)	Refer to Pages 179 & 180	1800 (1200) <sup>★3</sup>	600
PV2R4A-162	162.6 (9.92)								1800 <sup>★2</sup> (1200) <sup>★3</sup>	
PV2R4A-193	194.4 (11.86)									

★1. For the brands of anti-wear type water-glycols, see the item of "Hydraulic Fluids" on page 160.

★2. If PV2R4A-193 is used at speed above 1700 r/min, the suction pressure is limited to 0 kPa (0 in. Hg.).

★3. If phosphate ester or water containing fluids are used, the maximum speed is limited to 1200 r/min.

### Model Number Designation

F-	PV2R4A	-138	-L	-R	A	A	-10	-*	
Special Seals	Series Number	Nominal Displacement cm <sup>3</sup> /rev	Type of Mounting	Shaft Rotation	Discharge Port Position	Suction Port Position	Design Number	Design Standards	
<b>F:</b> For phosphate ester type fluids (Omit if not required)	<b>PV2R4A</b>	<b>138, 162, 193</b>	<b>L:</b> Foot Mounting <b>F:</b> Flange Mounting	<b>R:</b> Clockwise <sup>★1</sup> (Normal)	(Viewed from Shaft End) <b>A:</b> Upwards (Normal)		<b>A:</b> Upwards (Normal)	<b>10</b>	Refer to ★2

★1. Available to supply pump with anti-clockwise rotation. Consult Yuken for details.

★2. Design Standards: None.....Japanese Standard "JIS"  
 80.....European Design Standard  
 90.....N. American Design Standard

### Pipe Flange Kits

Pipe flange kits are available. When ordering, specify the kit number from the table below.

Pump Model Numbers	Name of Port	Pipe Flange Kit Numbers						
		Threaded Connection			Socket Welding <sup>★1</sup>		Butt Welding	
		Japanese Standard "JIS"	European Design Standard	N. American Design Standard <sup>★2</sup>	Japanese Standard "JIS" European Design Standard	N. American Design Standard <sup>★2</sup>	Japanese Standard "JIS" European Design Standard	N. American Design Standard <sup>★2</sup>
PV2R4A	Suction	F5-24-A-10	—	—	F5-24-B-10	F5-24-B-1090	F5-24-C-10	F5-24-C-1090
	Discharge	F5-12-A-10	F5-12-A-1080	—	F5-12-B-10	F5-12-B-1090	F5-12-C-10	F5-12-C-1090

★1. In case of using socket welding flanges, there is a case where the operating pressure should be set lower than the normal because of strength of the flanges. Therefore, please pay cautious attention to the operating pressure when the socket welding flanges are used.

★2. As dimensions of the pipe flange mounting surface are conformed to SAE 4 Bolt Split Flange (Standard Pressure Series), pipe flanges conforming to the SAE Standards can be used.

Notes: Special seals (Viton seals) are required when phosphate ester type fluids are used. (Prefix "F-" to the pipe flange kit number when ordering.)

● Details of the pipe flange kits are shown on page 824.



Flange Mtg.: PV2R4A-\*-F-RAA-10/1090

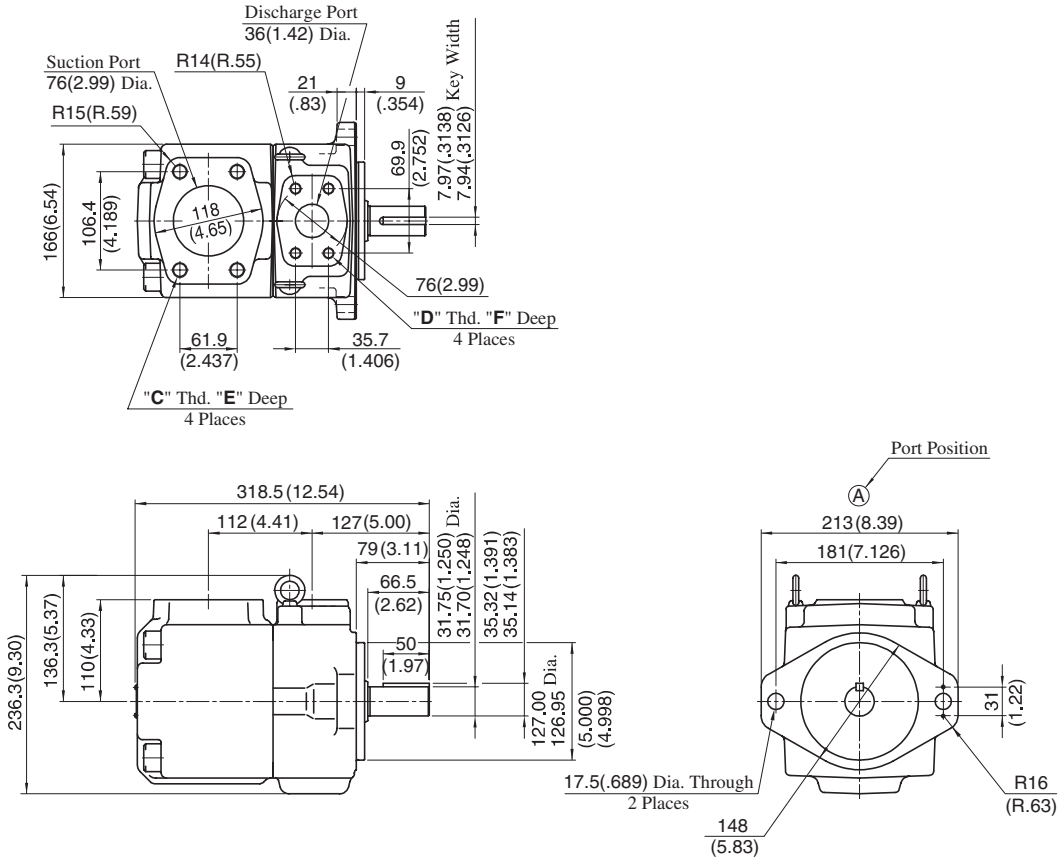

Approx. Mass.....40 kg (88.2 lbs.)

Model Numbers	"C" Thd.	"D" Thd.	Dimensions mm (Inches)	
			E	F
PV2R4A-*-F-RAA-10	M16	M12	29 (1.14)	22 (.87)
PV2R4A-*-F-RAA-1090	5/8-11 UNC	1/2-13 UNC	21 (.83)	21 (.83)

**DIMENSIONS IN MILLIMETRES (INCHES)**

Foot Mtg.: PV2R4A-\*-L-RAA-10/1090

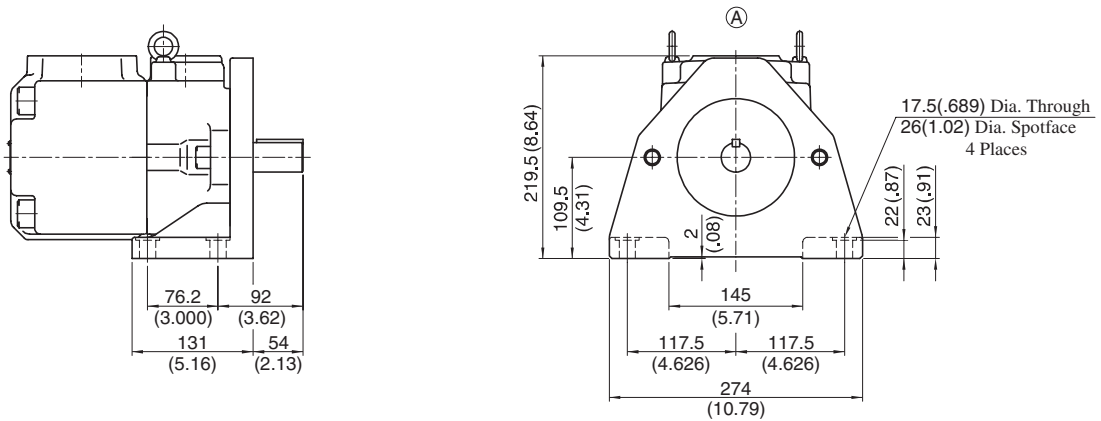

Approx. Mass.....50 kg (110 lbs.)

• For other dimensions, refer to "Flange Mtg.".

■ Noise Level

● Measuring conditions

Fluid viscosity : 20 mm<sup>2</sup>/s (100 SSU)

Measurement point : One metre (3.3 ft.) horizontally away from pump head cover

Back ground noise : 40 dB (A)

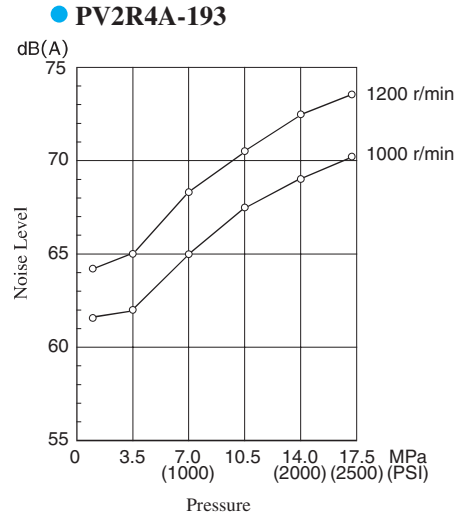
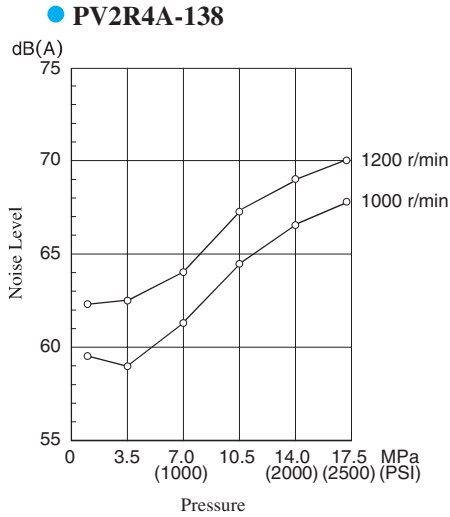

B  
 "PV2R4A" Series  
 Single Vane Pumps

Typical Pump Characteristics at Viscosity 20 mm<sup>2</sup>/s (100 SSU) [ISO VG32 Oils, 50°C (122°F)]

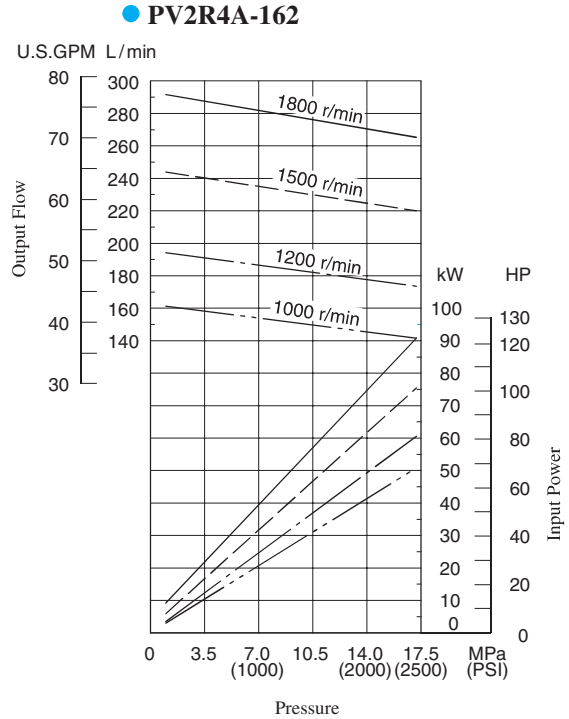
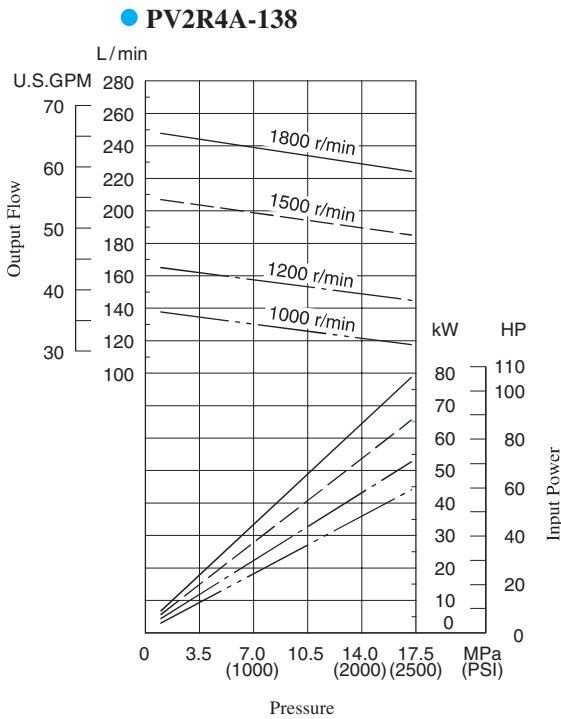

Typical Pump Characteristics at Viscosity 20 mm<sup>2</sup>/s (100 SSU) [ISO VG32 Oils, 50°C (122°F)]

● **PV2R4A-193**

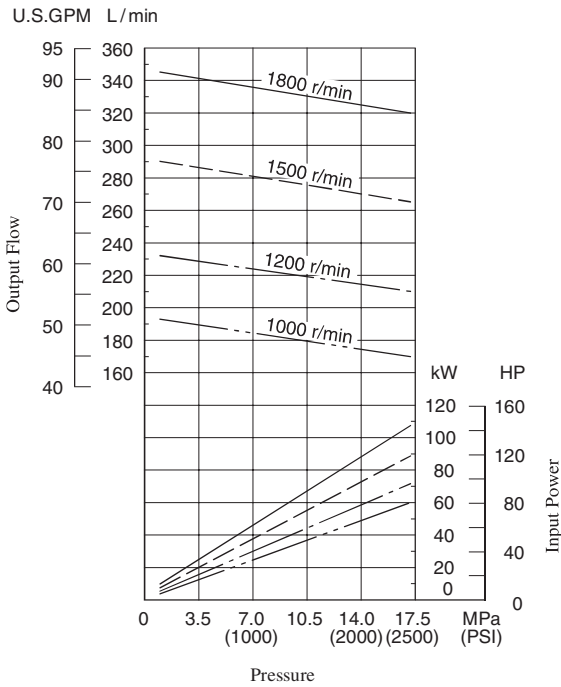

■ Spare Parts List

PV2R4A-\*-\*-RAA-10/1090

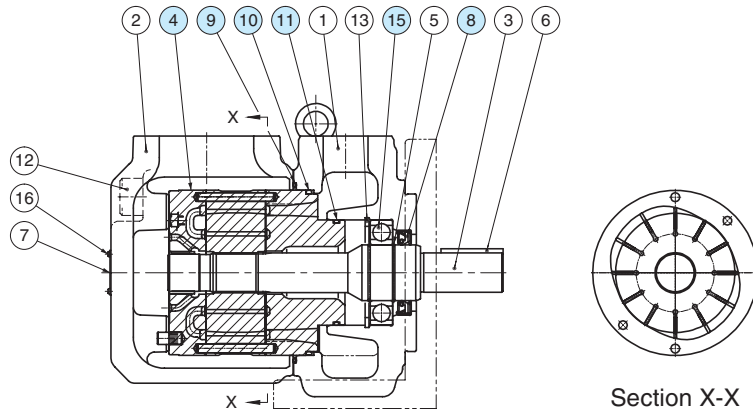

● **Cartridge Kits**

Model Numbers	④ Cartridge Kit Numbers
PV2R4A-138-*-RAA-10*	CPV2R4A-138-R-10
PV2R4A-162-*-RAA-10*	CPV2R4A-162-R-10
PV2R4A-193-*-RAA-10*	CPV2R4A-193-R-10

● **Seals & Bearings**

Item	Name of Parts	Part Numbers	Qty.
8★	Oil Seal	ISD 45 68 12	1
9★	O-Ring	SO-NB-G140	1
10★	O-Ring	SO-NB-A250	1
11★	O-Ring	SO-NB-G80	1
15	Bearing	6209	1

Note: 1) Item Nos. ⑩ and ⑪ (o-rings) are included in cartridge kit.

2) For pumps for phosphate ester type hydraulic fluids different part Nos. are used. Please contact us.

★ When ordering seals, please specify the kit number from the table below.

● **List of Seal Kits**

Pump Model Numbers	Seal Kit Numbers
PV2R4A-*-*-RAA-10/1090	KS-PV2R4A-10