

FILTER - TANK IMMERSED-TIF2

- DIRECT TANK MOUNTING
- PRESSURE - MAX. 10 BAR / TEST 20 BAR / BURST 25 BAR
- ALL ALUMINIUM DIECAST CONSTRUCTION
- 4 - SIZES FLOWS TO 175 LPM
- BY PASS STANDARD 1 BAR
- ELEMENTS REPLACEBLE THROUGH COVER
- SUITABLE FOR MINERAL / PETROLEUM BASED OILS
- MAX TEMP. 80 deg C

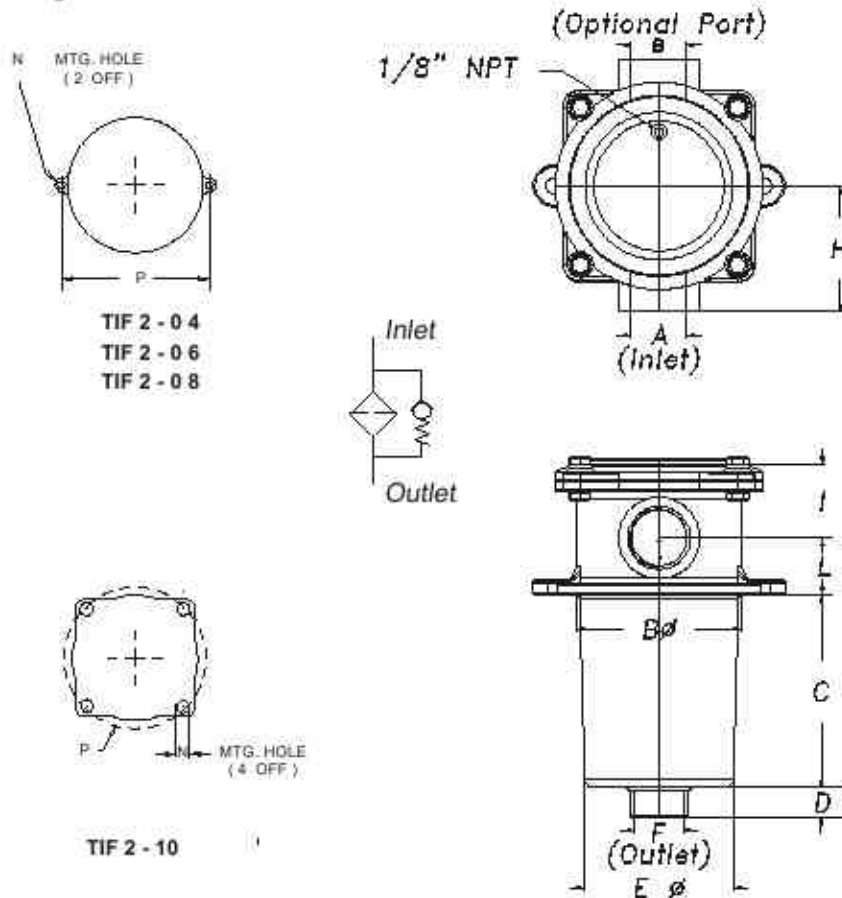

MODEL	PORT 'A' BSPP	PORT 'B' BSPP	TANK CUT OUT B	C	D	E	PORT 'F' BSPP	H	I	L	N	P	WT KGS
TIF2 - 04	1/2"	-	64	60	15	62	1/2"	51	28	24	6.6	90	0.7
TIF2 - 06	3/4"	-	86	75	15	81	3/4"	69	34	26	8.2	114	1.4
TIF2 - 08	1"	-	86	104	15	81	3/4"	68	37	32	8.4	114	1.5
TIF2 - 06 / 08	1"	3/4"	86	104	15	81	3/4"	68	37	32	8.4	114	1.5
TIF2 - 10	1 - 1/4"	1 - 1/4"	129	215	20	122	1 - 1/4"	88	54	44	10.5	175	4.3

FILTER - TANK IMMERSED - TIF

MODEL CODE : ASSEMBLY

TIF 2	- Port A (Std)	- Port B (Optional)	- Element	- Feature
Series	PORT THREAD	PORT THREAD Omit If Not Req'd	- Filtration Micron	- # Omit If Standard
2 - ALL CAST	04 B - 1/2" BSPP		P10 - 10µ NOM	R3 - 15 PSI BYPASS STANDARD
	04 N - 1/2" NPT		P25 - 25µ NOM	
	08 S - 3/4" UNF - 18		A10 - 10µ ABS	
	06 B - 3/4" BSPP		A25 - 25µ ABS	
	06 N - 3/4" NPT		M149 - 149µ MESH	
	12 S - 1-1/16" UNF - 12		M100 - 100µ MESH	
	08 B - 1" BSPP	06 B - 3/4" BSPP	M074 - 074µ MESH	R4 - 25 PSI BYPASS OPTIONAL
	08 N - 1" NPT	06 N - 3/4" NPT	M063 - 063µ MESH	
	16 S - 1-5/16" UNF - 12	12 S - 1-1/16" UNF - 12		
	10 B - 1-1/4" BSPP	10 B - 1-1/4" BSPP		
	10 N - 1-1/4" NPT	10 N - 1-1/4" NPT		
	20 S - 1- 5/8" UNF - 12	20 S - 1- 5/8" UNF - 12		

INDICATOR : OPTIONAL (TO BE ORDERED SEPERATELY)

OPTIONAL / SPECIAL FEATURE - OMIT IF NOT REQUIRED

GR - VISUAL RETURN ER - ELEC. RETURN

Consult Factory For Tapped Holes For Cover Bolts

GS - VISUAL SUCTION ES - ELEC. SUCTION

Element : P10 / P25 Was 010 / 025

MODEL CODE : ELEMENT

TIE	- 08	- 010	- Feature	
SERIES	SIZE	FILTRATION µ MICRON	- # Omit If Standard	
TIE	04	P10 - 10 µ NOM	R3 - 15 PSI BYPASS STANDARD	
		P25 - 25 µ NOM		
	06	A10 - 10 µ ABS		
		A25 - 25 µ ABS		
	08	M149 - 149 µ MESH		R4 - 25 PSI BYPASS OPTIONAL
		M100 - 100 µ MESH		
10	M074 - 074 µ MESH			
	M063 - 063 µ MESH			

WITH BYPASS

MODEL CODE : SEAL KIT

TIF2	- 08	-SK
SERIES	SIZE	SEAL KIT
TIF2	04	SK
	06	SK
	08	SK
	10	SK

OPTIONAL / SPECIAL FEATURE - OMIT IF NOT REQUIRED

Element Details

SIZE	D φ	B φ	H	Area SqCm		
				P-10/25	A-10/25	M - ***
TIE - 04	52	25.5	72	710	500	325
TIE - 06	66	30.5	85	1225	875	425
TIE - 08	66	30.5	130	2450	1750	665
TIE - 10	100	40.5	245	6120	4300	2360

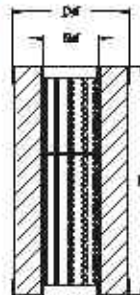

M *** All Mesh Elements

CONSULT FACTORY FOR ANY OTHER REQUIREMENT

