

Vane pumps type PFE-31, PFE-41, PFE-51

fixed displacement

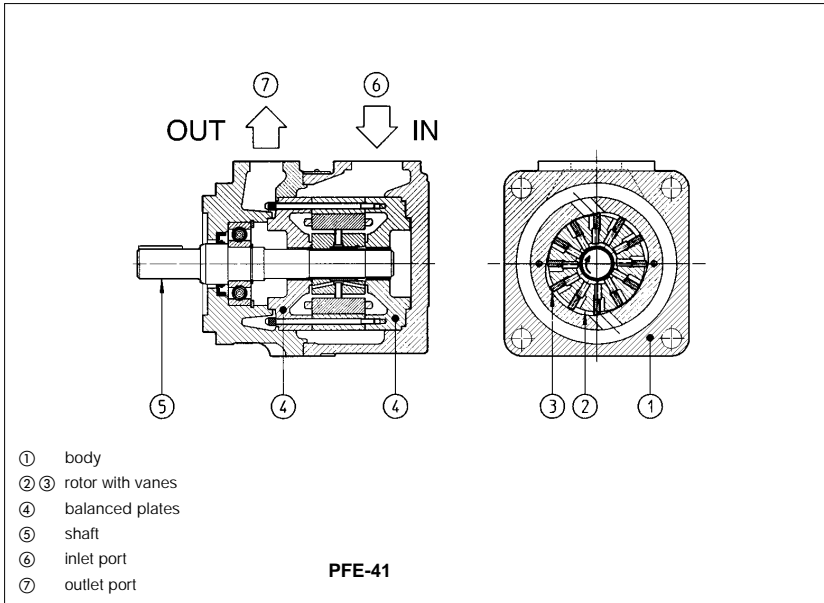

PFE are fixed displacement-twelve-vane pumps, ② ③ cartridge design with integral hydraulic balancing ④ for high pressure operation and long service life with low noise level.

Suitable for hydraulic oils according to DIN 51524... 535 or synthetic fluids having similar lubricating characteristics.

These pumps are available as single, multiple or with through-shaft configuration.

Mounting according to SAE and ISO 3019 standards.

Easy installation as inlet and outlet ports can be assembled in any of four relative positions.

Easy maintenance as the pumping cartridge can be replaced in a few minutes.

Wide variety of displacements up to 150 cm³/rev.

Max pressure 210 bar.

1 MODEL CODE

PFE	X2	- 31	036	/31028	/	1	D	T	**	/*
Fixed displacement vane pump										Synthetic fluids: /PE = phosphate ester for other fluids contact our technical office
Additional suffix for multiple pumps: X2 = double pump composed of single vane pumps X3 = triple pump composed of single vane pumps Eventual suffix for pumps with through shaft: XA = for coupling one PFE-31 XB = for coupling one PFE-41 (only for PFE-41 and PFE-51) XC = for coupling one PFE-51 (only for PFE-51) XO = with through shaft, without rear flange Note: multiple pumps are assembled in decreasing order of size. See also tab. A190.										
Size, see section 2: 31, 41, 51										
Displacement [cm ³ /rev], see section 2: for PFE 31: 016, 022, 028, 036, 044 for PFE 41: 029, 037, 045, 056, 070, 085 for PFE 51: 090, 110, 129, 150										
Only for multiple pumps PFEX*: type of second (and third) pump										
Direction of rotation (as viewed from the shaft end): D = clockwise (supplied standard if not otherwise specified) S = counterclockwise Note: PFE are not reversible										
Drive shaft, see section 6 and 7 : cylindrical, keyed for single and multiple pump (only first position) 1 = standard 2 = according to ISO/DIN 3019 (only for PFE-41 and PFE-51) 3 = for high torque applications splined 5 = for single and multiple pumps (any position) 6 = for single and multiple pumps (only first position) 7 = for second and third position in multiple pumps } only for PFE-31 and PFE-41										
Port orientation, see section 5 : T = standard U, V, W = on request										
Design number										

2 OPERATING CHARACTERISTICS at 1500 rpm with hydraulic oil having a viscosity of 24 mm²/s and 40°C

Model	Displacement cm ³ /rev	Max pressure	Speed range rpm (2)	7 bar (3)		70 bar (3)		140 bar (3)		210 bar (3)	
				l/min	kW	l/min	kW	l/min	kW	l/min	kW
PFE-31016	16,5	210 bar (1)	800-2800	23	0,5	21	3	19	5	16	8,3
PFE-31022	21,6			30	0,6	28	4	26	7	23	10,8
PFE-31028	28,1			40	0,8	38	5,5	36	10	33	14
PFE-31036	35,6			51	1	49	7	46	12,5	43	17,8
PFE-31044	43,7		800-2500	63	1,3	61	8	58	15,5	55	22
PFE-41029	29,3			41	0,8	39	5,5	37	10	34	14,7
PFE-41037	36,6			52	1	50	7	48	12,5	45	18,3
PFE-41045	45,0			64	1,3	62	8,5	60	16	57	22,6
PFE-41056	55,8		800-2000	80	1,6	78	11	75	21	72	28
PFE-41070	69,9			101	2	98	13,5	95	26	91	35
PFE-41085	85,3			124	2,4	121	16	118	32	114	43
PFE-51090	90,0			128	2,7	124	17	119	33	114	45
PFE-51110	109,6		800-2200	157	3,2	152	21	147	40	141	55
PFE-51129	129,2			186	3,7	180	25	174	47	168	65
PFE-51150	150,2			215	4,2	211	29	204	55	197	75

(1) Max pressure is 160 bar for /PE versions
 (2) Max speed is 1800 rpm for /PE versions
 (3) Flow rate and power consumption are proportional to the speed of rotation

3 MAIN CHARACTERISTICS OF VANE PUMPS TYPE PFE-*1

Installation position	Any position.								
Loads on the shaft	Axial and radial loads are not allowed on the shaft. The coupling should be sized to absorb the power peak.								
Ambient temperature	from -20°C to +70°C								
Fluid	Hydraulic oil as per DIN 51524...535; for other fluids see section 11								
Recommended viscosity	<table border="0"> <tr> <td>max at cold start</td> <td>800 mm²/s</td> </tr> <tr> <td>max at full power during operation</td> <td>100 mm²/s</td> </tr> <tr> <td>min at full power</td> <td>24 mm²/s</td> </tr> <tr> <td></td> <td>10 mm²/s</td> </tr> </table>	max at cold start	800 mm ² /s	max at full power during operation	100 mm ² /s	min at full power	24 mm ² /s		10 mm ² /s
max at cold start	800 mm ² /s								
max at full power during operation	100 mm ² /s								
min at full power	24 mm ² /s								
	10 mm ² /s								
Fluid contamination class	ISO 19/16 (filters at 25 μm value with β ₂₅ ≥ 75 recommended)								
Fluid temperature	T < 70°C, if T > 60 select /PE seals								
Recommended pressure on inlet port	from -0,5 to 1,5 bar for speed up to 1800 rpm; from 0 to +1,5 bar for speed over 1800 rpm								

4 DIAGRAMS

1 = Torque versus pressure diagram

2 = **Noise level** measured with ambient conditions according to ISO 4412-1 standards.
 Shaft speed: 1450 rpm.
 Mineral oil having a viscosity of 24 mm²/s and 40°C.

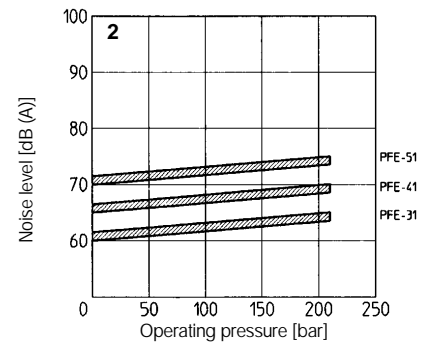
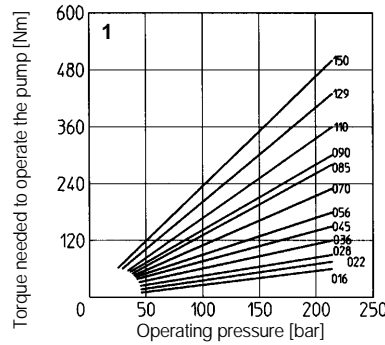

PFE-31:

3 = **Flow versus speed diagram** with pressure variation from 7 bar to 210 bar.

4 = **Power consumption versus speed diagram** at 140 bar. Power consumption is proportional to operating pressure.

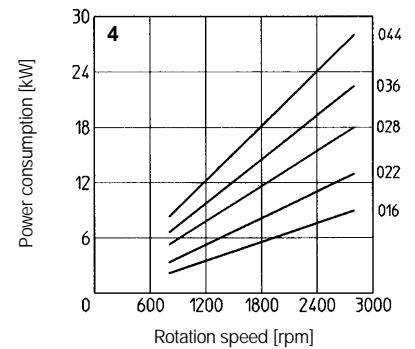
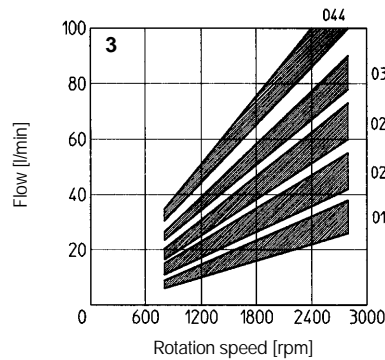

PFE-41:

5 = **Flow versus speed diagram** with pressure variation from 7 bar to 210 bar.

6 = **Power consumption versus speed diagram** at 140 bar. Power consumption is proportional to operating pressure.

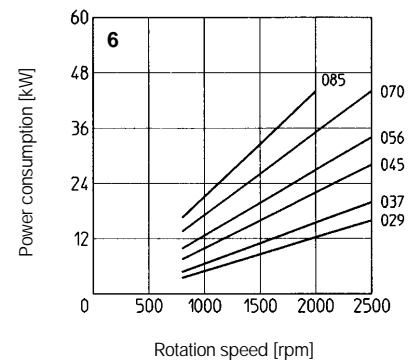
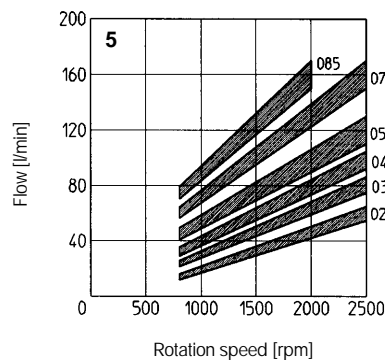

PFE-51:

7 = **Flow versus speed diagram** with pressure variation from 7 bar to 210 bar.

8 = **Power consumption versus speed diagram** at 140 bar. Power consumption is proportional to operating pressure.

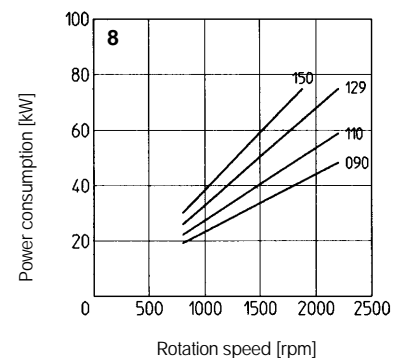
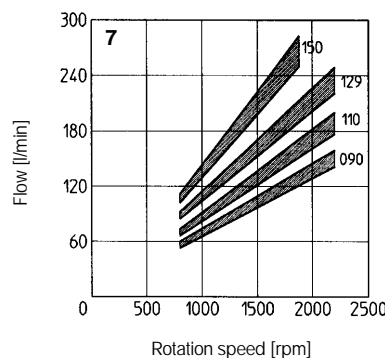

5 PORT ORIENTATION

Single pumps can be supplied with the oil ports oriented in different configuration in relation to the drive shaft, designated as follows (as viewed from the shaft end):

T = inlet and outlet ports on the same axis (standard)

U = outlet orientated 180° with respect to the inlet

V = outlet oriented 90° with respect to the inlet

W = outlet oriented 270° with respect to the inlet

In multiple pumps inlet ports and outlet ports are in line.

Ports orientation can be easily changed by rotating the pump body that carries inlet port.

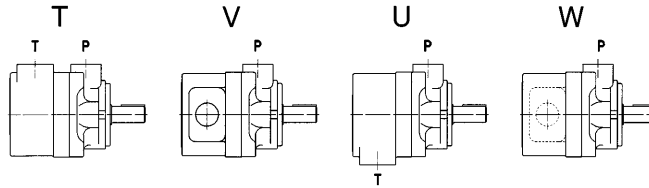

6 DRIVE SHAFT

CYLINDRICAL SHAFT KEYED

- 1 = for single and multiple pumps (only first position) supplied as standard if not specified in the model code
- 2 = for single and multiple pumps (only first position) according to ISO/DIN 3019 standards (only for PFE-41 and PFE-51)
- 3 = for single and multiple pumps (only first position) for high torque applications

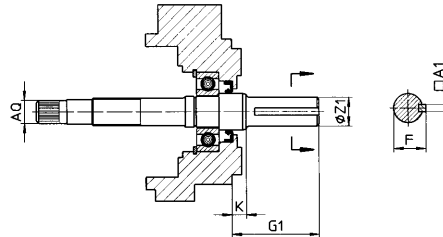

Model	Keyed shaft type 1 (standard)						Keyed shaft type 2						Keyed shaft type 3					
	A1	F	G1	K	ØZ1	Ø AQ	A1	F	G1	K	ØZ1	Ø AQ	A1	F	G1	K	ØZ1	Ø AQ
PFE-31	4,76	21,11	57,50	9,50	19,05	SAE 16/32-9T	-	-	-	-	-	-	4,76	24,54	57,50	9,50	22,22	SAE 16/32-9T
	4,75	20,94			19,00								4,75	24,41			22,20	
PFE-41	4,76	24,54	59,00	11,40	22,22	SAE 32/64-24T	6,36	25,03	71,00	8,00	22,22	SAE 32/64-24T	6,36	28,30	78,00	11,40	25,38	SAE 32/64-24T
	4,75	24,41			22,20		6,35	24,77			22,20		6,35	28,10			25,36	
PFE-51	7,95	35,33	73,00	14	31,75	SAE 16/32-13T	7,95	35,33	84,00	8,10	31,75	SAE 16/32-13T	7,95	38,58	84,00	14	34,90	SAE 16/32-13T
	7,94	35,07			31,70		7,94	35,07			31,70		7,94	38,46			34,88	

SPLINED SHAFT

- 5 = for single and multiple pumps (any position)
 - for PFE-31 according to SAE A 16/32 DP, 9 teeth;
 - for PFE-41 according to SAE B 16/32 DP, 13 teeth;
 - for PFE-51 according to SAE C 12/24 DP, 14 teeth;
- 6 = for single and multiple pumps (only first position)
 - for PFE-31 and PFEX*-31 according to SAE B 16/32 DP, 13 teeth;
 - for PFE-41 and PFEX*-41 according to SAE C 12/24 DP, 14 teeth;
- 7 = for second and third position pump in multiple configuration:
 - for PFEX*-31 according to SAE B 16/32 DP, 13 teeth;
 - for PFEX*-41 according to SAE C 12/24 DP, 14 teeth;

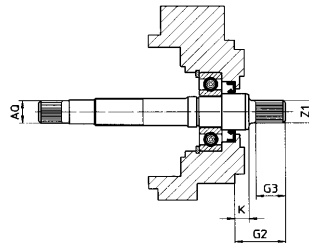

Model	Splined shaft type 5					Splined shaft type 6					Splined shaft type 7				
	G2	G3	K	Z1	Ø AQ	G2	G3	K	Z1	Ø AQ	G2	G3	K	Z1	Ø AQ
PFE-31	33,50	19,50	9,50	SAE 16/32-9T	SAE 16/32-9T	42,50	28	9,50	SAE 16/32-13T	SAE 16/32-9T	33,50	19	9,50	SAE 16/32-13T	SAE 16/32-9T
PFE-41	41,25	28	8,00	SAE 16/32-13T	SAE 32/64-24T	55,60	42	8,00	SAE 12/24-14T	SAE 32/64-24T	41,60	28	8,00	SAE 12/24-14T	SAE 32/64-24T
PFE-51	56,00	42	8,10	SAE 12/24-14T	SAE 16/32-13T	-	-	-	-	-	-	-	-	-	-

7 LIMITS OF SHAFT TORQUE

Pump model	Maximum driving torque [Nm]						Maximum torque available at the end of the through shaft [Nm]
	Shaft type 1	Shaft type 2	Shaft type 3	Shaft type 5	Shaft type 6	Shaft type 7	Any type of shaft
PFE-31	160	-	220	110	220	220	110
PFE-41	250	250	320	200	320	320	200
PFE-51	500	500	700	450	-	-	320

The values of torque needed to operate the pumps are shown for each type on the "torque versus pressure" diagram at section 4.

In multiple pumps the total torque applied to the shaft of the first element (drive shaft) is the sum of the single torque needed for operating each single pump and it is necessary to verify that this total torque applied to the drive shaft is not higher than the values indicated in the table.

8 DIMENSIONS OF SINGLE PUMPS [mm]

T = inlet port
P = outlet port

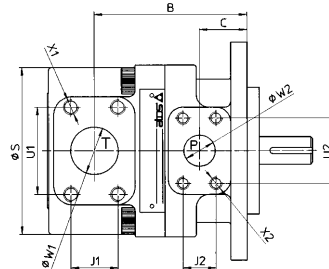
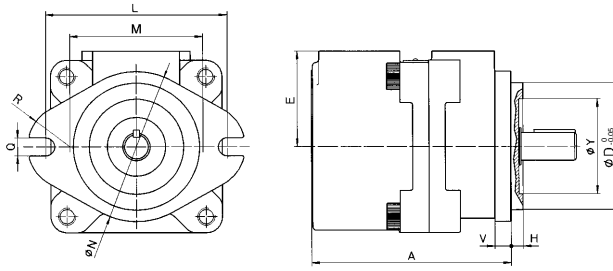

SAE FLANGES

PFE-31: port T = 1 1/4"; port P = 3/4"
PFE-41: port T = 1 1/2"; port P = 1"
PFE-51: port T = 2"; port P = 1 1/4"

Mass:
PFE-31 = 9 kg
PFE-41 = 14 kg
PFE-51 = 25,5 kg

Flanges SAE-3000 can be supplied with the pump, see tab. K120

Model	A	B	C	ØD	E	H	L	M	ØN	Q	R
PFE-31	134,5	98,5	27,5	82,5	70	6,4	106	73	95	11,1	28,5
PFE-41	160	120	38	101,6	76,2	9,7	146	107	120	14,3	34
PFE-51	186,5	125	38	127	82,6	12,7	181	143,5	148	17,5	35
Model	ØS	U1	U2	V	ØW1	ØW2	J1	J2	X1	X2	ØY
PFE-31	114	58,7	47,6	10	32	19	30,2	22,2	M10X20	M10X17	47
PFE-41	134	70	52,4	13	38	25	35,7	26,2	M12X20	M10X17	76
PFE-51	160	77,8	58	15	51	32	42,9	30,2	M12X20	M10X20	76

9 DIMENSIONS OF PUMPS WITH THROUGH-SHAFT (FOR MULTIPLE PUMPS) [mm]

T = inlet port
P = outlet port

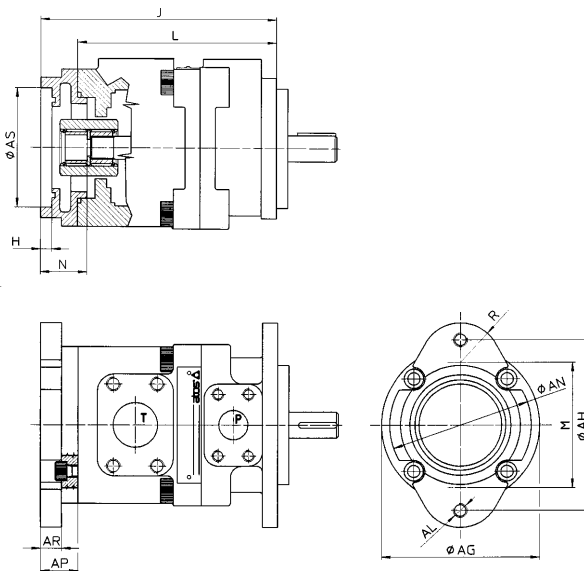

For other dimensions, see section 8

Model	Ø AG	Ø AH	AL	Ø AN	AP	AR	Ø AS	H	J	L	M	N	R
PFEXA-31	114	106	M10X17	95	33	25	82,57 82,63	6,42 6,48	164	131	79	32	28,5
PFEXA-41	134	106	M10X17	95	23	11	82,57 82,63	6,48 6,48	194	171	73	32	28,5
PFEXB-41	134	146	M12	120	32	18	101,62 101,68	9,73 9,78	203	171	107	41	34
PFEXA-51	134	106	M10X17	95	22,7	11	82,57 82,63	6,42 6,43	206,2	183,5	73	32	28,5
PFEXB-51	134	146	M12	120	32	18	101,62 101,68	9,73 9,78	215,5	183,5	107	41	34
PFEXC-51	134	181	M16	148	46,5	30,7	127,02 127,02	12,73 12,78	230	183,5	143,5	56	35