

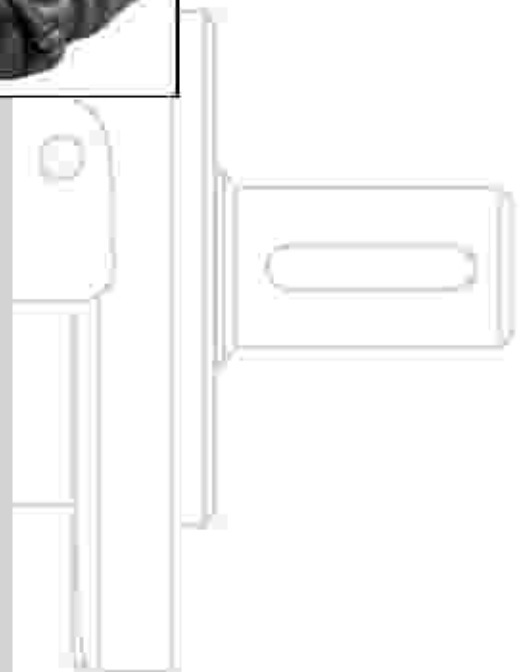

# Orbital Motors Type OMP, OMR and OMH

## Technical Information

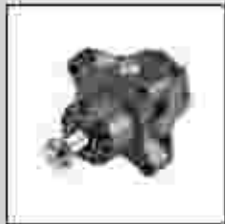

Revision View

Date	Page	Changed	Revision
Mar 2006		Small updates	E
Jun 2007	all	Major revision with new fit-number (minus OMEW, will be prepared separately)	CA
Mar 2010	96	Japan location	CC
Sep 2010	96	New back cover	CD
Sep 2011	48	Types	CE
Nov 2012	3	Planetary Gear deleted	CF

Contents

<b>OMP, OMR and OMH</b> .....	6
Speed, torque and output .....	6
<b>OMP</b> .....	8
Versions .....	8
Code numbers .....	9
Technical data .....	10
Technical data (e.g. speed, torque, pressure etc.) .....	10
Max. permissible shaft seal pressure .....	14
Pressure drop in motor, oil flow in drain line, direction of shaft rotation .....	15
Permissible shaft loads .....	16
Function diagrams .....	20
Shaft version .....	27
Port thread versions .....	29
Dimensions .....	30
<b>OMR</b> .....	40
Versions .....	40
Code Numbers .....	41
Technical data .....	42
Technical data (e.g. speed, torque, pressure etc.) .....	42
Max. permissible shaft seal pressure .....	46
Pressure drop in motor, oil flow in drain line, direction of shaft rotation .....	47
Permissible shaft load .....	48
Function diagrams .....	51
Shaft version .....	56
Port thread versions .....	60
Dimensions .....	61

© 2011 Sauer-Danfoss. All rights reserved.

Sauer-Danfoss accepts no responsibility for possible errors in catalogs, brochures and other printed material. Sauer-Danfoss reserves the right to alter its products without prior notice. This also applies to products already ordered provided that such alterations can be made without affecting agreed specifications. All trademarks in this material are properties of their respective owners: Sauer-Danfoss, the Sauer-Danfoss logotype, the Sauer-Danfoss S-icon, PLUS+1™, What really matters is inside® and Know-How in Motion™ are trademarks of the Sauer-Danfoss Group.

Front cover illustrations: F301 213, F301 214, F301 215, F301 228, F301 229, F301 230. Drawing: 157-1937



# OMP, OMR and OMH Technical Information

## Contents

### Contents

<b>OMH</b> .....	76
Versions.....	76
Code Numbers.....	77
Technical data.....	78
Technical data (e.g. speed, torque, pressure etc.).....	78
Max. permissible shaft seal pressure.....	81
Pressure drop in motor, oil flow in drain line, direction of shaft.....	82
Permissible shaft loads for OMH.....	83
Function diagrams.....	84
Shaft version.....	87
Port thread versions.....	90
Dimensions.....	91
<b>Weight of motors</b> .....	93-95

**A Wide Range of  
Hydraulic Motors**

Sauer-Danfoss is a world leader within production of low speed hydraulic motors with high torque. We can offer more than 3000 different hydraulic motors, categorised in types, variants and sizes (incl. different shaft versions).

The motors vary in size (rated displacement) from 8 cm<sup>3</sup> [0.50 in<sup>3</sup>] to 800 cm<sup>3</sup> [48.9 in<sup>3</sup>] per revolution.

Speeds range up to approx. 2500 min<sup>-1</sup> (rpm) for the smallest type and up to approx 600 min<sup>-1</sup> (rpm) for the largest type.

Maximum operating torques vary from 13 Nm [115 lbf·in] to 2700 Nm [24,000 lbf·in] (peak) and maximum outputs are from 2.0 kW [2.7 hp] to 70 kW [95 hp].

**Characteristic features:**

- Smooth running over the entire speed range
- Constant operating torque over a wide speed range
- High starting torque
- High return pressure without the use of drain line (High pressure shaft seal)
- High efficiency
- Long life under extreme operating conditions
- Robust and compact design
- High radial and axial bearing capacity
- For applications in both open and closed loop hydraulic systems
- Suitable for a wide variety of hydraulics fluids

## OMP, OMR and OMH Technical Information A Wide Range of Hydraulics Motors

The programme is characterised by technical features appealing to a large number of applications and a part of the programme is characterised by motors that can be adapted to a given application. Adaptions comprise the following variants among others:

- Motors with corrosion resistant parts
- Wheel motors with recessed mounting flange
- OMP, OMR- motors with needle bearing
- OMR motor in low leakage version
- OMR motors in a super low leakage version
- Short motors without bearings
- Ultra short motors
- Motors with integrated positive holding brake
- Motors with integrated negative holding brake
- Motors with integrated flushing valve
- Motors with speed sensor
- Motors with tachometer connection
- All motors are available with black finish paint

The Sauer-Danfoss LSHT motors are used in the following application areas:

- Construction equipment
- Agricultural equipment
- Material handling & Lifting equipment
- Forestry equipment
- Lawn and turf equipment
- Special purpose
- Machine tools and stationary equipment
- Marine equipment

### Survey of Literature with Technical Data on Sauer-Danfoss Hydraulic Motors

Detailed data on all Sauer-Danfoss motors can be found in our motor catalogue, which is divided into 8 individual subcatalogues:

- General information on Sauer-Danfoss hydraulic motors: function, use, selection of hydraulic motor, hydraulic systems, etc.
- Technical data on small motors: OML and OMM
- Technical data on medium sized motors: OMP, OMR and OMH
- Technical data on medium sized motors: DH and DS
- Technical data on medium sized motors: OMEW
- Technical data on large motors: OMS, OMT and OMV
- Technical data on large motors: TMK
- Technical data on large motors: TMT
- Technical data on large motors: TMVW

A general survey brochure on Sauer-Danfoss hydraulic motors gives a quick motor reference based on power, torque, speed and capabilities.

Speed, Torque and Output

Max. speed

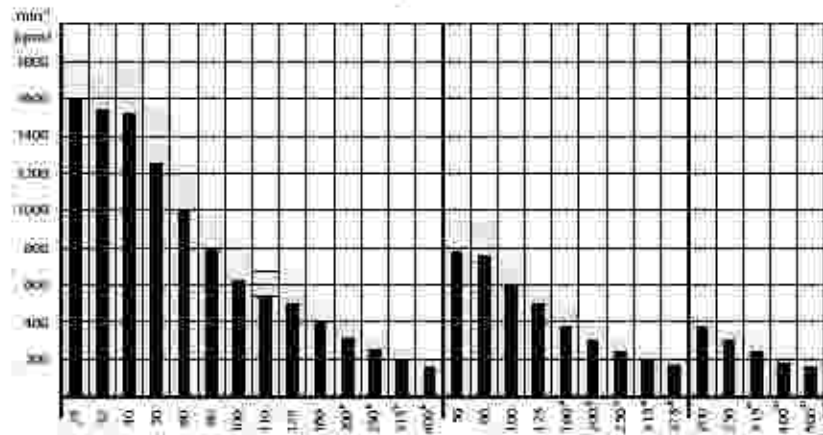

Max. Torque

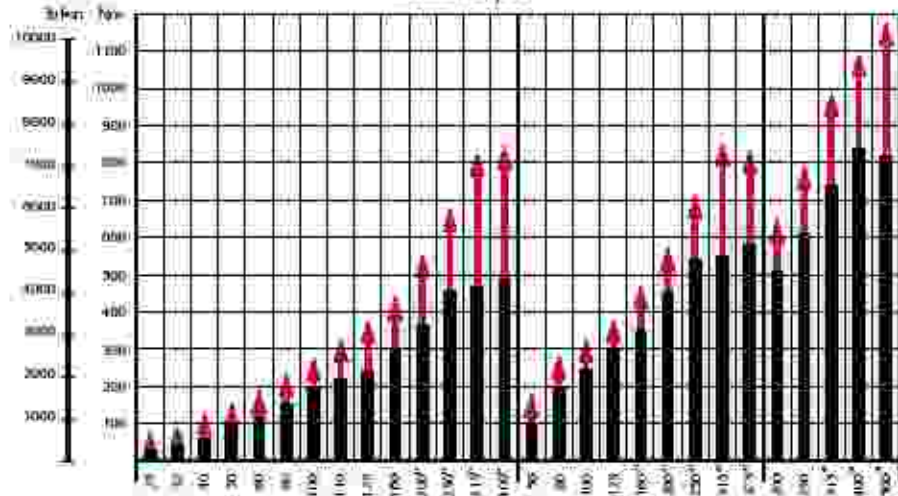

Max. output

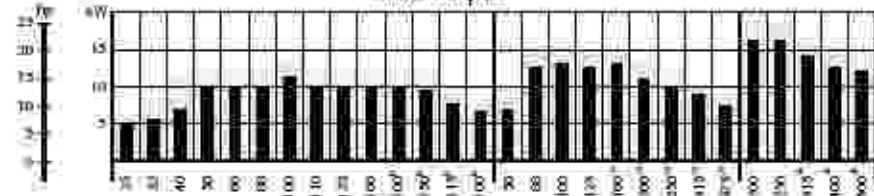

OMP OMR OMH

Peak value Intermittent Values Continuous Values

MF-14/8/11

- 1) 1 1/4 in shaft
- 2) 1 1/4 in or 1 1/4 in tapered shaft
- 3) 1 1/4 in splined shaft

## OMP, OMR and OMH Technical Information A Wide Range of Hydraulics Motors

### Speed, Torque and Output

The bar diagrams above are useful for a quick selection of relevant motor size for the application. The final motor size can be determined by using the function diagram for each motor size.

- OMP and OMPW can be found on pages 20 - 26
- OMR and OMRW can be found on pages 51 - 55
- OMH can be found on pages 84 - 86

The function diagrams are based on actual tests on a representative number of motors from our production. The diagrams apply to a return pressure between 5 and 10 bar [75 and 150 psi] when using mineral based hydraulic oil with a viscosity of 35 mm<sup>2</sup>/s [165 SUS] and a temperature of 50°C [120°F]. For further explanation concerning how to read and use the function diagrams, please consult the paragraph "Selection of motor size" in the technical information "General Orbital Motors" 520L0232 Rev. B.

Versions

Mounting flange	Spigot diameter (front / rear end)	Bolt circle diameter (BC)	Shaft	Port size	European version	US version	Side port version	End port version	Flange port version	Standard shaft seal	High pressure shaft seal	Drain connection	Check valve	Main type designation	
1 hole oval flange (A2-flange)	Ø 82.5 mm (3.25 in)	Ø 106.4 mm (4.20 in)	Cyl. 25 mm	G 1/2	•		•				•	No	No	OMP	
				G 3/4	•		•				•	Yes	No	OMP	
				G 1	•			•			•	Yes	Yes	OMP	
			Cyl. 1 inch	G 1/2	•		•					•	No	No	OMP
				G 3/4	•		•					•	Yes	No	OMP
				1/2-14 UNF		•	•					•	Yes	Yes	OMP
			Splined 1 inch	G 1/2	•		•					•	No	No	OMP
				G 3/4	•		•					•	Yes	No	OMP
4 hole oval flange (A4-flange)	Ø 82.5 mm (3.25 in)	Ø 106.4 mm (4.20 in)	Cyl. 32 mm	G 1/2	•		•		•		Yes	Yes	OMP		
Square flange (K-flange)	Ø 44.4 mm (1.75 in)	Ø 82.5 mm (3.25 in)	Cyl. 25 mm	G 1/2	•			•		•		Yes	Yes	OMP	
			Cyl. 1 inch	1/2-14 UNF		•	•			•		Yes	Yes	OMP	
				1/2-14 NPT		•	•			•		Yes	Yes	OMP	
Wheel	Ø 80 mm (3.15 in)	Ø 103 mm (4.06 in)	Cyl. 25 mm	G 1/2	•				•	•	Yes	Yes	OMPW		
<b>OMP motors with corrosion resistant parts</b>															
1 hole oval flange (A2-flange)	Ø 82.5 mm (3.25 in)	Ø 106.4 mm (4.20 in)	Cyl. 25 mm	G 1/2	•		•			•		Yes	Yes	OMP C	
<b>OMP motors with needle bearings</b>															
1 hole oval flange (A2-flange)	Ø 82.5 mm (3.25 in)	Ø 106.4 mm (4.20 in)	Cyl. 25 mm	G 1/2	•		•			•		Yes	Yes	OMP N	
Wheel	Ø 80 mm (3.15 in)	Ø 103 mm (4.06 in)	Tap 28.5 mm	G 1/2	•				•	•		Yes	Yes	OMPW N	
<b>OMP motors with free running gerotor</b>															
1 hole oval flange (A2-flange)	Ø 82.5 mm (3.25 in)	Ø 106.4 mm (4.20 in)	Cyl. 25 mm	G 1/2	•		•				•	Yes	No	OMP	
														Functions diagram - see page →	

Features available (options):  
 Low leakage (low speed valve)  
 Speed sensor  
 Viton shaft seal  
 Reverse rotation  
 Painted



Code Numbers

Code numbers	Displacement [cm <sup>3</sup> ]														Technical data - Page	Dimensions - Page
	25	32	40	50	60	80	100	110	125	160	200	250	315	400		
151-	0340	0341	0342	0310	0319	0311	0312	-	0313	0314	0315	0316	0317	0318	10	30
151-	0640	0641	0642	0610	-	0611	0612	0646	0613	0614	0615	0616	0617	0618	10	31
151-	-	-	-	5191	-	5192	5193	-	5194	5195	5196	5197	5198	5199	10	33
151-	-	-	-	0300	-	0301	0302	-	0303	0304	0305	0306	0307	0308	10	30
151-	-	-	-	0600	-	0601	0602	-	0603	0604	0605	0606	0607	0608	10	31
151-	7090	7091	7092	7041	-	7042	7043	-	7044*	7045	7046	7047	7048	7049	10	34
151-	-	-	-	0330	-	0331	0332	-	0333	0334	0335	0336	0337	0338	12	30
151-	-	-	-	0630	-	0631	0632	-	0633	0634	0635	0636	0637	0638	12	31
151-	-	5010	-	5001	-	5002	5003	-	5004	5005	5006	5007	5008	5009	13	35
151-	-	-	-	5211	-	5212	5213	-	5214	5215	5216	5217	5218	5219	10	36
151-	-	-	-	7061	-	7062	7063	-	7074	7065	7066	7067	7068	7069	10	37
151-	-	-	-	7021	-	7022	7023	-	7024	7025	7026	7027	7028	7029	10	37
151-	-	-	-	7101	-	7102	7103	-	7104	7105	7106	7107	7108	7109	10	38
<b>OMP motors with corrosion resistant parts:</b>																
151-	-	-	-	1208	-	1209	1210	-	1217	1211	1212	1213	1214	1215	10	32
<b>OMP motors with needle bearings:</b>																
151-	-	-	-	5311	-	5312	5313	-	-	5315	5316	-	5318	-	10	32
151-	-	-	-	5301	-	5302	5303	-	5304	5305	5306	5307	5308	5309	12	38
<b>OMP motors with free running gerotor</b>																
151-	-	-	-	-	-	-	0622	-	-	0624	0625	-	0627	-	10	31
	20	20	21	21	22	22	23	23	24	24	25	25	26	26		

\* Motor painted black.

Ordering

Add the four digit prefix "151-" to the four digit numbers from the chart for complete code number.

Example:

151-0305 for an OMP 200 with A2 flange; cyl. 1 in shaft; port size G 1/2 and high pressure shaft seal.

Orders will not be accepted without the four digit prefix.

Technical data for OMP with 25 mm and ↑ in cylindrical shaft

Type			OMP	OMP	OMP	OMP	OMP	OMP		
Motor size			25	32	40	50	60	80	100	
Geometrical displacement	cm <sup>3</sup> [inch <sup>3</sup> ]		23.0 [1.33]	32.0 [1.96]	40.0 [2.43]	48.6 [2.97]	59.1 [3.61]	77.8 [4.76]	97.3 [5.93]	
Max. speed	min <sup>-1</sup> [rpm]	cont.	1600	1560	1500	1230	1000	770	615	
		int. <sup>1)</sup>	1800	1720	1750	1340	1250	960	770	
Max. torque	N·m [lbf·ft]	cont.	33 [240]	43 [316]	52 [380]	63 [460]	115 [830]	150 [1100]	190 [1390]	230 [1690]
		int. <sup>1)</sup>	47 [340]	61 [440]	74 [540]	120 [870]	140 [1020]	190 [1390]	230 [1690]	
		peak <sup>2)</sup>	67 [490]	86 [630]	107 [780]	140 [1020]	180 [1320]	220 [1610]	270 [1980]	
Max. output	kW [hp]	cont.	4.5 [6.0]	5.8 [7.8]	7.0 [9.4]	10.0 [13.4]	10.0 [13.4]	10.0 [13.4]	13.0 [17.8]	
		int. <sup>1)</sup>	6.1 [8.2]	7.8 [10.5]	10.6 [14.2]	12.0 [16.1]	12.0 [16.1]	12.0 [16.1]	13.0 [17.4]	
Max. pressure drop	bar [psi]	cont.	100 [1450]	100 [1450]	100 [1450]	140 [2030]	140 [2030]	140 [2030]	140 [2030]	
		int. <sup>1)</sup>	140 [2030]	140 [2030]	140 [2030]	175 [2540]	175 [2540]	175 [2540]	175 [2540]	
		peak <sup>2)</sup>	225 [3260]	225 [3260]	225 [3260]	225 [3260]	225 [3260]	225 [3260]	225 [3260]	
Max. oil flow	l/min [US gal/min]	cont.	40 [10.6]	50 [13.2]	60 [15.9]	60 [15.9]	60 [15.9]	60 [15.9]	60 [15.9]	
		int. <sup>1)</sup>	45 [11.9]	55 [14.5]	70 [18.5]	75 [19.8]	75 [19.8]	75 [19.8]	75 [19.8]	
Max. starting pressure with unloaded shaft	bar [psi]	standard	10 [14.5]	10 [14.5]	10 [14.5]	10 [14.5]	10 [14.5]	10 [14.5]	10 [14.5]	
		free running generator	-	-	-	-	-	-	-	2 [29]
Min. starting torque	N·m [lbf·ft]	at max. press. drop, cont.	30 [220]	40 [295]	45 [330]	60 [440]	100 [735]	135 [1000]	170 [1250]	
		at max. press. drop, int. <sup>1)</sup>	40 [295]	55 [400]	63 [460]	100 [735]	120 [880]	170 [1250]	210 [1540]	

<sup>1)</sup>Intermittent operation; the permissible values may occur for max. 10% of every minute.

<sup>2)</sup>Peak load; the permissible values may occur for max. 1% of every minute.

Technical data for OMP with 25 mm and 1 in cylindrical shaft (continued)

Type			OMP 110	OMP 125	OMP 160	OMP 200	OMP 250	OMP 315	OMP 400
Motor size			110	125	160	200	250	315	400
Geometric displacement	cm <sup>3</sup> [Inch <sup>3</sup> ]		112.9 [6.97]	125.0 [7.63]	155.7 [9.53]	194.6 [11.91]	242.3 [14.93]	306.1 [18.73]	389.2 [23.83]
Max. speed	min <sup>-1</sup> [rpm]	cont.	535	480	385	310	250	195	155
		int. <sup>1)</sup>	670	600	480	385	310	245	190
Max. torque	N·m [lbf·in]	cont.	215 [1900]	240 [2120]	300 [2660]	300 [2660]	300 [2660]	300 [2660]	300 [2660]
		int. <sup>2)</sup>	260 [2300]	290 [2570]	370 [3280]	380 [3360]	410 [3630]	390 [3450]	420 [3720]
		peak <sup>2)</sup>	320 [2830]	370 [3280]	430 [3810]	540 [4780]	550 [4870]	600 [5310]	600 [5310]
Max. output	kW [hp]	cont.	10 [13.4]	10 [13.4]	10 [13.4]	9.0 [12.2]	8.0 [10.7]	7.0 [9.5]	6.0 [8.1]
		int. <sup>2)</sup>	12.0 [16.1]	12.0 [16.1]	12.0 [16.1]	11.0 [14.8]	9.0 [12.1]	7.0 [9.4]	6.0 [8.1]
Max. pressure drop	bar [psf]	cont.	140 [2030]	140 [2030]	140 [2030]	133 [1870]	90 [1270]	75 [1060]	60 [840]
		int. <sup>2)</sup>	175 [2540]	175 [2540]	175 [2540]	150 [2100]	125 [1750]	100 [1400]	80 [1120]
		peak <sup>2)</sup>	225 [3200]	225 [3200]	225 [3200]	225 [3200]	180 [2610]	160 [2220]	130 [1890]
Max. oil flow	l/min [US gal/min]	cont.	60 [15.9]	60 [15.9]	60 [15.9]	60 [15.9]	60 [15.9]	60 [15.9]	60 [15.9]
		int. <sup>2)</sup>	75 [19.8]	75 [19.8]	75 [19.8]	75 [19.8]	75 [19.8]	75 [19.8]	75 [19.8]
Max. starting pressure with unloaded shaft	bar [psi]	standart	10 [143]	8 [113]	7 [100]	5 [73]	5 [73]	5 [73]	5 [73]
		free running period	-	2 [29]	2 [29]	2 [29]	-	-	-
Min starting torque	N·m [lbf·in]	at max. press.dropt cont.	180 [1600]	210 [1860]	280 [2480]	270 [2390]	280 [2480]	280 [2480]	280 [2480]
		at max. press.dropt int. <sup>2)</sup>	240 [2120]	270 [2390]	350 [3100]	360 [3190]	390 [3450]	370 [3280]	400 [3540]

<sup>1)</sup> Intermittent operation; the permissible values may occur for max. 10% of every minute.

<sup>2)</sup> Peak load; the permissible values may occur for max. 1% of every minute.

Technical data for OMP with 1 in. splined and 28.5 mm tapered shaft

Type		OMP 50	OMP 80	OMP 100	OMP 125	OMP 160	OMP 200	OMP 250	OMP 315	OMP 400	
Motor size		50	80	100	125	160	200	250	315	400	
Geometric displacement	cm <sup>3</sup> [inch <sup>3</sup> ]	48.6 [2.97]	77.8 [4.76]	97.3 [5.95]	125.0 [7.65]	155.7 [9.53]	194.6 [11.91]	242.3 [14.83]	306.1 [18.73]	389.2 [23.82]	
Max. speed	min. <sup>-1</sup> [rpm]	cont.	1230	770	615	480	385	310	250	195	155
		int. <sup>1)</sup>	1540	960	770	600	480	385	310	245	190
Max. torque	N·m [lbf·in]	cont.	93 [820]	150 [1330]	199 [1880]	240 [2120]	300 [2680]	380 [3190]	360 [3190]	360 [3190]	360 [3190]
		int. <sup>1)</sup>	120 [1060]	190 [1680]	230 [2040]	290 [2570]	370 [3280]	450 [3980]	460 [4070]	470 [4160]	460 [4070]
		peak <sup>2)</sup>	140 [1240]	220 [1950]	270 [2390]	370 [3280]	430 [3810]	540 [4780]	550 [4870]	540 [4760]	560 [4960]
Max. output	kW [hp]	cont.	10.0 [13.4]	10.0 [13.4]	11.0 [14.8]	10.0 [13.4]	10.0 [13.4]	10.0 [13.4]	8.0 [10.7]	6.0 [8.0]	3.0 [6.7]
		int. <sup>1)</sup>	12.0 [16.1]	12.0 [16.1]	13 [17.4]	12.0 [16.1]	12.0 [16.1]	12.0 [16.1]	10.5 [14.1]	7.5 [10.1]	6.0 [8.0]
Max. pressure drop	bar [psi]	cont.	140 [2030]	140 [2030]	140 [2030]	140 [2030]	140 [2030]	140 [2030]	165 [2370]	90 [1290]	70 [1020]
		int. <sup>1)</sup>	175 [2540]	175 [2540]	175 [2540]	175 [2540]	175 [2540]	175 [2540]	140 [2030]	120 [1740]	90 [1310]
		peak <sup>2)</sup>	225 [3260]	225 [3260]	225 [3260]	225 [3260]	225 [3260]	225 [3260]	190 [2610]	160 [2220]	130 [1880]
Max. oil flow	l/min [US gal/min]	cont.	60 [15.9]	60 [15.9]	60 [15.9]	60 [15.9]	60 [15.9]	60 [15.9]	60 [15.9]	60 [15.9]	60 [15.9]
		int. <sup>1)</sup>	75 [19.8]	75 [19.8]	75 [19.8]	75 [19.8]	75 [19.8]	75 [19.8]	75 [19.8]	75 [19.8]	75 [19.8]
Max. starting pressure with unloaded shaft	bar [psi]	10 [145]	10 [145]	10 [145]	9 [130]	7 [100]	5 [75]	5 [75]	5 [75]	5 [75]	
Min. starting torque	at max. press. drop cont.	80 [710]	135 [1200]	170 [1510]	210 [1860]	290 [2480]	340 [3010]	330 [2920]	340 [3010]	345 [3050]	
	at max. press. drop int. <sup>1)</sup>	100 [890]	170 [1510]	210 [1880]	270 [2390]	350 [3100]	420 [3720]	440 [3890]	450 [3980]	425 [3760]	

<sup>1)</sup> Intermittent operation, the permissible values may occur for max. 10% of every minute.

<sup>2)</sup> Peak load, the permissible values may occur for max. 1% of every minute.

Technical data for OMP with 32 mm cylindrical shaft

Type		OMP 50	OMP 80	OMP 100	OMP 125	OMP 160	OMP 200	OMP 250	OMP 315	OMP 400	
Motor size		50	80	100	125	160	200	250	315	400	
Geometric displacement	cm <sup>3</sup> [in <sup>3</sup> ]	48.6 [2.97]	77.8 [4.76]	97.3 [5.95]	125.0 [7.65]	155.7 [9.53]	194.6 [11.91]	242.3 [14.83]	306.1 [18.73]	389.2 [23.82]	
Max. speed	min <sup>-1</sup> [rpm]	cont <sup>1)</sup>	1230	770	615	480	385	310	250	195	
		int <sup>2)</sup>	1540	960	770	600	480	385	310	245	190
Max. torque	N·m [lbf·ft]	cont <sup>1)</sup>	93 [6.80]	150 [11.30]	190 [14.00]	240 [17.80]	300 [22.00]	360 [26.60]	460 [34.00]	470 [34.80]	490 [36.00]
		int <sup>2)</sup>	120 [8.80]	199 [14.60]	230 [17.00]	290 [21.50]	370 [27.30]	450 [33.00]	570 [42.00]	620 [45.60]	630 [46.20]
		peak <sup>3)</sup>	140 [10.30]	220 [16.30]	270 [19.90]	370 [27.30]	430 [31.70]	540 [39.70]	670 [49.50]	820 [60.50]	840 [61.70]
Max. output	kW [hp]	cont <sup>1)</sup>	10.0 [13.4]	10.0 [13.4]	11.0 [14.8]	10.0 [13.4]	10.0 [13.4]	10.0 [13.4]	9.5 [12.7]	7.3 [10.1]	6.5 [8.7]
		int <sup>2)</sup>	12.0 [16.1]	12.0 [16.1]	13.0 [17.4]	12.0 [16.1]	12.0 [16.1]	12.0 [16.1]	12.0 [16.1]	9.0 [12.1]	7.3 [10.1]
Max. pressure drop	bar [psi]	cont <sup>1)</sup>	140 [2030]	140 [2030]	140 [2030]	140 [2030]	140 [2030]	140 [2030]	140 [2030]	120 [1740]	65 [930]
		int <sup>2)</sup>	175 [2540]	175 [2540]	175 [2540]	175 [2540]	175 [2540]	175 [2540]	175 [2540]	180 [2610]	125 [1810]
		peak <sup>3)</sup>	225 [3260]	225 [3260]	225 [3260]	225 [3260]	225 [3260]	225 [3260]	225 [3260]	225 [3260]	190 [2750]
Max. oil flow	l/min [US gal/min]	cont <sup>1)</sup>	60 [15.9]	60 [15.9]	60 [15.9]	60 [15.9]	60 [15.9]	60 [15.9]	60 [15.9]	60 [15.9]	
		int <sup>2)</sup>	75 [19.8]	75 [19.8]	75 [19.8]	75 [19.8]	75 [19.8]	75 [19.8]	75 [19.8]	75 [19.8]	75 [19.8]
Max. starting pressure with unloaded shaft	bar [psi]	10 [145]	10 [145]	10 [145]	9 [130]	7 [100]	5 [75]	5 [75]	5 [75]	5 [75]	
Min. starting torque	at max. press. drop cont <sup>1)</sup>	30 [210]	133 [1200]	170 [1510]	210 [1860]	280 [2480]	240 [2010]	420 [3720]	460 [4070]	460 [4070]	
	at max. press. drop int <sup>2)</sup>	100 [900]	170 [1510]	210 [1860]	270 [2390]	350 [3100]	420 [3720]	330 [2970]	600 [5310]	600 [5310]	

Type			Max. inlet pressure	Max. return pressure with drain line
OMP 25 - 400	bar [psi]	cont <sup>1)</sup>	175 [2540]	175 [2540]
	bar [psi]	int <sup>2)</sup>	200 [2900]	200 [2900]
	bar [psi]	peak <sup>3)</sup>	225 [3260]	225 [3260]

<sup>1)</sup> Intermittent operation; the permissible values may occur for max. 10% of every minute.

<sup>2)</sup> Peak load; the permissible values may occur for max. 1% of every minute.

# OMP

## Technical Information

### Technical Data - Max. Permissible Shaft Seal Pressure

#### OMP with HIGH Pressure Shaft Seal (HPS)

OMP with HPS and without drain connection:  
The shaft seal pressure equals the average of input pressure and return pressure.

$$P_{\text{seal}} = \frac{P_{\text{in}} + P_{\text{return}}}{2}$$

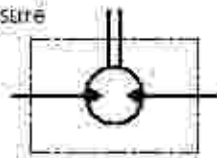

151-109310

OMP with HPS and drain connection:  
The shaft seal pressure equals the pressure in the drain line.

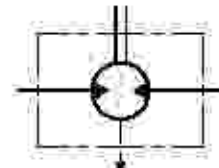

151-185810

#### Max. permissible shaft seal pressure

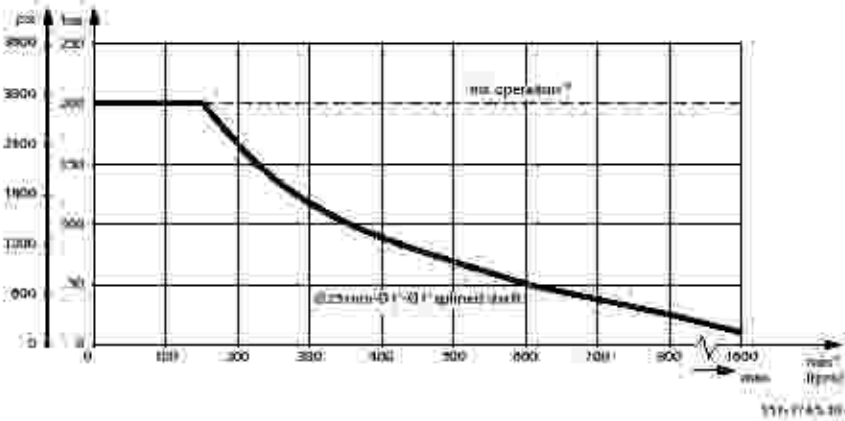

#### OMP with Standard Shaft Seal

OMP with standard shaft seal, check valves and without use of drain connection:  
The pressure on the shaft seal never exceeds the pressure in the return line.

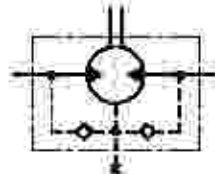

151-88810

OMP with standard shaft seal, check valves and with drain connection:  
The shaft seal pressure equals the pressure on the drain line.

#### Max. return pressure without drain line or max. pressure in the drain line

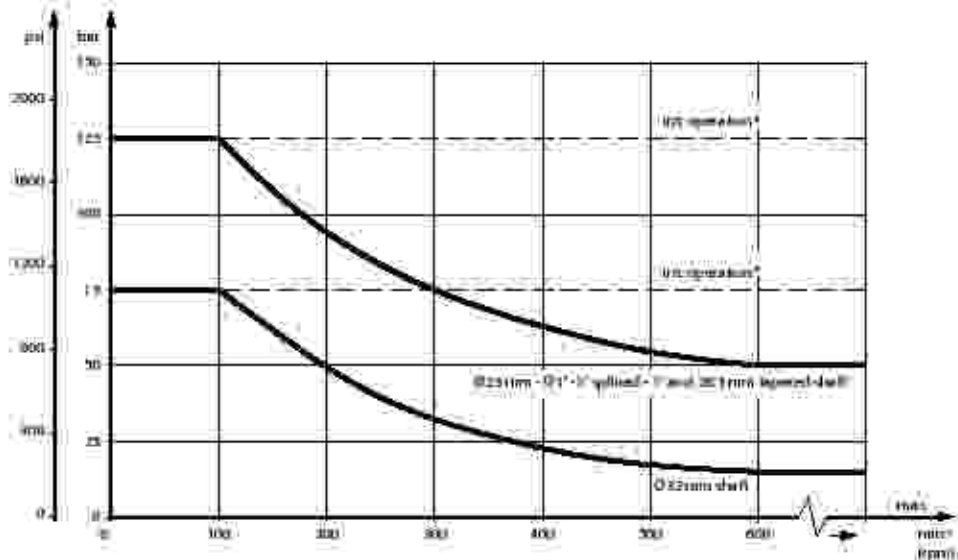

1) Intermittent operation: the permissible values may occur for max. 10% of every minute.

151-156310

**Pressure Drop in Motor**

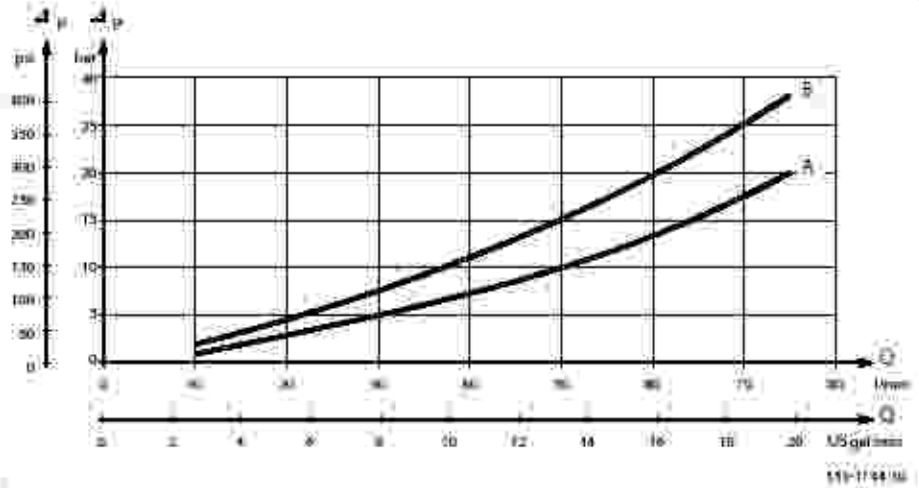

The curve applies to an unloaded motor shaft and an oil viscosity of 35 mm<sup>2</sup>/s [1.65 SUS]

- A: OMP 50-400
- B: OMP 25-40 / OMPW

**Oil Flow in Drain Line**

The table shows the max. oil flow in the drain line at a return pressure less than 5-10 bar [75-150 psi]

Pressure drop bar (psi)	Viscosity mm <sup>2</sup> /s (SUS)	Oil flow in drain line l/min. (US gal/min)
100 [1450]	20 [100]	2.5 [0.66]
	35 [165]	1.8 [0.48]
140 [2030]	20 [100]	3.5 [0.93]
	35 [165]	2.8 [0.74]

**Direction of Shaft Rotation**

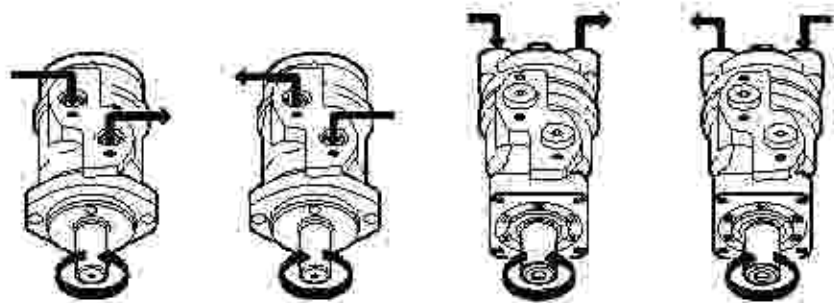

T11-185011

The permissible radial shaft load ( $P_R$ ) depends on

- Speed ( $n$ )
- Distance ( $l$ ) from the point of load to the mounting flange
- Mounting flange version
- Shaft version

Mounting flange	4-oval flange** 2-hole oval flange (European version)	4-hole oval flange	Square flange** 2-hole oval flange (US-version)
Shaft version	25 mm cylindrical shaft 1 in cylindrical shaft 1 in splined shaft	32 mm cylindrical shaft	25 mm cylindrical shaft
Permissible shaft load ( $P_R$ ) - l in mm	$\frac{800}{n} \cdot \frac{250000}{95 + l}$ N*	$\frac{800}{n} \cdot \frac{187500}{95 + l}$ N*	$\frac{800}{n} \cdot \frac{250000}{101 + l}$ N*
Permissible shaft load ( $P_R$ ) - l in inch	$\frac{800}{n} \cdot \frac{2215}{3.74 + l}$ lbf*	$\frac{800}{n} \cdot \frac{1660}{3.74 + l}$ lbf*	$\frac{800}{n} \cdot \frac{2215}{3.98 + l}$ lbf*

- \*  $n \geq 200 \text{ min}^{-1}$  (rpm):  $l \leq 55 \text{ mm}$  (2.2 in)
- $n < 200 \text{ min}^{-1}$  (rpm):  $l = > P_{Rmax} = 8000 \text{ N}$  (1800 lbf)
- \*\* For both European and US-version

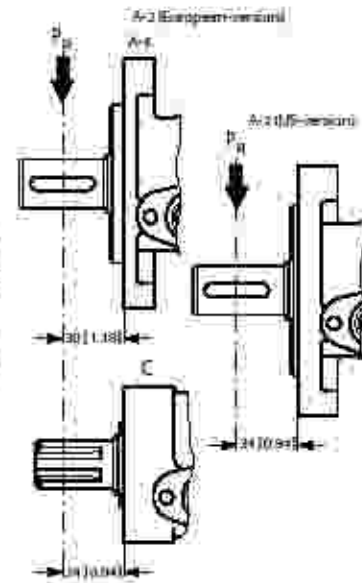
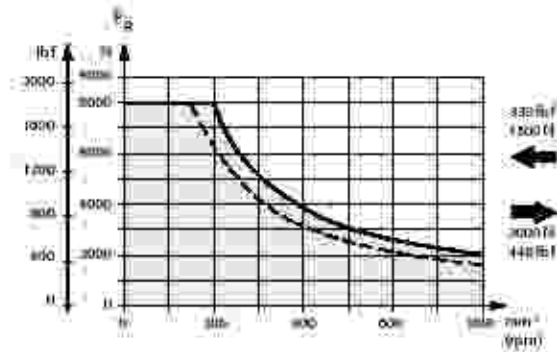

159-1-003-00

- cylindrical shaft 32 mm (1.26 in)
- - - other shaft versions

The curve shows the relation between  $P_R$  and  $n$

- when  $l = 30 \text{ mm}$  (1.18 in) for motors with A2 (European version) and A4 oval mounting flange
- when  $l = 24 \text{ mm}$  (0.94 in) for motors with square mounting flange and A2 (US version)

For applications with special performance requirements we recommend OMP with the output shaft running in needle bearings.



Permissible Shaft Load  
 for OMP N

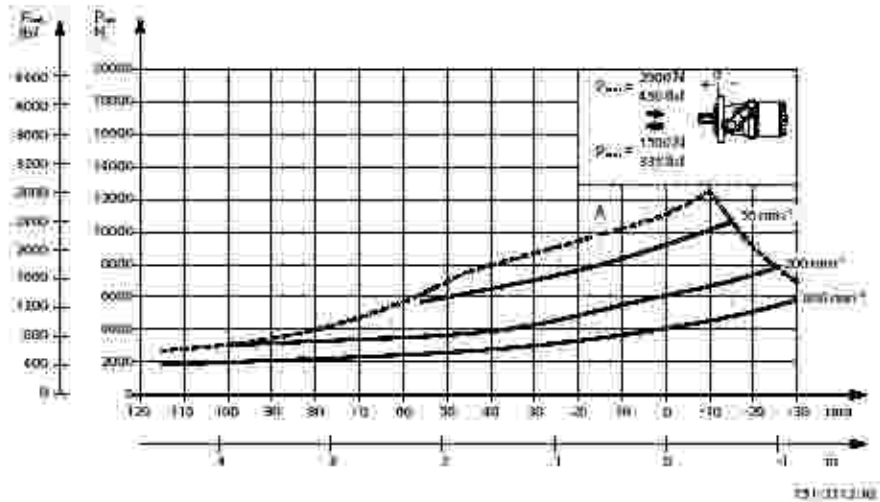

The output shaft on OMP N can be offered in needle bearings. These bearings and the recessed mounting flange allow a higher permissible radial load in comparison to OMP motors.

The permissible radial load on the shaft is shown for different speeds as a function of the distance from the mounting flange to the point of load application.

Curve A indicates the max. radial shaft load. Any shaft load exceeding the values quoted in curve A will involve risk of breakage.

The other curves apply to a B10 bearing life of 2000 hours at the number of revolutions indicated by the curve letter. Mineral based hydraulic oil with a sufficient content of anti-wear additives must be used.

Bearing life calculations can be made using the explanation and formula provided in the chapter "Bearing dimensioning" in the technical information "General Orbital Motors" 520L0232 Rev. B.

Permissible Shaft Load  
 for OMPW with Slide  
 Bearings

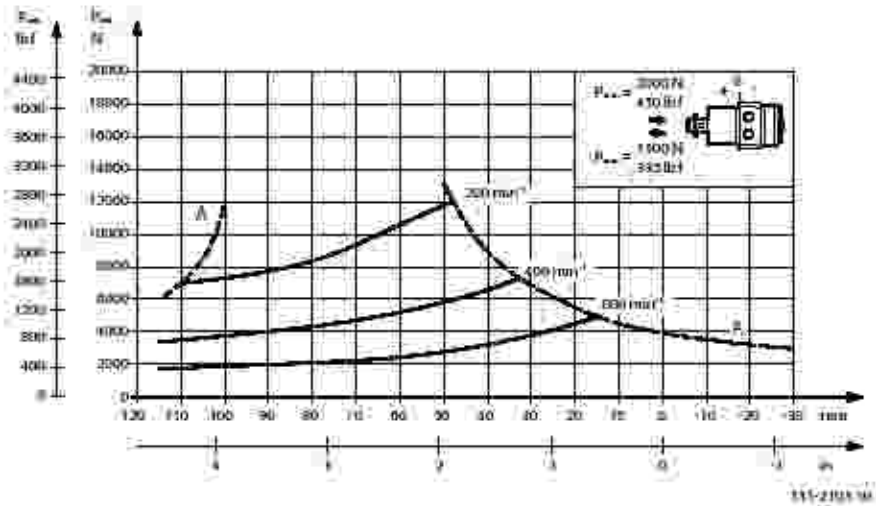

The output shaft on OMPW can be offered in slide bearings similar to the other OMP-motors. The permissible higher radial load is therefore due to the recessed mounting flange moving the point of load closer to the motor bearings.

The permissible radial load on the shaft is shown for different speeds as a function of the distance from the mounting flange to the point of load application.

The curves are not based on calculations of B10 bearing life. They represent absolute limits that must not be exceeded.

Curve A indicates the max. radial shaft load. Any shaft load exceeding the values quoted in curve A will involve risk of breakage.

Permissible Shaft Load  
 for OMPW N with Needle  
 Bearing

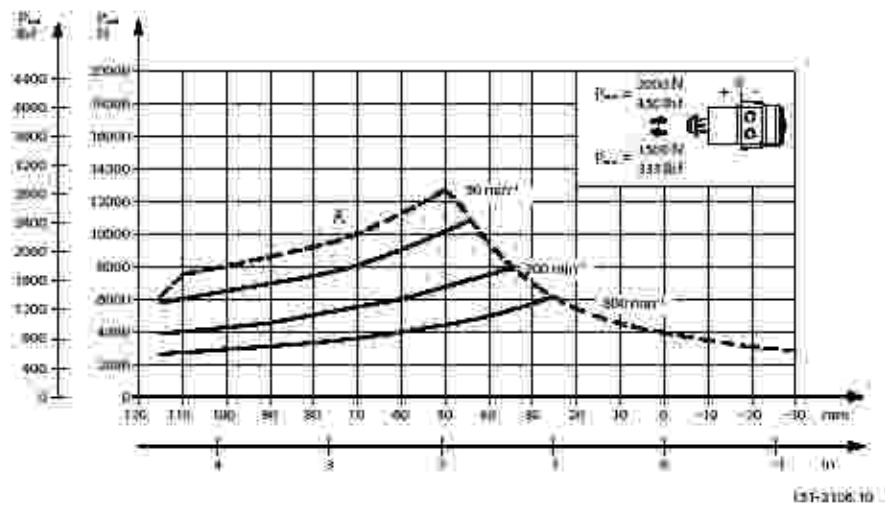

The output shaft on OMPW N can be offered in needle bearings. These bearings and the recessed mounting flange allow a higher permissible radial load in comparison to OMP motors.

The permissible radial load on the shaft is shown for different speeds as a function of the distance from the mounting flange to the point of load application.

Curve A indicates the max. radial shaft load. Any shaft load exceeding the values quoted in curve A will involve risk of breakage.

The other curves apply to a B10 bearing life of 2000 hours at the number of revolutions indicated by the curve letter. Mineral based hydraulic oil with a sufficient content of anti-wear additives must be used.

Bearing life calculations can be made using the explanation and formula provided in the chapter "Bearing dimensioning" in the technical information "General Orbital Motors" 520L0232 Rev. B.

Function Diagrams

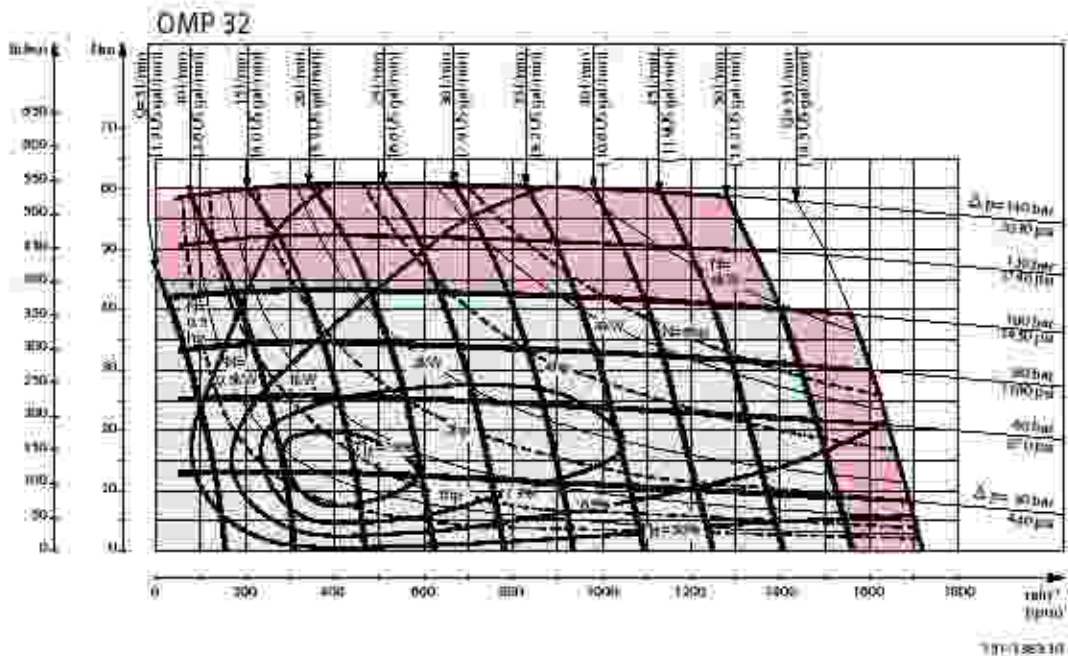
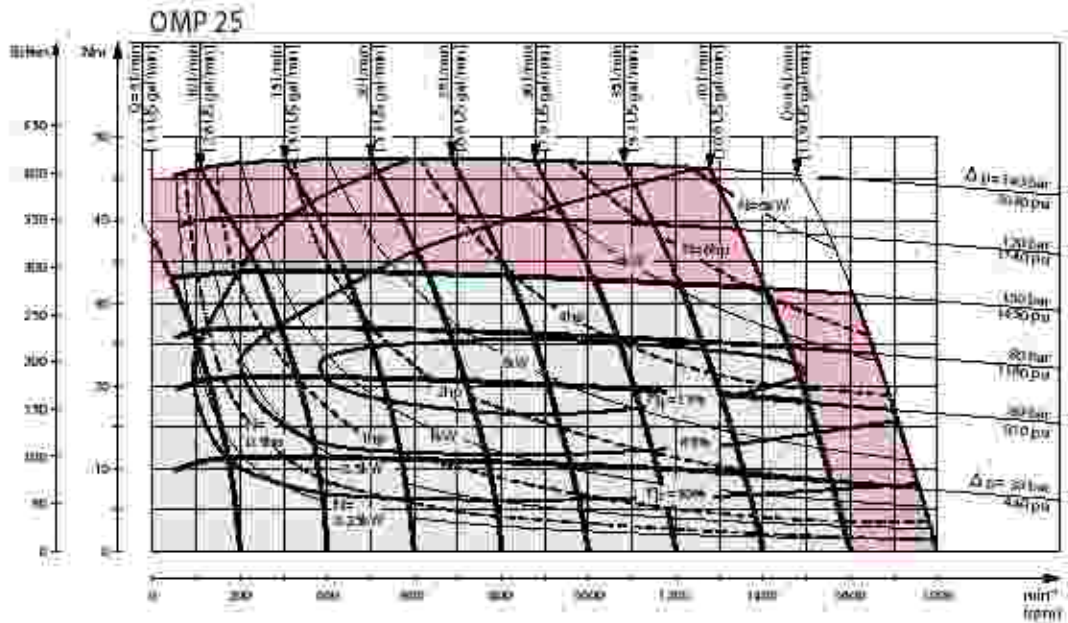

Explanation of function diagram use, basis and conditions can be found on page 7.

Continuous range

Intermittent range (max. 10% operation every minute)

Max. permissible continuous/intermittent pressure drop for the actual shaft version can be found on page 10-13.

Intermittent pressure drop and oil flow must not occur simultaneously

Function Diagrams

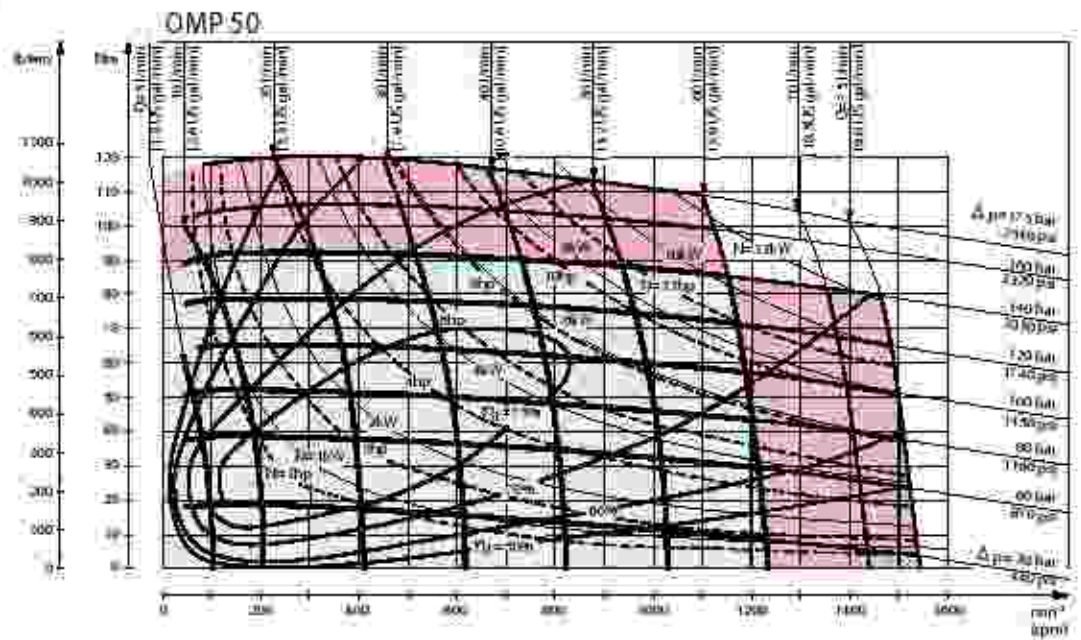
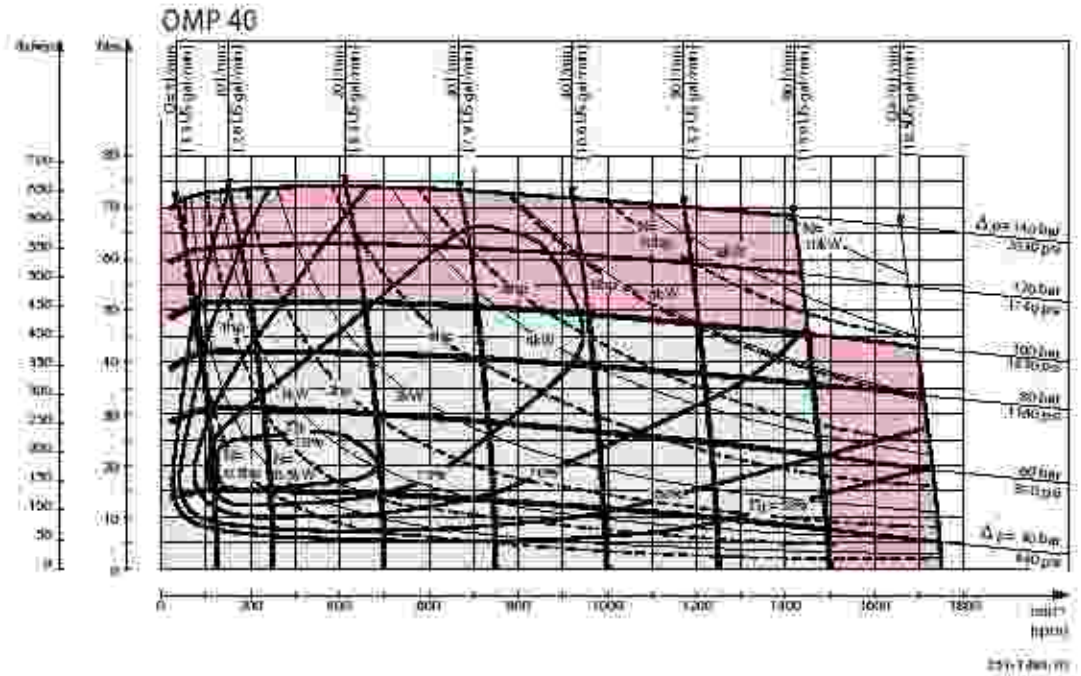

Explanation of function diagram use, basis and conditions can be found on page 7.

Continuous range

Intermittent range (max. 10% operation every minute)

Max. permissible continuous/intermittent pressure drop for the actual shaft version can be found on page 10-13.

Intermittent pressure drop and oil flow must not occur simultaneously.

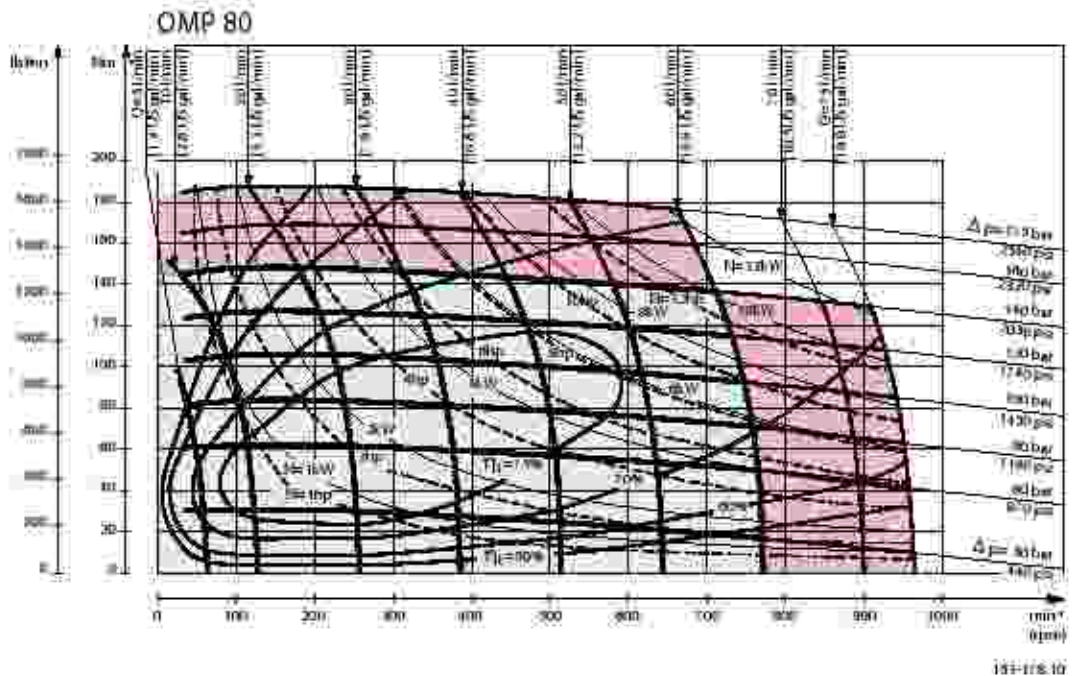

Explanation of function diagram use, basis and conditions can be found on page 7.

Continuous range

Intermittent range (max. 10% operation every minute)

Max. permissible continuous/intermittent pressure drop for the actual shaft version can be found on page 10-13.

Intermittent pressure drop and oil flow must not occur simultaneously

Function Diagrams

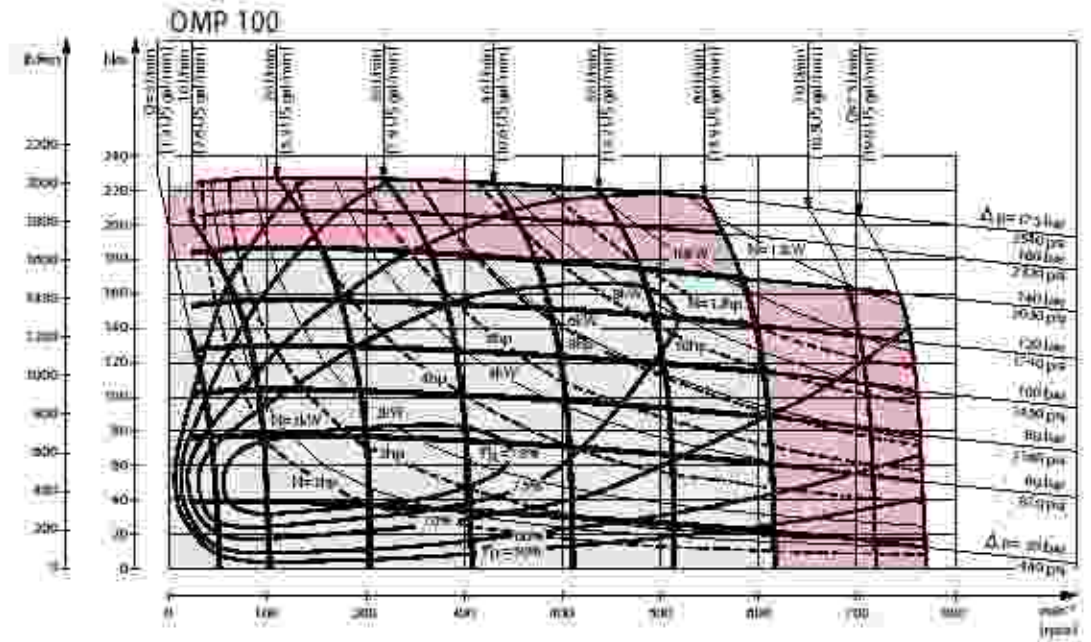

131-108 00

OMP 110  
 under preparation

Explanation of function diagram use, basis and conditions can be found on page 7.

Continuous range

Intermittent range (max. 10% operation every minute)

Max. permissible continuous/intermittent pressure drop for the actual shaft version can be found on page 10-13.

Intermittent pressure drop and oil flow must not occur simultaneously.

Function Diagrams

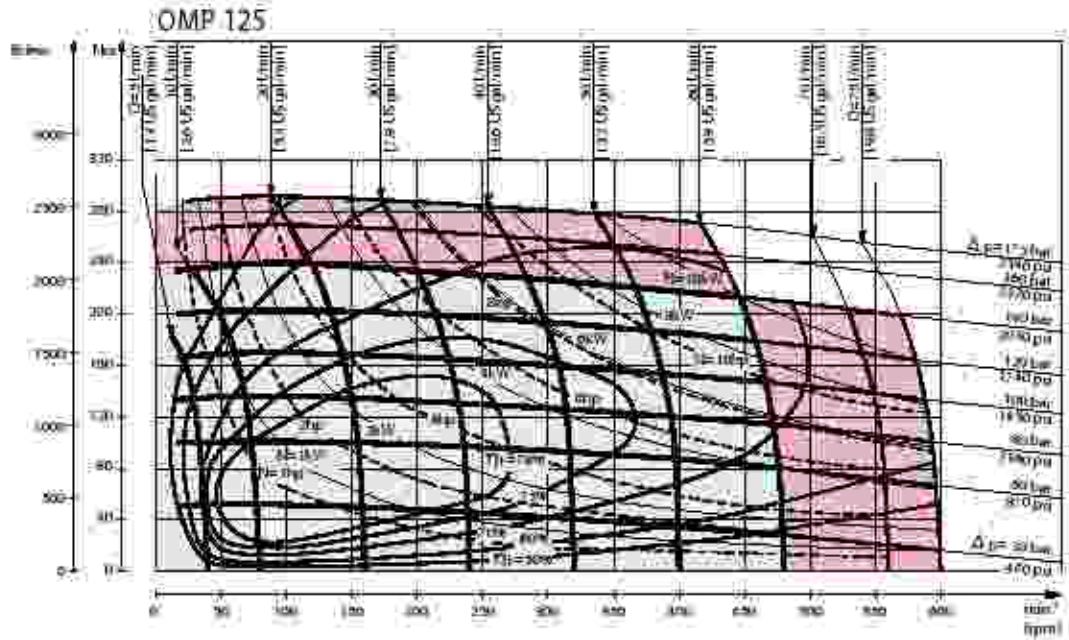

151-1438.10

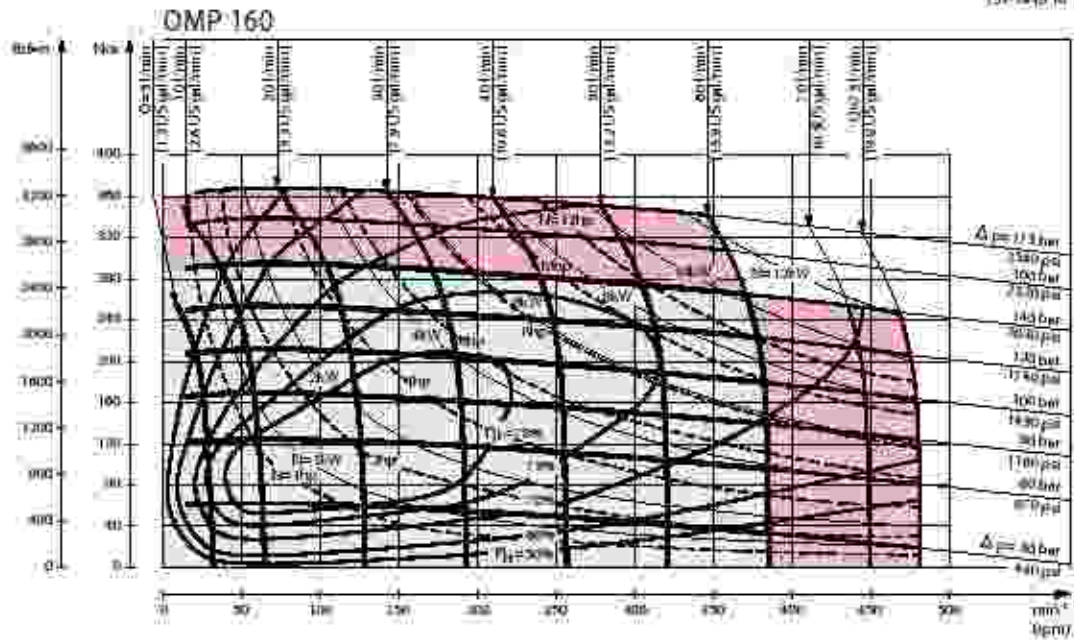

151-160.10

Explanation of function diagram use, basis and conditions can be found on page 7.

Continuous range

Intermittent range (max. 10% operation every minute)

Max. permissible continuous/intermittent pressure drop for the actual shaft version can be found on page 10-13.

Intermittent pressure drop and oil flow must not occur simultaneously



Function Diagrams

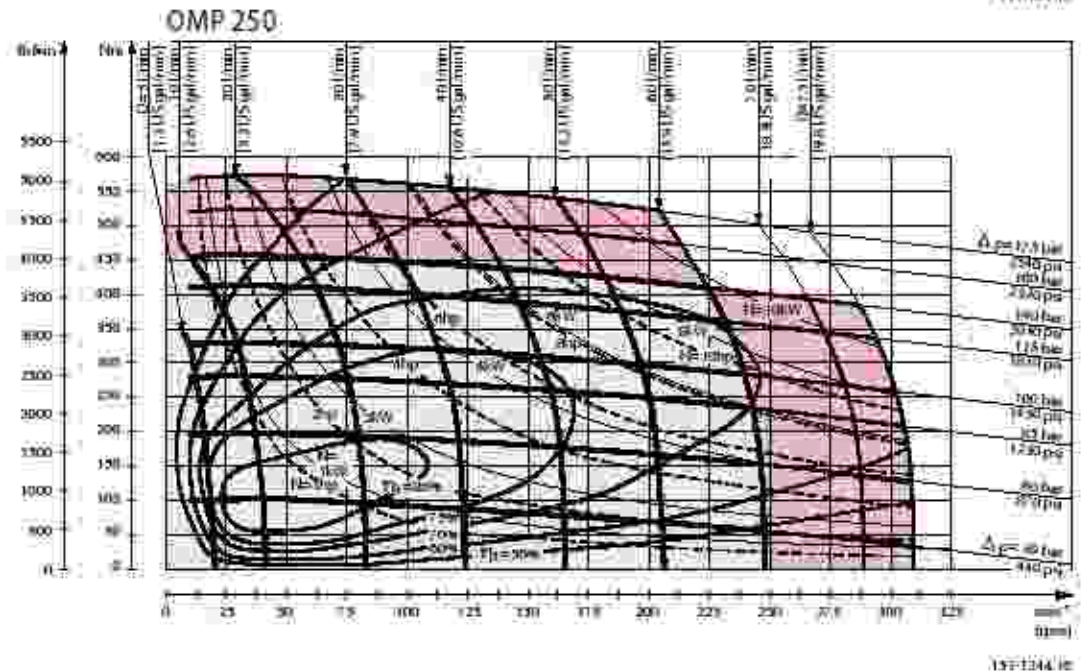
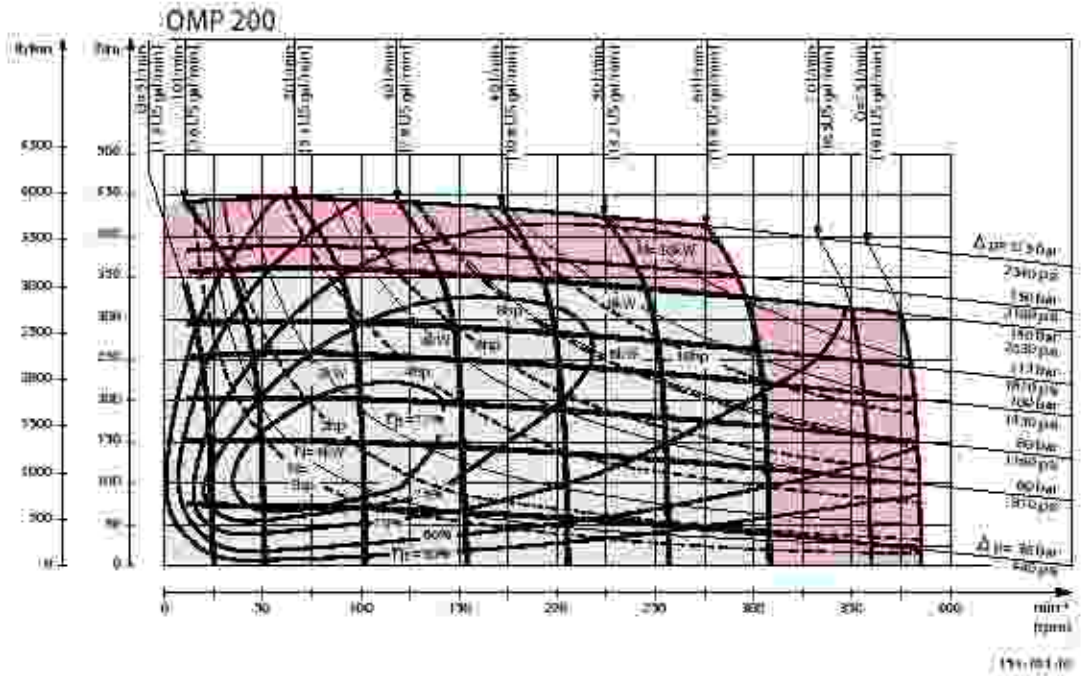

Explanation of function diagram use, basis and conditions can be found on page 7.

Continuous range

Intermittent range (max. 10% operation every minute)

Max. permissible continuous/intermittent pressure drop for the actual shaft version can be found on page 10-13.

Intermittent pressure drop and oil flow must not occur simultaneously.

Function Diagrams

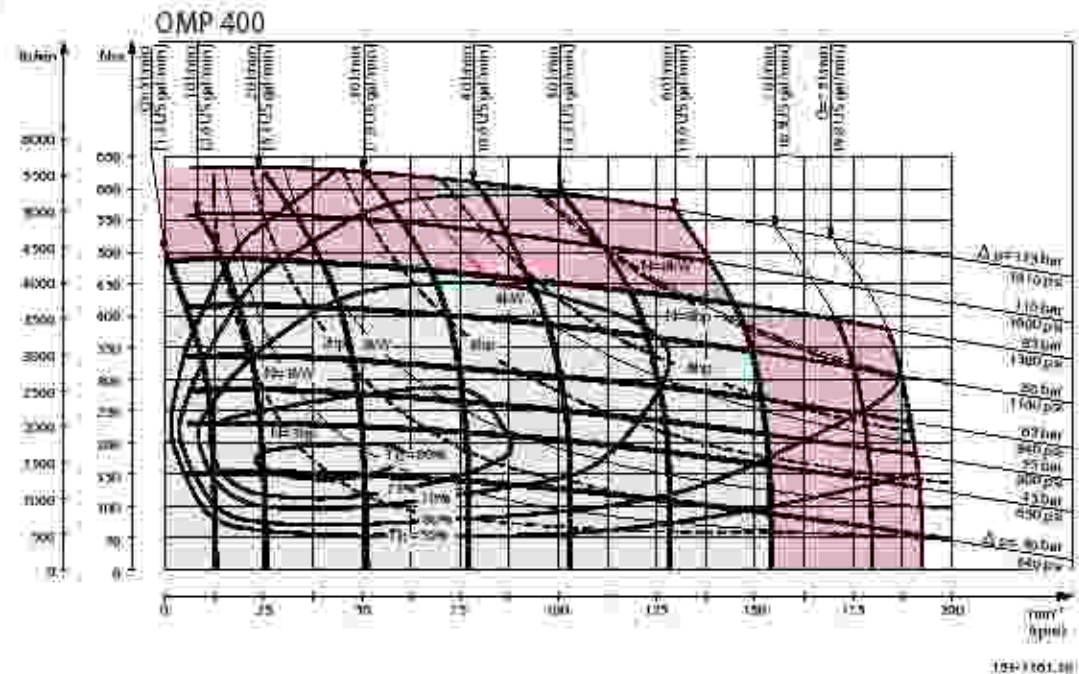
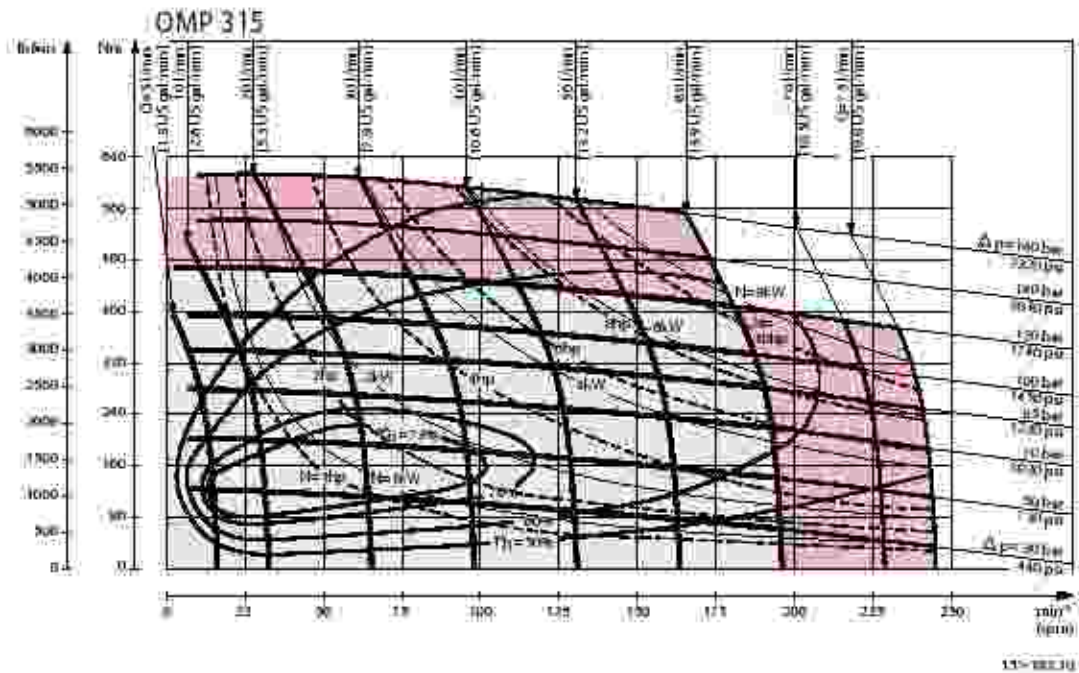

Explanation of function diagram use, basis and conditions can be found on page 7.

Continuous range

Intermittent range (max. 10% operation every minute)

Max. permissible continuous/intermittent pressure drop for the actual shaft version can be found on page 10-13.

Intermittent pressure drop and oil flow must not occur simultaneously

**Shaft Version**

- A: Cylindrical shaft  
 25 mm  
 D: Parallel key  
 AB-7-32  
 DIN 6885

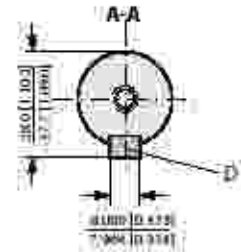
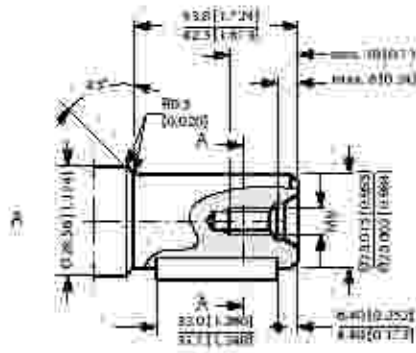

- B: Cylindrical shaft  
 1 in  
 E: Parallel key  
 1/4 x 1/4 x 1 1/4 in  
 B.S. 46

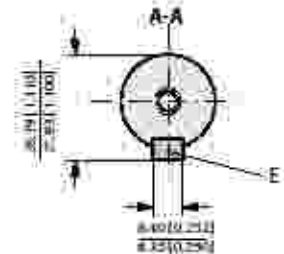
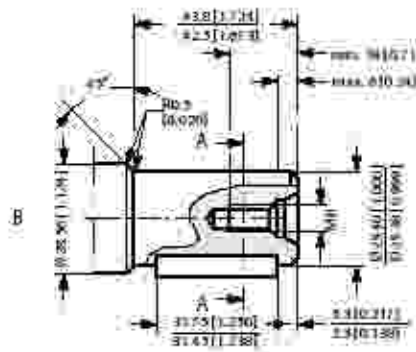

**US version**

- C: Cylindrical shaft  
 1 in  
 E: Parallel key  
 1/4 x 1/4 x 1 1/4 in  
 B.S. 46

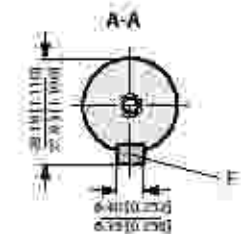
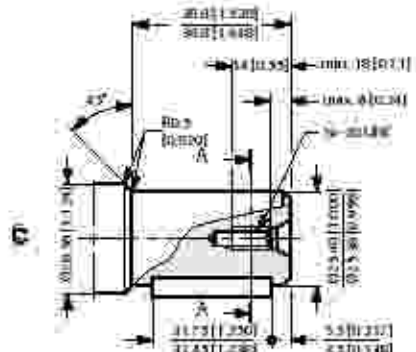

Shaft Version

- D: Cylindrical shaft 32 mm
- I: Parallel key
- A 10 - 6 - 45
- DIN 6885

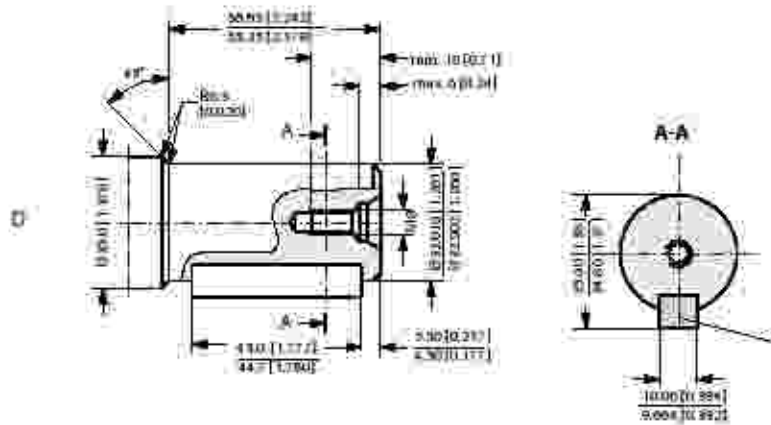

- E: Splined shaft
- B.S. 2059 (SAE 6B)
- Straight-sided
- bottom fitting, dep
- Fit 2
- Nom. size 1.00
- \* Deviates from
- BS 2059 (SAE 6B)

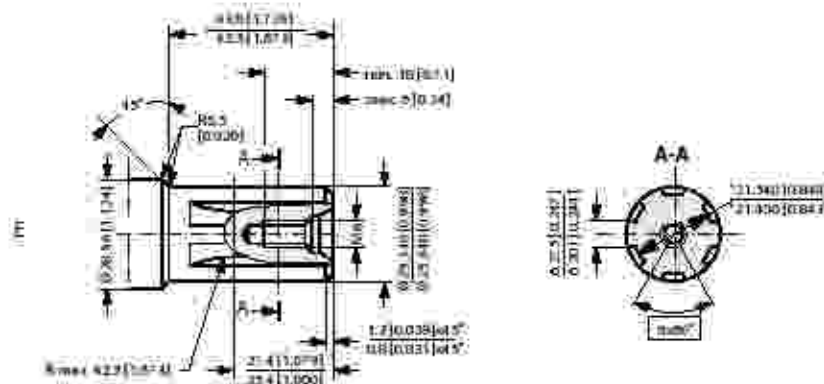

- F: Tapered shaft
- H: DIN 937
- NV 30
- Tightening torque:
- 100 ± 10 N·m [985 ± 88.50 lbf·in]
- G: Taper 1:10
- J: Parallel key
- B5 - 5 - 14
- DIN 6885

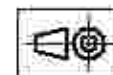
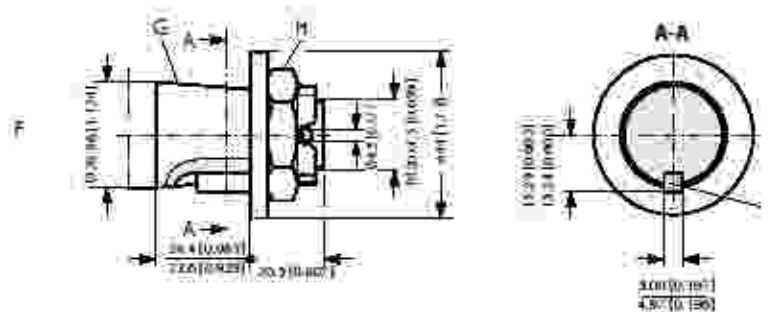

175-1087-11

Port Thread Versions

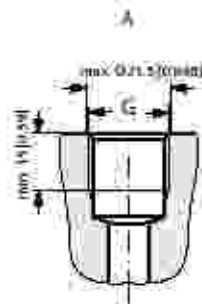

A: G main ports  
 G: ISO 228/1 - G 1/2

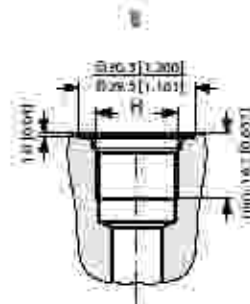

B: UNF main ports  
 H: 1/8 - 14 UNF  
 O-ring boss port



C: NPTF main ports  
 K: 1/2 - 14 NPTF

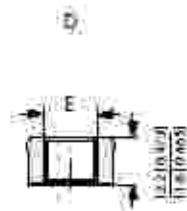

D: G drain port  
 E: ISO 228/1 - G 1/4



F: UNF drain port  
 J: 1/8 - 20 UNF  
 O-ring boss port

131-2884-11

Manifold Mount

European version

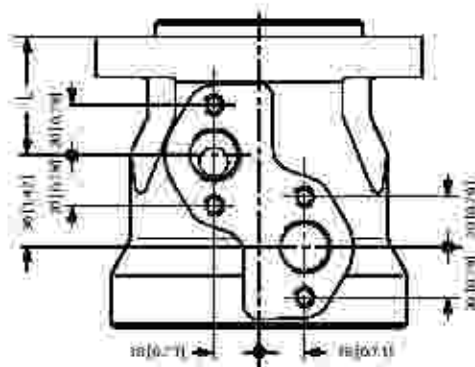

131-2885-10

L: see dimensional drawing for given OMP motor on pages 30 - 38.

**Dimensions**

Side port version with 2 hole oval mounting flange (A2-flange).

Type	Max. L, mm [in]	L, mm [in]
OMP 25	130.0 [5.12]	4.1 [0.16]
OMP 32	131.0 [5.16]	5.2 [0.20]
OMP 40	132.0 [5.20]	6.3 [0.26]
OMP 50	132.0 [5.20]	6.3 [0.26]
OMP 80	130.0 [5.35]	10.4 [0.41]
OMP 100	138.5 [5.45]	13.0 [0.51]
OMP 125	142.0 [5.59]	16.7 [0.66]
OMP 160	146.5 [5.77]	20.8 [0.82]
OMP 200	151.5 [5.96]	26.0 [1.02]
OMP 250	158.0 [6.22]	32.5 [1.28]
OMP 315	166.5 [6.56]	40.9 [1.61]
OMP 400	177.6 [6.99]	52.0 [2.05]

D: G 1/2, 13 mm [0.51 in] deep  
E: M8, 13 mm [0.51 in] deep  
+ pcs.)

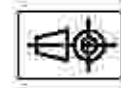
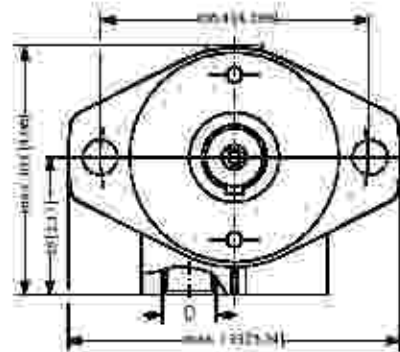
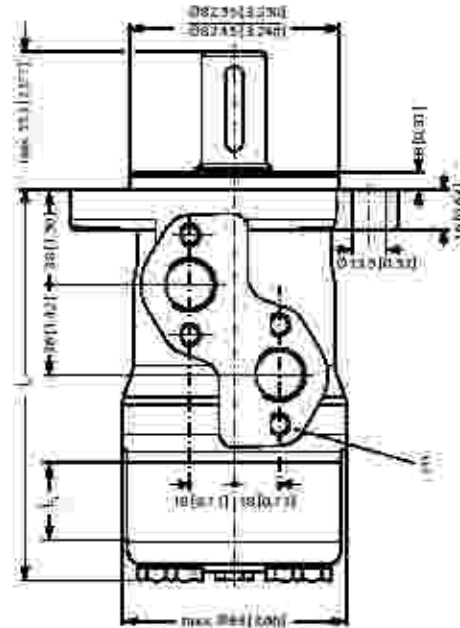

135-0000-10

**Dimensions**

5/8 port version with 2 hole oval mounting flange (A2-flange)  
 With drain connection.

Type	Max. L mm [in]	L mm [in]
OMP 25	130.0 [5.12]	4.1 [0.16]
OMP 32	131.0 [5.16]	5.2 [0.20]
OMP 40	132.0 [5.20]	6.3 [0.25]
OMP 50	132.0 [5.20]	6.3 [0.25]
OMP 80	136.0 [5.35]	10.4 [0.41]
OMP 100	138.5 [5.45]	13.0 [0.51]
OMP 125	142.0 [5.59]	16.7 [0.66]
OMP 160	146.5 [5.77]	20.8 [0.82]
OMP 200	151.5 [5.96]	26.0 [1.02]
OMP 250	158.0 [6.22]	32.5 [1.28]
OMP 315	166.5 [6.56]	40.9 [1.61]
OMP 400	177.6 [6.99]	52.0 [2.05]

- C: Drain connection  
 G<sub>1/4</sub>, 12 mm [0.47 in] deep
- D: G<sub>1/4</sub>, 15 mm [0.59 in] deep
- E: M6, 13 mm [0.51 in] deep  
 (4 pcs.)

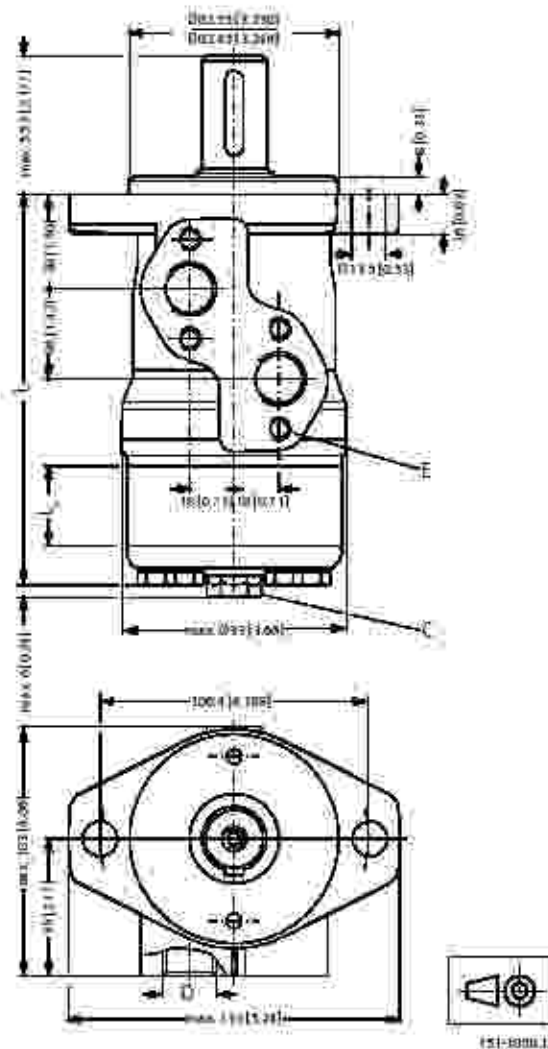

**Dimensions**

OMP C and OMP N  
 Side port version with 2 hole oval mounting flange (A2-flange)

Type	Max. L mm [in]	L mm [in]
OMP 50	132.0 [5.20]	6.3 [0.26]
OMP 80	136.0 [5.35]	10.4 [0.41]
OMP 100	138.5 [5.45]	13.0 [0.51]
OMP 125	142.0 [5.59]	16.7 [0.66]
OMP 160	146.5 [5.77]	20.8 [0.82]
OMP 200	151.5 [5.97]	26.0 [1.02]
OMP 250	158.0 [6.22]	32.5 [1.28]
OMP 315	166.5 [6.56]	40.0 [1.61]
OMP 400	177.6 [6.99]	52.0 [2.05]

- C: Drain connection  
 G<sub>1/2</sub>: 12 mm [0.47 in] deep
- D: G<sub>1/2</sub>: 15 mm [0.59 in] deep
- E: M8: 13 mm [0.51 in] deep  
 (4 pcs.)

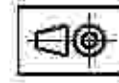
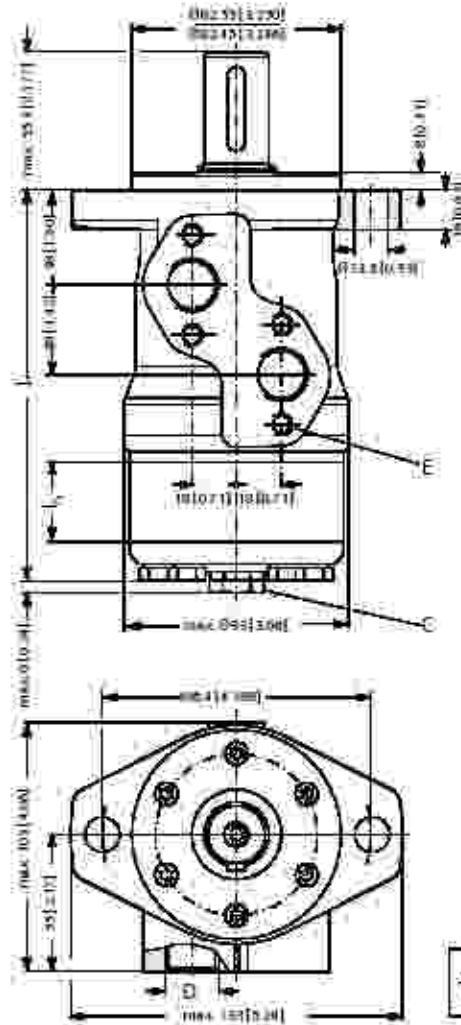

355-1047.12



**Dimensions**

End part version with 2 hole oval mounting flange (A2-flange)

Type	Max. L, mm [in]	L, mm [in]
OMP 50	146.1 [5.75]	6.5 [0.26]
OMP 80	150.0 [5.91]	10.4 [0.41]
OMP 100	152.7 [6.01]	13.0 [0.51]
OMP 125	156.2 [6.15]	16.7 [0.66]
OMP 160	160.4 [6.32]	20.8 [0.82]
OMP 200	165.6 [6.52]	26.0 [1.02]
OMP 250	172.1 [6.78]	32.5 [1.28]
OMP 315	180.5 [7.11]	40.9 [1.61]
OMP 400	191.6 [7.54]	52.0 [2.05]

- Drain connection
- G<sub>1/4</sub>; 12 mm [0.47 in] deep
- G<sub>1/2</sub>; 15 mm [0.59 in] deep

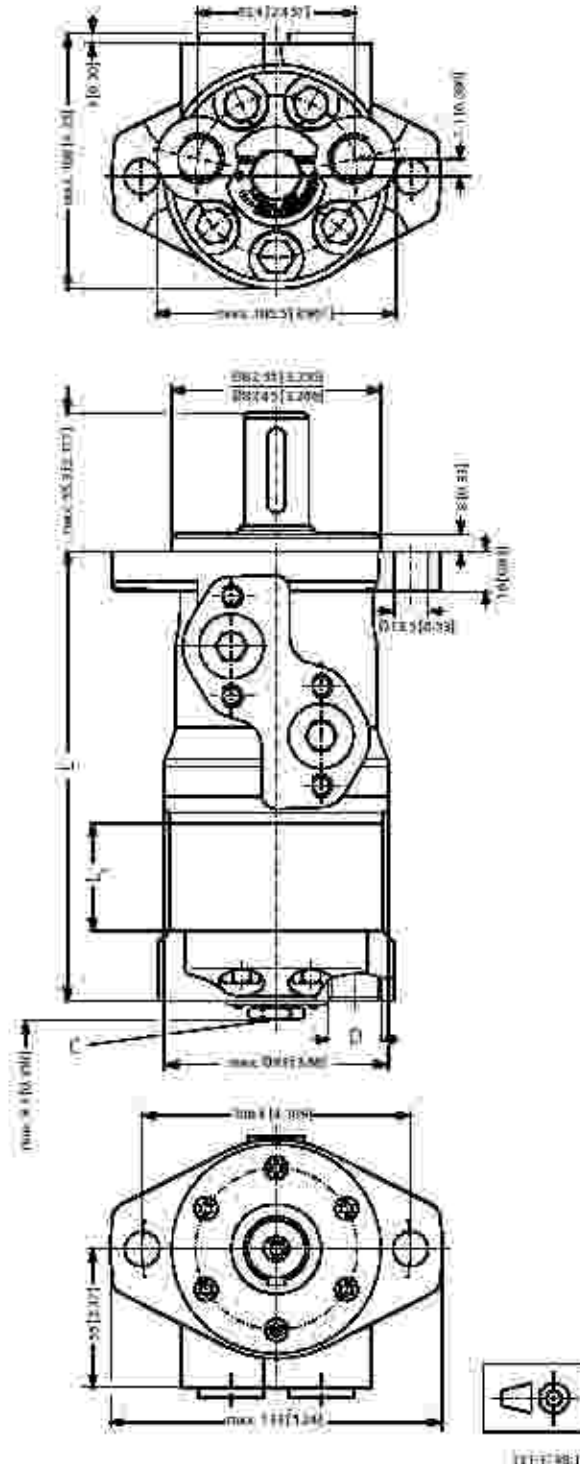

**Dimensions**

Side port version with 2 hole oval mounting flange (A2-flange).

Type	Max. L mm [in]	L mm [in]
OMP 25	130.0 [5.35]	4.1 [0.16]
OMP 32	137.0 [5.39]	5.2 [0.20]
OMP 40	138.0 [5.43]	6.3 [0.26]
OMP 50	139.0 [5.43]	6.3 [0.26]
OMP 80	142.0 [5.59]	10.4 [0.41]
OMP 100	144.5 [5.69]	13.0 [0.51]
OMP 125	148.0 [5.83]	16.7 [0.66]
OMP 160	152.5 [6.00]	20.8 [0.82]
OMP 200	157.5 [6.20]	26.0 [1.02]
OMP 250	164.0 [6.46]	32.5 [1.28]
OMP 315	172.5 [6.79]	40.9 [1.61]
OMP 400	183.6 [7.23]	52.0 [2.05]

- C: Drain connection  
 G<sup>7/8</sup> UNF  
 12 mm (0.47 in) deep
- D: G<sup>7/8</sup> - 14 UNF  
 16.7 mm (0.66 in) deep
- E: M8; 13 mm (0.51 in) deep  
 (4 pcs.)

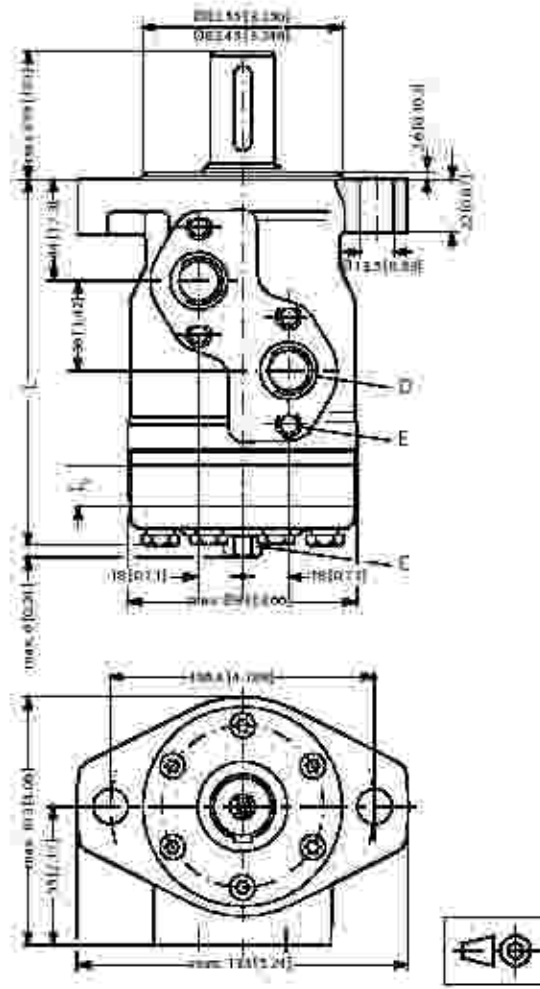

991-1200-71

**Dimensions**

Side port version with 4 hole oval mounting flange (A4-flange)

Type	Max. L, mm [in]	L, mm [in]
OMP 50	132.0 [5.20]	6.5 [0.26]
OMP 80	136.0 [5.35]	10.4 [0.41]
OMP 100	138.5 [5.45]	13.0 [0.51]
OMP 125	142.0 [5.59]	16.7 [0.66]
OMP 160	146.5 [5.77]	20.8 [0.82]
OMP 200	151.5 [5.97]	26.0 [1.02]
OMP 250	158.0 [6.22]	32.5 [1.28]
OMP 315	166.5 [6.56]	40.9 [1.61]
OMP 400	177.6 [6.99]	52.0 [2.05]

- Drain connection
- G 1/4; 12 mm [0.47 in] deep
- D; G 1/2; 15 mm [0.59 in] deep
- E; M8; 13 mm [0.51 in] deep  
(4 pcs.)

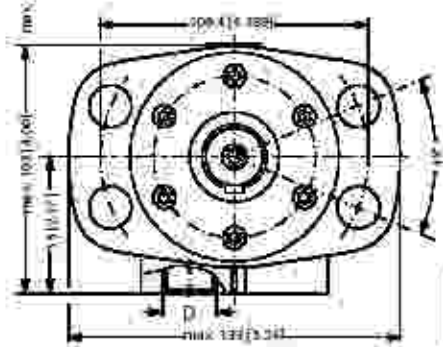
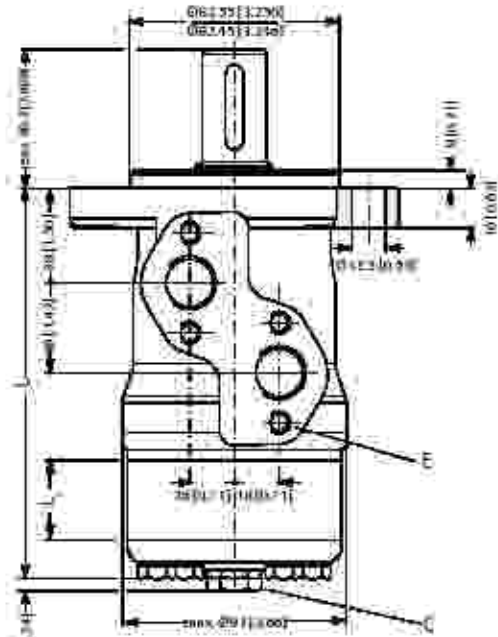

**Dimensions**

End port version with square mounting flange (C-flange)

Type	Max. L mm [in]	L mm [in]
OMP 50	132.0 [5.98]	6.3 [0.26]
OMP 80	156.0 [6.14]	10.4 [0.41]
OMP 100	158.0 [6.24]	13.0 [0.51]
OMP 125	162.1 [6.38]	16.7 [0.66]
OMP 160	166.4 [6.55]	20.8 [0.82]
OMP 200	171.6 [6.76]	26.0 [1.02]
OMP 250	176.1 [7.01]	32.3 [1.28]
OMP 315	190.5 [7.54]	40.0 [1.61]
OMP 400	197.6 [7.78]	52.0 [2.05]

C: Drain connection

G<sub>1/4</sub>: 12 mm [0.47 in] deep

D: G<sub>3/8</sub>: 18 mm [0.71 in] deep

E: M10: 15 mm [0.59 in] deep  
 (4 pcs)

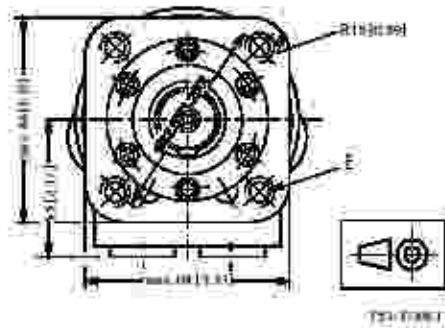
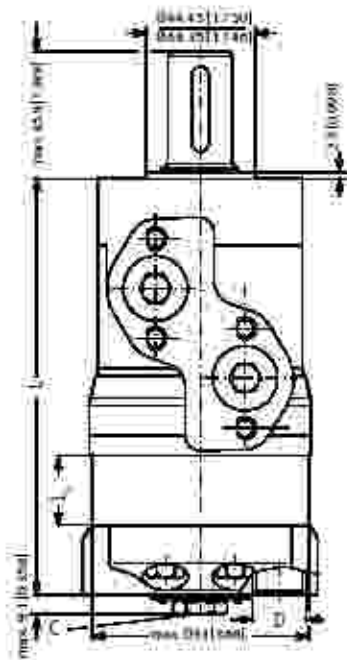

**Dimensions**

*Safe port version with square mounting flange (C-flange).*

Type	Max. L, mm [in]	L, mm [in]
OMP 50	132.0 [5.20]	6.5 [0.26]
OMP 80	136.0 [5.35]	10.4 [0.41]
OMP 100	138.5 [5.45]	13.0 [0.51]
OMP 125	142.0 [5.59]	16.7 [0.66]
OMP 160	146.5 [5.77]	20.8 [0.82]
OMP 200	151.5 [5.97]	26.0 [1.02]
OMP 250	158.0 [6.22]	32.5 [1.28]
OMP 315	166.5 [6.56]	40.9 [1.61]
OMP 400	177.6 [6.99]	52.0 [2.05]

- C Drain connection:  
 7/8" - 20 UNF,  
 12 mm [0.47 in] deep
- D: 7/8" - 14 UNF,  
 16.76 mm [0.66 in] deep,  
 or 1/2" - 14 NPTF
- E: 7/8" - 16 UNC,  
 15 mm [0.59 in] deep  
 (4 off)
- F: M6: 13 mm [0.51 in] deep  
 (4 pcs.)

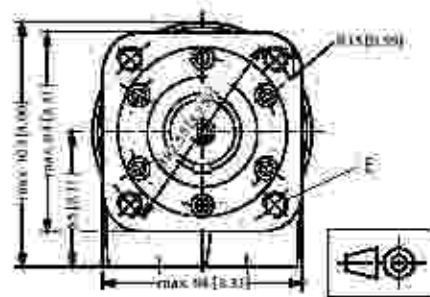
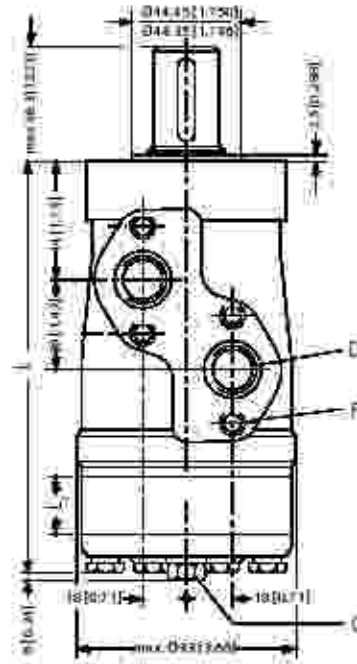

TR31248-10

**Dimensions**

*OMPW and OMPW N wheel motor*

Output shaft max.	mm L [in]
Cylindrical shaft 25 mm [0.98 in]	max. 115 [4.53]
Tapered shaft 28.56 mm [1.12 in]	max. 117.8 [4.64]

Type	Max. L mm [in]	L mm [in]
OMP 50	71.9 [2.83]	5.5 [0.26]
OMP 80	75.7 [2.98]	10.4 [0.41]
OMP 100	78.3 [3.08]	13.0 [0.51]
OMP 125	81.6 [3.21]	16.7 [0.66]
OMP 160	86.1 [3.39]	20.8 [0.82]
OMP 200	91.3 [3.60]	26.0 [1.02]
OMP 250	97.8 [3.85]	32.5 [1.28]
OMP 315	106.2 [4.18]	40.9 [1.61]
OMP 400	117.3 [4.62]	52.0 [2.05]

- C: Drain connection  
G ¼, 12 mm [0.47 in] deep
- D: G ½, 15 mm [0.59 in] deep
- E: M10, 20 mm [0.79 in] deep  
(4 pcs.)

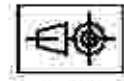
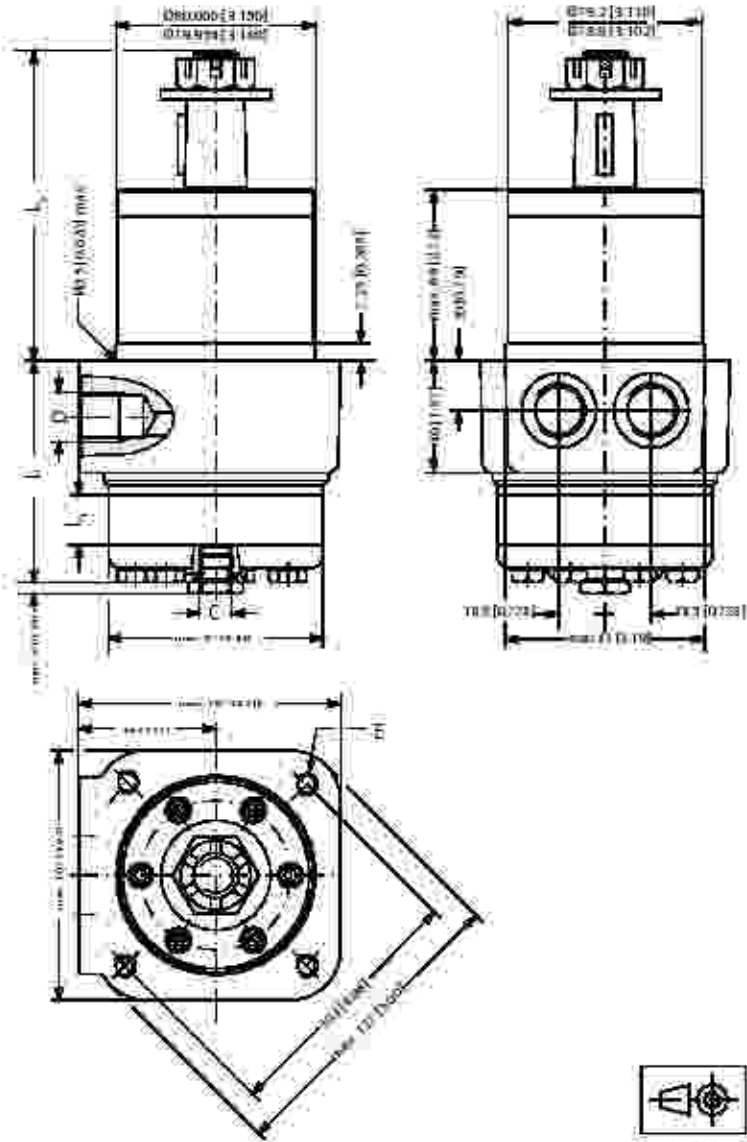

103-E360-01



OMP  
Technical Information  
Notes

Notes:

VERSIONS

Mounting flange	Spigot diameter (front / rear end)	Flange circle diameter (BC)	Shaft	Port size	European version	US version	Side port version	End port version	Flange port version	Standard shaft seal	High pressure shaft seal	Drain connection	Check valve	Main type designation		
2 hole oval flange (A2-flange)	Ø 82.5 mm [3.25 in]	Ø 106.4 mm [4.20 in]	Cyl. 25 mm	G 1/2	●		●				●	No	No	OMR		
				G 3/8	●		●				●	Yes	Yes	OMR		
				G 1/4	●			●			●	Yes	Yes	OMR		
			Cyl. 1 inch			G 3/8	●		●				●	No	No	OMR
						G 1/4	●		●				●	Yes	Yes	OMR
						7/8-14 UNF		●	●				●	Yes	Yes	OMR
			Spooled 1 inch			G 3/8	●		●				●	No	No	OMR
						G 1/4	●		●				●	Yes	Yes	OMR
						7/8-14 UNF		●	●				●	Yes	Yes	OMR
			Cyl. 32 mm			G 1/2	●		●			●		Yes	Yes	OMR
G 3/8	●					●			●		Yes	Yes	OMR			
4 hole oval flange (A4-flange)	Ø 82.5 mm [3.25 in]	Ø 106.4 mm [4.20 in]	Cyl. 25 mm	G 1/2	●		●			●		Yes	Yes	OMR		
			Cyl. 32 mm	G 1/2	●		●			●		Yes	Yes	OMR		
			Cyl. 1 1/4 in	7/8-14 UNF		●	●			●		Yes	Yes	OMR		
Square flange (C-flange)	Ø 44.4 mm [1.75 in]	Ø 82.5 mm [3.25 in]	Cyl. 25 mm	G 1/2	●			●		●		Yes	Yes	OMR		
			Cyl. 1 in	7/8-14 UNF		●	●			●		Yes	Yes	OMR		

OMR motors with corrosion resistant parts

2 hole oval flange (A2-flange)	Ø 82.5 mm [3.25 in]	Ø 106.4 mm [4.20 in]	Cyl. 25 mm	G 1/2	●		●			●		Yes	Yes	OMR.C
--------------------------------	---------------------	----------------------	------------	-------	---	--	---	--	--	---	--	-----	-----	-------

OMR motors with needle bearings

2 hole oval flange (A2-flange)	Ø 82.5 mm [3.25 in]	Ø 106.4 mm [4.20 in]	Cyl. 25 mm	G 1/2	●		●			●		Yes	Yes	OMR.N
Wheel	Ø 82.5 mm [3.25 in]	Ø 147.6 mm [5.81 in]	Tap. 35 mm	G 1/2	●				●	●		Yes	Yes	OMR.W.N
			Tap. 1 1/4 in	7/8-14 UNF		●	●			●	●		Yes	Yes

OMR motors with integrated brake

2 hole oval flange (A2-flange)	Ø 82.5 mm [3.25 in]	Ø 106.4 mm [4.20 in]	Cyl. 25 mm	G 1/2	●		●			●		Yes	Yes	OMR.F
--------------------------------	---------------------	----------------------	------------	-------	---	--	---	--	--	---	--	-----	-----	-------

OMR motors with integrated brake and needle bearings

2 hole oval flange (A2-flange)	Ø 82.5 mm [3.25 in]	Ø 106.4 mm [4.20 in]	Cyl. 1 in	7/8-14 UNF		●	●			●		Yes	Yes	OMR.NF
Wheel	Ø 82.5 mm [3.25 in]	Ø 147.6 mm [5.81 in]	Tap. 35 mm	G 1/2	●				●	●		Yes	Yes	OMR.W.NF

Functions diagram - see page →

Features available options:

Low leakage (low speed valve)      Reverse rotation  
Speed sensor      Painted  
Viton shaft seal



Code Numbers

Code numbers	Displacement (cm <sup>3</sup> )									Technical data - Page	Dimensions - Page
	50	80	100	125	160	200	250	315	375		
151-	0410	0411	0412	0413	0414	0415	0416	0417	0418	42	61
151-	0710	0711	0712	0713	0714	0715	0716	0717	0718	42	62
151-	6190	6191	6192	6193	6194	6195	6196	6197	6198	42	64
151-	0400	0401	0402	0403	0404	0405	0406	0407	0408	42	61
151-	0700	0701	0702	0703	0704	0705	0706	0707	0708	42	62
151-	7240	7241	7242	7243	7244	7245	7246	7247	7248	42	65
151-	0420	0421	0422	0423	0424	0425	0426	0427	0428	43	61
151-	0720	0721	0722	0723	0724	0725	0726	0727	0728	43	62
151-	7250	7251	7252	7253	7254	7255	7256	7257	7258	43	65
151-	0248	0249	0243	0208	0244	0245	0247	0246	0204	44	63
151-	0265	0266	0267	0295	0268	0269	0271	0270	0290	43	63
151-	6010	6011	6012	6013	6014	6015	6016	6017	6018	42	66
151-	6000	6001	6002	6003	6004	6005	6006	6007	6008	44	66
151-	6110	6111	6112	6113	6114	6115	6116	6117	6118	44	67
151-	6210	6211	6212	6213	6214	6215	6216	6217	6218	42	68
151-	7260	7261	7262	7263	7264	7265	7266	7267	7269	42	66
<b>OMR motors with corrosion resistant parts</b>											
151-	1231	1232	1233	1238	1234	1235	1236	1237	1243	42	63
<b>OMR motors with needle bearings</b>											
151-	6380	6381	-	6383	6384	6385	6386	6387	6388	42	63
151-	6300	6301	6302	6303	6304	6305	6306	6307	6308	44	70
151-	6430	6431	6432	6433	6434	6435	6436	6437	6438	44	71
<b>OMR motors with integrated brake</b>											
151-	-	6461	6462	6463	6464	6465	6466	6467	6468	42	72
<b>OMR motors with integrated brake and needle bearings</b>											
151-	-	6471	6472	6473	6474	6475	6476	6477	6478	42	73
151-	-	-	6442	6443	6444	6445	-	-	-	44	74
→	51	51	52	52	53	53	54	54	55		

**Ordering**  
Add the four digit prefix "151-" to the four digit numbers from the chart for complete code number.

**Example:**  
151-6004 for an OMR 160 with A4-flange, cyl. 32 mm shaft, port size G 1/2 and side port version.

Orders will not be accepted without the four digit prefix.

Technical data for OMR with 25 mm and 1 in cylindrical shaft

Type		OM1	OM2	OMR	OMR	OM1	OMR	OMR	OM1		
Motor size		50	80	100	125	160	200	250	315	375	
Geometric displacement	cm <sup>3</sup> [inch <sup>3</sup> ]	51.6 [3.16]	80.3 [4.91]	99.8 [6.11]	125.7 [7.69]	159.6 [9.77]	199.8 [12.23]	249.3 [15.26]	315.7 [19.31]	372.6 [22.80]	
Max. speed	min <sup>-1</sup> [rpm]	cont.	775	750	680	475	375	300	240	190	160
		int. <sup>1)</sup>	970	940	750	600	470	375	300	240	200
Max. torque	N·m [lbf·in]	cont.	100 [890]	195 [1730]	240 [2110]	300 [2680]	300 [2680]	300 [2680]	300 [2680]	300 [2680]	300 [2680]
		int. <sup>1)</sup>	130 [1150]	220 [1960]	280 [2480]	340 [3010]	390 [3450]	390 [3450]	380 [3360]	420 [3720]	430 [3810]
		peak <sup>2)</sup>	170 [1510]	270 [2390]	320 [2830]	370 [3280]	460 [4070]	560 [4960]	600 [5310]	610 [5400]	600 [5310]
Max. output	kW [hp]	cont.	7.0 [9.4]	12.5 [16.8]	13.0 [17.4]	12.5 [16.8]	10.0 [13.4]	8.0 [10.7]	6.0 [8.1]	5.0 [6.7]	4.0 [5.4]
		int. <sup>1)</sup>	8.5 [11.4]	15.0 [20.1]	15.0 [20.1]	14.5 [19.4]	12.5 [16.8]	10.0 [13.4]	8.0 [10.7]	6.5 [8.7]	6.0 [8.1]
Max. pressure drop	bar [psi]	cont.	140 [2030]	175 [2540]	175 [2540]	175 [2540]	130 [1890]	110 [1600]	90 [1300]	70 [1020]	55 [800]
		int. <sup>1)</sup>	175 [2540]	200 [2900]	200 [2900]	200 [2900]	175 [2540]	140 [2030]	110 [1600]	100 [1450]	85 [1230]
		peak <sup>2)</sup>	225 [3260]	225 [3260]	225 [3260]	225 [3260]	225 [3260]	225 [3260]	200 [2900]	150 [2180]	130 [1880]
Max. oil flow	l/min [US gal/min]	cont.	40 [10.6]	60 [15.9]	60 [15.9]	60 [15.9]	60 [15.9]	60 [15.9]	60 [15.9]	60 [15.9]	
		int. <sup>1)</sup>	50 [13.2]	75 [19.8]	75 [19.8]	75 [19.8]	75 [19.8]	75 [19.8]	75 [19.8]	75 [19.8]	75 [19.8]
Max. starting pressure with unloaded shaft	bar [psi]	10 [145]	10 [145]	10 [145]	9 [130]	7 [100]	5 [75]	5 [75]	5 [75]	5 [75]	
Min. starting torque before burn-in	at max. press. drop cont.	80 [710]	150 [1330]	200 [1770]	250 [2210]	240 [2120]	260 [2300]	240 [2120]	260 [2300]	240 [2120]	
	at max. press. drop int. <sup>1)</sup>	100 [890]	170 [1510]	230 [2040]	280 [2480]	320 [2830]	330 [2920]	310 [2740]	350 [3100]	380 [3360]	

<sup>1)</sup> Intermittent operation: the permissible values may occur for max. 10% of every minute.

<sup>2)</sup> Peak load: the permissible values may occur for max. 1% of every minute.

Technical data for OMR with 1 in splined and 28.5 mm tapered shaft

Type		OMR	OMR	OMR	OMR	OMR	OMR	OMR	OMR		
Motor size		50	80	100	125	160	200	250	315	375	
Geometric displacement	cm <sup>3</sup>	51.6	80.3	99.8	125.7	199.6	199.8	249.3	315.7	372.6	
	in <sup>3</sup> /rev	[3.16]	[4.91]	[6.11]	[7.69]	[12.23]	[12.23]	[15.26]	[19.32]	[22.80]	
Max. speed	min <sup>-1</sup>	775	750	600	475	375	300	240	190	160	
	rpm	9.70	9.40	7.50	6.00	4.70	3.75	3.00	2.40	2.00	
Max. torque	N·m (lbf·in)	cont <sup>1)</sup>	100 [890]	195 [1730]	240 [2120]	300 [2660]	380 [3190]	380 [3190]	360 [3190]	360 [3190]	360 [3190]
		int <sup>2)</sup>	138 [1130]	220 [1930]	280 [2480]	340 [3010]	430 [3810]	440 [3890]	470 [4160]	470 [4160]	460 [4070]
		peak <sup>2)</sup>	170 [1510]	270 [2390]	325 [2830]	370 [3280]	460 [4070]	560 [4960]	600 [5310]	610 [5400]	600 [5310]
Max. output	kW hp	cont <sup>1)</sup>	7.0 [9.4]	12.5 [16.8]	13.0 [17.4]	12.5 [16.8]	12.5 [16.8]	10.0 [13.4]	7.0 [9.4]	5.0 [6.7]	5.0 [6.7]
		int <sup>2)</sup>	8.3 [11.4]	15.0 [20.1]	15.0 [20.1]	14.5 [19.4]	14.0 [18.8]	13.0 [17.4]	9.3 [12.7]	8.0 [10.7]	7.0 [9.4]
Max. pressure drop	bar psid	cont <sup>1)</sup>	140 [2030]	175 [2540]	175 [2540]	175 [2540]	165 [2390]	130 [1890]	100 [1450]	85 [1230]	70 [1020]
		int <sup>2)</sup>	175 [2540]	200 [2900]	200 [2900]	200 [2900]	200 [2900]	175 [2540]	140 [2030]	115 [1670]	90 [1310]
		peak <sup>2)</sup>	225 [3260]	225 [3260]	225 [3260]	225 [3260]	225 [3260]	225 [3260]	200 [2900]	150 [2190]	130 [1890]
Max. oil flow	l/min US gal/min	cont <sup>1)</sup>	40 [10.6]	60 [15.9]	60 [15.9]	60 [15.9]	60 [15.9]	60 [15.9]	60 [15.9]	60 [15.9]	60 [15.9]
		int <sup>2)</sup>	50 [13.2]	75 [19.8]	75 [19.8]	75 [19.8]	75 [19.8]	75 [19.8]	75 [19.8]	75 [19.8]	75 [19.8]
Max. starting pressure with unloaded shaft	bar psid	10 [145]	10 [145]	10 [145]	9 [130]	7 [100]	5 [75]	5 [75]	5 [75]	5 [75]	
Min. starting torque	at max. press. drop cont <sup>1)</sup>	90 [710]	150 [1330]	200 [1770]	250 [2210]	300 [2660]	300 [2660]	290 [2570]	315 [2790]	300 [2660]	
	at max. press. drop int <sup>2)</sup>	100 [890]	170 [1510]	230 [2040]	280 [2480]	350 [3100]	400 [3540]	400 [3540]	400 [3540]	400 [3540]	390 [3360]

<sup>1)</sup> Intermittent operation; the permissible values may occur for max. 10% of every minute.

<sup>2)</sup> Peak load; the permissible values may occur for max. 1% of every minute.

Technical data for OMR with 32 mm, 1 1/4 in cylindrical shaft and 35 mm, 1 1/4 in tapered shaft

Type		OMR 50	OMR 80	OMR 100	OMR 125	OMR 160	OMR 200	OMR 250	OMR 315	OMR 375	
Motor size		50	80	100	125	160	200	250	315	375	
Geometric displacement	cm <sup>3</sup>	51.6	80.3	99.8	125.7	159.6	199.8	249.3	315.7	372.6	
	[inch <sup>3</sup> ]	[3.16]	[4.91]	[6.11]	[7.69]	[9.77]	[12.23]	[15.26]	[19.32]	[22.80]	
Max. speed	min <sup>-1</sup>	cont <sup>1)</sup> 775	750	600	475	375	300	240	190	160	
	[rpm]	int <sup>1)</sup> 670	640	750	600	470	375	300	240	200	
Max. torque	N·m [lbf·in]	cont <sup>1)</sup>	100 [890]	195 [1730]	240 [2120]	300 [2660]	380 [3360]	450 [3980]	540 [4780]	550 [4870]	580 [5130]
		int <sup>1)</sup>	130 [1150]	220 [1957]	280 [2480]	340 [3010]	430 [3810]	500 [4430]	610 [5300]	690 [6110]	690 [6110]
		peak <sup>2)</sup>	170 [1510]	270 [2390]	320 [2830]	370 [3280]	460 [4070]	560 [4960]	710 [6280]	840 [7440]	830 [7350]
Max. output	kW [hp]	cont <sup>1)</sup>	7.0 [9.4]	12.5 [16.8]	13.0 [17.4]	12.5 [16.8]	12.5 [16.8]	11.0 [14.8]	10.0 [13.4]	9.0 [12.1]	7.5 [10.1]
		int <sup>1)</sup>	8.3 [11.4]	15.0 [20.1]	15.0 [20.1]	14.5 [19.4]	14.0 [18.8]	13.0 [17.4]	12.0 [16.1]	10.0 [13.4]	9.0 [12.1]
Max. pressure drop	bar [psi]	cont <sup>1)</sup>	140 [2030]	175 [2540]	175 [2540]	175 [2540]	175 [2540]	175 [2540]	175 [2540]	135 [1960]	115 [1670]
		int <sup>1)</sup>	175 [2540]	200 [2900]	200 [2900]	200 [2900]	200 [2900]	200 [2900]	200 [2900]	175 [2540]	150 [2160]
		peak <sup>2)</sup>	225 [3260]	225 [3260]	225 [3260]	225 [3260]	225 [3260]	225 [3260]	225 [3260]	225 [3260]	210 [3050]
Max. oil flow	l/min [US gal/min]	cont <sup>1)</sup>	40 [10.6]	60 [15.9]	60 [15.9]	60 [15.9]	60 [15.9]	60 [15.9]	60 [15.9]	60 [15.9]	60 [15.9]
		int <sup>1)</sup>	50 [13.2]	75 [19.8]	75 [19.8]	75 [19.8]	75 [19.8]	75 [19.8]	75 [19.8]	75 [19.8]	75 [19.8]
Max. starting pressure with unloaded shaft	bar [psi]	10 [145]	10 [145]	10 [145]	9 [130]	7 [100]	5 [75]	5 [75]	5 [75]	5 [75]	
Min. starting torque	at max. press. drop cont. N·m [lbf·in]	80 [710]	150 [1330]	200 [1770]	250 [2210]	320 [2830]	410 [3630]	500 [4430]	500 [4430]	470 [4170]	
	at max. press. drop int. <sup>1)</sup> N·m [lbf·in]	100 [890]	170 [1510]	230 [2040]	280 [2480]	370 [3280]	460 [4070]	550 [4870]	600 [5240]	570 [5050]	

Type			Max. inlet pressure	Max. return pressure with drain line
OMR 50 - 375	bar [psi]	cont <sup>1)</sup>	175 [2540]	175 [2540]
	bar [psi]	int. <sup>1)</sup>	200 [2900]	200 [2900]
	bar [psi]	peak <sup>2)</sup>	225 [3260]	225 [3260]

<sup>1)</sup> Intermittent operation: the permissible values may occur for max. 10% of every minute.

<sup>2)</sup> Peak load: the permissible value(s) may occur for max. 1% of every minute.

**Technical Data for  
 Parking Brake Motor  
 OMR F, OMR NF and  
 OMRW NF**

Technical data for brake motor		
Holding torque 1)	N·m [lb·in]	400 [3540]
Min. release pressure 2)	bar [psi]	21 [305]
Max. pressure in brake line	bar [psi]	200 [2900]

- 1) This brake is to be used only as a passive parking brake. It may not be used for dynamic braking.  
 2) Brake motors must always have a drain line. The brake release pressure is the difference between the pressure in the brake release line and the pressure in the drain line.

**Function:**

In normal condition where there is no pressure on the integrated brake in OMR, i.e. the brake is applied. The brake is released when hydraulic pressure of 21 bar [300psi] min. is applied to the brake release port (1).

The pressure forces the piston (2) against the springs (3 and 4) disengaging the outer and inner discs (5 and 6) from each other so that the cardan shaft (7) and consequently output shaft (8) become free to rotate.

If the pressure on the brake release port is reduced to less than 21 bar [300psi], the springs force the piston and pressure pad (9) against the brake discs and the cardan shaft/output shaft begin to lock up.

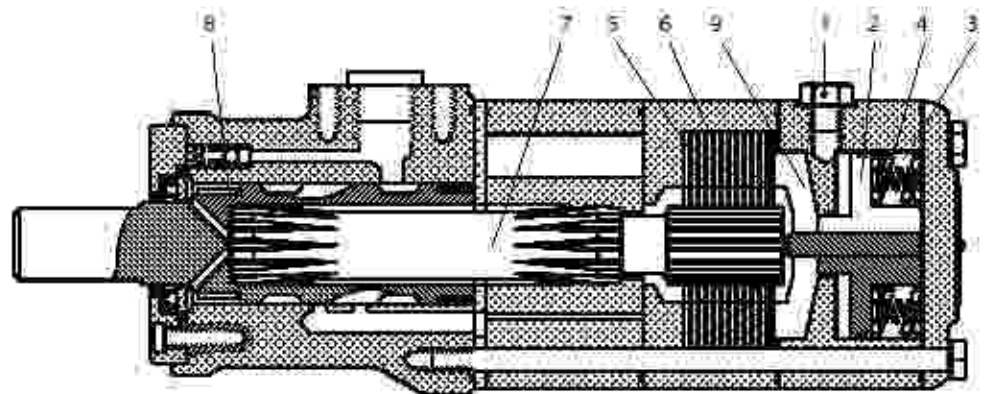

151-1728 1A 10

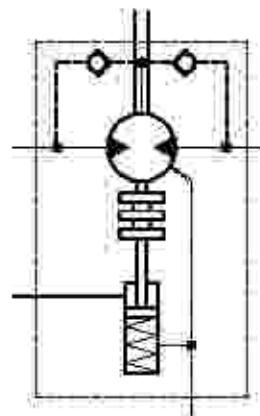

151-1728 1A

**OMR with High Pressure Shaft Seal (HPS)**

OMR with HPS, without check valves and without drain connection:  
 The shaft seal pressure equals the average of input pressure and return pressure

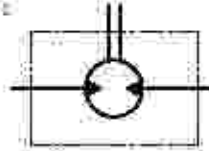

111-1743.10

$$P_{\text{seal}} = \frac{P_{\text{in}} + P_{\text{return}}}{2}$$

Max. permissible shaft seal pressure

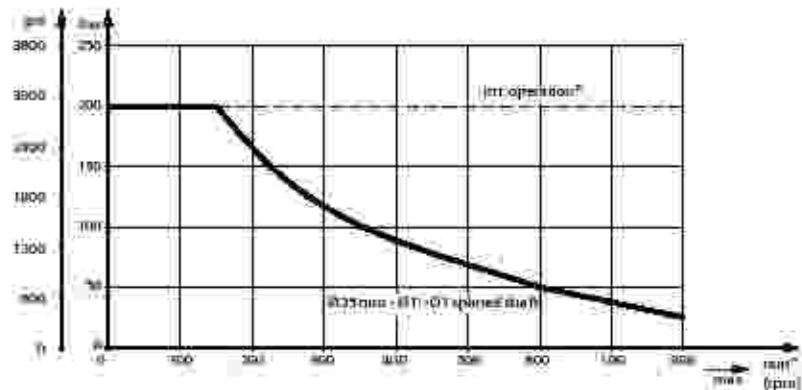

111-1836.10

**OMR with Standard Shaft Seal**

OMR with standard shaft seal, check valves and without use of drain connection:  
 The pressure on the shaft seal never exceeds the pressure in the return line

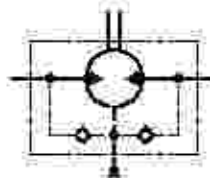

111-120.10

OMR with standard shaft seal, check valves and with drain connection:  
 The shaft seal pressure equals the pressure on the drain line.

Max. return pressure without drain line or max. pressure in the drain line

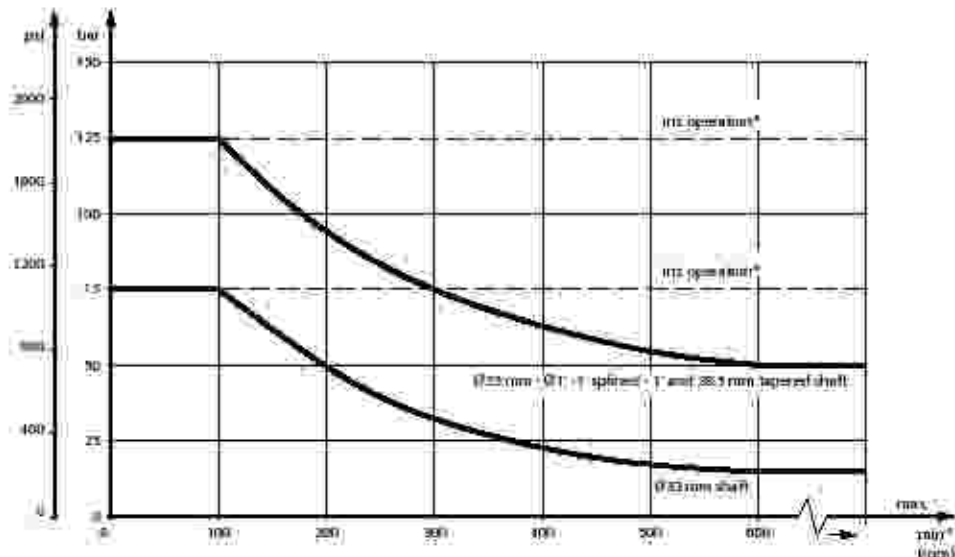

111-1363.10

\* Intermittent operation; the permissible values may occur for max. 10% of every minute.

**Pressure Drop in Motor**

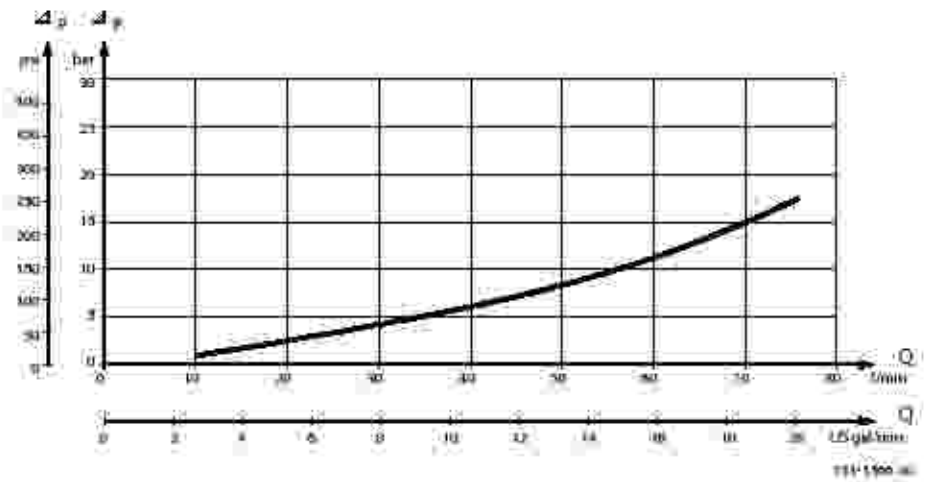

The curve applies to an unloaded motor shaft and an oil viscosity of 35 mm<sup>2</sup>/s [165 SUS]

**Oil Flow in Drain Line**

The table shows the max. oil flow in the drain line at a return pressure less than 5–10 bar [75–150 psi]

Pressure drop bar [psi]	Viscosity mm <sup>2</sup> /s [SUS]	Oil flow in drain line l/min [US gal/min]
100 [1450]	20 [100]	2.5 [0.66]
	35 [165]	1.8 [0.78]
140 [2030]	20 [100]	3.5 [0.93]
	35 [165]	2.8 [0.74]

**Direction of Shaft  
 Rotation**

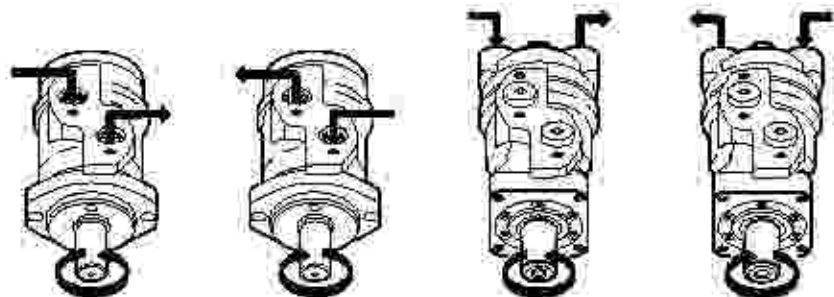

**Permissible Shaft Loads  
 for OMR**

The permissible radial shaft load ( $P_R$ ) depends on

- Speed ( $n$ )
- Distance ( $l$ ) from the point of load to the mounting flange
- Mounting flange version
- Shaft version

Mounting flange	4-oval flange** 2-hole oval flange (European version)	4-hole oval flange	Square flange** 2-hole oval flange (US-version)
Shaft version	25 mm cylindrical shaft 1 in cylindrical shaft 1 in splined shaft	32 mm cylindrical shaft	25 mm cylindrical shaft
Permissible shaft load ( $P_R$ ) - l in mm	$\frac{800}{n} \cdot \frac{250000}{95 + l}$ N*	$\frac{800}{n} \cdot \frac{187500}{95 + l}$ N*	$\frac{800}{n} \cdot \frac{250000}{101 + l}$ N*
Permissible shaft load ( $P_R$ ) - l in inch	$\frac{800}{n} \cdot \frac{2215}{3.74 + l}$ lbf*	$\frac{800}{n} \cdot \frac{1660}{3.74 + l}$ lbf*	$\frac{800}{n} \cdot \frac{2215}{3.98 + l}$ lbf*

\*  $n \geq 200 \text{ min}^{-1}$  (rpm);  $l \leq 55 \text{ mm}$  (2.2 in)  
 $n < 200 \text{ min}^{-1}$  (rpm);  $l > 55 \text{ mm}$   $\Rightarrow P_{R, \text{max}} = 8000 \text{ N}$  (1800 lbf)  
 \*\* For both European and US-version

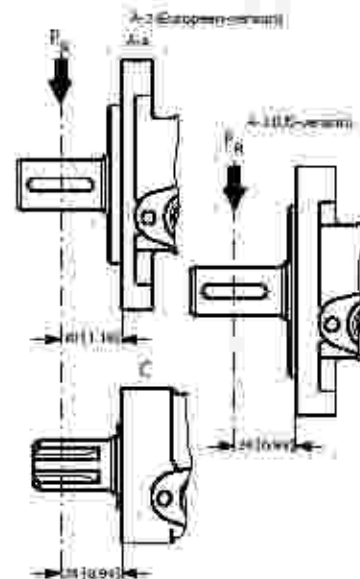
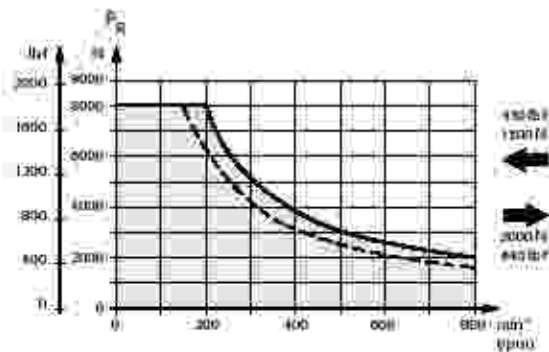

— cylindrical shaft 32 mm (1.26 in)  
 - - - other shaft versions

The curve shows the relation between  $P_R$  and  $n$

- when  $l = 30 \text{ mm}$  (1.18 in) for motors with A2 (European version) and A4 oval mounting flange
- when  $l = 24 \text{ mm}$  (0.94 in) for motors with square mounting flange and A2 (US version)

For applications with special performance requirements we recommend OMR with the output shaft running in needle bearings.



**Permissible Shaft Load  
 for OMR N and OMR NF  
 with Needle Bearings**

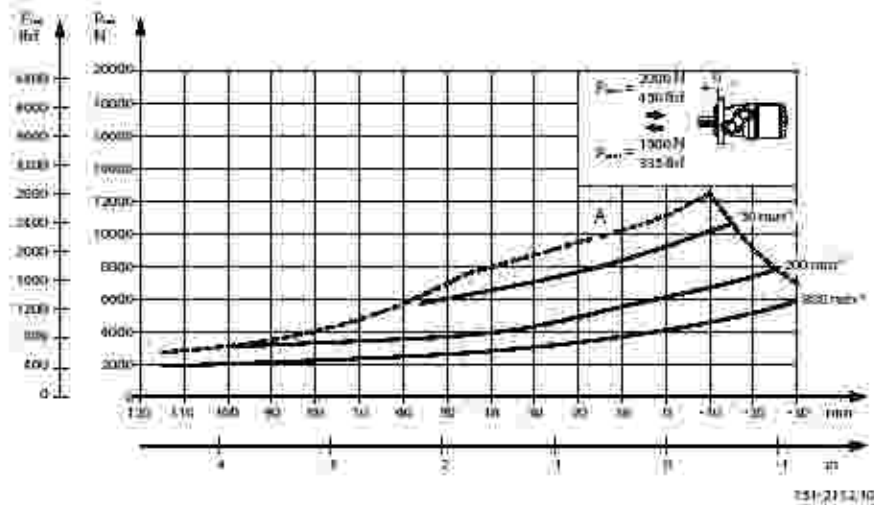

The output shaft on OMR N and OMR NF runs in needle bearings. These bearings and the recessed mounting flange allow a higher permissible radial load in comparison to OMR motors with slide bearings.

The permissible radial load on the shaft is shown for different speeds as a function of the distance from the mounting flange to the point of load application.

Curve A shows max. radial shaft load. Any shaft load exceeding the values quoted in the curve will involve a risk of breakage.

The other curves apply to a B10 bearing life of 2000 hours at the number of revolutions indicated by the curve letter. Mineral based hydraulic oil with a sufficient content of anti-wear additives must be used.

Bearing life calculations can be made using the explanation and formula provided in the chapter »Bearing dimensioning« in the technical information »General« DHMH.PX.100, G2.02 520L0232.

Permissible Shaft Load  
 for OMRW N and OMRW  
 NF with Needle Bearings

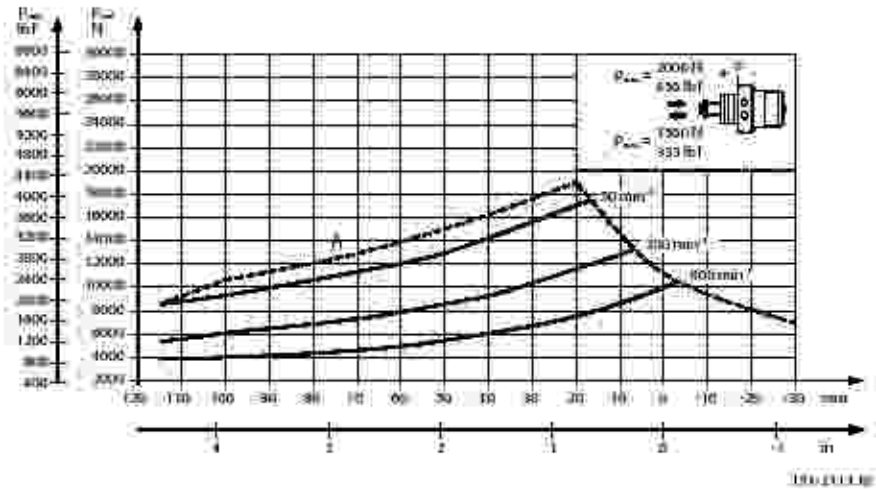

The output shaft on OMRW N runs in needle bearings. These bearings and the recessed mounting flange allow a higher permissible radial load in comparison to OMR motors with slide bearings.

The permissible radial load on the shaft is shown for different speeds as a function of the distance from the mounting flange to the point of load application.

Curve A shows max. radial shaft load. Any shaft load exceeding the values quoted in the curve will involve a risk of breakage.

The other curves apply to a B10 bearing life of 2000 hours at the number of revolutions indicated by the curve letter. Mineral based hydraulic oil with a sufficient content of anti-wear additives must be used.

Bearing life calculations can be made using the explanation and formula provided in the chapter »Bearing dimensioning« in the technical information »General« DHMH.PK.100. G2.02. 520L0232.

Function Diagrams

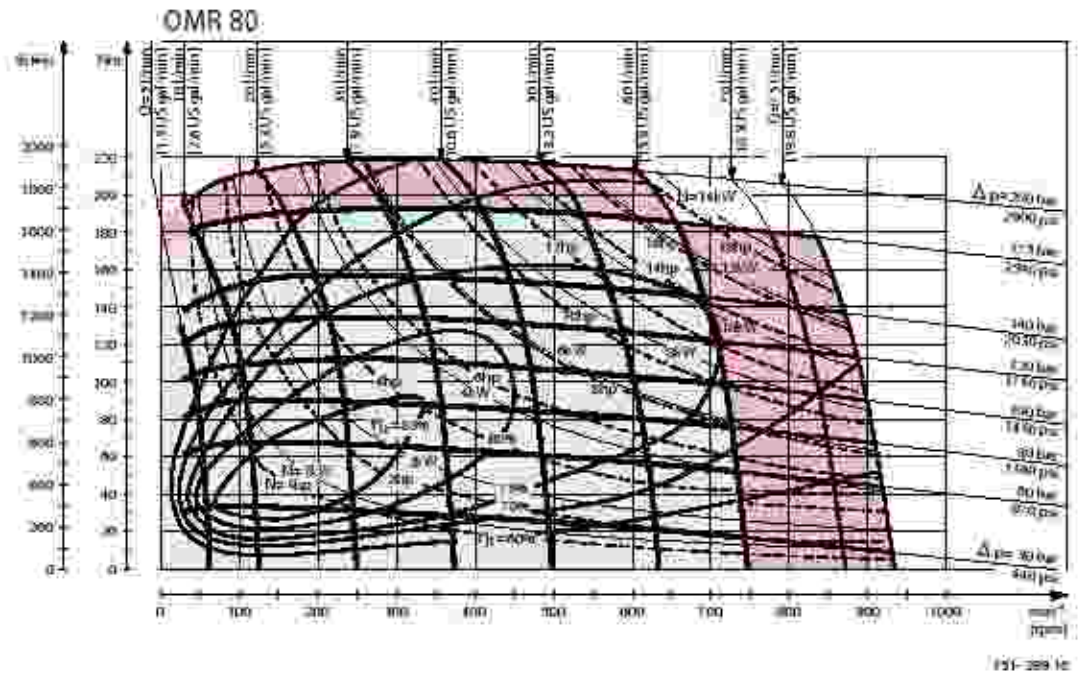
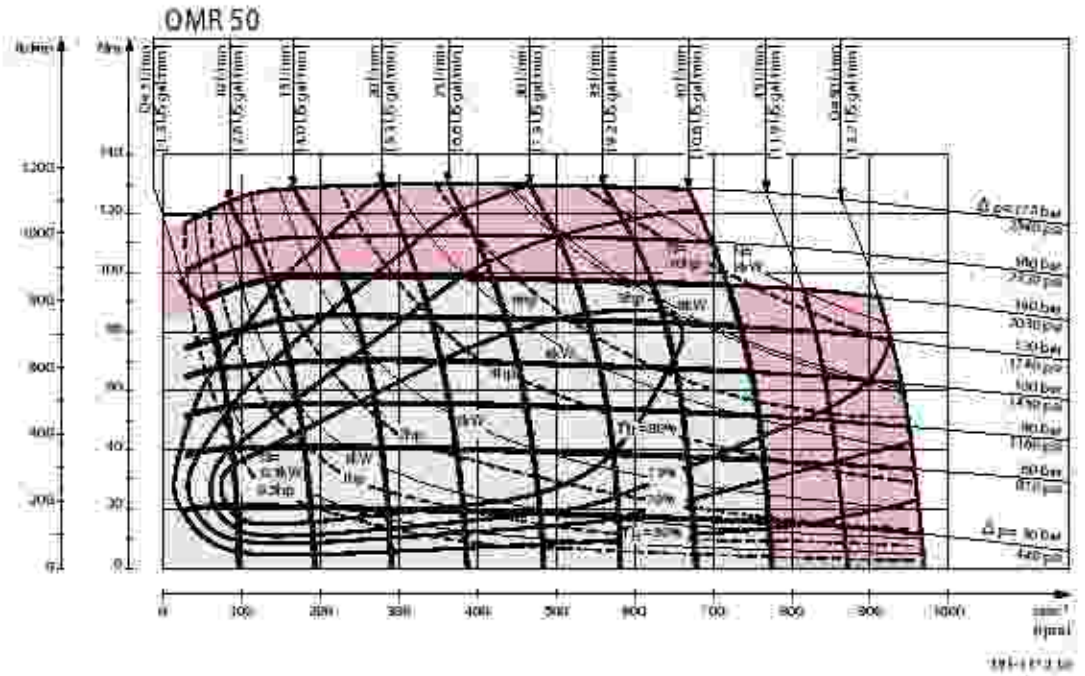

Explanation of function diagram use, basis and conditions can be found on page 7.

Continuous range

Intermittent range (max. 10% operation every minute)

Max. permissible continuous/intermittent pressure drop for the actual shaft version can be found on page 42 - 44.

Intermittent pressure drop and oil flow must not occur simultaneously.

Function Diagrams

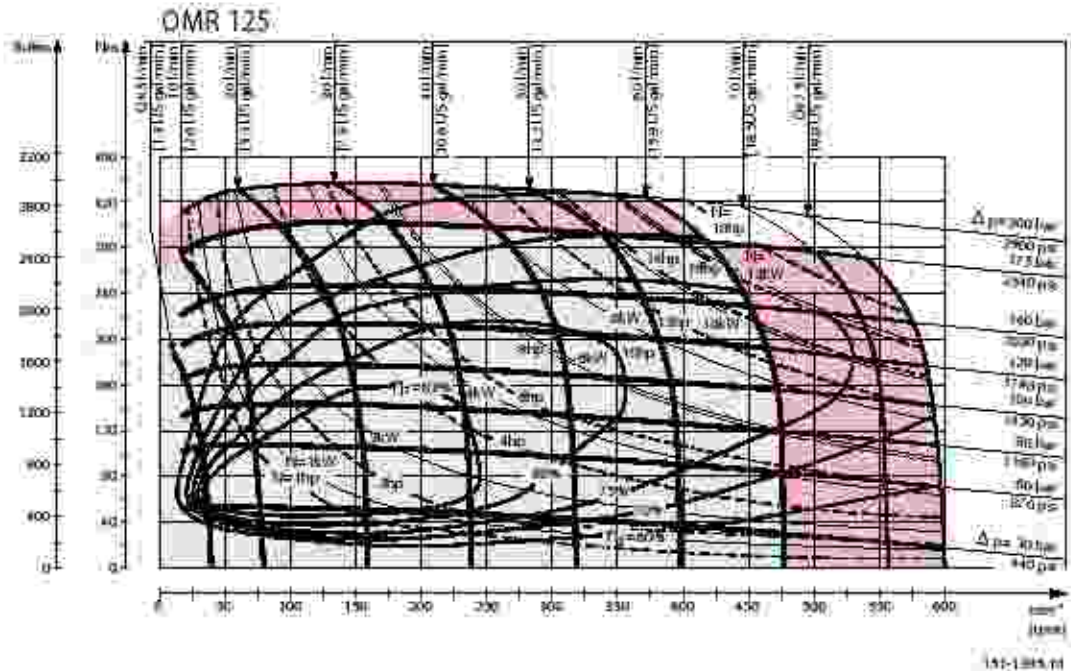
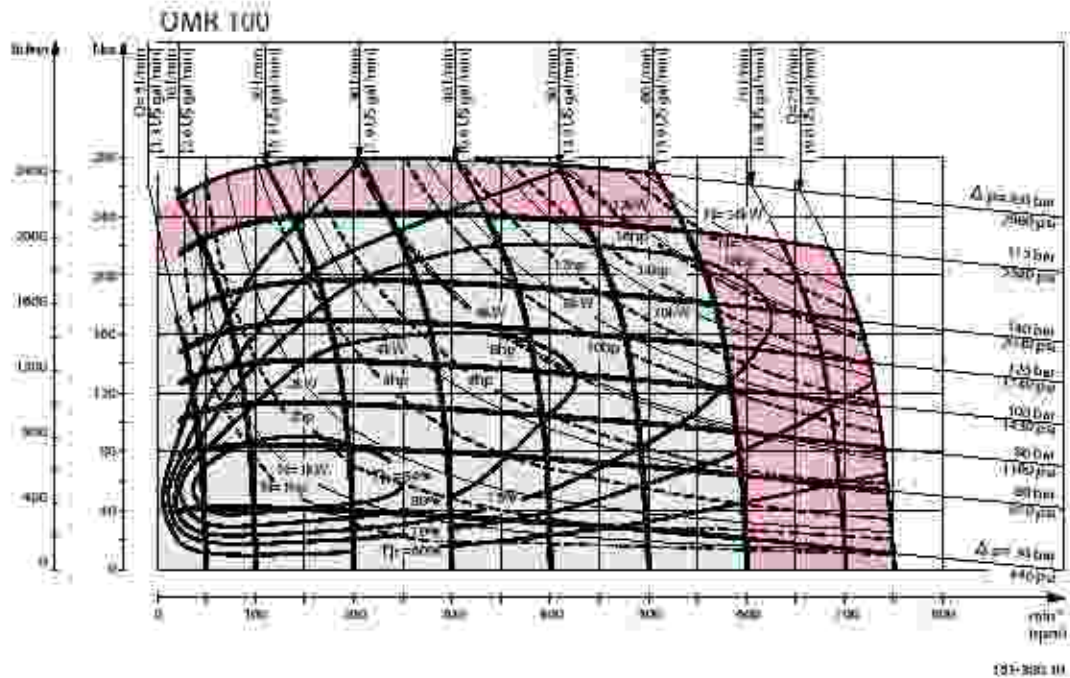

Explanation of function diagram use, basis and conditions can be found on page 7.

Continuous range

Intermittent range (max. 10% operation every minute)

Max. permissible continuous/intermittent pressure drop for the actual shaft version can be found on page 42-44.

Intermittent pressure drop and oil flow must not occur simultaneously

Function Diagrams

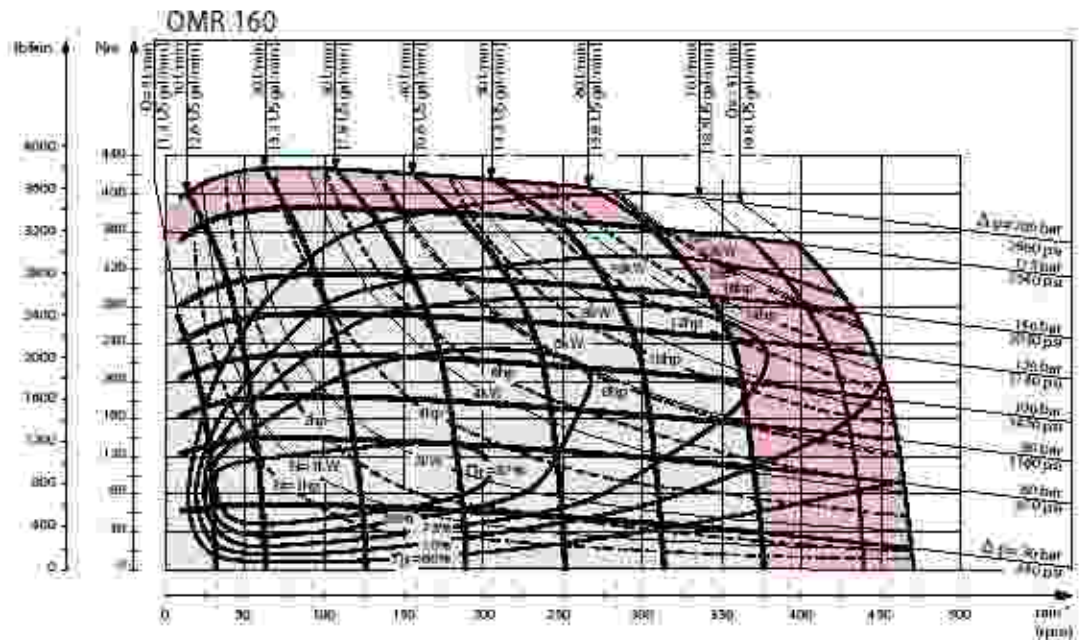

151-106.00

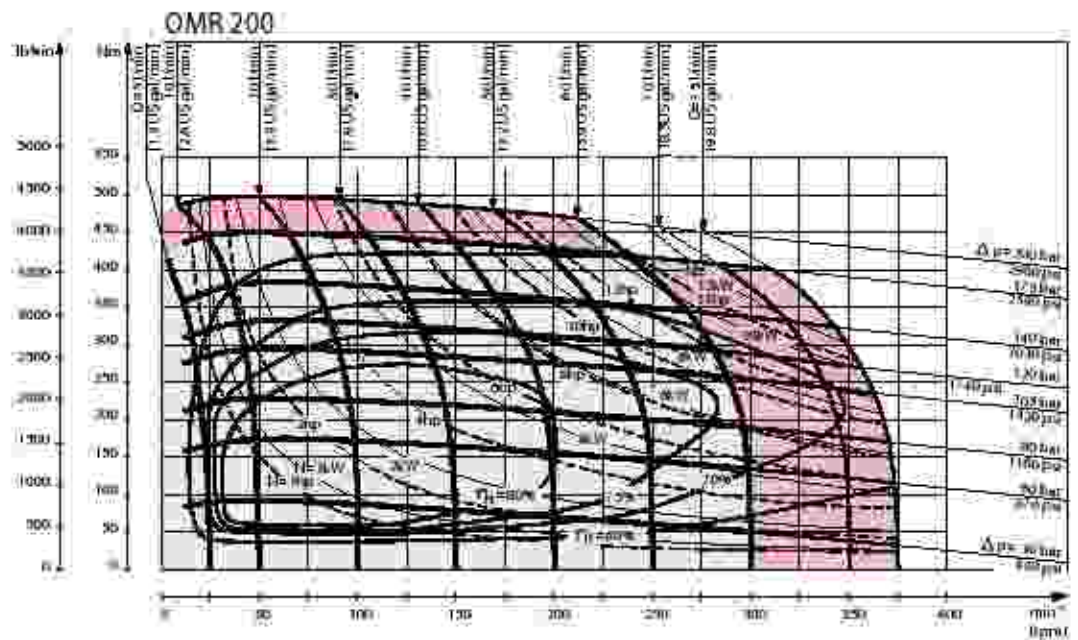

151-1386.00

Explanation of function diagram use, basis and conditions can be found on page 7.

Continuous range

Intermittent range (max. 10% operation every minute)

Max. permissible continuous/intermittent pressure drop for the actual shaft version can be found on page 42 - 44.

Intermittent pressure drop and oil flow must not occur simultaneously.

Function Diagrams

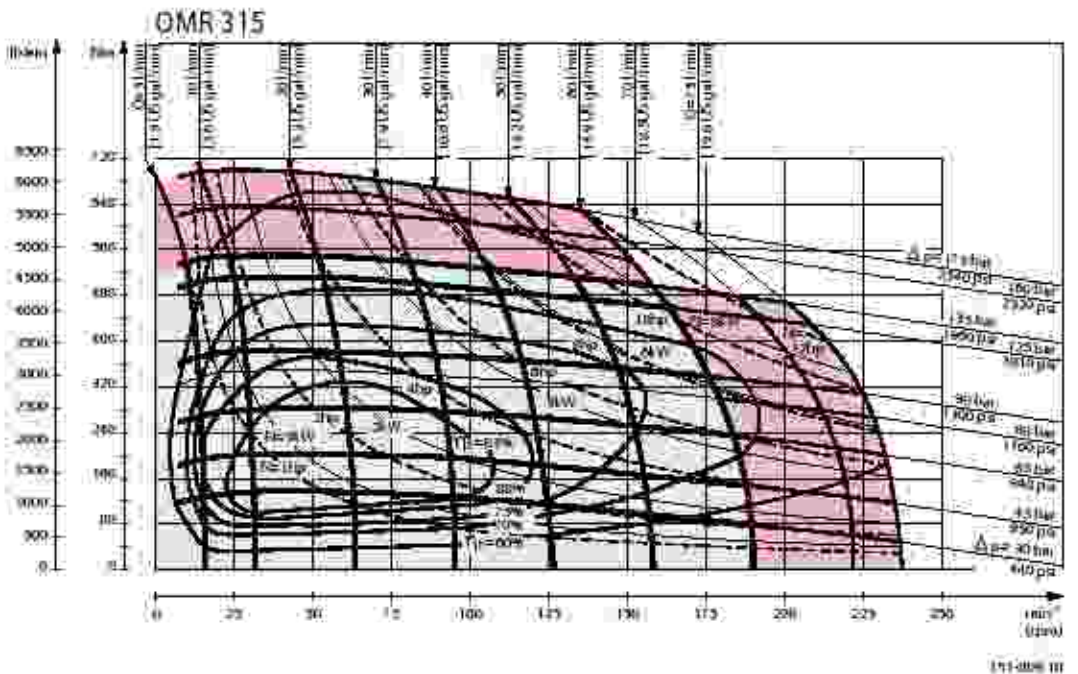
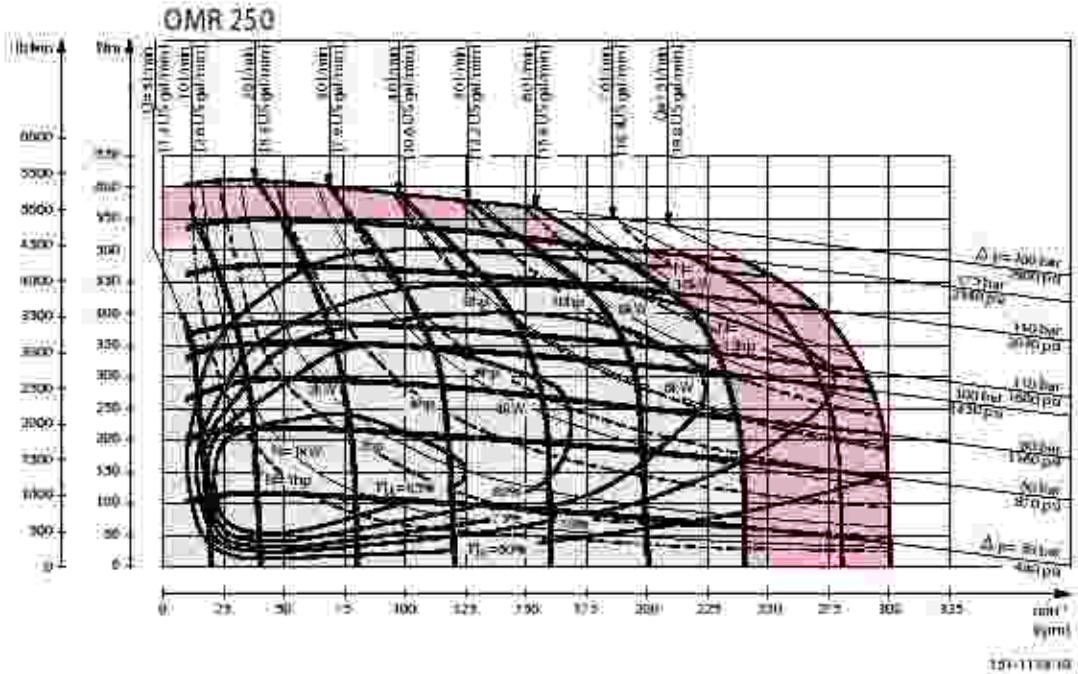

Explanation of function diagram use, basis and conditions can be found on page 7.

Continuous range

Intermittent range (max. 10% operation every minute)

Max. permissible continuous/intermittent pressure drop for the actual shaft version can be found on page 42-44.

Intermittent pressure drop and oil flow must not occur simultaneously

Function Diagrams

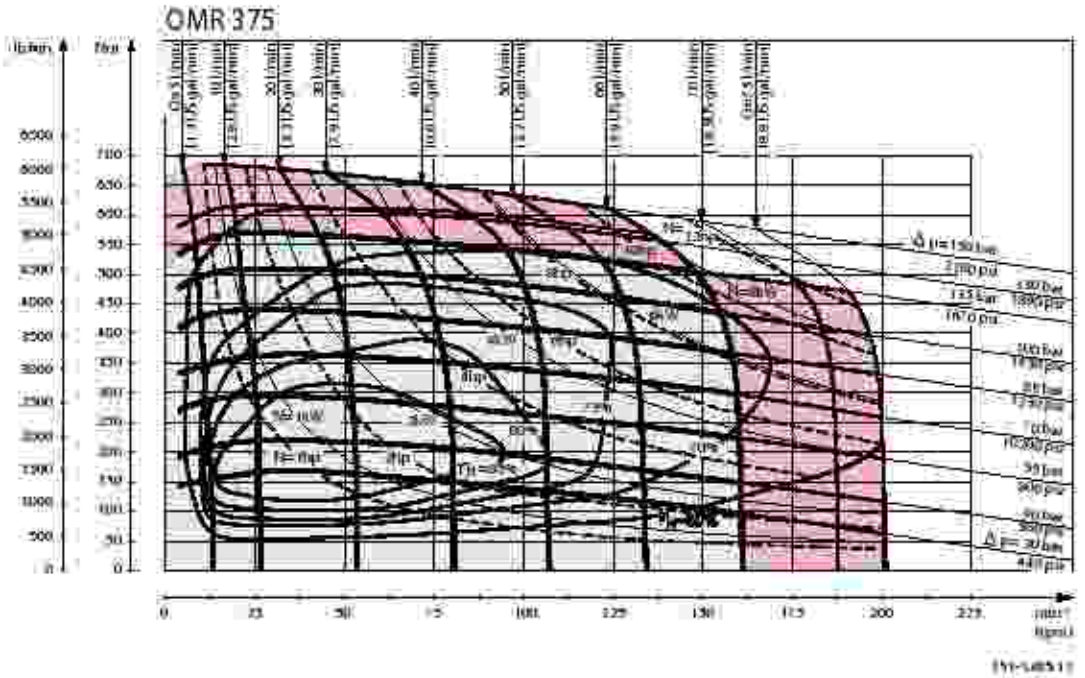

Explanation of function diagram use, basis and conditions can be found on page 7.

- Continuous range
  - Intermittent range (max. 10% operation every minute)
- Max. permissible continuous/intermittent pressure drop for the actual shaft version can be found on page 42-44.

---

Intermittent pressure drop and oil flow must not occur simultaneously.

---

**Shaft Version**

- A: Cylindrical shaft  
25 mm  
D: Parallel key  
A8 • 7 - 32  
DIN 6885

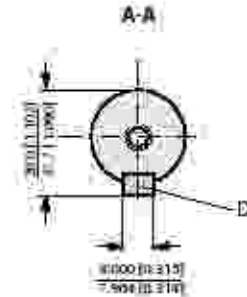
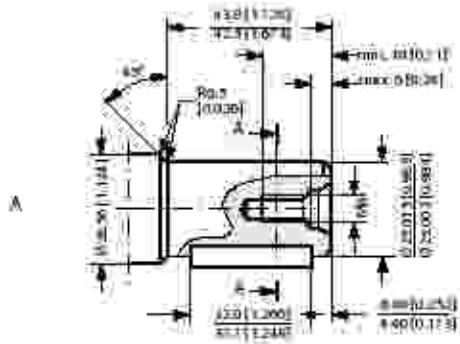

- B: Cylindrical shaft (1) m  
E: Parallel key  
B • 19 • 1.14 m  
B.S: 46

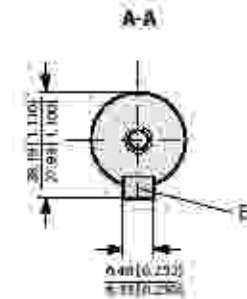
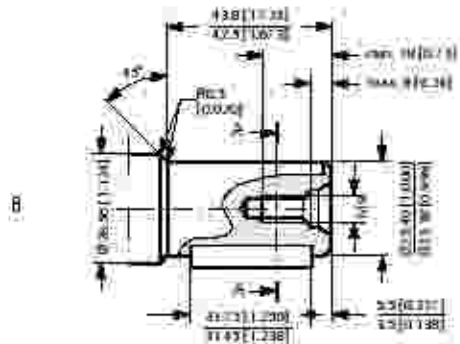

**US version**

- C: Cylindrical shaft  
1 in  
F: Parallel key  
W • 3/8 • 1 3/4 in  
B.S: 46

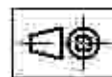
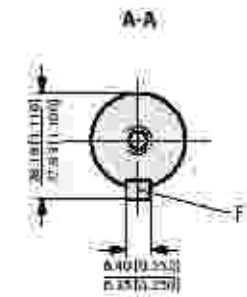
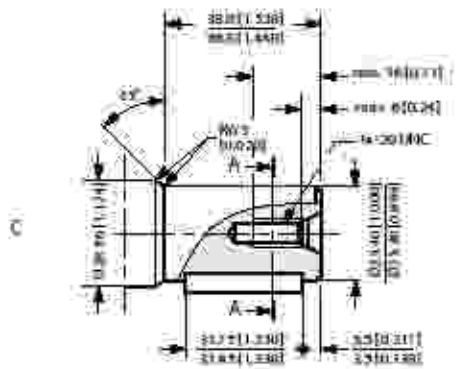



Shaft Version

- D: Cylindrical shaft  
22 mm
- G: Parallel key  
A 10 × 8 × 45  
DIN 6855

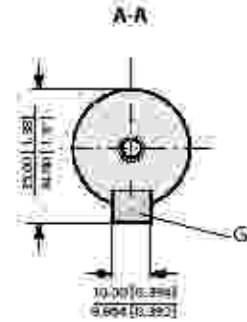
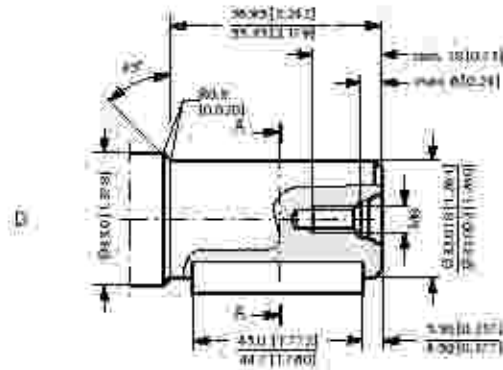

- US version
- E: Cylindrical shaft  
1 1/4 in
- H: Parallel key  
3/8 × 3/8 × 1 1/4 in  
B.S. 46

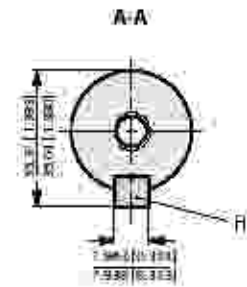
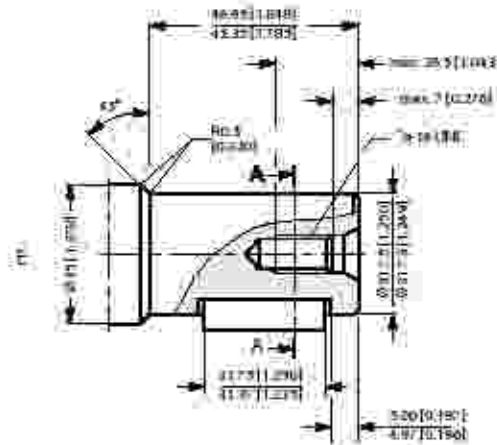

- F: Involute splined shaft  
B.S. 2059 (SAE 6 B)

Straight-sided,  
bottom fitting, deep  
Fit 2  
Nom. size 1 in.

\*Deviates from  
B.S. 2059 (SAE 6 B)

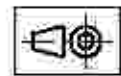
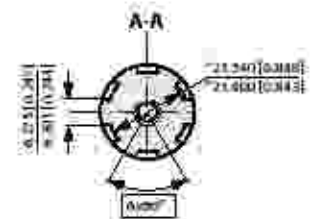
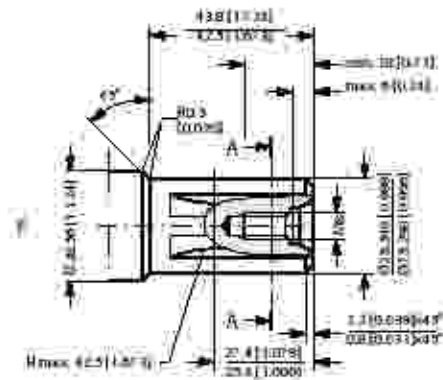

TREK1001-02

Shaft Version

US version

- G Splined shaft
- SAE 6 B I.B.S. 20591
- Straight-sided
- bottom fitting, deep
- Fit 2
- Nom. size 1 in.
- \* Deviate from
- SAE 6 B I.B.S. 20591

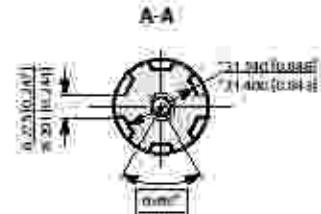
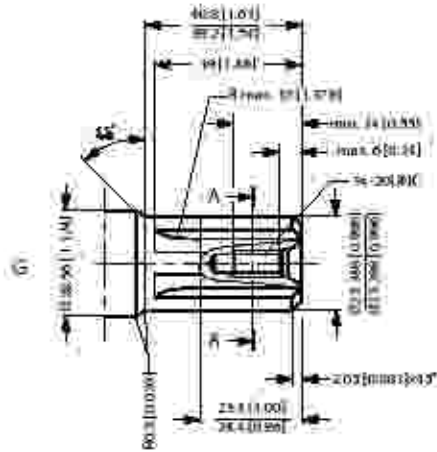

- H: Tapered shaft 28.5 mm (ISO/R775)
- K: DIN 937 NY 30
- Tightening torque: 100 ± 10 N·m [88.5 ± 8.5 lbf·ft]
- J: Taper 1:10
- L: Parallel key B5 · 5 - 14 DIN 6885

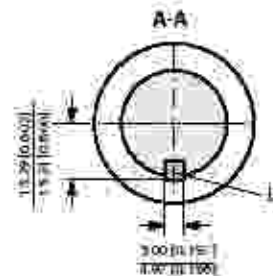
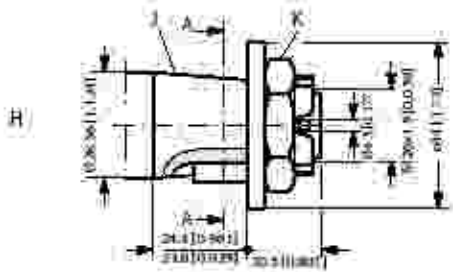

- I: Tapered shaft 35 mm
- N: DIN 937 NY 41
- Tightening torque: 200 ± 10 N·m [177.0 ± 8.5 lbf·ft]
- M: Taper 1:10
- P: Parallel key B6 · 6 - 20 DIN 6885

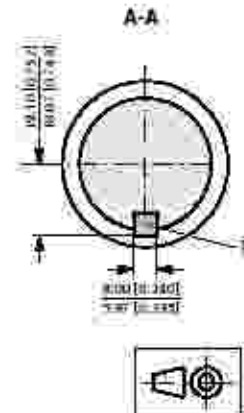
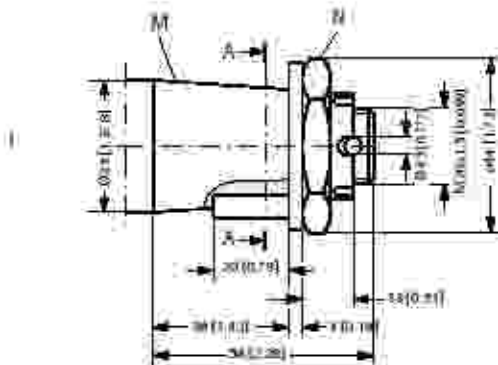

15/1000 11

**Shaft Version**

- J: Tapered shaft 1:6 in.
- K: Cone 1:8  
SAE J50.1
- E: 1-20 UNEF  
Across flats 1 1/8  
Tightening torque:  
200 ± 10 Nm [1770 ± 83 (bf·ft)]
- M: Parallel key  
3/16 - 7/16 - 1 1/4  
SAE J50.1

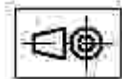
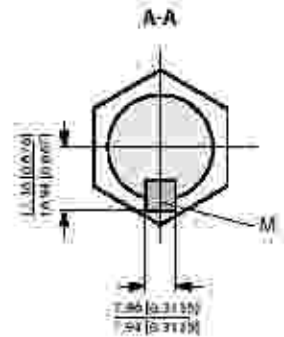
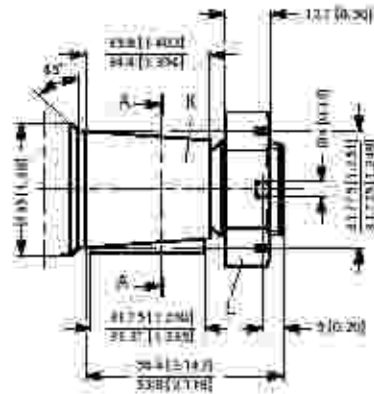

151-1548.11

Port Thread Versions

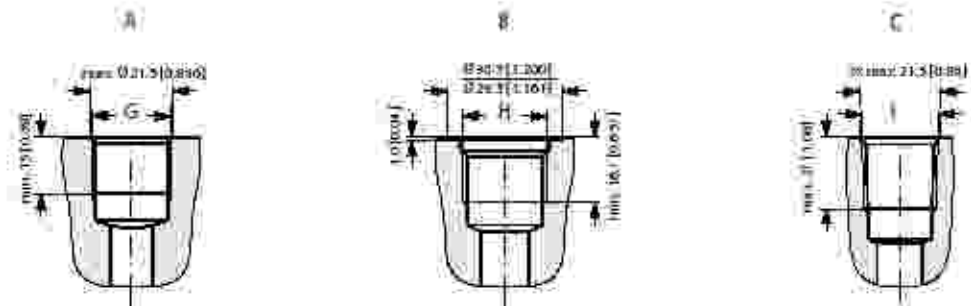

A: G main ports  
 G: ISO 228/T - G½  
 O-ring boss port

B: UNF main ports  
 H: 7/8 - 14 UNF  
 I: 5/8 - 18 UNF  
 O-ring boss port

C: NPTF main ports  
 I: 5/8 - 18 NPTF  
 O-ring boss port



D: G drain port  
 E: ISO 228/F - G¼  
 O-ring boss port

E: UNF drain port  
 J: 7/8 - 20 UNF  
 K: 7/8 - 20 UNF  
 O-ring boss port

15-2044-11

Manifold Mount

European version

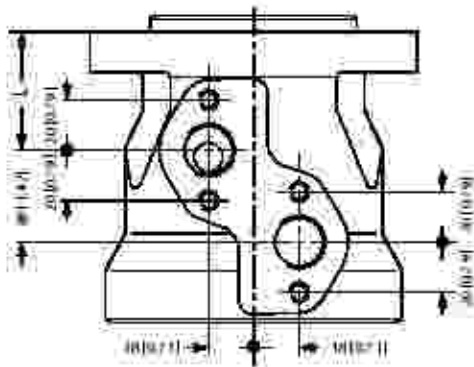

L: see dimensional drawing for given GMR motor on pages 64 - 74

**Dimension:**

Side port version with 2-hole oval mounting flange (A2 flange)  
 With high pressure shaft seal

Type	Max. L, mm [in]	L, mm [in]
OMR 50	136.3 [5.37]	9.0 [0.35]
OMR 80	141.5 [5.57]	14.0 [0.55]
OMR 100	145.0 [5.71]	17.4 [0.69]
OMR 125	149.5 [5.89]	21.6 [0.86]
OMR 160	155.3 [6.12]	27.8 [1.09]
OMR 200	162.5 [6.40]	34.8 [1.37]
OMR 250	171.5 [6.75]	43.5 [1.71]
OMR 315	182.5 [7.19]	54.6 [2.16]
OMR 375	192.7 [7.59]	65.0 [2.56]

- D: G 3/4: 15 mm [0.59 in] deep
- E: M8: 13 mm [0.51 in] deep (4 pcs)

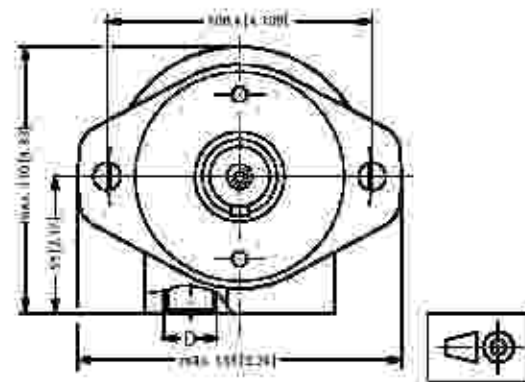
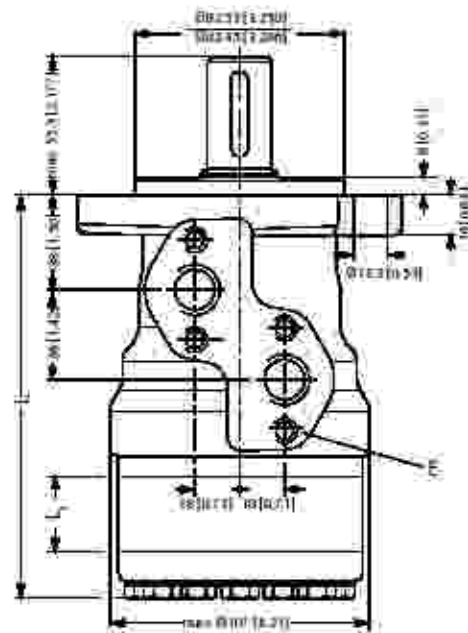

131-07-0611

**Dimensions**

Side port version with 2-hole oval mounting flange (A2 flange).  
 With check valves and drain connection.  
 With high pressure shaft seal.

Type	Max. L mm [in]	L mm [in]
OMR 50	130.5 [5.37]	9.0 [0.35]
OMR 80	141.5 [5.57]	14.0 [0.55]
OMR 100	145.0 [5.71]	17.4 [0.69]
OMR 125	149.5 [5.89]	21.6 [0.86]
OMR 160	155.5 [6.12]	27.8 [1.09]
OMR 200	162.5 [6.40]	34.8 [1.37]
OMR 250	171.5 [6.75]	43.5 [1.71]
OMR 315	182.5 [7.19]	54.8 [2.16]
OMR 375	192.7 [7.59]	65.0 [2.56]

- C: Drain connection  
 G<sub>1/4</sub>: 15 mm [0.47 in] deep
- D: G<sub>1/2</sub>: 15 mm [0.59 in] deep
- E: M8: 13 mm [0.51 in] deep  
 (4 pcs.)

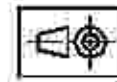
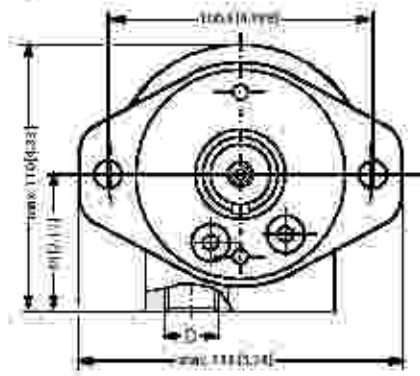
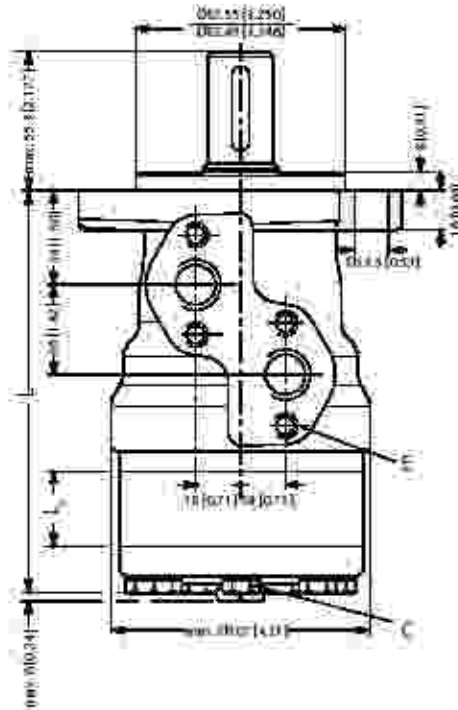

(1) - M8 (1)

**Dimensions**

OMR, OMR C and OMR N  
 Side port version with Z-noise oval mounting flange (AZ flange)

Output shaft max.	mm L <sub>1</sub> [in]
Cylindrical shaft 32 mm [1.26 in]	68.3 [2.69]
Cylindrical shaft 25 mm [0.98 in]	55.3 [2.18]
Tapered shaft 28.96 mm [1.12 in]	56.3 [2.19]

Type	Max. L mm [in]	L mm [in]
OMR 50	130.5 [5.14]	9.0 [0.35]
OMR 80	141.5 [5.57]	14.0 [0.55]
OMR 100	145.0 [5.71]	17.4 [0.69]
OMR 125	140.5 [5.53]	21.8 [0.86]
OMR 160	153.5 [6.04]	27.8 [1.09]
OMR 200	162.5 [6.40]	34.8 [1.37]
OMR 250	171.5 [6.75]	43.5 [1.71]
OMR 315	182.5 [7.19]	54.6 [2.15]
OMR 375	192.7 [7.59]	65.0 [2.56]

- C: Drain connection  
G 3/4: 12 mm [0.47 in] deep
- D: G 1/2: 15 mm [0.59 in] deep
- E: M8: 13 mm [0.51 in] deep  
(4 pcs.)

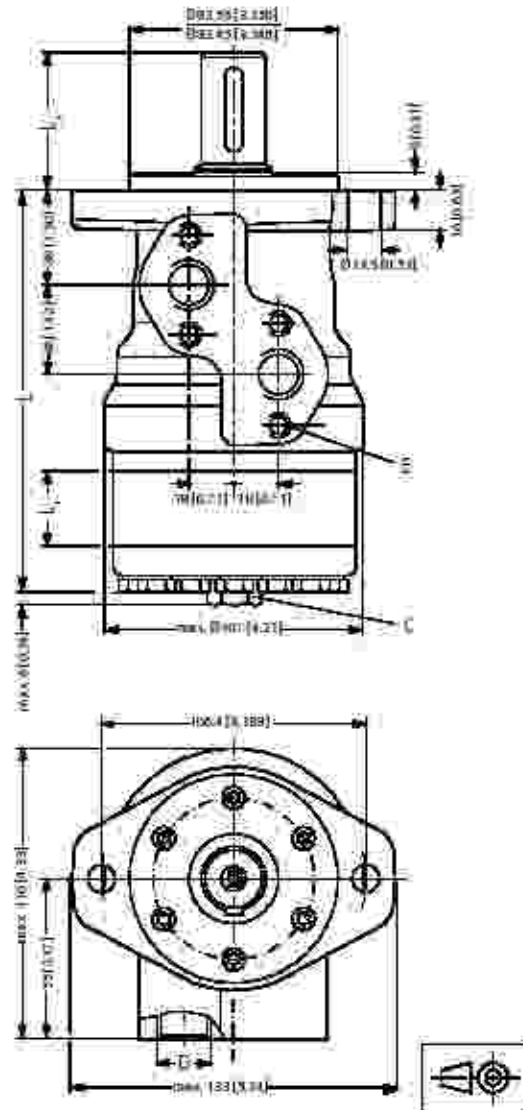

100-1049-18

**Dimensions**

*End port version with 2-hole oval mounting flange (A2-flange)*

Type	Max. L mm [in]	L mm [in]
OMR 50	131.6 [5.96]	9.0 [0.35]
OMR 80	150.6 [6.72]	14.0 [0.55]
OMR 100	160.0 [6.30]	17.4 [0.69]
OMR 125	164.4 [6.47]	21.8 [0.86]
OMR 160	170.4 [6.71]	27.8 [1.09]
OMR 200	177.4 [6.98]	34.8 [1.37]
OMR 250	186.1 [7.33]	43.3 [1.71]
OMR 315	197.4 [7.77]	54.8 [2.16]
OMR 375	207.6 [8.17]	63.0 [2.56]

C: G 1/2 12 mm [0.47 in] deep  
 D: G 1/2 15 mm [0.59 in] deep

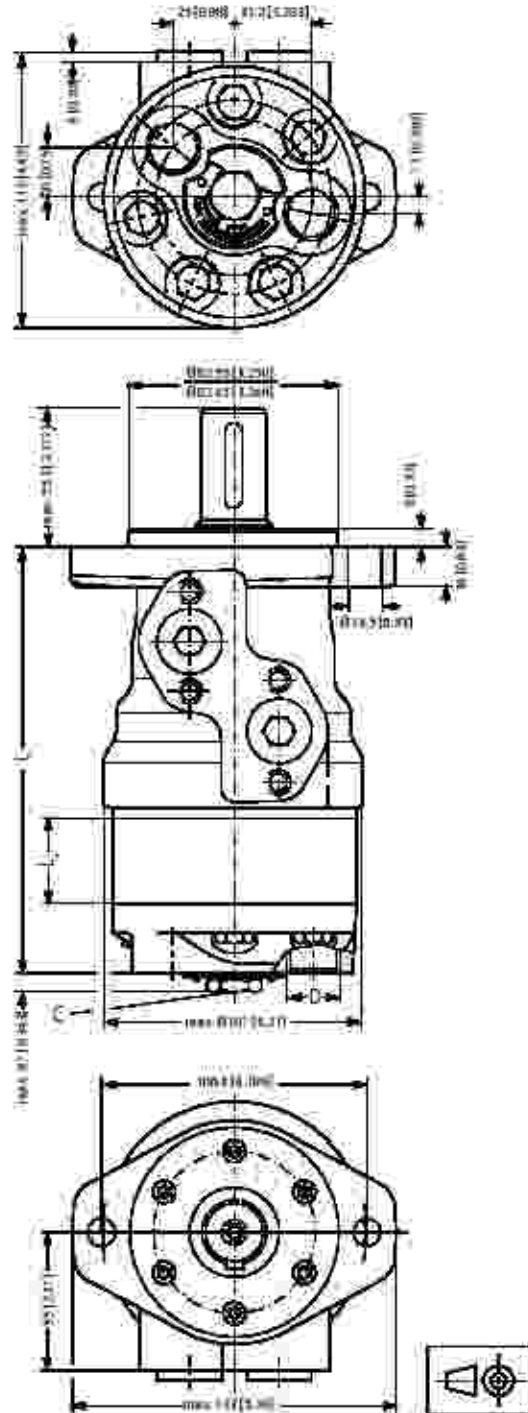

03-10527



**Dimension:**

*Safe port version with 2-noise oval mounting flange (A2-flange)*

Type	Max. L, mm [in]	L, mm [in]
OMR 50	142.5 [5.61]	9.0 [0.35]
OMR 80	147.5 [5.81]	14.0 [0.55]
OMR 100	151.0 [5.93]	17.4 [0.69]
OMR 125	155.4 [6.12]	21.6 [0.86]
OMR 160	161.5 [6.36]	27.8 [1.09]
OMR 200	168.5 [6.63]	34.8 [1.37]
OMR 250	177.5 [6.99]	43.5 [1.71]
OMR 315	188.5 [7.42]	54.6 [2.16]
OMR 375	198.5 [7.82]	64.8 [2.56]

- C: Drain connection  
 1/2"-20 mm UNF-  
 12 mm [0.47 in] deep
- D: 1/8"-14 UNF  
 16.76 mm [0.66 in] deep
- E: M6: 13 mm [0.51 in] deep  
 (4-off.)

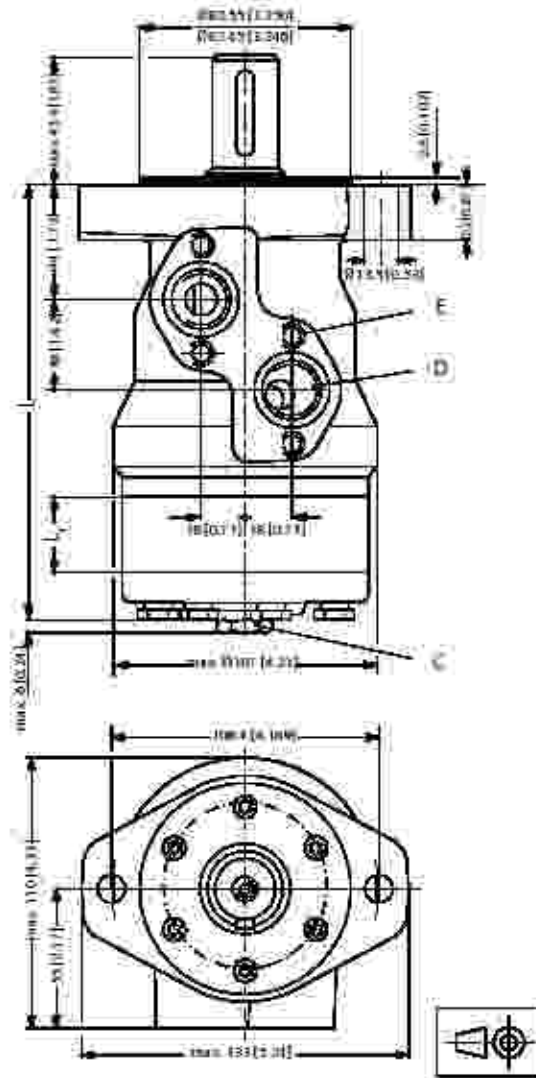

18F-A22612

**Dimensions**

Side port version with 4-hole oval mounting flange (A4 flange)

Output shaft max.	mm L [in]
Cylindrical shaft 32 mm [1.26 in]	58.3 [2.29]
Cylindrical shaft 25 mm [0.98 in]	35.3 [1.38]
Tapered shaft 28.56 mm [1.12 in]	58.3 [2.29]

Type	Max. L mm [in]	L mm [in]
OMR 50	136.5 [5.37]	9.0 [0.35]
OMR 80	141.5 [5.57]	14.0 [0.55]
OMR 100	145.0 [5.71]	17.4 [0.69]
OMR 125	149.5 [5.89]	21.8 [0.86]
OMR 160	155.5 [6.12]	27.8 [1.09]
OMR 200	162.5 [6.40]	34.8 [1.37]
OMR 250	171.5 [6.75]	43.5 [1.71]
OMR 315	182.5 [7.19]	54.8 [2.16]
OMR 375	192.7 [7.59]	65.0 [2.56]

- C: Drain connection  
G 1/4; 15 mm [0.47 in] deep
- D: G 1/4; 15 mm [0.59 in] deep
- E: M6; 13 mm [0.51 in] deep  
4 pcs.

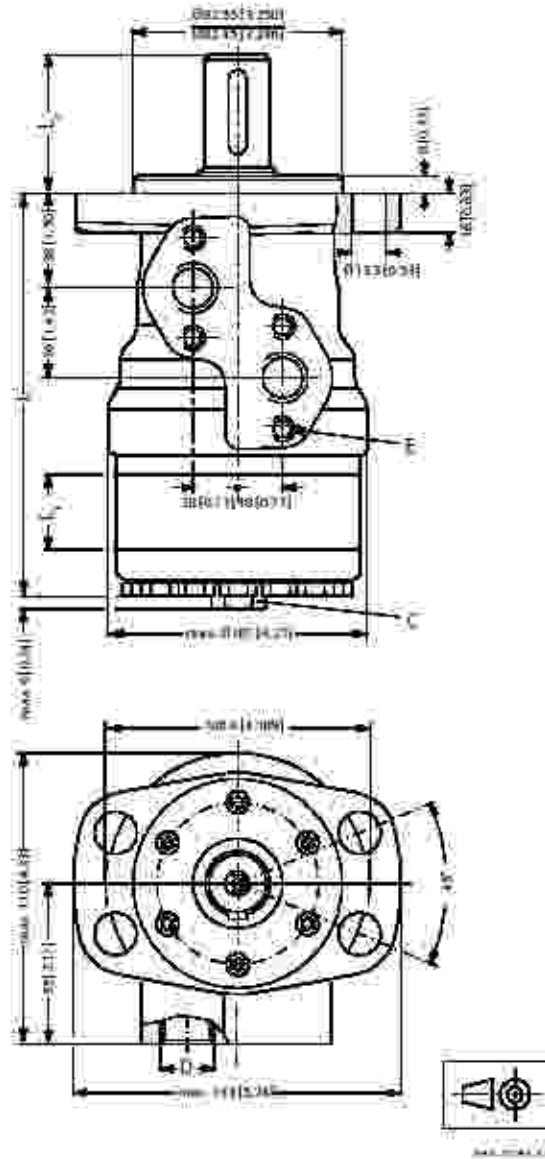

**Dimensions**

Safe port version with 4-hole oval mounting flange (A4-flange)

Type	Max. L, mm [in]	L, mm [in]
OMR 50	136.3 [5.37]	9.0 [0.35]
OMR 80	141.5 [5.57]	14.0 [0.55]
OMR 100	145.0 [5.71]	17.4 [0.69]
OMR 125	149.5 [5.89]	21.6 [0.86]
OMR 160	155.3 [6.12]	27.8 [1.09]
OMR 200	162.5 [6.40]	34.8 [1.37]
OMR 250	171.5 [6.75]	43.5 [1.71]
OMR 315	182.5 [7.19]	54.6 [2.16]
OMR 375	192.7 [7.59]	65.0 [2.56]

- C: Drain connection  
 1/2"-20 UNF;  
 12 mm [0.47 in] deep
- D: 1/8"-31 UNF  
 17 mm [0.66 in] deep
- E: M6; 13 mm [0.51 in] deep  
 (4-off)

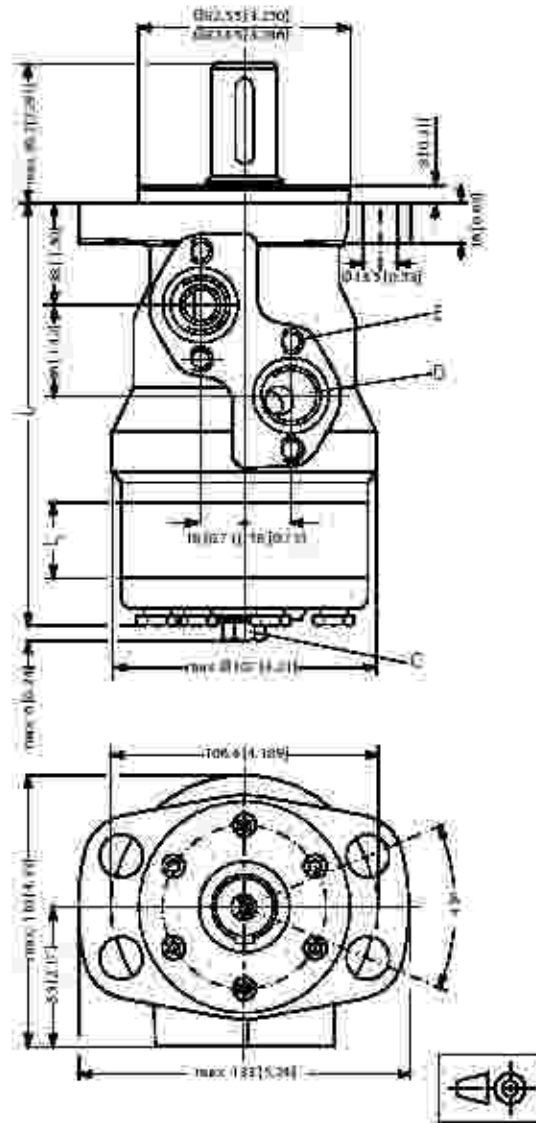

04000000 04

**Dimensions**

End port version with square mounting flange (C-flange)

Type	Max. L mm [in]	L mm [in]
OMR 50	137.6 [5.41]	9.0 [0.35]
OMR 80	162.6 [6.40]	14.0 [0.55]
OMR 100	166.0 [6.54]	17.4 [0.69]
OMR 125	170.4 [6.71]	21.8 [0.86]
OMR 160	176.4 [6.95]	27.8 [1.09]
OMR 200	182.4 [7.18]	34.8 [1.37]
OMR 250	192.1 [7.56]	43.5 [1.71]
OMR 315	203.4 [8.01]	54.8 [2.16]
OMR 375	213.5 [8.41]	65.0 [2.56]

- C: Drain connection  
 GW: 12 mm [0.47 in] deep
- D: G1/2: 15 mm [0.59 in] deep
- E: M10: 15 mm [0.59 in] deep  
 (4 pcs.)

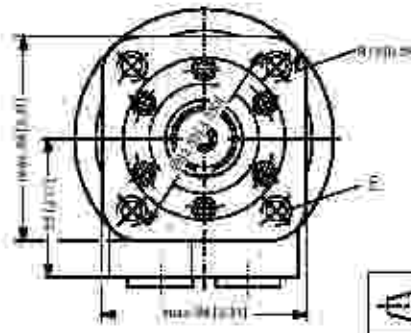
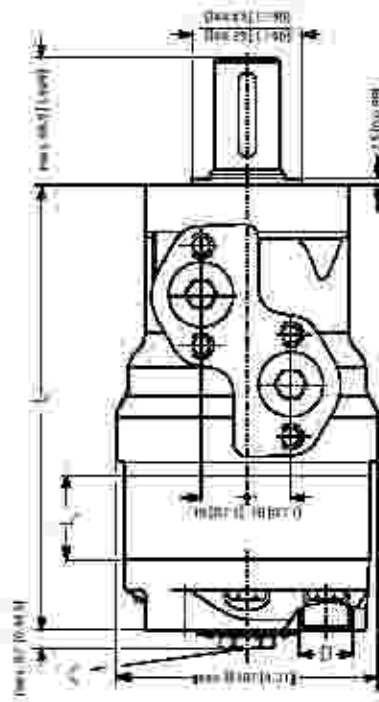
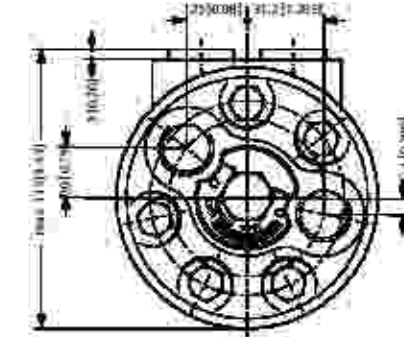

18-1/2011

**Dimensions**

*Safe port version with square mounting flange (C-flange)*

Type	Max. L, mm [in]	L, mm [in]
OMR 50	142.5 [5.61]	9.0 [0.35]
OMR 80	147.5 [5.81]	14.0 [0.55]
OMR 100	151.0 [5.95]	17.4 [0.69]
OMR 125	155.4 [6.12]	21.6 [0.86]
OMR 160	161.5 [6.36]	27.8 [1.09]
OMR 200	168.5 [6.63]	34.8 [1.37]
OMR 250	177.5 [6.99]	43.5 [1.71]
OMR 315	188.5 [7.42]	54.6 [2.16]
OMR 375	198.7 [7.82]	65.0 [2.56]

- C Drain connection  
 $\frac{1}{8}$ "-20 mm UNF  
 12 mm [0.47 in] deep
- D  $\frac{1}{8}$ "-14 UNF  
 17 mm [0.66 in] deep
- E M6, 13 mm [0.51 in] deep (4-off)
- F  $\frac{3}{8}$ "-16 UNC  
 15 mm [0.59 in] deep (4-off)

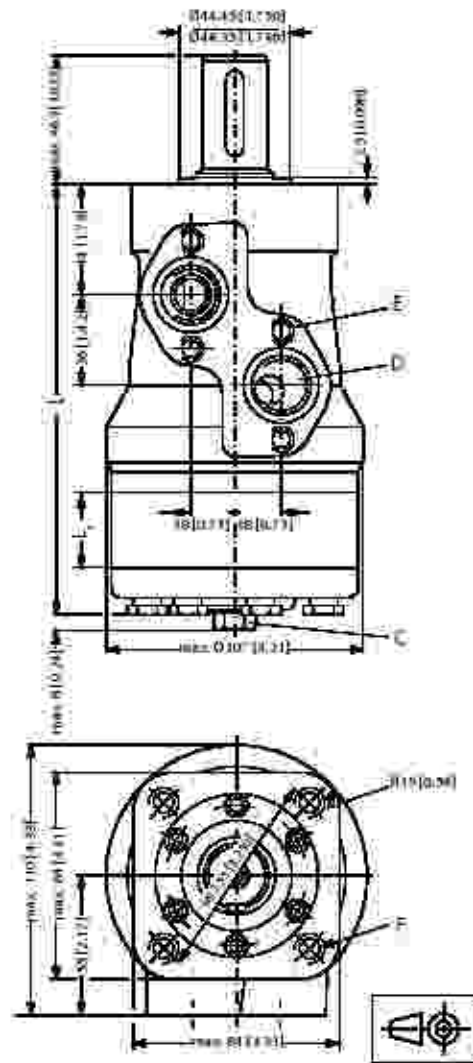

3491208 11

**Dimensions**

OMRW N wheel motor

Type	Max. L mm [in]	L mm [in]
OMRW 50 N	107.0 [4.21]	9.0 [0.35]
OMRW 80 N	112.0 [4.41]	14.0 [0.55]
OMRW 100 N	115.4 [4.54]	17.4 [0.69]
OMRW 125 N	119.6 [4.72]	21.8 [0.86]
OMRW 160 N	125.8 [4.95]	27.8 [1.09]
OMRW 200 N	132.8 [5.23]	34.8 [1.37]
OMRW 250 N	141.5 [5.57]	43.5 [1.71]
OMRW 315 N	153.0 [6.02]	54.8 [2.16]
OMRW 375 N	163.0 [6.42]	65.0 [2.56]

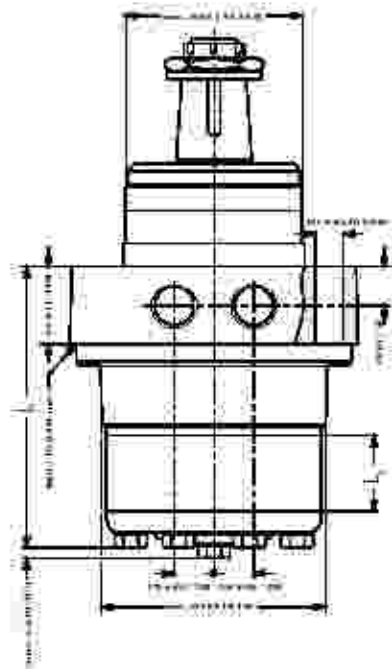
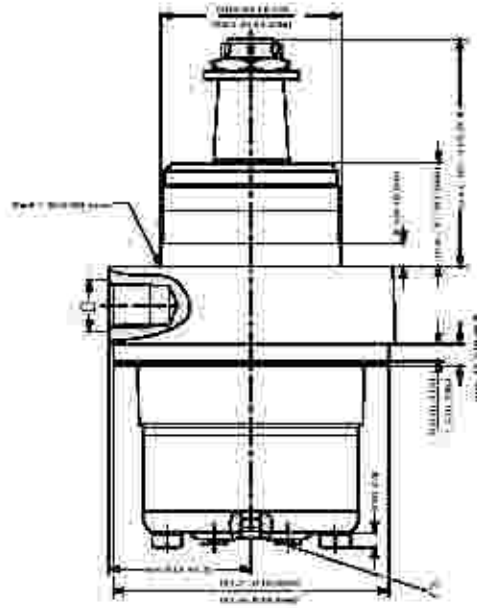

- C: Drain connection  
 G 1/4: 12 mm [0.47 in] deep
- D: G 1/2: 15 mm [0.59 in] deep

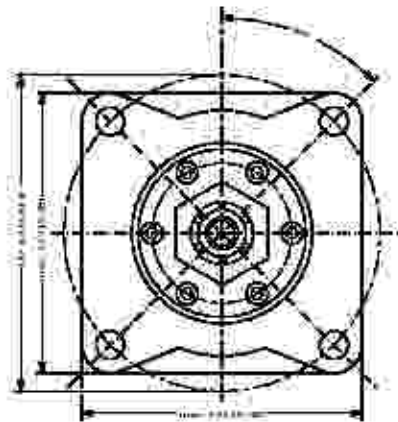

11/1186-11

**Dimensions**

OMRW N wheel motor

Type	Max. L mm [in]	L mm [in]
OMRW 30 N	107.0 [4.21]	9.0 [0.35]
OMRW 80 N	112.0 [4.41]	14.0 [0.55]
OMRW 100 N	113.4 [4.54]	17.4 [0.69]
OMRW 125 N	119.8 [4.72]	21.8 [0.86]
OMRW 180 N	125.8 [4.95]	27.8 [1.09]
OMRW 200 N	132.8 [5.23]	34.8 [1.37]
OMRW 250 N	141.3 [5.57]	43.3 [1.71]
OMRW 315 N	153.0 [6.02]	54.8 [2.16]
OMRW 375 N	163.0 [6.42]	65.0 [2.56]

- Drain connection  
 1/2"-20 UNF  
 12 mm [0.47 in] deep
- D: 1/8"-14 UNF  
 17 mm [0.66 in] deep

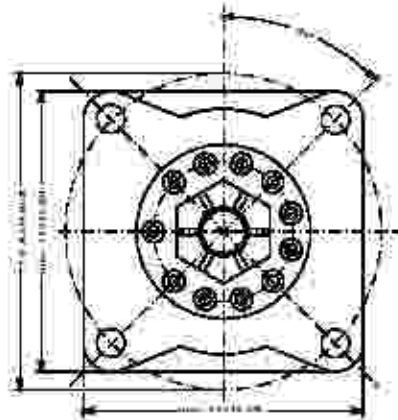
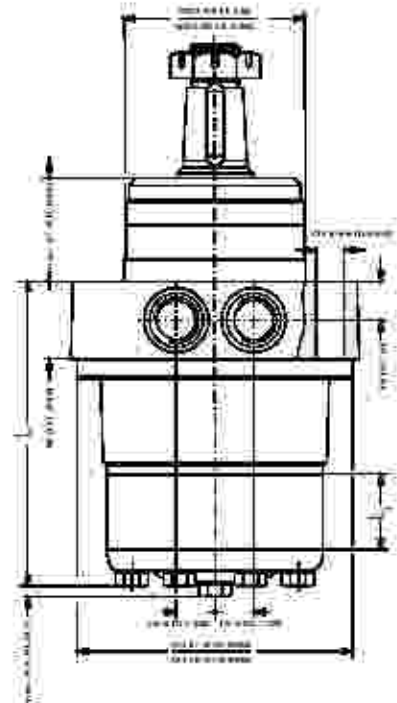
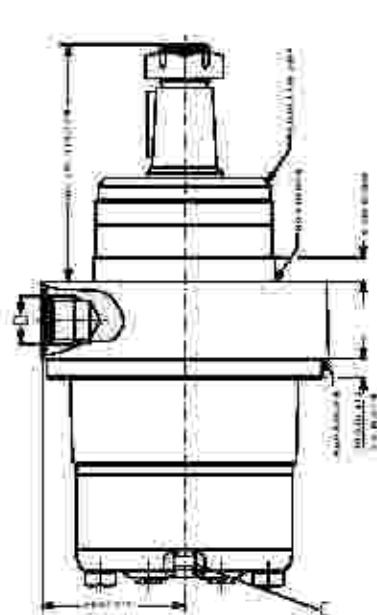

931-1623-11

**Dimensions**

OMR F motor

Type	Max. L, mm [in]	L, mm [in]	L, mm [in]	L, mm [in]
OMR 80 F	241.3 [9.50]	14.0 [0.55]	187.3 [7.37]	210.8 [8.30]
OMR 100 F	244.7 [9.63]	17.4 [0.69]	190.7 [7.51]	214.2 [8.43]
OMR 125 F	249.1 [9.81]	21.8 [0.86]	195.1 [7.68]	218.6 [8.61]
OMR 160 F	255.1 [10.04]	27.8 [1.09]	201.1 [7.92]	224.6 [8.84]
OMR 200 F	262.1 [10.32]	34.8 [1.37]	206.1 [8.12]	231.6 [9.12]
OMR 250 F	270.8 [10.66]	43.3 [1.71]	210.8 [8.30]	240.3 [9.46]
OMR 315 F	282.1 [11.11]	54.8 [2.16]	228.1 [8.98]	251.6 [9.91]
OMR 375 F	292.3 [11.51]	65.0 [2.56]	238.3 [9.38]	263.8 [10.37]

- C: Drain connection  
 G 1/4; 12 mm [0.47 in] deep
- D: G 1/4; 15 mm [0.59 in] deep
- E: M8; 13 mm [0.51 in] deep
- F: 1/2" drive release connection G 1/2"

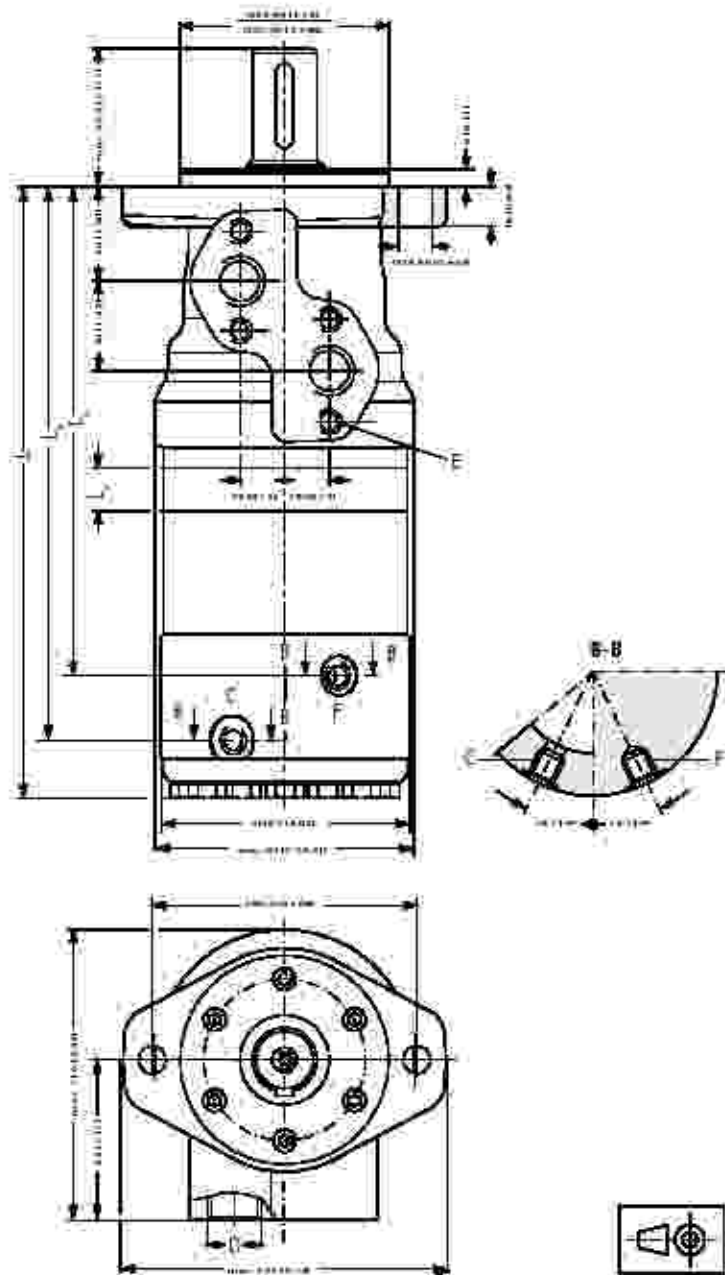

101-D/0311



**Dimensions**

OMR NF motor

Type	Max. L mm (in)	L mm (in)	L mm (in)	L mm (in)
OMR 80 NF	247.3 [9.74]	140 [0.55]	193.3 [7.61]	218.8 [8.59]
OMR 100 NF	250.7 [9.87]	174 [0.69]	196.7 [7.74]	220.2 [8.67]
OMR 125 NF	255.1 [10.04]	218 [0.86]	201.1 [7.92]	224.6 [8.84]
OMR 160 NF	261.1 [10.28]	278 [1.09]	207.1 [8.15]	230.6 [9.08]
OMR 200 NF	268.1 [10.55]	348 [1.37]	214.1 [8.43]	237.6 [9.35]
OMR 250 NF	278.8 [10.96]	435 [1.71]	222.8 [8.77]	246.3 [9.70]
OMR 315 NF	288.1 [11.34]	548 [2.16]	234.1 [9.22]	257.6 [10.14]
OMR 375 NF	298.3 [11.74]	650 [2.56]	244.3 [9.62]	267.8 [10.54]

- C: Drain connection  $\frac{3}{8}$ "-20 UNE
- D:  $\frac{1}{2}$ "-14 UNE 0.66 in (15 mm) deep
- E: M8; 0.51 in (13 mm) deep
- F: Brake release connection  $\frac{3}{8}$ "-20 UNE

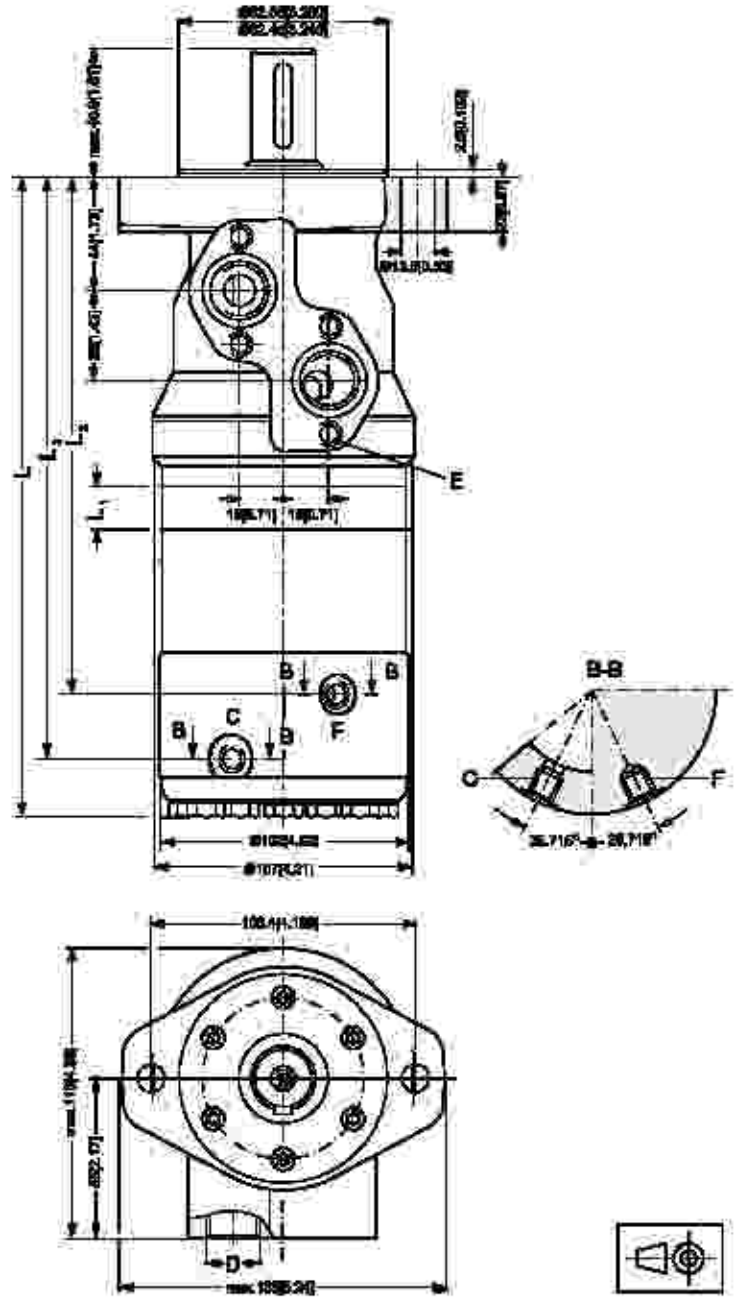

10-1118.11.22

**Dimensions**

OMRW NF motor

Type	Max. L, mm [in]	L, mm [in]
OMRW 60 NF	213.2 [8.39]	14.0 [0.55]
OMRW 100 NF	216.6 [8.53]	17.4 [0.69]
OMRW 125 NF	221.0 [8.70]	21.8 [0.86]
OMRW 160 NF	227.0 [8.94]	27.8 [1.09]
OMRW 200 NF	234.0 [9.21]	34.8 [1.37]
OMRW 250 NF	242.7 [9.56]	43.5 [1.71]
OMRW 315 NF	254.0 [10.0]	54.8 [2.16]
OMRW 375 NF	264.2 [10.40]	65.0 [2.56]

Type	Max. L, mm [in]	L, mm [in]
OMRW 60 NF	159.2 [6.27]	182.7 [7.19]
OMRW 100 NF	162.6 [6.40]	186.1 [7.33]
OMRW 125 NF	167.0 [6.57]	190.5 [7.50]
OMRW 160 NF	173.0 [6.81]	198.5 [7.74]
OMRW 200 NF	180.0 [7.09]	203.5 [8.01]
OMRW 250 NF	188.7 [7.43]	212.2 [8.35]
OMRW 315 NF	200.0 [7.87]	223.5 [8.80]
OMRW 375 NF	210.2 [8.28]	233.7 [9.20]

- C: Drain connection  
 G 1/4, 12 mm [0.47 in] deep
- D: G 1/4, 15 mm [0.59 in] deep
- E: M8, 13 mm [0.51 in] deep
- F: Brake release connection G 1/4

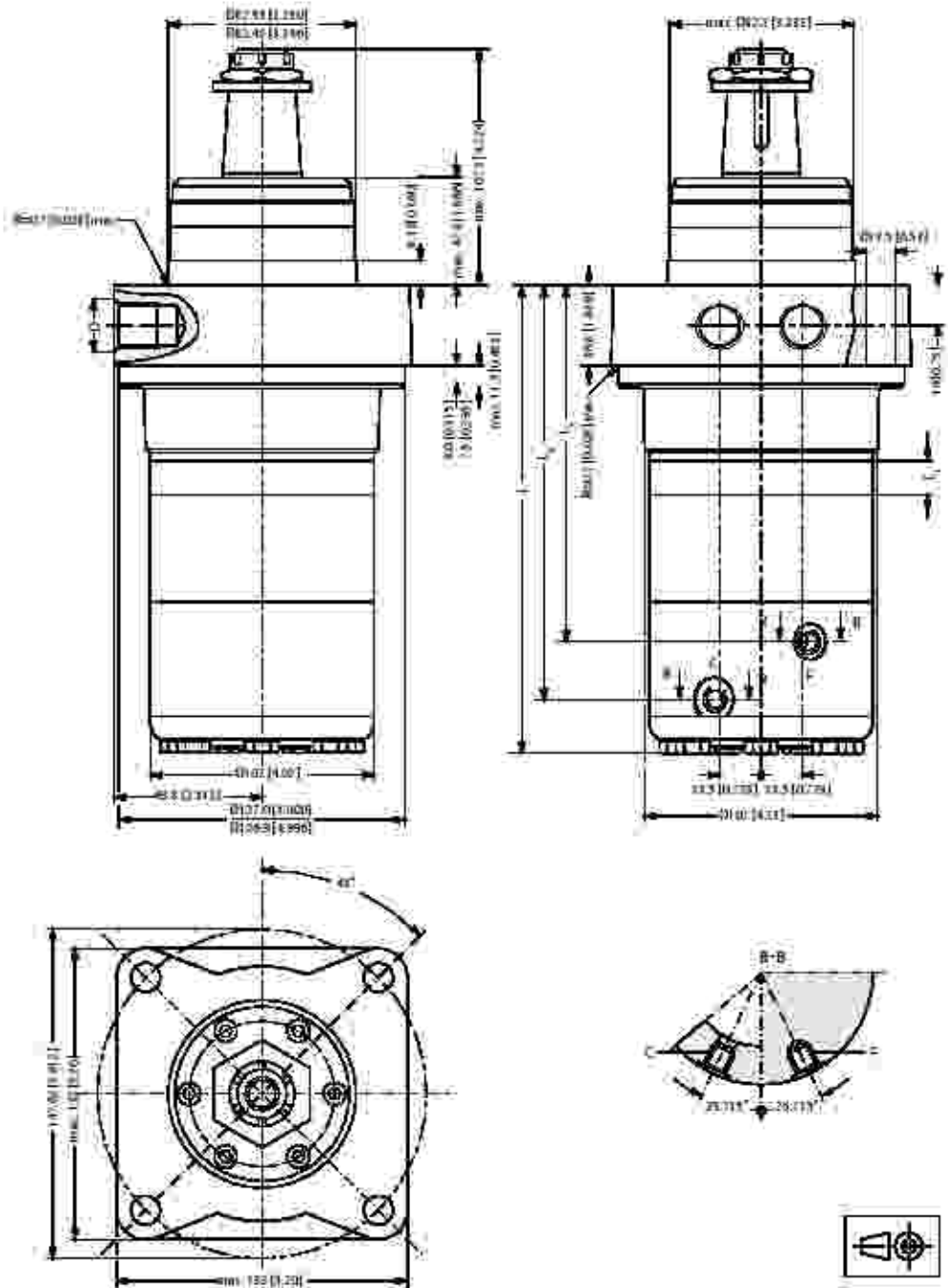



OMR  
Technical Information  
Notes

Notes:

Versions

Mounting flange	Spigot dia meter (front/rear/end)	Bo It circle dia meter (Ø C)	Shaft	Port size	European version	US version	Side port version	End port version	Flange port version	Standard shaft seal	High pressure shaft seal	Drain connection	Check valve	Main type designation	
4 hole oval flange (A4-flange)	Ø 82.5 mm [3.25 in]	Ø 106.4 mm [4.20 in]	Cyl. 52 mm	G 1/2"	●		●			●		Yes	Yes	OMH	
			Cyl. 35 mm	G 3/8"	●		●			●		Yes	Yes	OMH	
			Cyl. 1 1/4 in	1/2-14 UNF		●	●				●		Yes	Yes	OMH
			Splined 110 SAE 08	1/2-14 UNF		●	●				●		Yes	Yes	OMH
			Splined 1 1/4 in	G 1/2"	●		●				●		Yes	Yes	OMH
			Splined 1 1/4 in	1/2-14 UNF		●	●				●		Yes	Yes	OMH
			Tapered 35 mm	G 1/2"	●		●				●		Yes	Yes	OMH
Function diagram - see page: →															



**Code Numbers**

Code numbers	Displacement (cm <sup>3</sup> )					Technical data - Page	Dimensions - Page
	200	250	315	400	500		
151H	1002	1003	1004	1005	1006	79	91
151H	1012	1013	1014	1015	1016	80	91
151H	1042	1043	1044	1045	1046	79	92
151H	1080	1082	1083	1084	1081	78	92
151H	1022	1023	1024	1025	1026	80	91
151H	1052	1053	1054	1055	1056	80	92
151H	-	-	1034	1035	1036	80	91
→	84	84	85	85	86		

**Ordering**

Add the four digit prefix "151H" to the four digit numbers from the chart for complete code number.

**Example:**

151H1044 for an OMH 315 with A4 flange, cyl. 1 1/4 in shaft, port size 7/8-14 UNF

---

Orders will not be accepted without the four digit prefix.

---

Technical data for OMH with T in SAE 6 B splined shaft

Type			OMH	OMH	OMH	OMH	OMH
Motor size			200	250	315	400	500
Geometric displacement	cm <sup>3</sup>		201.3	252.0	314.9	390.8	470.6
	[inch <sup>3</sup> ]		[12.32]	[15.42]	[19.27]	[24.26]	[28.80]
Max. speed	min <sup>-1</sup>	cont.	370	295	235	185	155
		[rpm]					
Max. torque	N·m	cont.	340	340	340	340	340
		[lb-ft]					
		int <sup>1)</sup>	510	510	540	540	520
		peak <sup>2)</sup>	610	610	610	610	610
			[4500]	[4500]	[4800]	[4800]	[4600]
			[5400]	[5400]	[5400]	[5400]	[5400]
Max. output	kW	cont.	11.2	7.5	5.2	4.9	3.7
		[hp]					
		int <sup>1)</sup>	17.2	11.9	9.7	8.2	6.0
			[23.0]	[16.0]	[13.0]	[11.0]	[8.0]
Max. pressure drop	bar	cont.	115	90	75	60	30
		[psi]					
		int <sup>1)</sup>	170	145	120	95	75
		peak <sup>2)</sup>	215	175	145	110	90
			[3120]	[2540]	[2100]	[1600]	[1300]
Max. oil flow	l/min	cont.	75	75	75	75	75
		[US gal/min]					
		int <sup>1)</sup>	90	90	90	90	90
			[23.8]	[23.8]	[23.8]	[23.8]	[23.8]
Max. starting pressure with unloaded shaft	bar		7	7	7	7	7
	[psi]		[100]	[100]	[100]	[100]	[100]
Min. starting torque	at max. press. drop cont.		255	270	280	290	300
	N·m [lb-ft]		[2350]	[2400]	[2500]	[2550]	[2650]
	at max. press. drop int <sup>1)</sup>		390	435	450	450	450
	N·m [lb-ft]		[3450]	[3850]	[4000]	[4000]	[4000]

<sup>1)</sup> Intermittent operation: the permissible values may occur for max. 10% of every minute.

<sup>2)</sup> Peak load: the permissible values may occur for max. 1% of every minute.

Technical data for OMH with 32 mm and 1 1/4 in cylindrical shaft

Type			OMH	OMH	OMH	OMH	OMH
Motor size			200	250	315	400	500
Geometric displacement	cm <sup>3</sup> [inch <sup>3</sup> ]		201.3 [12.32]	252.0 [15.42]	314.9 [19.27]	390.8 [24.28]	470.6 [28.80]
Max. speed	min <sup>-1</sup> [rpm]	cont.	370	295	235	185	155
		int. <sup>1)</sup>	445	350	285	225	190
Max. torque	N·m [lbf·ft]	cont.	510 [370]	610 [440]	590 [430]	390 [280]	580 [420]
		int. <sup>1)</sup>	380 [270]	700 [510]	670 [490]	700 [510]	680 [500]
		peak <sup>2)</sup>	640 [460]	790 [580]	840 [610]	840 [610]	840 [610]
Max. output	kW [hp]	cont.	18.0 [24.3]	18.0 [24.3]	12.5 [16.8]	10.0 [13.4]	8.5 [11.4]
		int. <sup>1)</sup>	18.3 [24.8]	18.3 [24.8]	14.0 [18.8]	12.0 [16.1]	10.0 [13.4]
Max. pressure drop	bar [psi]	cont.	175 [2540]	175 [2540]	135 [1900]	105 [1520]	85 [1230]
		int. <sup>1)</sup>	200 [2900]	200 [2900]	155 [2250]	125 [1810]	100 [1450]
		peak <sup>2)</sup>	225 [3260]	225 [3260]	190 [2760]	155 [2250]	130 [1890]
Max. oil flow	l/min [US gal/min]	cont.	75 [19.8]	75 [19.8]	75 [19.8]	75 [19.8]	75 [19.8]
		int. <sup>2)</sup>	90 [23.8]	90 [23.8]	90 [23.8]	90 [23.8]	90 [23.8]
Max. starting pressure with unloaded shaft	bar [psi]		7 [100]	7 [100]	7 [100]	7 [100]	7 [100]
Min. starting torque	at max. press. drop cont.		390 [280]	520 [380]	510 [370]	490 [360]	490 [360]
	at max. press. drop int. <sup>1)</sup>		450 [320]	590 [430]	590 [430]	600 [440]	600 [440]

<sup>1)</sup> Intermittent operation; the permissible values may occur for max. 10% of every minute.

<sup>2)</sup> Peak load; the permissible values may occur for max. 1% of every minute.

Technical data for OMH with 35 mm cylindrical, 1 1/4 in splined and 35 mm tapered shaft

Type			OMH 200	OMH 250	OMH 315	OMH 400	OMH 500
Motor size			200	250	315	400	500
Geometric displacement	cm <sup>3</sup>		201.3	252.0	314.9	390.8	470.6
	[inch <sup>3</sup> ]		[12.32]	[15.42]	[19.27]	[24.28]	[28.80]
Max. speed	min <sup>-1</sup>	cont.	370	295	235	185	155
		[rpm]					
Max. torque	N·m	cont.	510	610	740	840	820
		[lb-ft]					
		int. <sup>1)</sup>	580	700	820	960	1040
		peak <sup>2)</sup>	640	790	960	1090	1170
			[5600]	[6900]	[8670]	[9650]	[10360]
Max. output	kW	cont.	16.0	16.0	14.0	12.5	11.0
		[hp]					
		int. <sup>1)</sup>	18.5	18.3	15.5	15.0	14.0
			[24.8]	[24.8]	[20.8]	[20.1]	[18.8]
Max. pressure drop	bar	cont.	175	175	175	155	125
		[psi]					
		int. <sup>1)</sup>	200	200	200	190	160
		peak <sup>2)</sup>	225	225	225	210	180
			[3260]	[3260]	[3260]	[3050]	[2610]
Max. oil flow	l/min	cont.	75	75	75	75	75
		[US gal/min]					
		int. <sup>1)</sup>	90	90	90	90	90
			[23.8]	[23.8]	[23.8]	[23.8]	[23.8]
Max. starting pressure with unloaded shaft	bar		7	7	7	7	7
	[psi]		[100]	[100]	[100]	[100]	[100]
Min. starting torque	at max. press. drop cont.		390	520	660	720	720
	N·m [lb-ft]		[3450]	[4600]	[5840]	[6370]	[6370]
	at max. press. drop int. <sup>1)</sup>		450	590	730	880	880
	N·m [lb-ft]		[3900]	[5220]	[6400]	[7790]	[7790]

Type			Max. inlet pressure	Max. return pressure with drain line
OMH 200 - 500	bar	cont.	200	175
	[psi]		[2900]	[2540]
	bar	int. <sup>1)</sup>	225	200
	[psi]		[3260]	[2900]
	bar	peak <sup>2)</sup>	250	225
	[psi]		[3630]	[3260]

<sup>1)</sup> Intermittent operation: the permissible values may occur for max. 10% of every minute.

<sup>2)</sup> Peak load: the permissible values may occur for max. 1% of every minute.



**Max. Permissible Shaft Seal Pressure**

OMH with standard shaft seal, check valves and without use of drain connection:  
 The pressure on the shaft seal never exceeds the pressure in the return line.

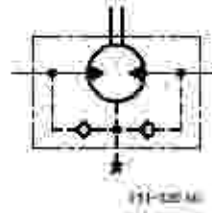

OMH with standard shaft seal, check valves and with drain connection:  
 The shaft seal pressure equals the pressure on the drain line.

Max. return pressure without drain line or max. pressure in the drain line

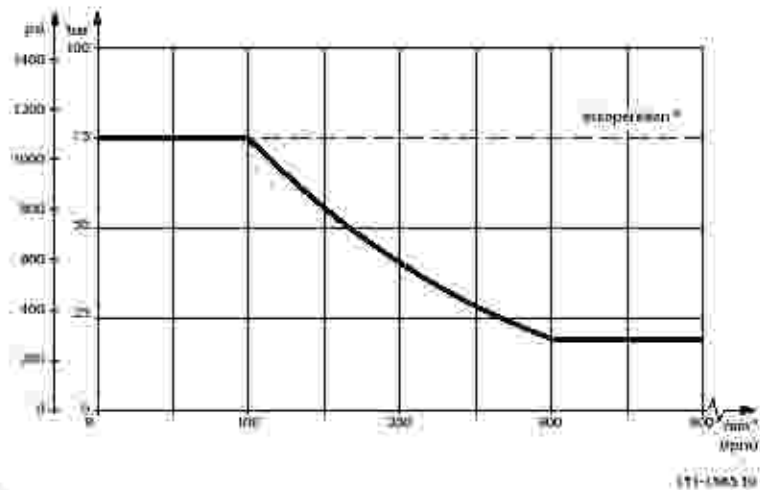

\*Intermittent operation: the permissible values may occur for max. 10% of every minute

**Pressure Drop in Motor**

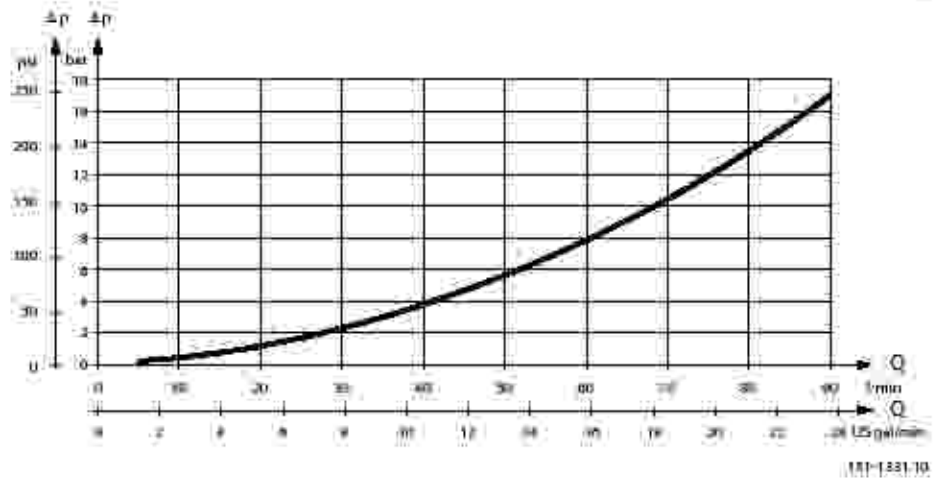

The curve applies to an unloaded motor shaft and an oil viscosity of  $35 \text{ mm}^2/\text{s}$  [65 SUS]

**Oil Flow in Drain Line**

The table shows the max. oil flow in the drain line at a return pressure less than 5-10 bar [73-150 psi]

Pressure drop bar [psi]	Viscosity $\text{mm}^2/\text{s}$ [SUS]	Oil flow in drain line l/min [US gal/min]
100 [1450]	20 [100]	2.5 [0.66]
	35 [165]	1.8 [0.78]
140 [2030]	20 [100]	3.5 [0.93]
	35 [165]	2.8 [0.74]

**Direction of Shaft  
 Rotation**

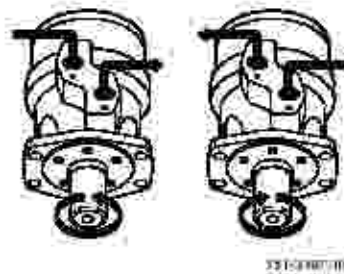

**Permissible Shaft Loads  
 for OMH**

The permissible shaft load ( $P_{\text{rad}}$ ) is calculated from the speed ( $n$ ) and the distance ( $l$ ) between the point of load application and the mounting flange.

$$P_{\text{rad}} = \frac{1100}{n} \cdot \frac{250000}{103.5 + l} \quad \text{N}^*; l \text{ in mm}$$

$$P_{\text{rad}} = \frac{1100}{n} \cdot \frac{2215}{4.07 + l} \quad \text{lbf}^*; l \text{ in inch}$$

\*  $n \geq 200 \text{ min}^{-1} \text{ (rpm)}$ ;  $l \leq 60 \text{ mm [2.36 in]}$   
 $n < 200 \text{ min}^{-1} \text{ (rpm)} \Rightarrow P_{\text{rad}} = 11000 \text{ N [2475 lbf]}$

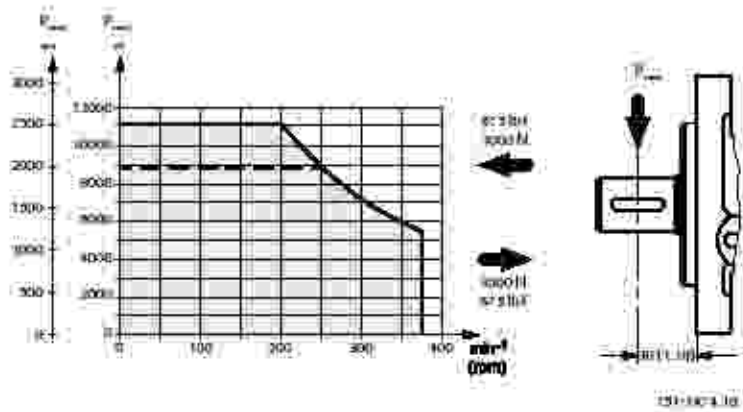

— 1 in SAE 6B splined shaft

The drawing shows the permissible radial load when  $l = 30 \text{ mm [1.18 in]}$ .

Function Diagrams

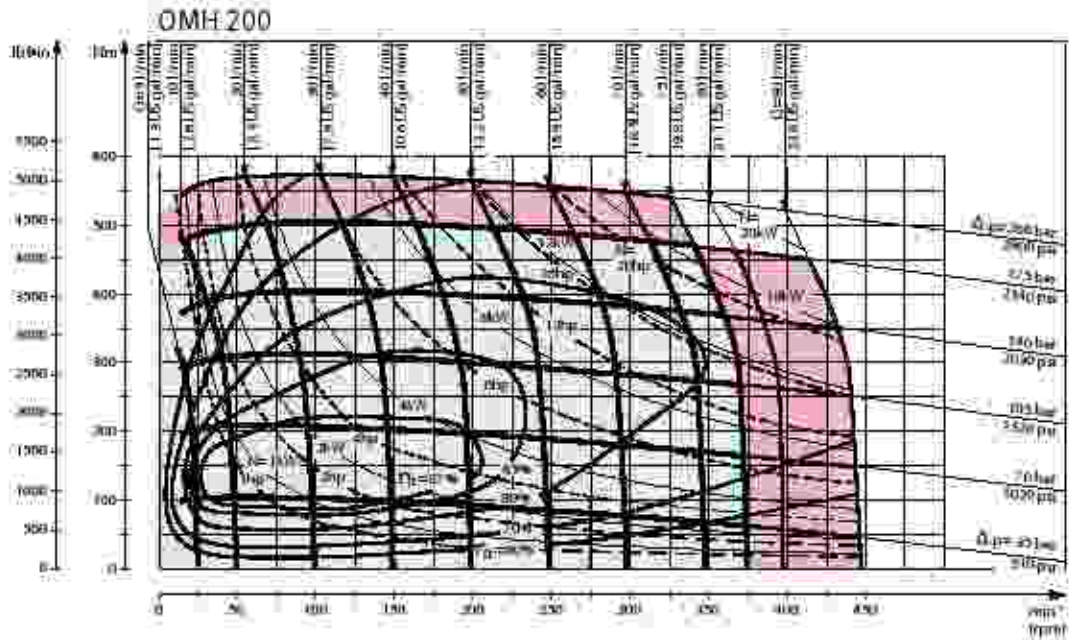

155-1486.00

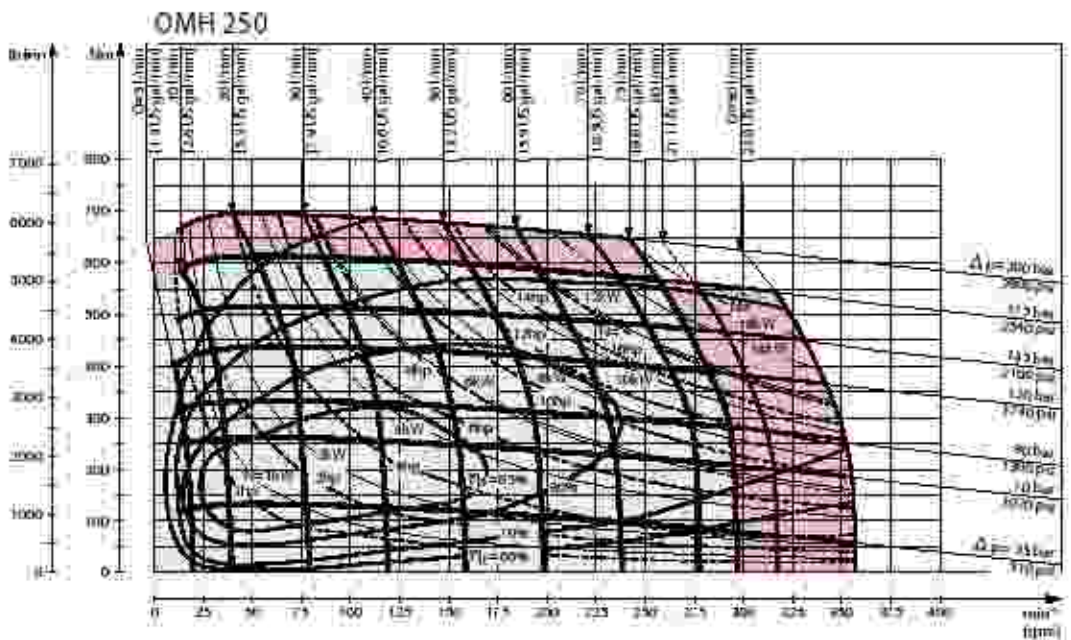

155-1487.10

Explanation of function diagram use, basis and conditions can be found on page 7.

Continuous range

Intermittent range (max. 10% operation every minute)

Max. permissible continuous/intermittent pressure drop for the actual shaft version can be found on page 78-80.

Intermittent pressure drop and oil flow must not occur simultaneously

520L0262 · Rev C · Nov 2012

Function Diagrams

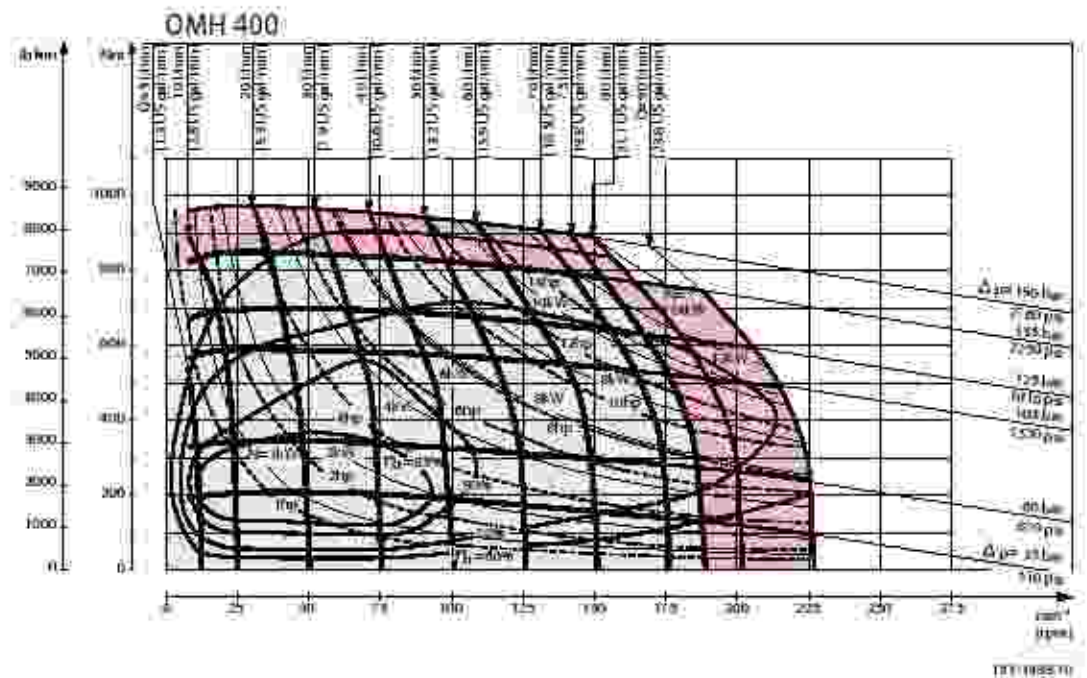
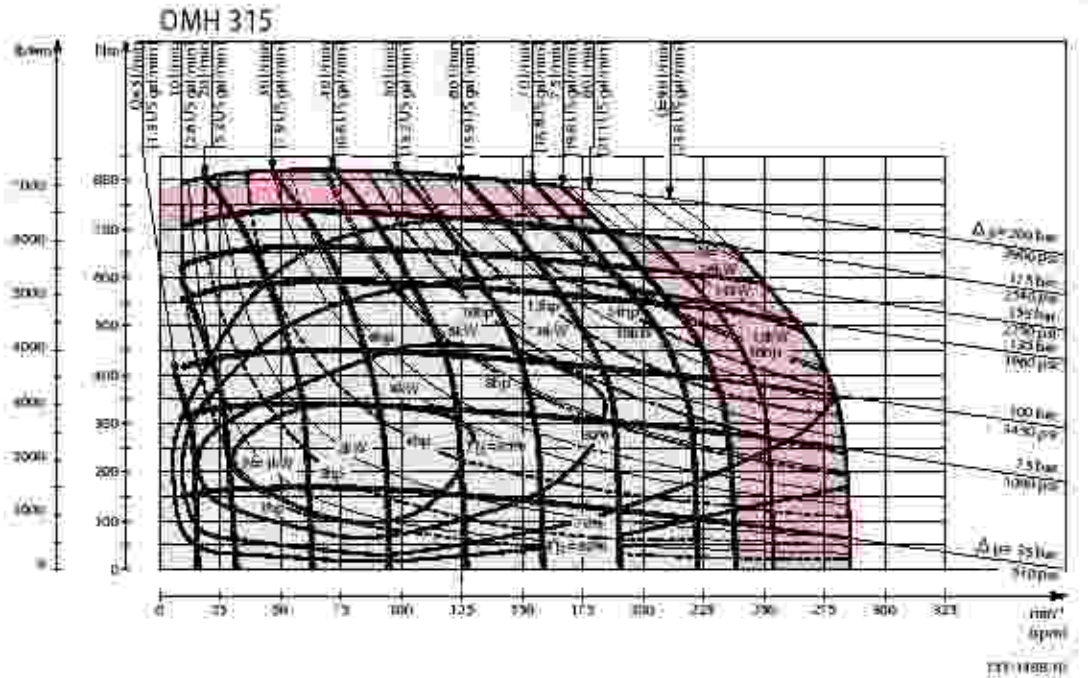

Explanation of function diagram use, basis and conditions can be found on page 7.

Continuous range

Intermittent range (max. 10% operation every minute) Max. permissible continuous/intermittent pressure drop for the actual shaft version can be found on page 78 - 80.

Intermittent pressure drop and oil flow must not occur simultaneously.

Function Diagrams

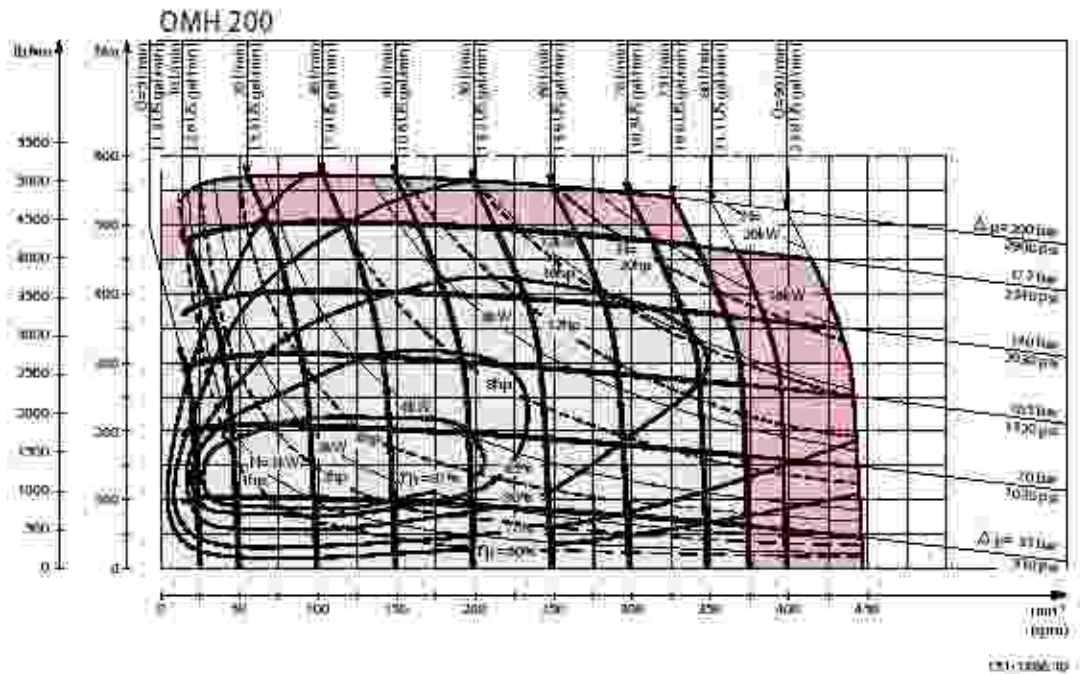

Explanation of function diagram use, basis and conditions can be found on page 7.

☐ Continuous range

■ Intermittent range (max. 10% operation every minute)

Max. permissible continuous/intermittent pressure drop for the actual shaft version can be found on page 78- 80.

---

Intermittent pressure drop and oil flow must not occur simultaneously.

---

**Shaft Version**

- A: Cylindrical shaft 32 mm  
 D: Parallel key  
 A 10 × 8 × 45  
 DIN 6885

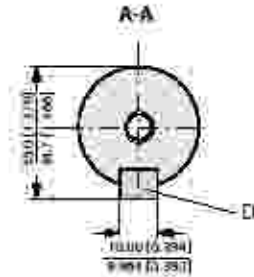
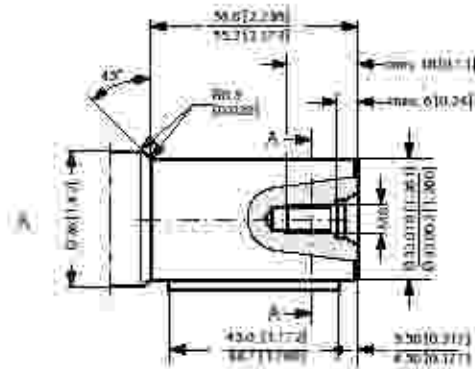

- B: Cylindrical shaft 33 mm  
 E: Parallel key  
 A 10 × 8 × 45  
 DIN 6885

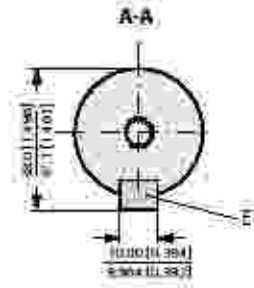
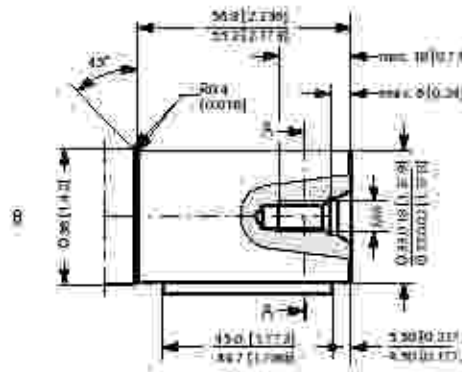

- US version**  
 C: Cylindrical shaft 1 1/4 in.  
 F: Parallel key  
 M 16 × 7/16 × 1 1/4 in.  
 SAE J 794

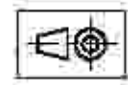
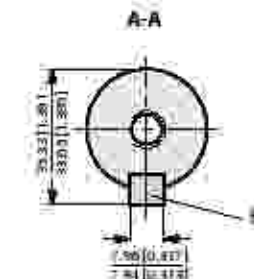
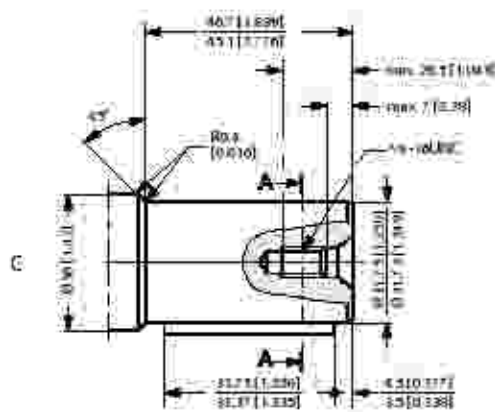

**Shaft Version**

D: Splined shaft  
 SAE 6 B (B.S. 2059)  
 Straight-sided,  
 bottom fitting, deep,  
 Fit 2  
 Nom. size 1 in

\*Deviate from  
 SAE 6 B (B.S. 2059)

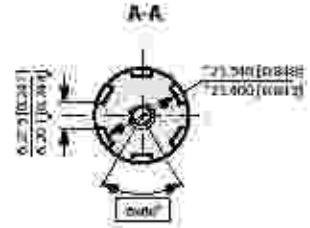
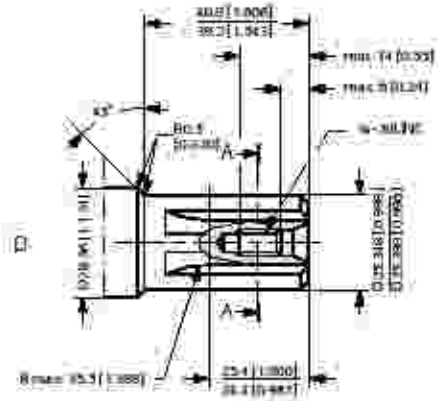

E: Involute splined shaft  
 ANSI 92.1 - 1980 standard  
 Flat root side fit  
 Pitch 12/24  
 Teeth 14  
 Major dia. 1.25 in  
 Pressure angle 30°

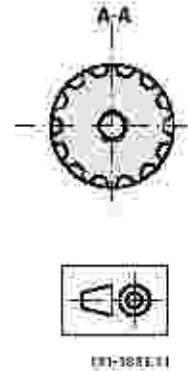
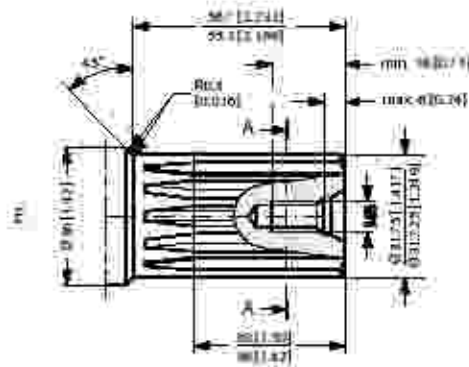



**Shaft Version**

**US version**

- F: Involute splined shaft
- ANS B92.1 - 1970 standard
- Flat root side fit
- Pitch 12/24
- Teeth 14
- Major dia. 1.25 in
- Pressure angle 30°

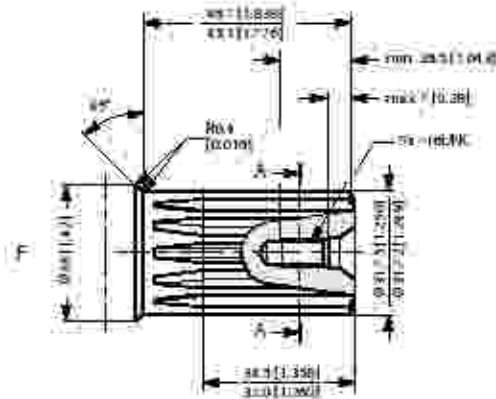

- G: Tapered shaft 35 mm
- F: DIN 937
- NV 41
- Tightening torque: 200 ± 10 N·m [1770 ± 85 lbf·in]
- H: Taper: 1:10
- L: Parallel key
- B6 - 6 - 20
- DIN 6885

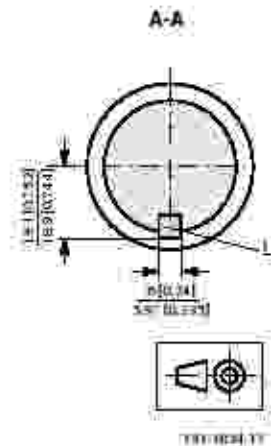
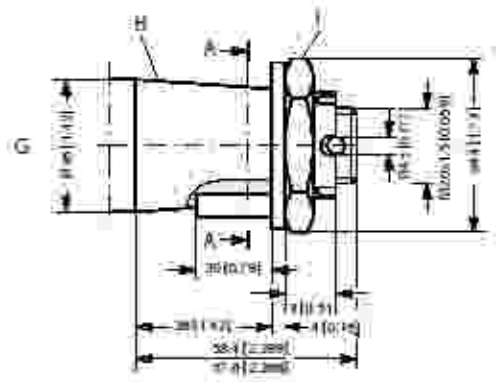

Port Thread Versions

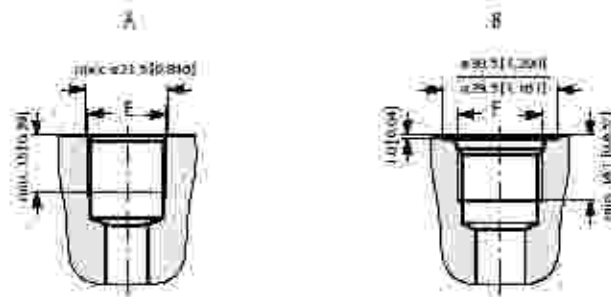

A: G main ports      B: UNF main ports  
 E: ISO 228/1 - G/2      F: 7/8 - 14 UNF  
 O-ring boss port

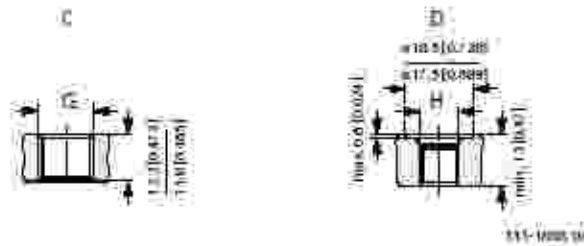

C: G drain port      D: UNF drain port  
 G: ISO 228/1 - G/4      H: 7/8 - 20 UNF  
 O-ring boss port

Manifold Mount

European version

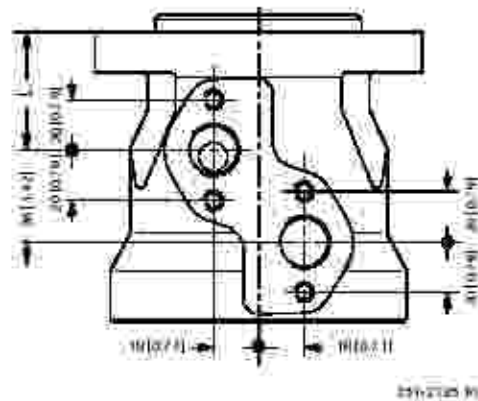

L: see dimensional drawing for given OMH motor on pages 91 - 92

**Dimensions**

Side port version with 4 hole oval mounting flange (A4-flange)

Type	Max. L mm [in]	L mm [in]
OMH 200	171.1 [6.74]	278 [1.09]
OMH 250	178.1 [7.01]	348 [1.37]
OMH 315	186.8 [7.35]	415 [1.63]
OMH 400	198.1 [7.80]	548 [2.16]
OMH 500	208.3 [8.20]	650 [2.56]

C: Drain connection  
 G 1/4: 12 mm [0.47 in] deep  
 D: G 3/2: 15 mm [0.59 in] deep

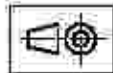
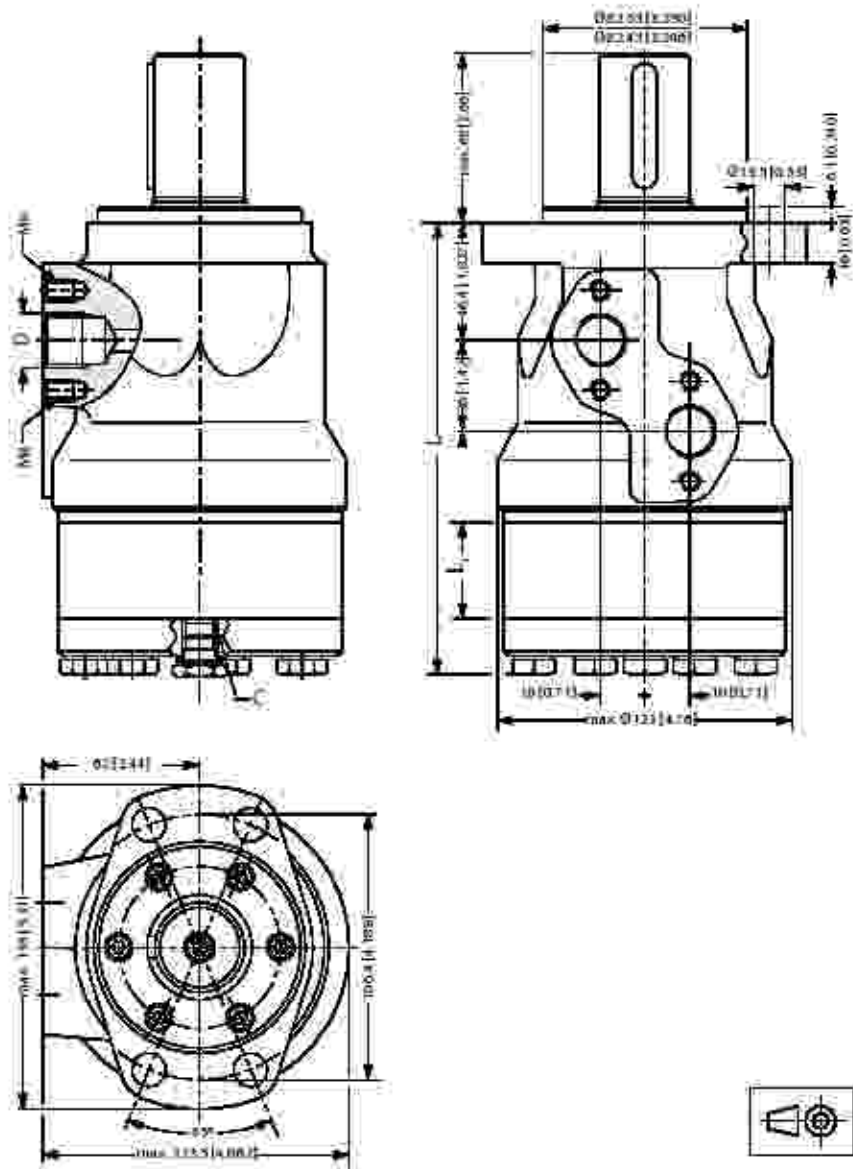

155-1938.01

**Dimensions**

Side port version with 4 hole oval mounting flange (A# flange)

Output shaft max.	mm [in]
Splined shaft 1 in.	30.5 [1.99]
Other shaft versions	58.0 [2.28]

Type	Max. L mm [in]	L mm [in]
OMH 200	171.1 [6.74]	27.8 [1.09]
OMH 250	178.1 [7.01]	34.5 [1.37]
OMH 315	186.8 [7.35]	43.5 [1.71]
OMH 400	198.1 [7.80]	54.8 [2.16]
OMH 500	208.3 [8.20]	65.0 [2.56]

- C: Drain connection  
278 - 20 UNF  
12 mm [0.47 in] deep
- D: 7/8 - 14 UNF  
15 mm [0.59 in] deep

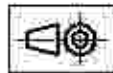
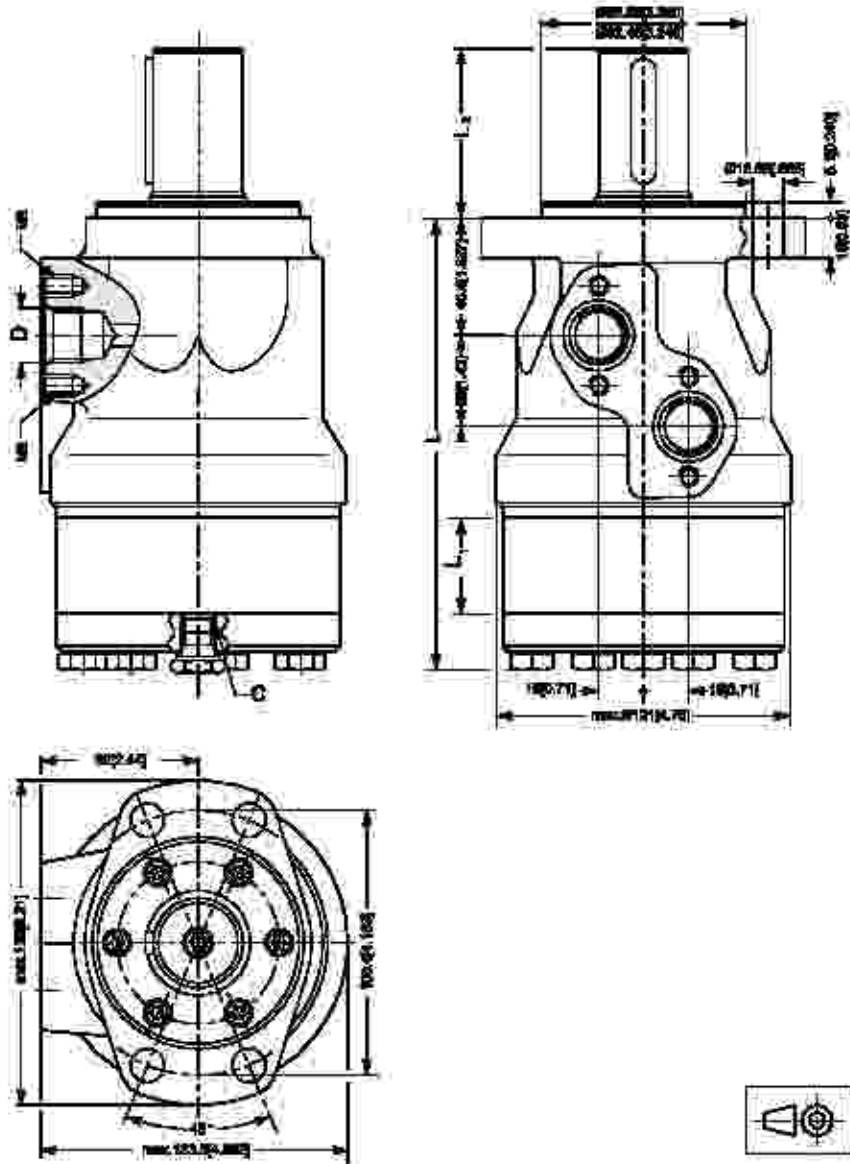

921-1204-11-22

Weight of Motors

Code no	Weight	
	kg	[lb]
151-0208	7.2	[15.9]
151-0242	8.9	[19.3]
151-0243	7.0	[15.4]
151-0244	7.3	[16.3]
151-0245	8.0	[17.6]
151-0246	9.0	[19.8]
151-0247	8.3	[18.3]
151-0248	6.7	[14.8]
151-0265	6.7	[14.8]
151-0266	6.9	[15.2]
151-0267	7.0	[15.4]
151-0268	7.3	[16.3]
151-0269	8.0	[17.6]
151-0270	9.0	[19.8]
151-0271	8.5	[18.7]
151-0300	5.6	[12.3]
151-0301	5.7	[12.6]
151-0302	5.9	[13.0]
151-0303	6.0	[13.2]
151-0304	6.2	[13.7]
151-0305	6.4	[14.1]
151-0306	6.6	[14.6]
151-0307	6.9	[15.2]
151-0308	7.4	[16.3]
151-0310	5.6	[12.3]
151-0311	5.7	[12.6]
151-0312	5.9	[13.0]
151-0313	6.0	[13.2]
151-0314	6.2	[13.7]
151-0315	6.4	[14.1]
151-0316	6.6	[14.6]
151-0317	6.9	[15.2]
151-0318	7.4	[16.3]
151-0319	5.6	[12.3]
151-0320	5.6	[12.3]
151-0321	5.7	[12.6]
151-0322	5.9	[13.0]
151-0323	6.0	[13.2]
151-0324	6.2	[13.7]
151-0325	6.4	[14.1]
151-0326	6.6	[14.6]
151-0327	6.9	[15.2]
151-0328	7.4	[16.3]
151-0329	6.6	[14.6]
151-0330	6.8	[14.9]
151-0331	6.9	[15.2]
151-0332	7.4	[16.3]
151-0333	5.3	[11.7]
151-0334	5.3	[11.7]
151-0335	5.4	[11.9]
151-0336	6.8	[14.9]
151-0337	6.9	[15.2]
151-0338	7.4	[16.3]
151-0340	5.3	[11.7]
151-0341	5.3	[11.7]
151-0342	5.6	[12.3]
151-0400	6.7	[14.8]
151-0401	6.9	[15.2]
151-0402	7.0	[15.4]
151-0403	7.2	[15.9]
151-0404	7.5	[16.5]

Code no	Weight	
	kg	[lb]
151-0405	8.0	[17.6]
151-0406	8.3	[18.3]
151-0407	9.0	[19.8]
151-0408	9.5	[20.9]
151-0410	6.7	[14.8]
151-0411	6.9	[15.2]
151-0412	7.0	[15.4]
151-0413	7.2	[15.9]
151-0414	7.3	[16.3]
151-0415	8.0	[17.6]
151-0416	8.5	[18.7]
151-0417	9.0	[19.8]
151-0418	9.5	[20.9]
151-0420	6.7	[14.8]
151-0421	6.9	[15.2]
151-0422	7.0	[15.4]
151-0423	7.2	[15.9]
151-0424	7.5	[16.5]
151-0425	8.0	[17.6]
151-0426	8.5	[18.7]
151-0427	9.0	[19.8]
151-0428	9.5	[20.9]
151-0600	5.6	[12.3]
151-0601	5.7	[12.6]
151-0602	5.9	[13.0]
151-0603	6.0	[13.2]
151-0604	6.2	[13.7]
151-0605	6.4	[14.1]
151-0606	6.6	[14.6]
151-0607	6.9	[15.2]
151-0608	7.4	[16.3]
151-0610	5.6	[12.3]
151-0611	5.7	[12.6]
151-0612	5.9	[13.0]
151-0613	6.0	[13.2]
151-0614	6.2	[13.7]
151-0615	6.4	[14.1]
151-0616	6.6	[14.6]
151-0617	6.9	[15.2]
151-0618	7.4	[16.3]
151-0622	5.9	[13.0]
151-0624	6.2	[13.7]
151-0625	6.4	[14.1]
151-0627	6.9	[15.2]
151-0628	5.6	[12.3]
151-0631	5.7	[12.6]
151-0632	5.9	[13.0]
151-0633	6.0	[13.2]
151-0634	6.2	[13.7]
151-0635	6.4	[14.1]
151-0636	6.6	[14.6]

Code no	Weight	
	kg	[lb]
151-0637	6.9	[15.2]
151-0638	7.4	[16.3]
151-0640	5.3	[11.7]
151-0641	5.3	[11.7]
151-0642	5.6	[12.3]
151-0646	5.9	[13.0]
151-0700	6.7	[14.8]
151-0701	6.9	[15.2]
151-0702	7.0	[15.4]
151-0703	7.2	[15.9]
151-0704	7.3	[16.3]
151-0705	8.0	[17.6]
151-0706	8.5	[18.7]
151-0707	9.0	[19.8]
151-0708	9.5	[20.9]
151-0710	6.7	[14.8]
151-0711	6.9	[15.2]
151-0712	7.0	[15.4]
151-0713	7.2	[15.9]
151-0714	7.3	[16.3]
151-0715	8.0	[17.6]
151-0716	8.5	[18.7]
151-0717	9.0	[19.8]
151-0718	9.5	[20.9]
151-0720	6.7	[14.8]
151-0721	6.9	[15.2]
151-0722	7.0	[15.4]
151-0723	7.2	[15.9]
151-0724	7.3	[16.3]
151-0725	8.0	[17.6]
151-0726	8.5	[18.7]
151-0727	9.0	[19.8]
151-0728	9.5	[20.9]
151-1208	5.6	[12.3]
151-1209	5.7	[12.6]
151-1210	5.9	[13.0]
151-1211	6.0	[13.2]
151-1212	6.2	[13.7]
151-1213	6.4	[14.1]
151-1214	6.6	[14.6]
151-1215	6.9	[15.2]
151-1216	7.4	[16.3]
151-1217	6.0	[13.2]
151-1221	6.7	[14.8]
151-1222	6.9	[15.2]
151-1223	7.0	[15.4]
151-1224	7.3	[16.3]
151-1225	8.0	[17.6]
151-1226	8.5	[18.7]
151-1227	9.0	[19.8]
151-1228	7.2	[15.9]
151-1243	9.5	[20.9]

Weight of Motors

Code no	Weight	
	kg	(lb)
151-5001	5.6	[12.3]
151-5002	5.7	[12.6]
151-5003	5.9	[13.0]
151-5004	6.0	[13.2]
151-5005	6.2	[13.7]
151-5006	6.4	[14.1]
151-5007	6.6	[14.6]
151-5008	6.9	[15.2]
151-5009	7.4	[16.3]
151-5010	5.4	[11.9]
151-5174	5.4	[11.9]
151-5191	6.1	[13.4]
151-5192	6.2	[13.7]
151-5193	6.4	[14.1]
151-5194	6.5	[14.3]
151-5195	6.7	[14.8]
151-5196	6.9	[15.2]
151-5197	7.1	[15.7]
151-5198	7.4	[16.3]
151-5199	7.9	[17.4]
151-5211	5.5	[12.1]
151-5212	5.6	[12.3]
151-5213	5.8	[12.8]
151-5214	5.9	[13.0]
151-5215	6.1	[13.4]
151-5216	6.3	[13.9]
151-5217	6.5	[14.3]
151-5218	6.8	[15.0]
151-5219	7.3	[16.1]
151-5301	5.5	[12.1]
151-5302	5.6	[12.3]
151-5303	5.8	[12.8]
151-5304	5.9	[13.0]
151-5305	6.1	[13.4]
151-5306	6.3	[13.9]
151-5307	6.5	[14.3]
151-5308	6.8	[15.0]
151-5309	7.3	[16.1]
151-5311	5.6	[12.3]
151-5312	5.7	[12.6]
151-5313	5.9	[13.0]
151-5315	6.2	[13.7]
151-5316	6.4	[14.1]
151-5318	6.6	[14.6]
151-6000	6.7	[14.8]
151-6001	6.8	[15.2]
151-6002	7.0	[15.4]
151-6003	7.2	[15.9]
151-6004	7.5	[16.5]
151-6005	8.0	[17.6]
151-6006	8.5	[18.7]

Code no	Weight	
	kg	(lb)
151-6007	9.0	[19.8]
151-6008	9.5	[20.9]
151-6010	6.7	[14.8]
151-6011	6.8	[15.2]
151-6012	7.0	[15.4]
151-6013	7.2	[15.9]
151-6014	7.5	[16.5]
151-6015	8.0	[17.6]
151-6016	8.5	[18.7]
151-6017	9.0	[19.8]
151-6018	9.5	[20.9]
151-6110	6.7	[14.8]
151-6111	6.9	[15.2]
151-6112	7.0	[15.4]
151-6113	7.2	[15.9]
151-6114	7.5	[16.5]
151-6115	8.0	[17.6]
151-6116	8.5	[18.7]
151-6117	9.0	[19.8]
151-6118	9.5	[20.9]
151-6190	7.3	[16.1]
151-6191	7.5	[16.5]
151-6192	7.6	[16.8]
151-6193	7.8	[17.2]
151-6194	8.1	[17.9]
151-6195	8.6	[19.0]
151-6196	9.1	[20.1]
151-6197	9.6	[21.2]
151-6198	10.1	[22.3]
151-6210	6.7	[14.8]
151-6211	6.9	[15.2]
151-6212	7.0	[15.4]
151-6213	7.2	[15.9]
151-6214	7.5	[16.5]
151-6215	8.0	[17.6]
151-6216	8.5	[18.7]
151-6217	9.0	[19.8]
151-6218	9.5	[20.9]
151-6294	6.5	[14.3]
151-6295	7.2	[15.9]
151-6296	8.5	[20.9]
151-6300	9.0	[19.8]
151-6301	9.4	[20.7]
151-6302	9.5	[20.9]
151-6303	9.7	[21.4]
151-6304	10.0	[22.1]
151-6305	10.5	[23.1]
151-6306	11.0	[24.3]
151-6307	11.5	[25.4]
151-6308	12.0	[26.5]
151-6380	6.7	[14.8]

Code no	Weight	
	kg	(lb)
151-6381	6.9	[15.2]
151-6382	7.2	[15.9]
151-6384	7.5	[16.5]
151-6385	8.0	[17.6]
151-6386	8.5	[18.7]
151-6387	9.0	[19.8]
151-6388	9.5	[20.9]
151-6430	9.0	[19.8]
151-6431	9.4	[20.7]
151-6432	9.5	[20.9]
151-6433	9.7	[21.4]
151-6434	10.0	[22.1]
151-6435	10.5	[23.1]
151-6436	11.0	[24.3]
151-6437	11.5	[25.4]
151-6438	12.0	[26.5]
151-6442	14.5	[32.0]
151-6443	14.7	[32.4]
151-6444	15.0	[33.1]
151-6445	15.5	[34.2]
151-6461	11.5	[25.4]
151-6462	12.0	[26.5]
151-6463	12.0	[26.5]
151-6464	12.5	[27.6]
151-6465	12.5	[27.6]
151-6466	13.0	[28.7]
151-6467	13.5	[29.8]
151-6468	14.0	[30.9]
151-6471	11.5	[25.4]
151-6472	12.0	[26.5]
151-6473	12.0	[26.5]
151-6474	12.5	[27.6]
151-6475	12.5	[27.6]
151-6476	13.0	[28.7]
151-6477	13.5	[29.8]
151-6478	14.0	[30.9]
151-7021	5.0	[11.0]
151-7022	5.1	[11.2]
151-7023	5.3	[11.7]
151-7024	5.4	[11.9]
151-7025	5.6	[12.3]
151-7026	5.8	[12.8]
151-7027	6.0	[13.2]
151-7028	6.3	[13.9]
151-7029	6.8	[15.0]
151-7041	5.6	[12.3]
151-7042	5.7	[12.6]
151-7043	5.9	[13.0]
151-7044	5.4	[11.9]
151-7045	6.2	[13.7]
151-7046	6.4	[14.1]

Weight of Motors

Code no	Weight	
	kg	(lb)
151-7047	6.8	[14.6]
151-7048	8.9	[19.2]
151-7049	7.4	[16.3]
151-7061	5.0	[11.0]
151-7062	5.1	[11.2]
151-7063	5.3	[11.7]
151-7065	5.6	[12.3]
151-7066	5.8	[12.8]
151-7067	6.0	[13.2]
151-7080	6.3	[13.9]
151-7089	6.8	[15.0]
151-7080	5.4	[12.0]
151-7081	5.4	[12.0]
151-7082	5.6	[12.3]
151-7101	5.5	[12.1]
151-7102	5.6	[12.3]
151-7103	5.8	[12.8]
151-7104	5.9	[13.0]
151-7105	6.1	[13.4]
151-7106	6.3	[13.9]
151-7107	6.5	[14.3]
151-7108	6.8	[15.0]
151-7109	7.3	[16.1]
151-7240	6.7	[14.8]
151-7241	6.9	[15.2]
151-7242	7.0	[15.4]
151-7243	7.2	[15.9]
151-7244	7.5	[16.5]
151-7245	8.0	[17.6]
151-7246	8.5	[18.7]
151-7247	9.0	[19.8]
151-7248	9.5	[20.9]
151-7250	6.7	[14.8]
151-7251	6.9	[15.2]
151-7252	7.0	[15.4]
151-7253	7.2	[15.9]
151-7254	7.5	[16.5]
151-7255	8.0	[17.6]
151-7256	8.5	[18.7]
151-7257	9.0	[19.8]
151-7258	9.5	[20.9]
151-7260	6.1	[13.4]
151-7261	6.3	[13.9]
151-7262	6.4	[14.1]
151-7263	6.6	[14.6]
151-7264	6.9	[15.2]
151-7265	7.4	[16.3]
151-7266	7.9	[17.4]
151-7267	8.4	[18.5]
151-7269	8.9	[19.6]
151H1002	10.5	[23.1]

Code no	Weight	
	kg	(lb)
151H1003	11.0	[24.3]
151H1004	11.3	[25.4]
151H1005	12.3	[27.1]
151H1006	13.0	[28.7]
151H1012	10.5	[23.1]
151H1013	11.0	[24.3]
151H1014	11.3	[25.4]
151H1015	12.3	[27.1]
151H1016	13.0	[28.7]
151H1022	10.5	[23.1]
151H1023	11.0	[24.3]
151H1024	11.5	[25.4]
151H1025	12.3	[27.1]
151H1026	13.0	[28.7]
151H1034	11.5	[25.4]
151H1035	12.3	[27.1]
151H1036	13.0	[28.7]
151H1042	10.5	[23.1]
151H1043	11.0	[24.3]
151H1044	11.5	[25.4]
151H1045	12.3	[27.1]
151H1046	13.0	[28.7]
151H1052	10.5	[23.1]
151H1053	11.0	[24.3]
151H1054	11.5	[25.4]
151H1055	12.3	[27.1]
151H1056	13.0	[28.7]
151H1080	10.5	[23.1]
151H1081	13.0	[28.7]
151H1082	11.0	[24.3]
151H1083	11.5	[25.4]
151H1084	12.3	[27.1]



#### Products we offer:

- Bent-Axis Motors
- Closed-Circuit Axial Piston Pumps and Motors
- Displays
- Electrohydraulic Power Steering
- Electrohydraulics
- Hydraulic Power Steering
- Integrated Systems
- Joysticks and Control Handles
- Microcontrollers and Software
- Open Circuit Axial Piston Pumps
- Orbital Motors
- PLUS+1™ GUIDE
- Proportional Valves
- Sensors
- Steering
- Transit Mixer Drives

#### Members of the Sauer-Danfoss Group:

**Comatrol**  
[www.comatrol.com](http://www.comatrol.com)

**Schwarz Müller-Inverter**  
[www.schwarzmueller-inverter.com](http://www.schwarzmueller-inverter.com)

**Turolia**  
[www.turolia.co.jp](http://www.turolia.co.jp)

**Valmova**  
[www.valmova.com](http://www.valmova.com)

**Hydro-Gear**  
[www.hydro-gear.com](http://www.hydro-gear.com)

**Sauer-Danfoss-Daikin**  
[www.sauer-danfoss-daikin.com](http://www.sauer-danfoss-daikin.com)

**Sauer-Danfoss** is a global manufacturer and supplier of high-quality hydraulic and electronic components. We specialize in providing state-of-the-art technology and solutions that excel in the harsh operating conditions of the mobile off-highway market. Building on our extensive applications expertise, we work closely with our customers to ensure exceptional performance for a broad range of off-highway vehicles.

We help OEMs around the world speed up system development, reduce costs and bring vehicles to market faster.  
**Sauer-Danfoss – Your Strongest Partner in Mobile Hydraulics.**

**Go to [www.sauer-danfoss.com](http://www.sauer-danfoss.com) for further product information.**

Wherever off-highway vehicles are at work, so is Sauer-Danfoss.

We offer expert worldwide support for our customers, ensuring the best possible solutions for outstanding performance. And with an extensive network of Global Service Partners, we also provide comprehensive global service for all of our components.

Please contact the Sauer-Danfoss representative nearest you.

Local address:

Sauer-Danfoss (US) Company  
2800 East 13th Street  
Ames, IA 50010, USA  
Phone: +1 515 239 6000  
Fax: +1 515 239 6618

Sauer-Danfoss ApS  
DK-6430 Nordborg, Denmark  
Phone: +45 7488 4444  
Fax: +45 7488 4400

Sauer-Danfoss GmbH & Co. OHG  
Postfach 2460, D-24531 Neumünster  
Krokanz 35, D-24539 Neumünster, Germany  
Phone: +49 4321 871 0  
Fax: +49 4321 871 122

Sauer-Danfoss-Daikin LTD.  
Shin-Osaka TERASAKI 3rd Bldg. 6F  
1-5-28 Nishimiyahara, Yodogawa-ku  
Osaka 532-0004, Japan  
Phone: +81 6 6395 6066  
Fax: +81 6 6395 8585

[www.sauer-danfoss.com](http://www.sauer-danfoss.com)