



Directional spool valve type WH16 hydraulically operated

**WK
499 501**

NS16

up to 35 MPa

up to 240 dm³/min

04.2009

APPLICATION

Directional spool valves type **WH16...** are intended for change in direction of fluid flow in a hydraulic system and thus it allows to change direction of movement of a receiver - mostly piston rod of a cylinder or hydraulic motor as well to use functions: *on* and *off*. These directional spool valves are used for subplate mounting in any position in a hydraulic system.



DESCRIPTION OF OPERATION

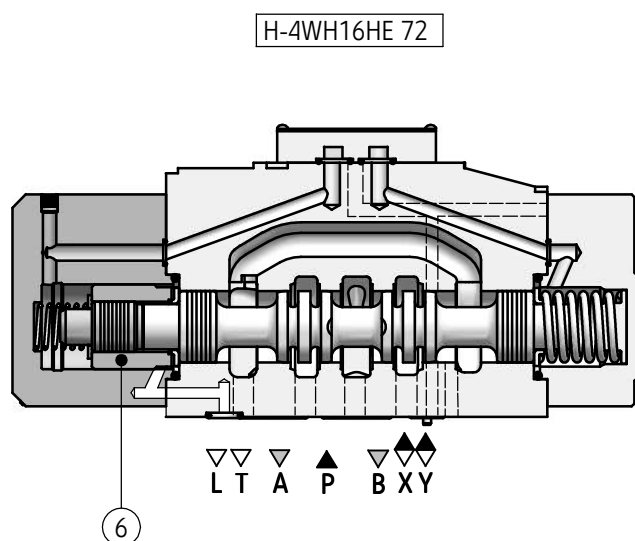
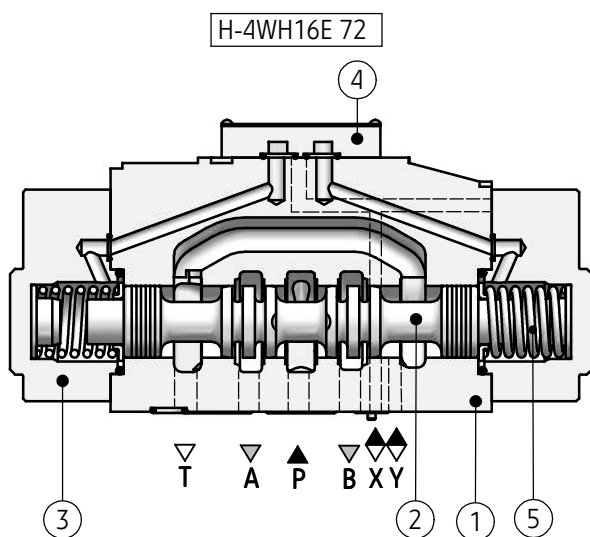

Main bore and annular ports **P, T, A, B** are made in the housing (1) and connected to its subplate connection. Directional valve is switched by shifting the spool (2) into one end position. Various control functions are dependent on the spool (2) which affects the configuration of connections among ports **P, T, A, B** in the housing (1).

The spool (2) is shifted from its neutral position by affecting pressure of hydraulic fluid supplied to one chamber of caps (3). The chambers are connected to control ports by means of cap (4) – adequately one

chamber with port **X** and the other chamber – with port **Y**. The spool (2) is centered in neutral position by means of springs (5) – versions WH16.../... or hydraulically by means of fluid pressure affecting both spool surfaces (2) – versions WH16H.../... - the centering for 3-position spools is secured by the sleeve (6).

Sealing of the directional valve to a subplate is secured by sealing rings.

DESCRIPTION OF OPERATION

...WH16E 72/...S...

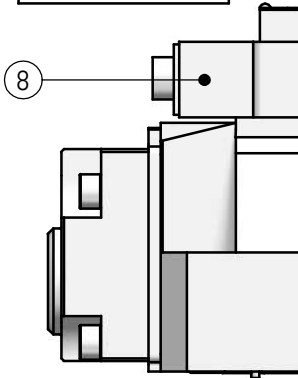

...WH16E 72/...11...

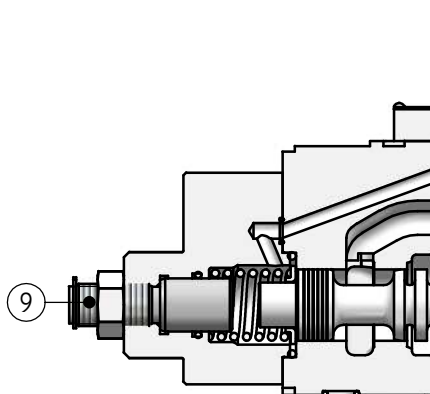

...WH16E 72/...ICZ2m...

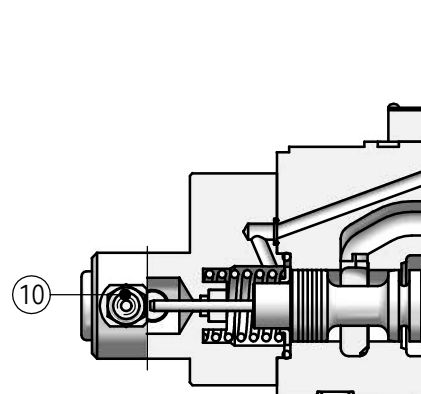

Directional spool valves may be provided with the pilot choke adjustment (8), stroke limiter of the spool (9), end position monitor of the spool (10).

Accessories may be mounted depending version of directional spool valve like given on pages 3, 4, 8, 9.

TECHNICAL DATA

Hydraulic fluid	
Hydraulic fluid	mineral oil
Required filtration	up to 16 µm
Recommended filtration	up to 10 µm
Nominal fluid viscosity	37 mm ² /s at temperature 55 °C
Viscosity range	2,8 up to 380 mm ² /s
Fluid temperature range (in a tank)	recommended 40 °C up to 55 °C
Ambient temperature range	max -20 °C up to +70 °C
Max operating pressure	
ports P, A, B:	
• version H-4 WH 16.../...	35 MPa
• version 4 WH 16.../...	28 MPa
port T	25 MPa
Max control pressure	25 MPa
Min control pressure	
• 3-position directional valve	0,8 MPa
• 2-position directional valve spring centered	1,0 MPa
• 2-position directional valve hydraulically centered	0,5 MPa
Inductive spool position sensor	
Type of sensor (upon order another type available)	ICZD2CNPNA02m
Supply voltage	6 - 30V DC
Max load current	200 mA
Fluid capacity	
<u>3-position directional valve spring centered</u>	5,75 cm ³
<u>3-position directional valve hydraulically centered</u>	
• from 0 (neutral) to operated position a	2,85 cm ³
• from 0 (neutral) to operated position b	5,75 cm ³
• from operated position a to 0 (neutral) position	2,9 cm ³
• from operated position b to 0 (neutral) position	2,3 cm ³
2-position directional spool valve	11,5 cm ³

ACCESSORIES FOR STANDARD DIRECTIONAL VALVE

Pilot choke adjustment

versions: ...4WH16...72 S...
...4WH16...72/S2...

Directional spool valves type **WH16...** may be optionally provided with pilot choke adjustment (throttle check valve type **Z2FS6...** according to data sheet **WK 450 232**) which allows to adjust switching time of directional valve.

The change of adjustment method of switching time (flow throttling):

- on inlet - version ...WH16...72/S...
- on outlet - version ...WH16...72/S2...

is made while mounting by rotating the pilot choke adjustment (1) by 180 degrees around its longitudinal axis.

Rotation of the adjusting screw (3) to the right increases and to the left decreases switching time of the valve.

The pilot choke adjustment is fixed by means of bolts (3) **M5 x 40 - 10.9** - 4 pcs/kit in accordance with **PN - EN ISO 4762** with tightening torque of **Md = 5 Nm**.

...4WH16...72/S...

...4WH16...72/S2...

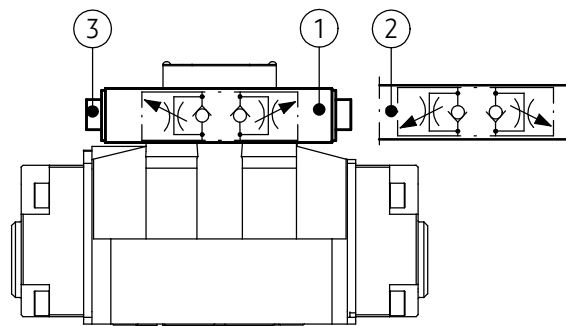

- | |
|---|
| 1 - Pilot choke adjustment with adjustment of switching time on inlet |
| 2 - Assembly method of pilot choke adjustment with adjustment of switching time on outlet |
| 3 - Adjusting screw |

OPTIONAL ACCESSORIES FOR DIRECTIONAL VALVE

Stroke limiter

Stroke limiter of the spool may be mounted:

- stroke limiter on valve ends **A** and **B**
version ...4WH16...72/...10...
- stroke limiter on valve end **A**
version ...4WH16...72/...11...
- stroke limiter on valve end **B**
version ...4WH16...72/...12...

Adjustment of the stroke of the spool is by rotating the pin (3) and securing with locknut (4). Rotating the pin (3) to the right reduces the stroke of the spool. While adjusting the stroke the control chamber must be at zero pressure.

...4WH16...72/...12...

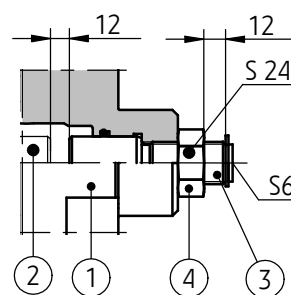

- | |
|---|
| 1 - Stroke limiter body (valve end B) |
| 2 - Spool of main directional spool valve |
| 3 - Pin |
| 4 - Locknut |

OPTIONAL ACCESSORIES FOR DIRECTIONAL VALVE

End position monitoring

End position monitoring may be mounted:

- on valve end **A** }
- on valve end **B** } version ...4WH16...72/... ICZ2m...

Directional valves type **WH16...**- only for 3-position directional valves may be equipped with inductive spool position sensors type **ICZD2CNPNA02m**. Depending on the version, it may be mounted on valve ends **A** or **B**.

Other sensor types may be mounted upon order and if agreed with the manufacturer.

...4WH16...72/...ICZ2m...

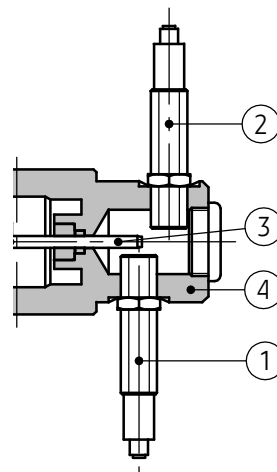

- 1, 2 - Inductive proximity spool sensor **normally open** with the cable of 2 m length type **ICZD2CNPNA02m**
 3 - Pin of the spool
 4 - Cover of the directional valve (on valve end **B**)

Scheme for electrical connection of inductive proximity sensor type ICZD2CNPNA02m

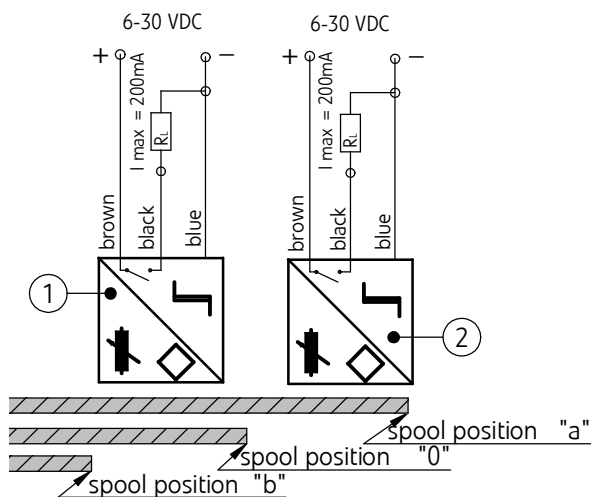

sensor signal	spool position		
	<i>a</i>	<i>0</i>	<i>b</i>
sensor - item ①	1	1	0
sensor - item ②	1	0	0

SCHEMES

Graphic symbols of 3- position directional spool valves

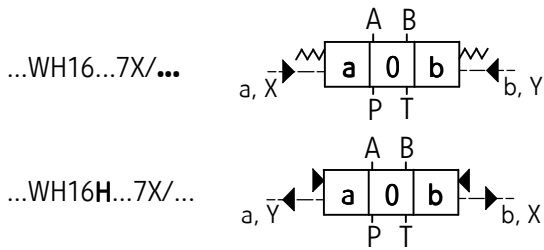

Graphic symbols of 2- position directional spool valves

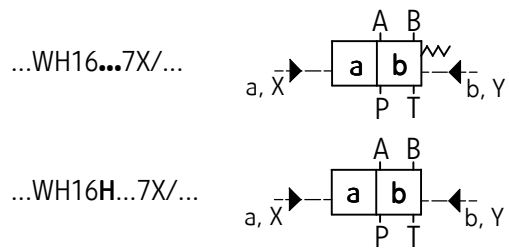

Graphic symbols for spools

working and indirect positions

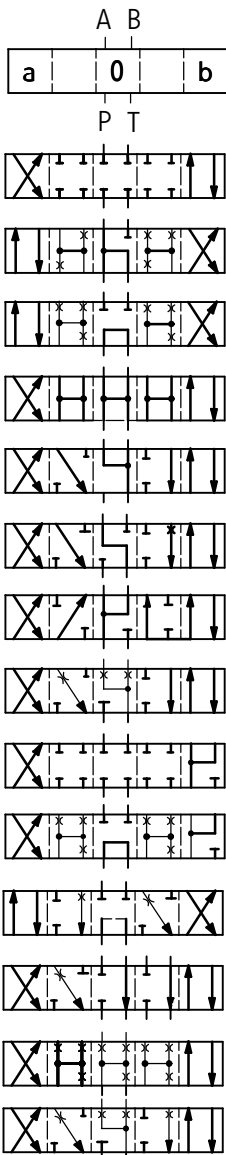

working positions

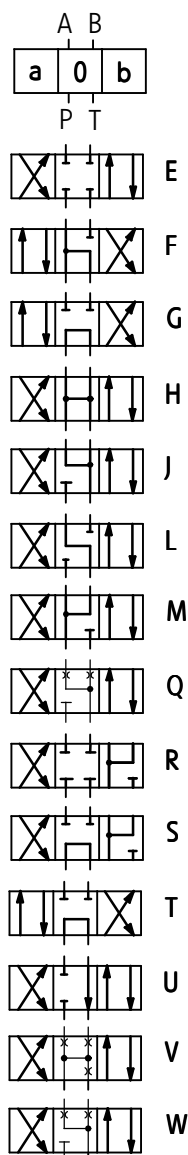

working and indirect positions

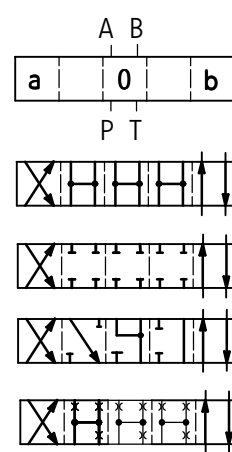

working positions

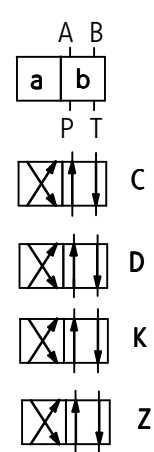

OVERALL AND CONNECTION DIMENSIONS

Standard 3-position versions ...4WH16...7X/...

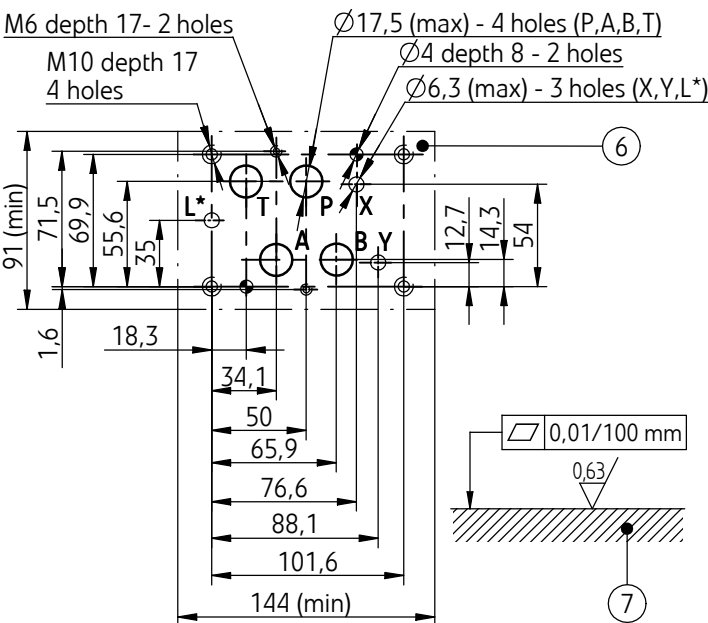
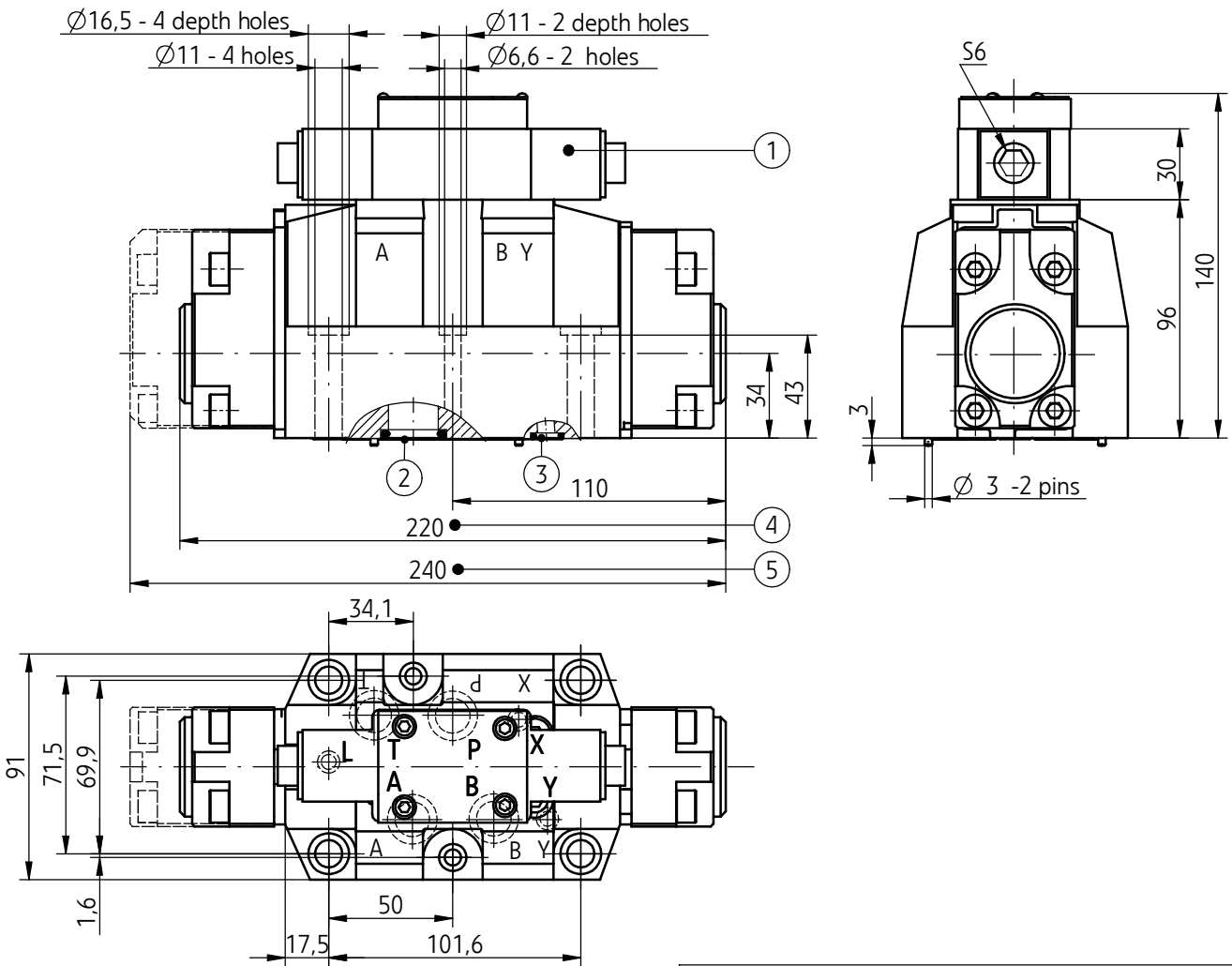

- 1 - Pilot choke adjustment (optional accessories)
 - 2 - Sealing ring **o-ring 22,3 x 2,4** - 4 pcs/kit (P,T,A,B)
 - 3 - Sealing ring **o-ring 10 x 2** - 3 pcs/kit (X,Y,L)
 - 4 - Overall dimension of **3-position directional spool valve spring centered** (spool schemes: E, F, G, H, J, L, M, P, Q, R, T, U, V, W - according to page 5)
 - 5 - Overall dimension of **3-position directional spool hydraulically centered** spool schemes: E, F, G, H, J, L, M, P, Q, R, T, U, V, W - according to page 5)
 - 6 - Porting pattern - configuration of surface holes in subplate in accordance with the following standards:
 - CETOP RP 121H - identified by CETOP 4.2-4-07-320 (nominal size CETOP 07)
 - ISO 4401 - identified by ISO 4401-07-06-0-94 mounting bolts in accordance with PN -EN ISO 4762
- M10 x 60 - 10.9** - 4 pcs/kit
tightening torque **Md = 62 Nm**
- M6 x 60 - 10.9** - 2 pcs/kit
tightening torque **Md = 12,5 Nm**
- NOTE:**
(*) - only for 3-position versions with \emptyset (neutral) position of the spool hydraulically centered
- 7 - Subplate surface required

OVERALL AND CONNECTION DIMENSIONS

Standard 2-position versions ..4WH16...7X/...

$\varnothing 16,5$ - 4 depth holes
 $\varnothing 11$ - 4 holes
 $\varnothing 11$ - 2 depth holes
 $\varnothing 6,6$ - 2 holes

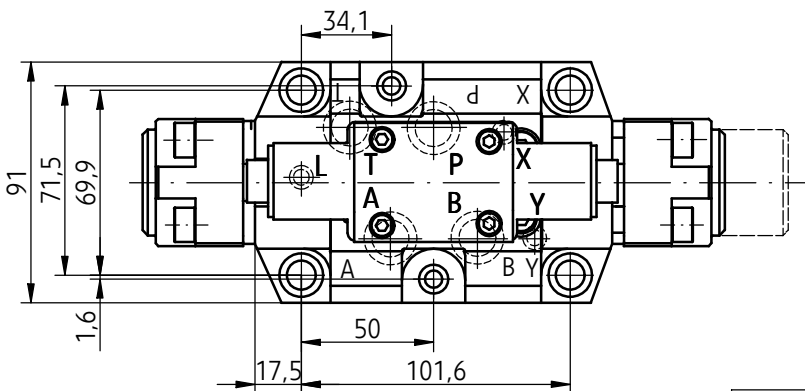
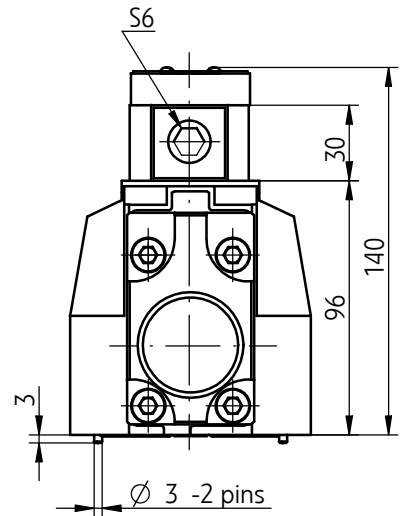
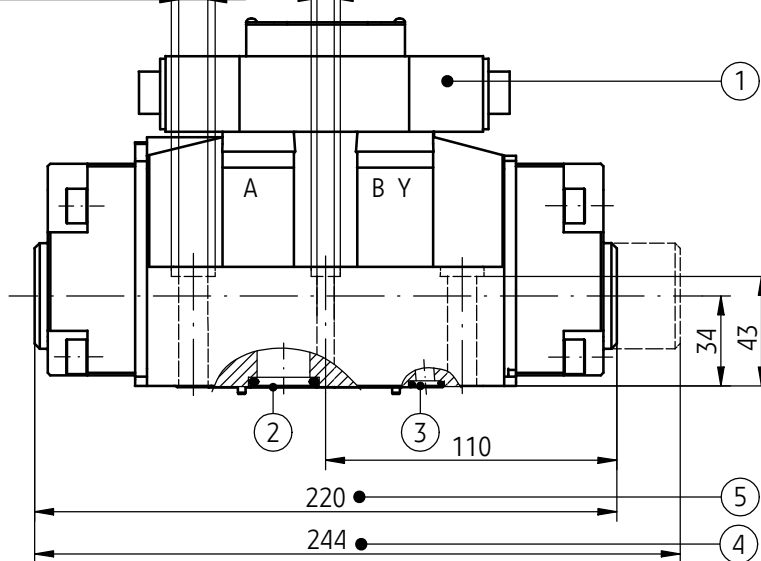

$\varnothing 17,5$ (max) - 4 holes (P,A,B,T)
 $\varnothing 4$ depth 8 - 2 holes
 $\varnothing 6,3$ (max) - 3 holes (X,Y,L*)
 M6 depth 17 - 2 holes
 M10 depth 17 - 4 holes

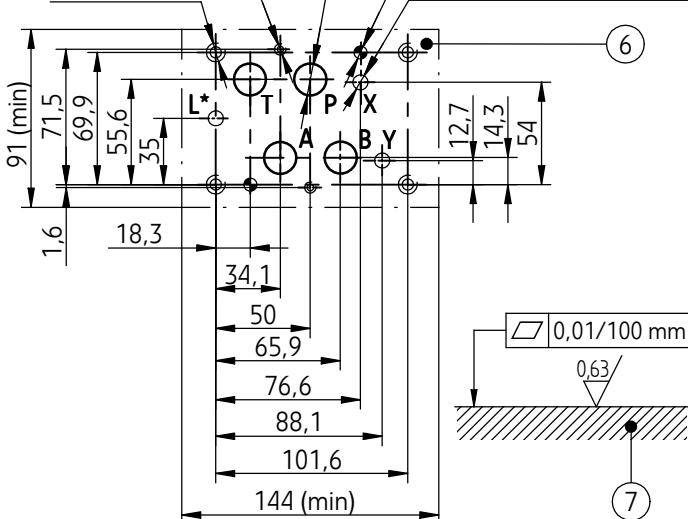

- 1 - Pilot choke adjustment (optional accessories)
- 2 - Sealing ring **o-ring 22,3 x 2,4** - 4 pcs/kit (P,T,A,B)
- 3 - Sealing ring **o-ring 10 x 2** - 3 pcs/kit (X,Y,L)
- 4 - Overall dimension of **2-position directional spool valve spring centered** (spool schemes: C, D, K, Z, according to page 5)
- 5 - Overall dimension of **2-position directional spool hydraulically centered** spool schemes: C, D, K, Z, according to page 5)
- 6 - Porting pattern - configuration of surface holes in subplate in accordance with the following standards:
 - CETOP RP 121H - identified by CETOP 4.2-4-07-320 (nominal size CETOP 07)
 - ISO 4401 - identified by ISO 4401-07-06-0-94 mounting bolts in accordance with PN-EN ISO 4762
- M10 x 60 - 10.9** - 4 pcs/kit
tightening torque **Md = 62 Nm**
- M6 x 60 - 10.9** - 2 pcs/kit
tightening torque **Md = 12,5 Nm**
- NOTE:**
(*) - only for 3-position versions with \emptyset (neutral) position of the spool hydraulically centered
- 7 - Subplate surface required

OVERALL DIMENSIONS OF DIRECTIONAL VALVE WITH OPTIONAL ACCESSORIES

Directional valves with stroke limiter

3-position directional valves with the spool spring centered

Stroke limiter may be mounted:

- on valve end **A** - version ...4WH16...72/...11...
- on valve end **B** - version ...4WH16...72/...12...
- on valve ends **A and B** - version ...4WH16...72/...10...

...4WH16...72/...10...

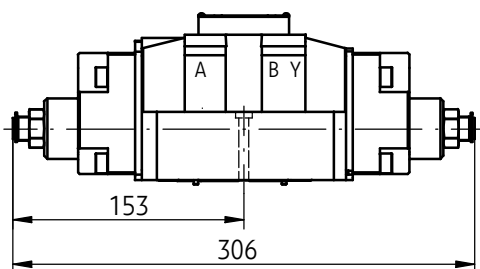

2-position directional valves with the spool hydraulically positioned

Stroke limiter may be mounted:

- on valve end **A** - version ...4WH16H...72/...11...
- on valve end **B** - version ...4WH16H...72/...12...
- on valve end **A i B** - version ...4WH16H...72/...10...

...4WH16H...72/...10...

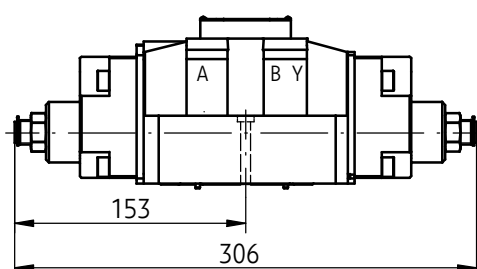

3-position directional valves with the spool hydraulically centered

Stroke limiter may be mounted:

- on valve end **B** - version ...4WH16H...72/...12...

...4WH16H...72/...12...

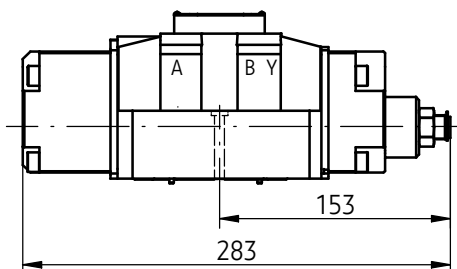

2-position directional valves with the spool spring positioned

Stroke limiter may be mounted:

- on valve end **A** - version ...4WH16...72/...11...

...4WH16...72/...11...

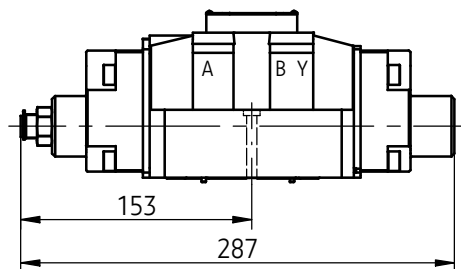

OVERALL DIMENSIONS OF DIRECTIONAL VALVE WITH OPTIONAL ACCESSORIES

Directional valves with end position monitoring

3-position directional valves with the spool spring centered

End position monitoring may be mounted:

- on valve end A } version ...4WH16...72/... ICZ2m...
- on valve end B }

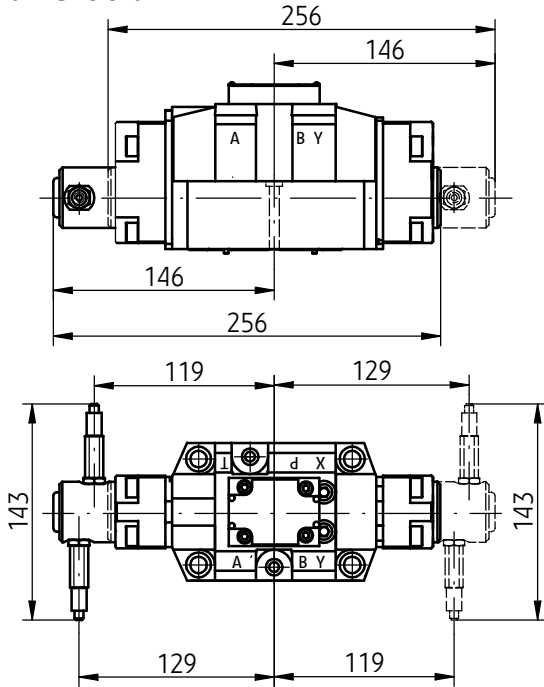

...4WH16...72/...ICZ2m...

3-position directional valves with the spool hydraulically centered

End position monitoring may be mounted:

- on valve end B - version ...4WH16H...72/...ICZ2m...

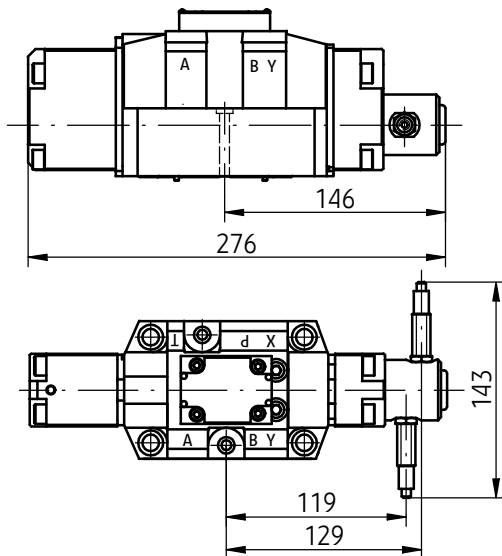

...4WH16H...72/... ICZ2m...

Directional valves with stroke limiter and end position monitoring

3-position versions with the spool spring centered

Stroke limiter and end position monitoring may be mounted:

- stroke limiter on valve end A and end position monitoring on valve end B - version ...4WH16...72/... 11 ICZ2m...
- stroke limiter on valve end B and end position monitoring on valve end A - version ...4WH16...72/...12 ICZ2m...

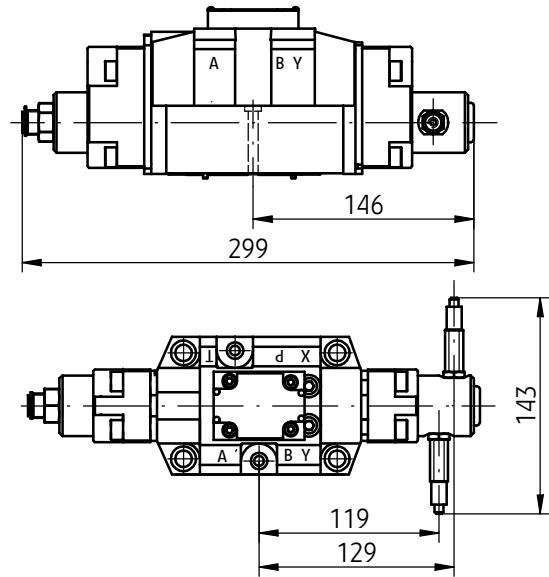

...4WH16...72/...11 ICZ2m...

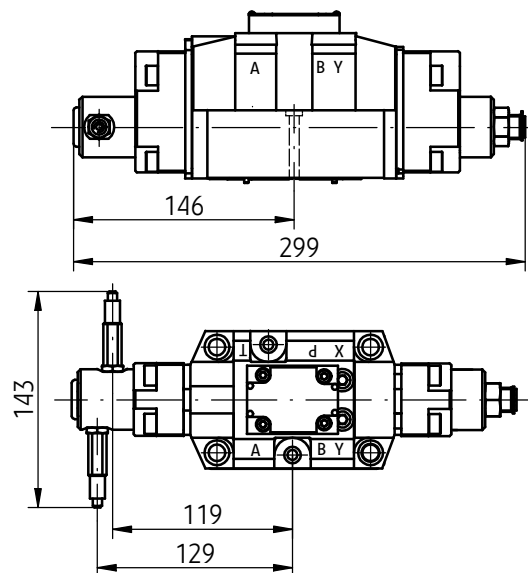

...4WH16...72/...12 ICZ2m...

PERFORMANCE CURVES

measured at viscosity $\nu = 41 \text{ mm}^2/\text{s}$ and temperature $t = 50^\circ\text{C}$

Flow resistance curves

Flow curves $\Delta p(Q)$ for directional valves type ...WH16... with spools **E** and **R**

- 1 - spools: **E, R**
- 2 - spool **R**- flow direction **P→A** and **B→A**

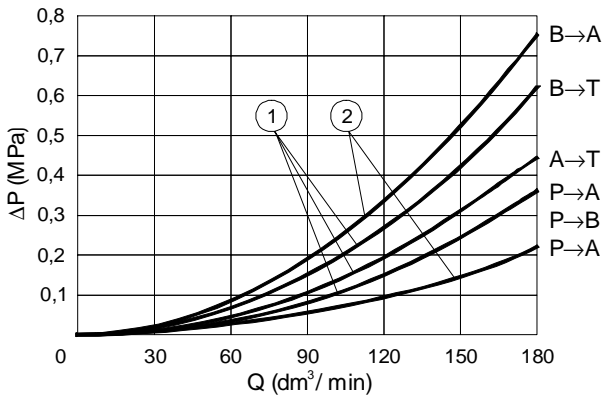

Flow curves $\Delta p(Q)$ for directional valves type WH16... with spools: **F, H, J, L, M, Q, S, U, V, W, C, D, K, Z**

- 1 - spool **S**
- 2 - spools: **F, H, J, L, M, Q, U, V, W, C, D, K, Z**

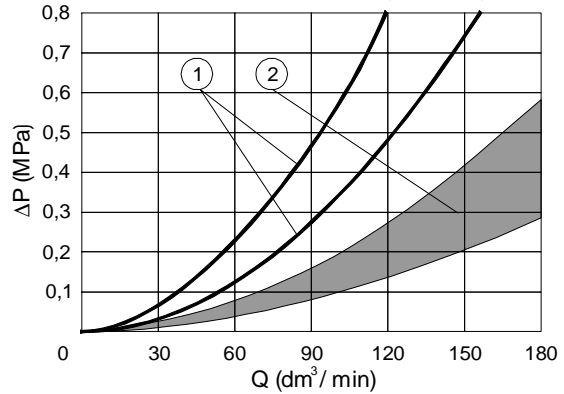

Flow curves $\Delta p(Q)$ for directional valves type ...WH16... with spools **G** and **T**

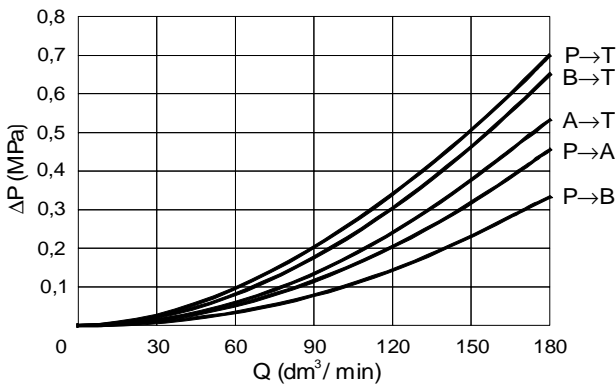

Flow limits

Characteristic curves **p - Q** for directional valves type ...WH16... for 2-positions and 3-position directional valves spring centered with various spools

spool type	pressure p [MPa]				
	7	14	21	28	35
flow Q [dm ³ /min]					
E, J, L, M, Q, R, U, V, W, C, D, K, Z	240	240	205	180	170
F	200	145	115	100	90
G, H, S, T	220	160	130	110	100

NOTES:

Above flow limits are related to standard application of 4-way directional spool valve i.e. using two flow directions: **P** to **A** and at the same time **B** to **T**. In case 4-way directional spool valve with only one flow direction – **P** to **A** (**B** plugged) or **A** to **T** (**B** plugged) is applied then actual flow limit rates are significantly lower.

HOW TO ORDER

H	4	WH	16				/	+				*
----------	----------	-----------	-----------	--	--	--	---	---	--	--	--	---

Version
 normal pressure
up to 28 MPa = no designation
 high pressure
up to 35 MPa = H

Number of service ports
4-way = 4

Nominal size (NS)
NS16 = 16

Centering/ spool positioning
spring centering = no designation
 hydraulic off-set = H

Spool type
spool schemes - according to **page5**

Series number
 (70-79) - installation and connection dimensions unchanged = 7X
series 72 = 72

Switching time adjustment
without switching time adjustment = no designation
 switching time adjustment as meter-in control = S
 switching time adjustment as meter-out control = S2

Accessories
without accessories = no designation
 stroke limiter on valve ends **A** and **B** = 10
 stroke limiter on valve end **A** = 11
 stroke limiter on valve end **B** = 12

End position monitoring
 (applicable only to 3-position valves, end position monitoring mounted on valve end **A** or **B** according to page 9 - to be agreed with the manufacturer)
 inductive spool position sensor with the cable of 2 m length = ICZ 2m
 another type of sensor (to be agreed with the manufacturer) = to be specified

Sealing
NBR (for fluids on mineral oil base) = no designation
FPM (for fluids on phosphate ester base) = V

Further requirements in clear text (to be agreed with the manufacturer)

NOTES:

The directional spool valve should be ordered according to the above coding.

The symbols in bold are preferred versions in short delivery time.

Coding example: H-4WH16 E 72/ S2 - ICZ2m

EXAMPLE OF APPLICATION IN HYDRAULIC SYSTEM

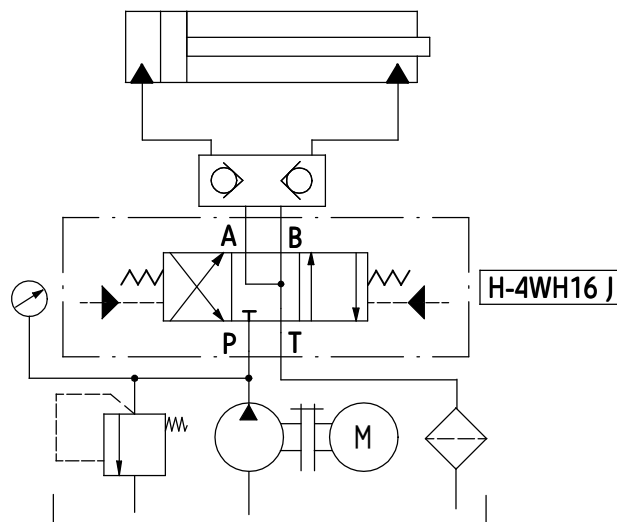

SUBPLATES AND MOUNTING BOLTS

Subplates for directional spool valve type **WH16...** must be ordered according to data sheet **WK 450 788**.

Subplate types:

- G174/01** - threaded connections P, T, A, B - G 1
X, Y, L - G1/4
- G174/02** - threaded connections P, T, A, B - M33 x 2
X, Y, L - M14 x 1,5
- G172/01** - threaded connections P, T, A, B - G3/4
X, Y, L - G1/4
- G172/02** - threaded connections P, T, A, B - M27 x 2
X, Y, L - M14 x 1,5

Subplates and bolts for mounting directional valve: in accordance with **PN - EN ISO 4762**:

- M10 x 60 -10,9** - 4 pcs/kit
 - M 6 x 60 -10.9** - 2 pcs/kit
must be ordered separately.
- Tightening torques for bolts:
- M10 x 60** - **Md = 62 Nm**
 - M 6 x 60** - **Md = 12,5 Nm**

PONAR Wadowice S.A.
ul. Wojska Polskiego 29
34-100 Wadowice
tel. +48 33 488 29 00
fax. +48 33 488 21 03
www.ponar-wadowice.pl

