

RE 29 218/12.02

Replaces: 11.98

**3/2-way high response control valve
(cartridge valve)
Type 3FERE,
with integrated control electronics**

Nominal sizes 25, 32 and 50

Series 3X

Maximum operating pressure 315 bar

Maximum flow 1800 L/min

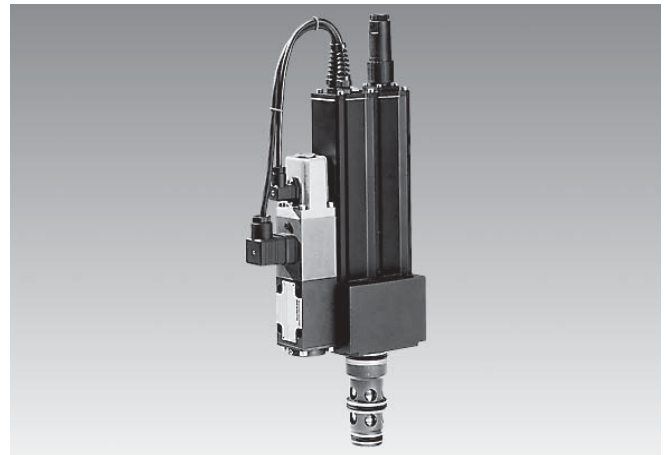

H/A 4539/94

Type 3FERE 25 C-3X/... with plug-in connector (separate order)

Overview of contents

Contents	Page
Features	1
Ordering details	2
Preferred types	2
Symbols	2
Design and function, section	3
Technical data	4
Electrical connections	5
Block circuit diagram / connection allocation of the integrated control electronics	6
• Voltage input	
• Current input	
Function of the control electronics	7
Characteristic curves	8 to 13
• Flow-command value function	
• Pressure-command value function	
• Frequency response	
Unit dimensions	14
Installation dimensions	15

Features

- Pilot operated 3/2-way high response control valve
- Cartridge valve
- Porting pattern similar to DIN 24 342 Form A (see page 15)
- Control of the amount and direction of a flow
- May be used for the closed loop control of pressure, speed and position
- Completely matched unit with integrated digital control electronics
- Optionally available with voltage or current interface for command and actual values
- In case of a fault, the connection from P to A is blocked and from A to T is automatically opened



© 2003
by Bosch Rexroth AG, Industrial Hydraulics, D-97813 Lohr am Main

All rights reserved. No part of this document may be reproduced or stored, processed, duplicated or circulated using electronic systems, in any form or by means, without the prior written authorisation of Bosch Rexroth AG. In the event of contravention of the above provisions, the contravening party is obliged to pay compensation.

Ordering details

3FERE		C -3X/		A1	A	M		*
Nominal size 25	= 25							Further details in clear text
Nominal size 32	= 32							
Nominal size 50	= 50							
Cartridge valve	= C							M = NBR seals, suitable for mineral oil (HL, HLP to DIN 51 524)
Series 30 to 39 (30 to 39: unchanged installation and connection dimensions)	= 3X							Electrical connections
Nominal flow, For NS 25	240 L/min	= 240						K31 = Without plug-in connector, with component plug to E DIN 43 563-AM6-3
max. at For NS 32	450 L/min	= 450						Plug-in connector - separate order, see page 5
$\Delta p = 10$ bar: For NS 50	800 L/min	= 800						V10 = Com. value input/act. value output $\pm 10V$
Linear fine control range when starting to open	= A1							A20 = Com. value input/act. value output 4 to 20 mA
A = Control land overlap at main spool in % of the stroke: - 1 to + 0.3								

Preferred types (readily available)

Material No.	Type
R900947583	3FERE 25 C-3X/240A1AV10K31M
R900954502	3FERE 32 C-3X/450A1AV10K31M
R900954503	3FERE 50 C-3X/800A1AV10K31M

Symbole

Simplified

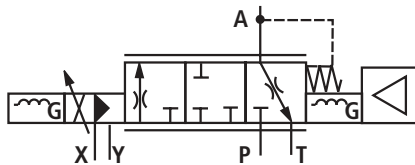

Detailed

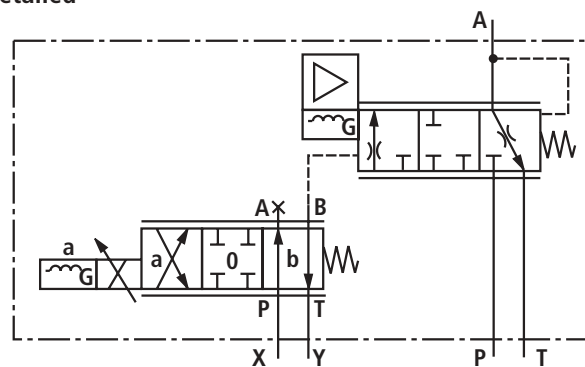

Design and function, section

The 3/2-way high response control valve is designed as a cartridge valve with integrated digital control electronics for the stepless closed loop control of a flow for P to A and A to T.

Technical design

The valve consists of 5 main component groups

- Cover (1) with mounting surfaces,
- Main spool (7) with eroded control edges,
- Sleeve (2),
- Integrated control electronics (4) with inductive position transducer (12) for the main spool,
- Pilot control valve (3) with a paired spool-sleeved unit (5) and inductive position transducer (6).

Function

- Control of the main spool (7) via the pilot control valve (3); pressure build-up in the control chamber (10) acts on area (8) – against this, acts the pressure of port A on area (13) and the spring force (9).
- Control of spool (5) of the pilot control valve via the proportional solenoid (14) against the force of the spring (11).
- Linking of command values and actual values (12, 6) in the micro-controller of the integrated control electronics (4).
- Pilot oil supply X to the pilot control valve from port P or external supply; pilot oil drain via Y to tank.
- With a command value of 0 V or 12 mA the closed loop electronics moves the main spool (7) into its centre position, thus pressure in A ~ P/2.
- Area ratio from area (13) to area (8) for:
 - Nominal size 25 1 : 1.56
 - Nominal size 32 1 : 1.54
 - Nominal size 50 1 : 1.08

Supply voltage failure

- The integrated electronics de-energises the solenoid when the supply voltage fails or a cable break occurs.
- Pressure unloading of spool area (8) via pilot control valve (3) to Y to tank.
- Via the spring force (9) and the pressure in port A acting on area (13), the main spool (7) opens the connection from A to T and closes the connection from P to A

 Failure of supply voltage leads to the sudden stand still of the control axis. The occurring accelerations may cause machine damage.

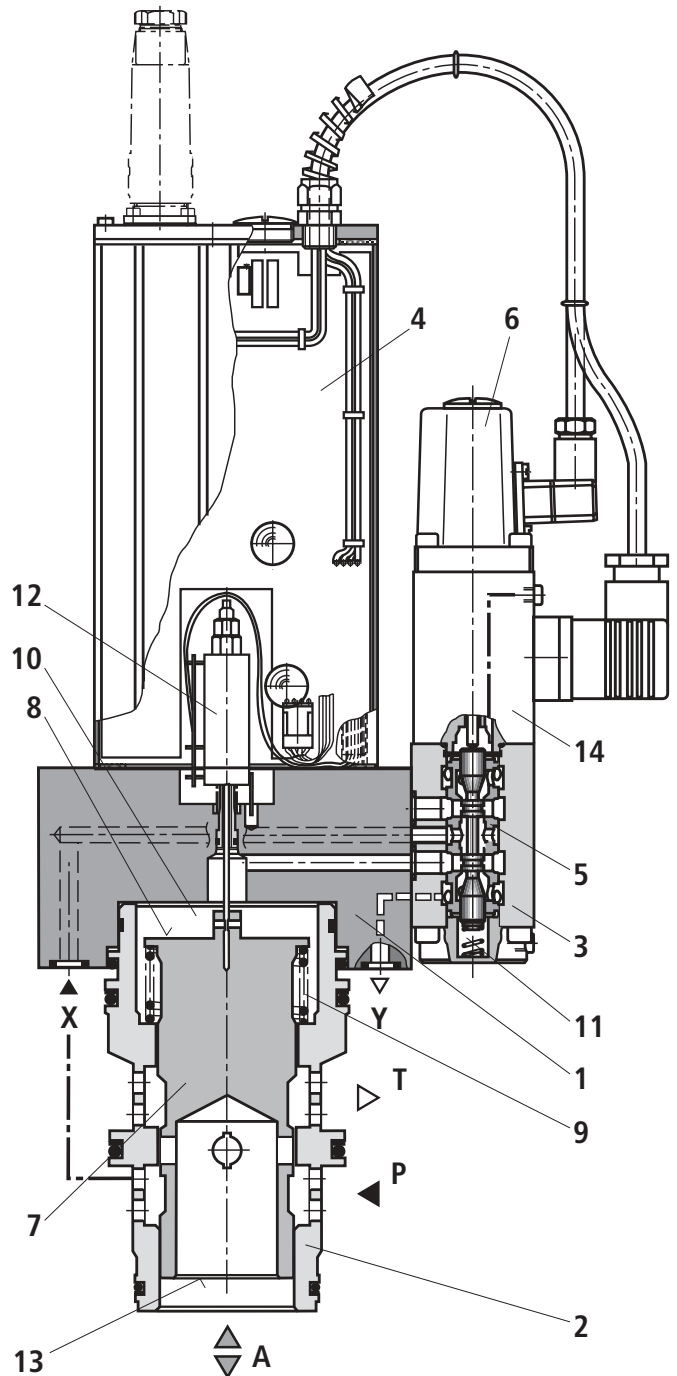

Technical data (for applications outside these parameters, please consult us!)

General

Nominal size		25	32	50
Installation		Optional, (when the valve is mounted onto an actuator it should be avoided that the main spool lies parallel to the acceleration or deceleration direction of the actuator!)		
Storage temperature	°C	- 20 to + 80		
Ambient temperature range	°C	- 20 to + 50		
Weight	kg	7.5	8.2	15.5

Hydraulic (measured with HLP 46, $\vartheta_{oil} = 40 \text{ °C} \pm 5 \text{ °C}$)

Max. operating pressure – Ports A; P; X	bar	Up to 315		
Return pressure – Ports T; Y	bar	Up to 30		
Nominal flow $q_{V \text{ nom}}$ at $\Delta p = 10 \text{ bar}$	L/min	240	450	800
Max. permissible flow	L/min	600	900	1800
Max. zero flow with the spool in its centre position (with $p = 315 \text{ bar}$)	L/min	1.5	2.5	3.5
Control stroke of main spool	mm	± 5	± 7	± 8.5
Control flow at X or Y for min. opening time (command value – 100 % to + 100 %)	L/min	12	16	30
Area ratio at main spool		1 : 1.56	1 : 1.54	1 : 1.08
Main spool spring		$\Delta p = 2.5 \text{ bar}$ (referring to the spool area at port A)		
Pressure fluid		Mineral oil (HL, HLP) to DIN 51 524		
Pressure fluid temperature range	°C	- 20 to + 80		
Viscosity range	mm ² /s	15 to 380		
Cleanliness class to ISO code		Maximum permissible degree of contamination of the pressure fluid is to ISO 4406 (C) class 18/16/13 ¹⁾		
Hysteresis	%	< 0.1		
Response sensitivity	%	< 0.1		

Electrical

Supply voltage	Nominal voltage	VDC	24
	Lower limiting value	VDC	21
	Upper limiting value	VDC	35
Power consumption	I_{max}	A	1.8
	Impulse load	A	3
Duty		%	100
Plug-in connector			To E DIN 43 563–BF6–3/Pg11
Component plug			To E DIN 43 563–AM6–3
Plug-in connector (pilot control valve)			To DIN EN 175 301-803
Plug-in connector (position transducer, pilot control valve)			G4W1F/socket G4A5M
Protection to DIN 40 050			IP 65 with mounted and fixed plug-in connector
Temperature drift of the main spool		%/10 K	0.3
Fault recognition			Valve automatically closes P → A and opens A → T (also see page 7)
Control electronics			VT 13 040 (integrated in the valve; see pages 6 and 7)

¹⁾ The cleanliness class stated the components must be adhered too in hydraulic systems. Effective filtration prevents faults from occurring and at the same time increases the component service life.

For the selection of filters see catalogue sheets RE 50 070, RE 50 076 and RE 50 081



Note: For details regarding the **environmental simulation test** covering EMC (electro-magnetic compatibility), climate and mechanical loading see RE 29 218-U (declaration regarding environmental compatibility).

Electrical connections

Plug-in connector

Plug-in connector to E DIN 43 563-BF6-3/Pg11

Separate order under Material No. **00021267** (plastic version)

For pin allocation see block circuit diagram on page 6

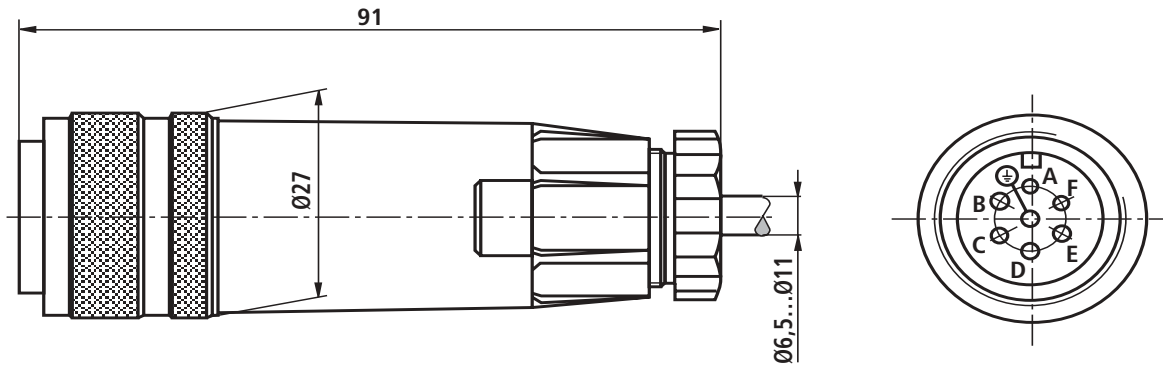

Component plug pin allocation

	Contact	Signal	
Supply voltage	A	24 VDC	
	B	0 V (GND)	
Enable	C	5 to 35 V	
Command value (differential amplifier input)	D	Voltage input ± 10 V	Current input 4 to 20 mA
	E	0 V	
Actual value, main spool	F	± 10 V	4 to 20 mA
	PE		

Recommended connection cables:

- Up to 25 m → min. 0.75 mm² per core
- Up to 50 m → min. 1.5 mm² per core
- With braided screen (connect the screen on one end to the supply zero of the power supply)
- Max. outside diameter 6.5 to 11 mm

Block circuit diagram / connection allocation of the control electronics type VT 13 040 (voltage input)

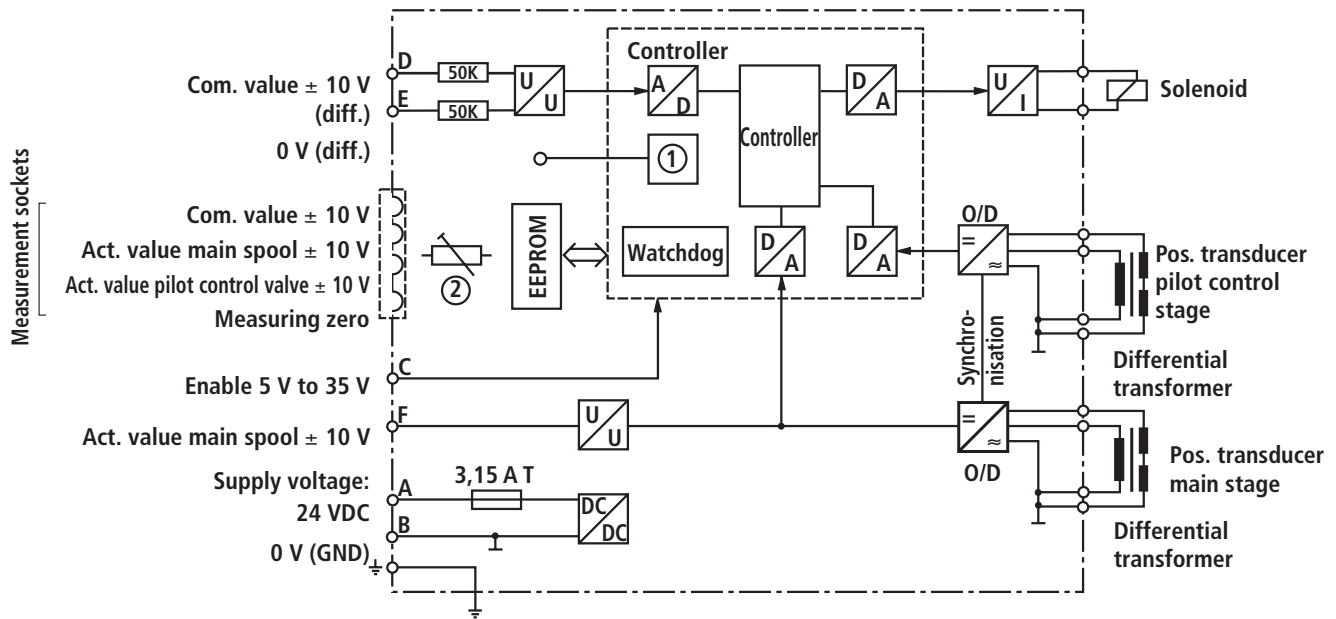

- 1 Interface for test purposes (test point is not externally accessible)
- 2 Zero point adjustment at main stage (see page 14)

Positive command value at port D causes flow from P to A in the main stage.

Block circuit diagram / connection allocation of the control electronics type VT 13 040 (current input)

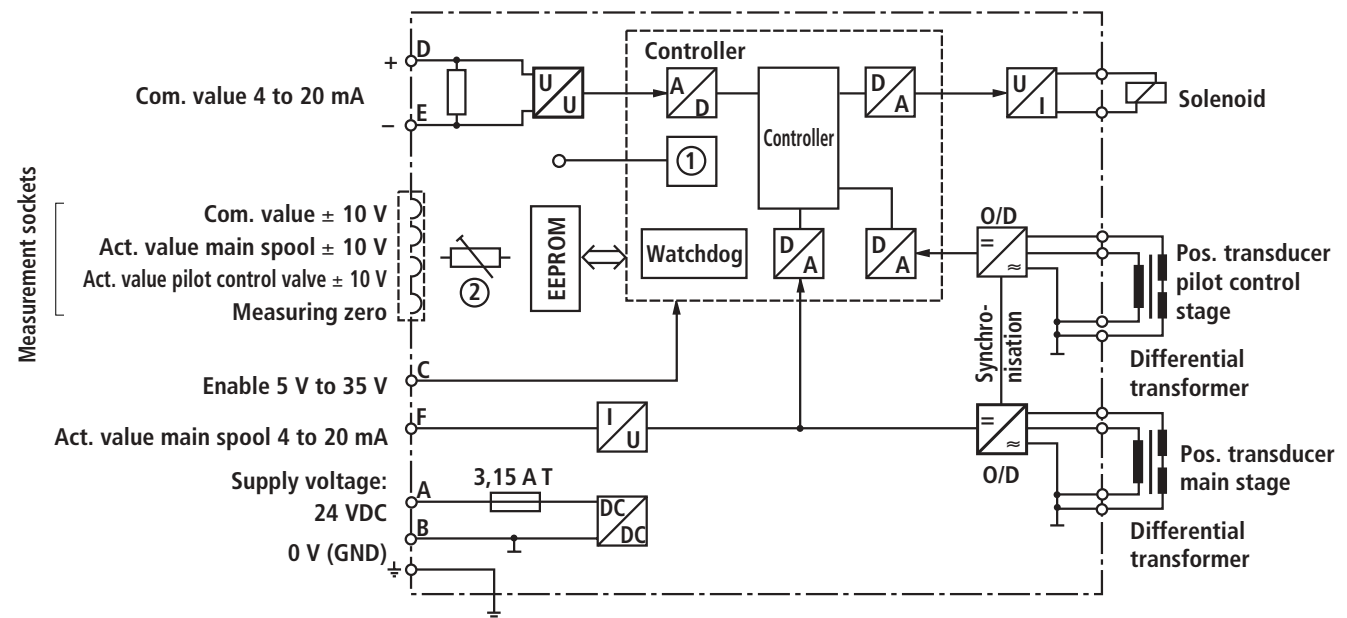

- 1 Interface for test purposes (test point not externally accessible)
- 2 Zero point adjustment main stage (see page 14)

Command value 12 to 20 mA at port D causes flow from P to A in the main stage.

Command value 12 to 4 mA at port D causes flow from A to T in the main stage.

Control electronic functions

- Closed loop control of the position of the pilot control spool and the main spool
- Acquisition of the spool positions via the inductive position transducers
- Linking of the command and actual values via the controller of the micro-controller
- Fault recognition and evaluation via a monitoring unit in the micro-controller.

Valve commissioning / enable of the controller function

1. Apply the supply voltage of 24 VDC
2. Apply a command value 4 - 20 mA or ± 10 V
3. Controller activation via the enable 5 V to 35 V
4. The main spool immediately assumes, with the valve dynamics, the defined command value position.

Switching-off of the controller

Automatic interruption of the current to the solenoid coil after 5 minutes when there is no hydraulic pressure present at the valve.

Fault recognition

- Type "command value ± 10 V" → Recognition of the following errors (no message as collective error):
- Short circuit at the proportional solenoids
 - Ground connection at the proportional solenoids
 - Cable break or short circuit at the transducer of the pilot control or main stage
 - Overload at the position transducer of the pilot control or main stage
 - Supply voltage < 20 V
 - Internal interference of the controller (e. g. Watchdog)
 - Valve electrically controlled, hydraulic system without pressure
- Type "command value 4 to 20 mA" → Recognition of the following errors and messages as a collective error with actual value 0 mA at pin F of the component plug:
- All faults as with type "command value ± 10 V"



With the type 3FERE.../...**V10**... the opening of one or two command value inputs during operation may cause command value disturbances. This results in an uncontrolled valve position and thus to undesired machine movements.

Note: **Electrical signals (e.g. actual value - feedback signals) taken via valve electronics must not be used to switch off the machine safety functions!**
(This is in accordance with the regulations to the European standard "Safety requirements of fluid technology systems and components – hydraulics", EN 982 !)

Characteristic curves (measured with HLP 46, $\vartheta_{oil} = 40 \text{ }^\circ\text{C} \pm 5 \text{ }^\circ\text{C}$)

NS 25

Flow-command value function

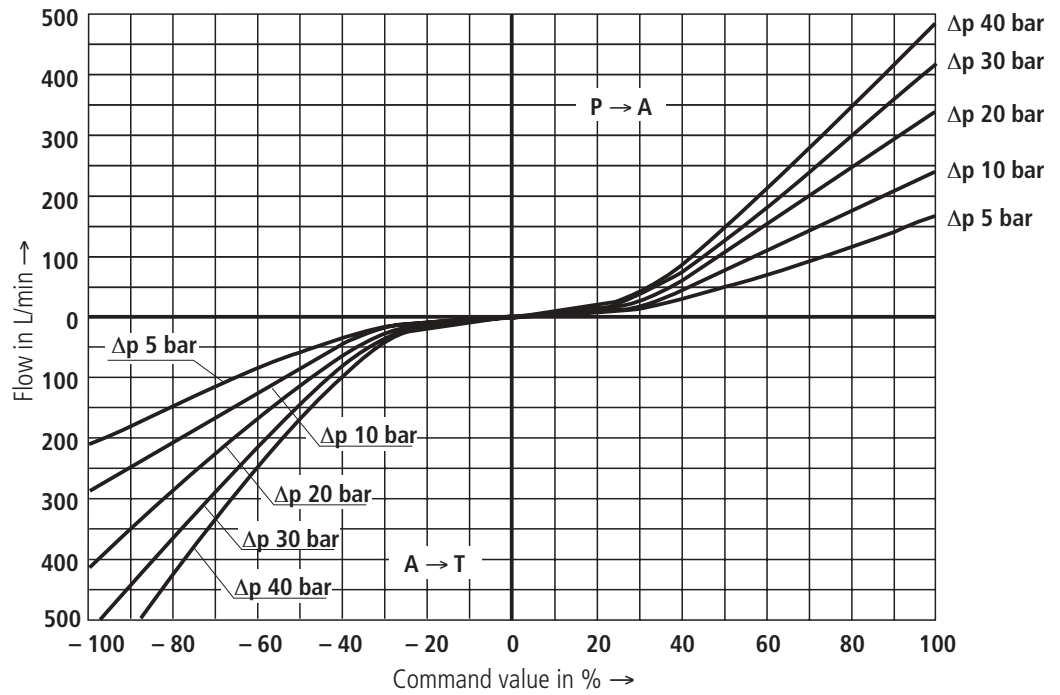

NS 25

Pressure-command value function

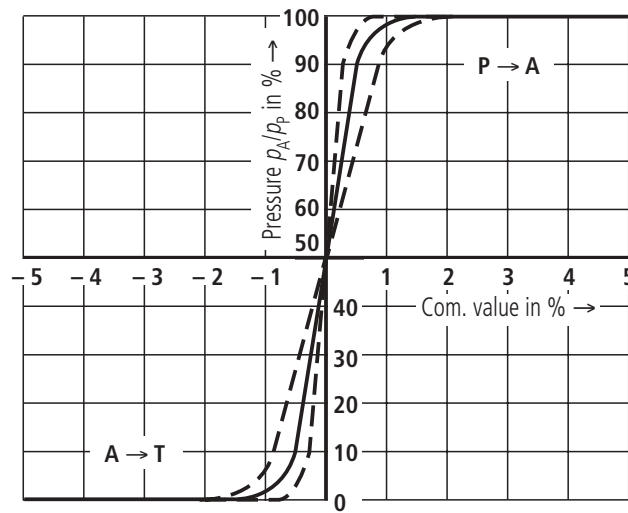

NS 25 Frequency response

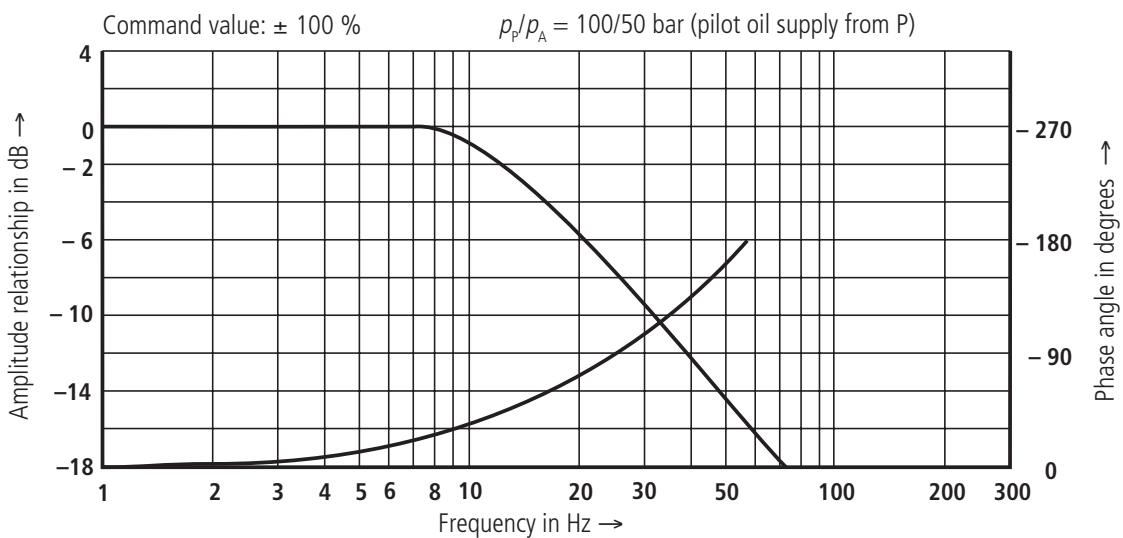
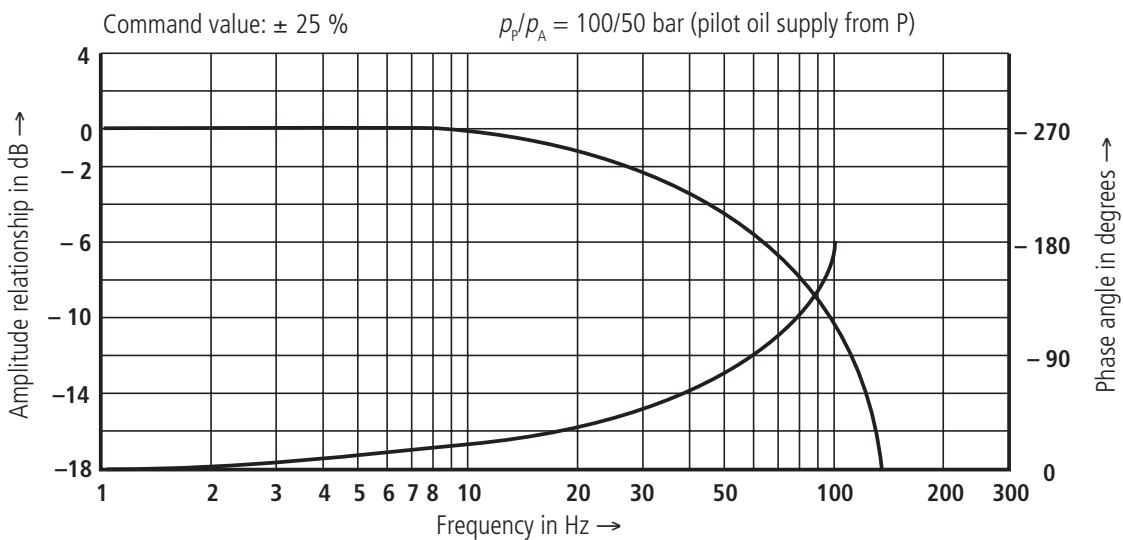
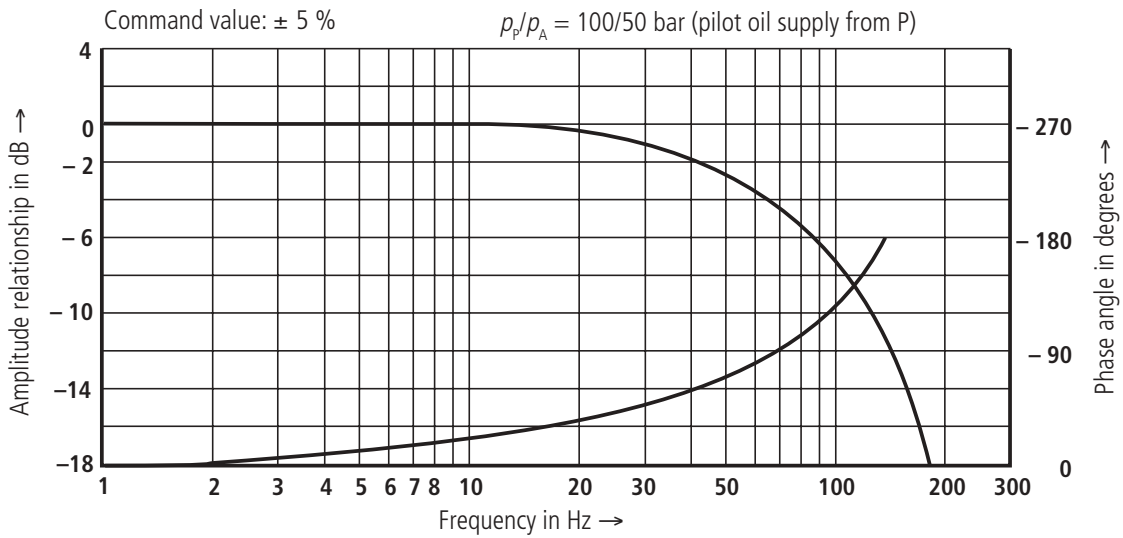

NS 32

Flow-command value function

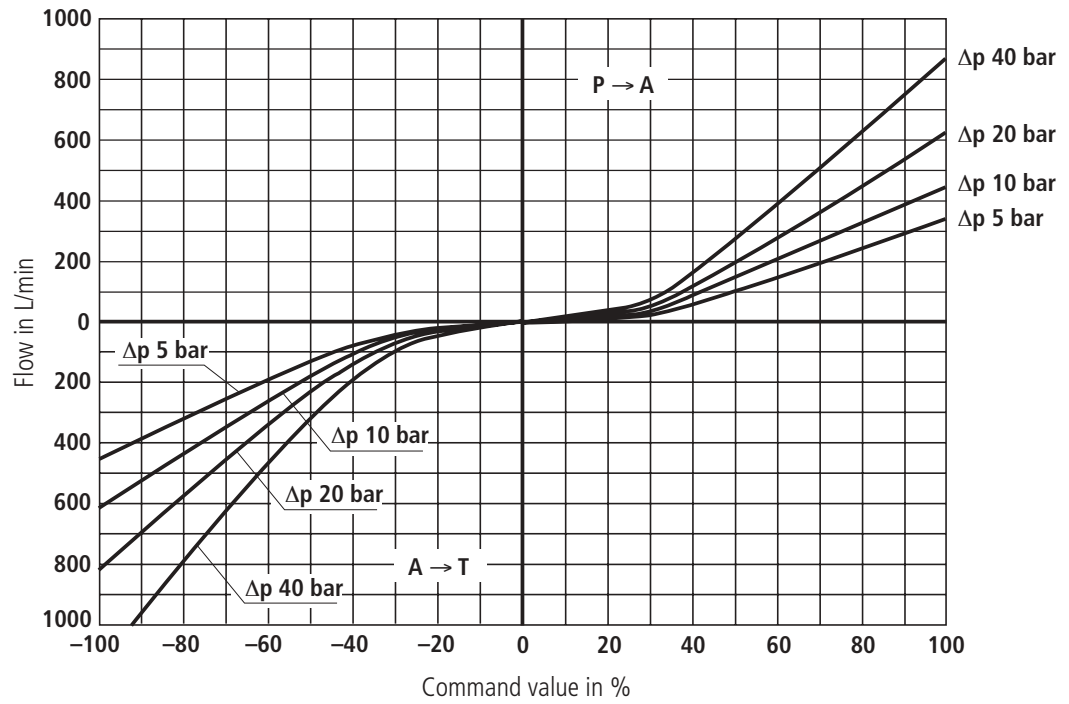

NS 32

Pressure-command value function

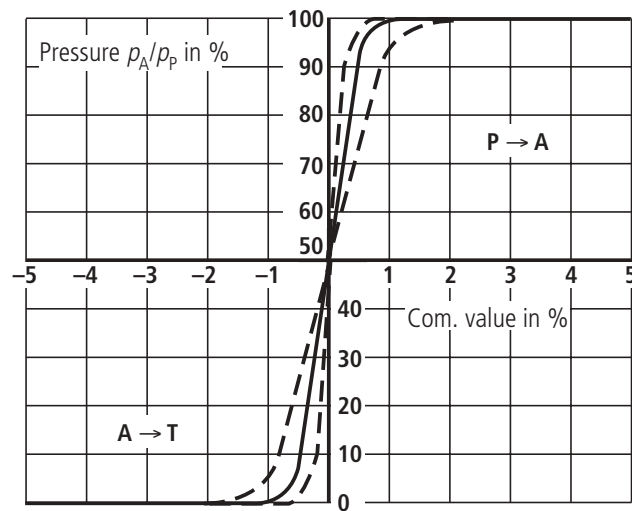

NS 32 Frequency response

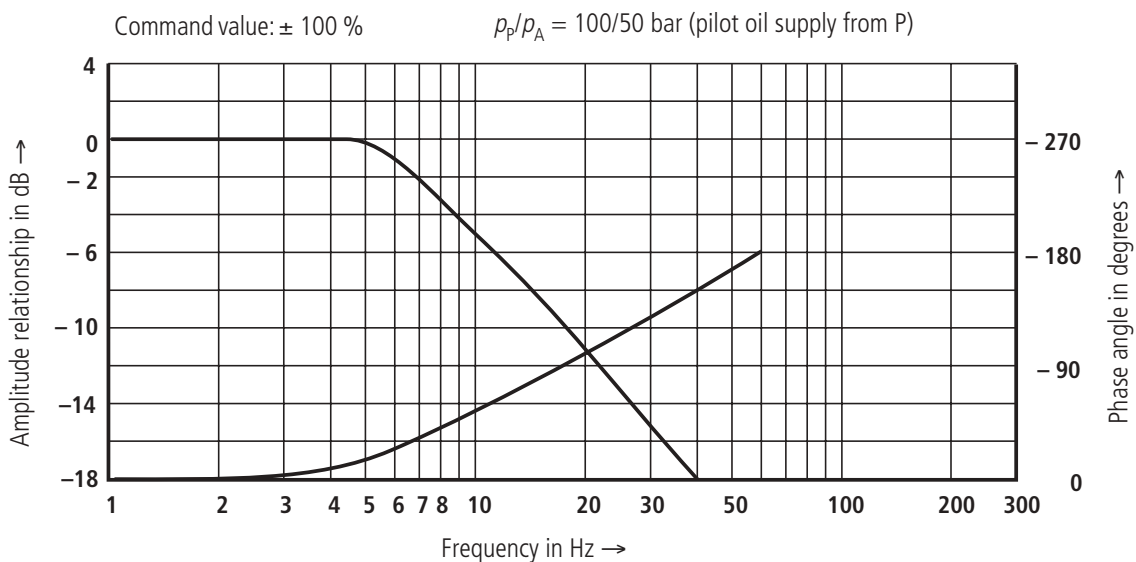
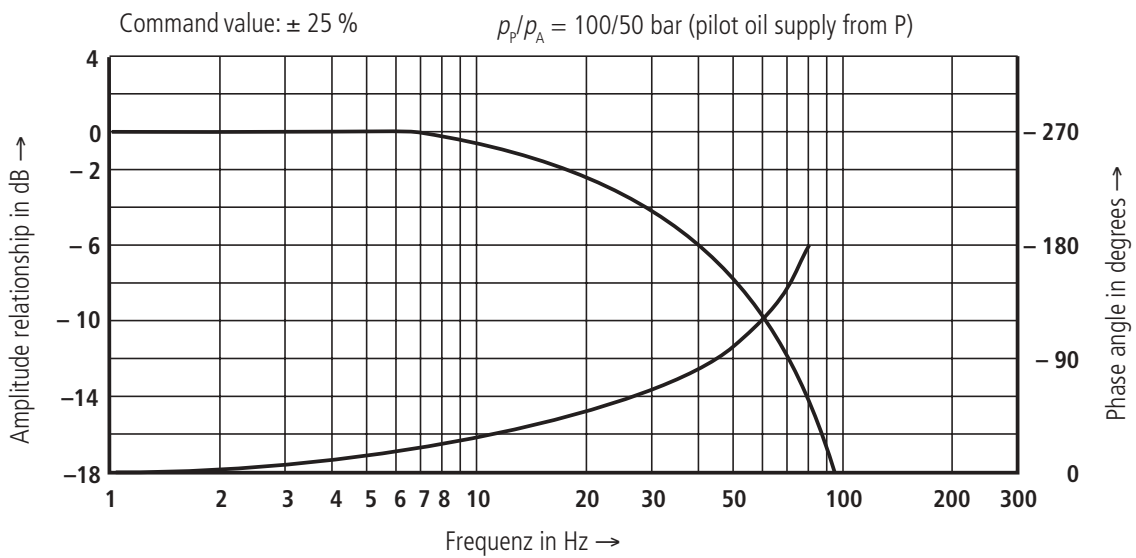
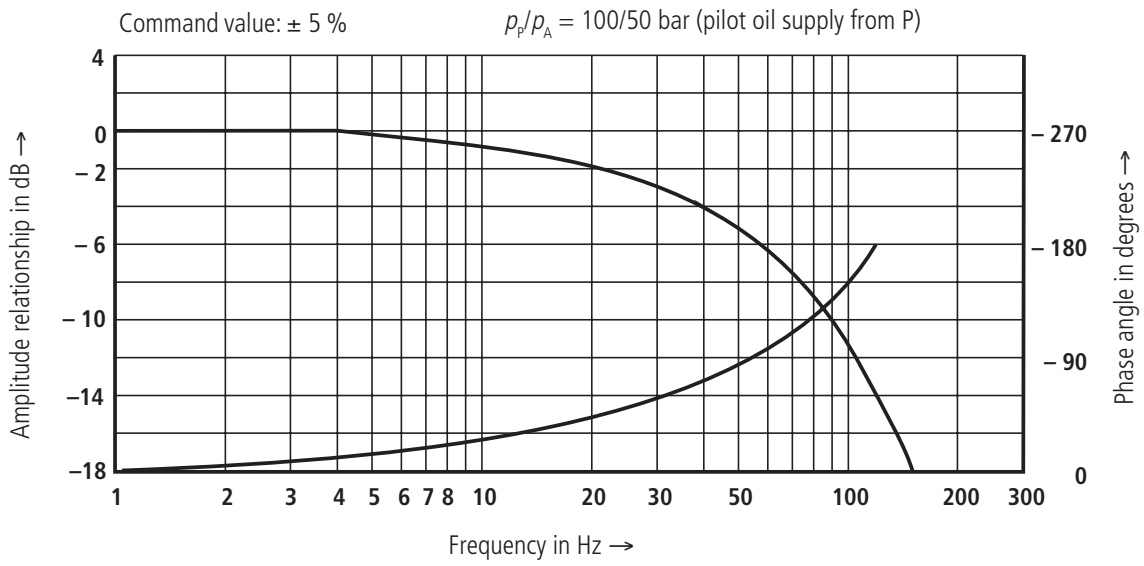

NS 50

Flow-command value function

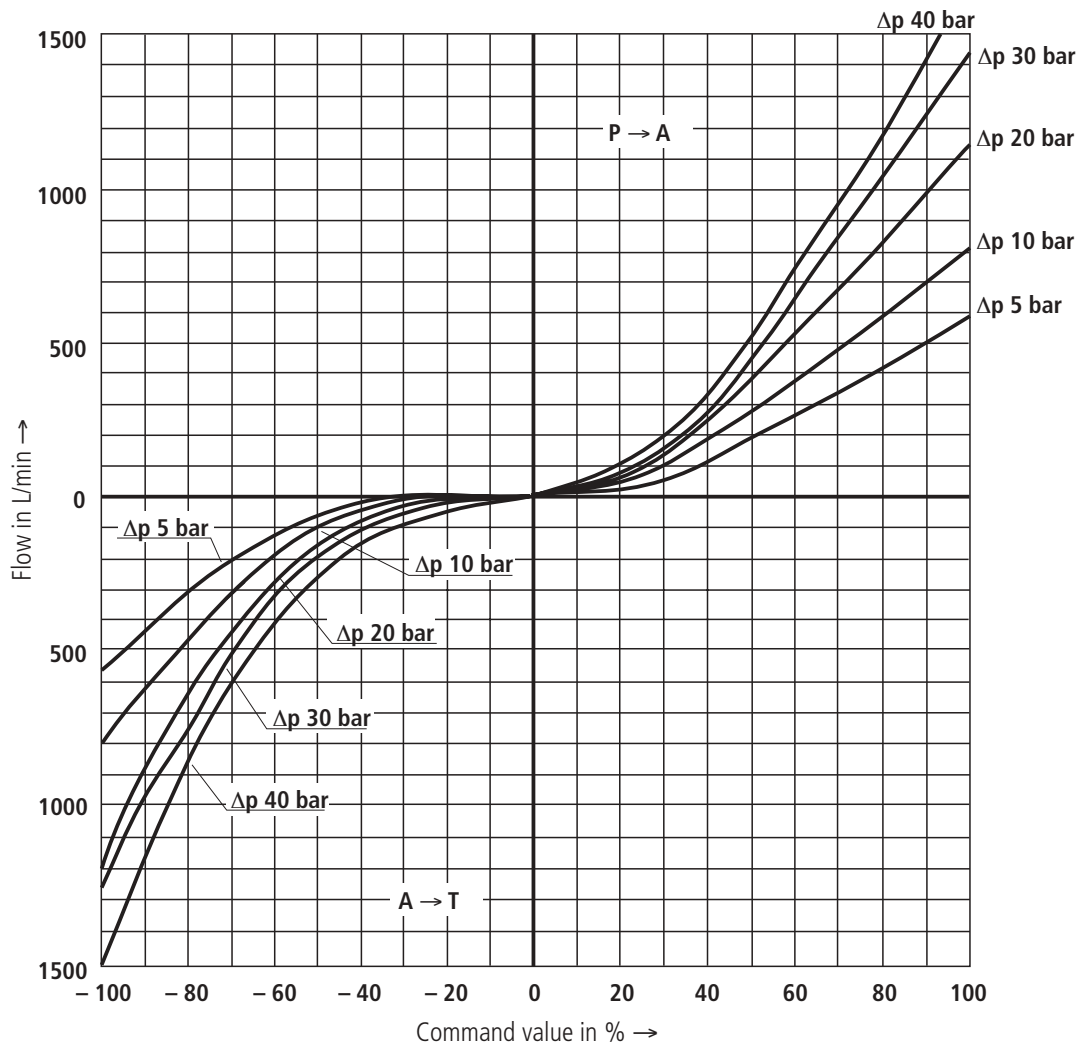

NS 50

Pressure-command value function

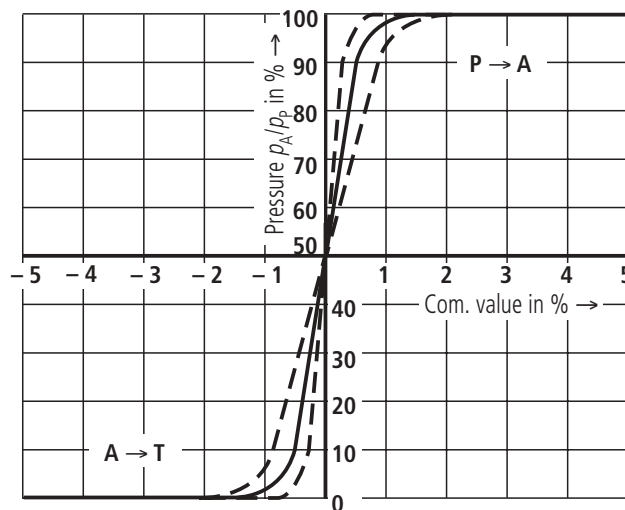

NS 50 Frequency response

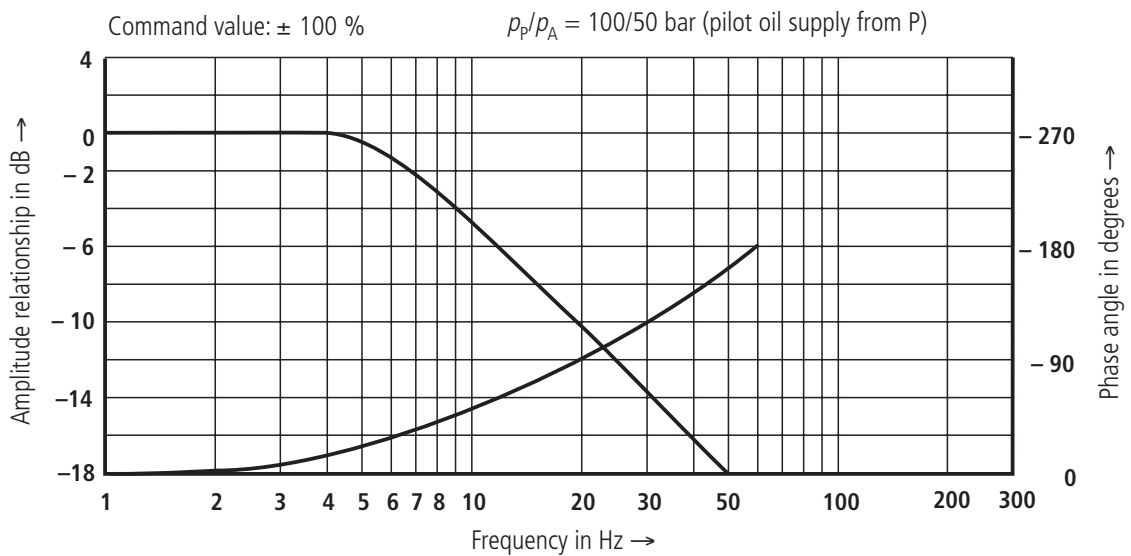
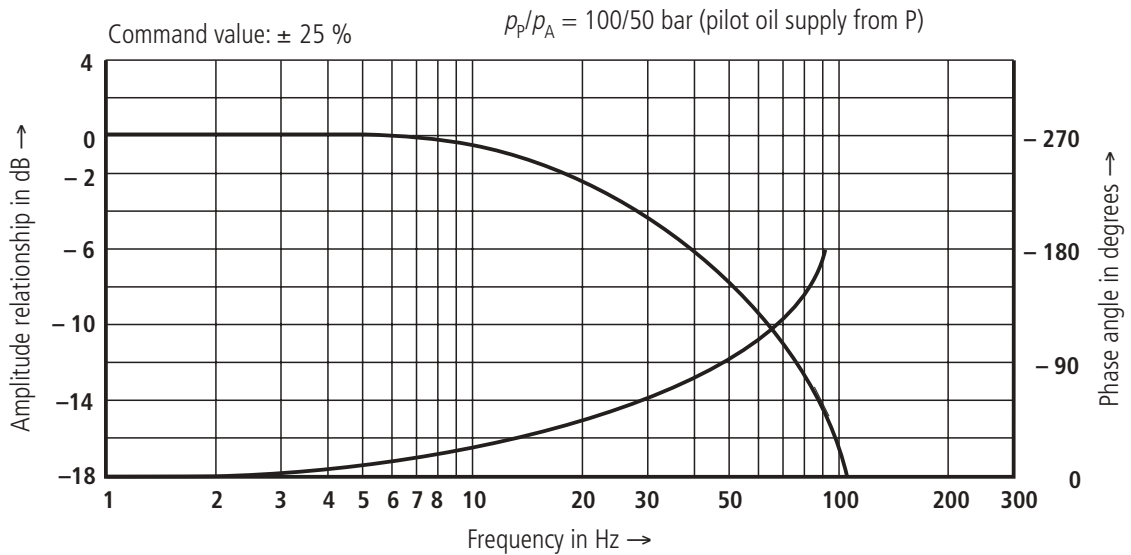
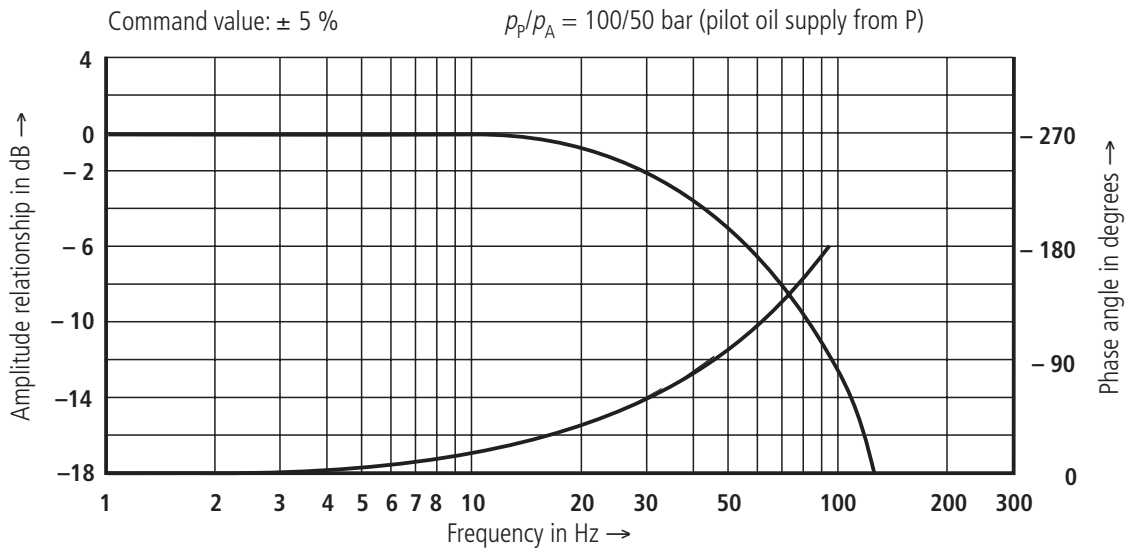

Unit dimensions (dimensions in mm)

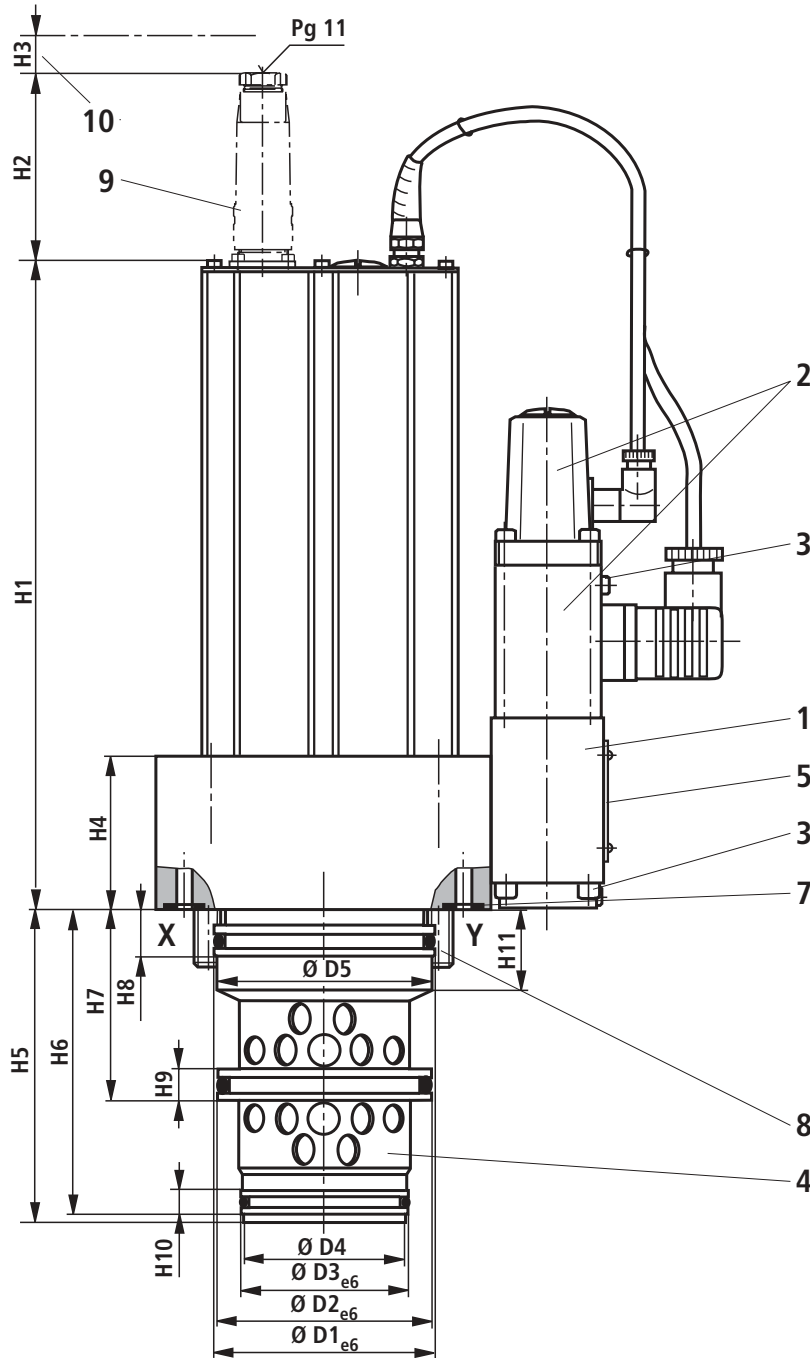

NS	25	32	50
L1	85	102	140
L2	103	103.5	140
L3	47	51	70
L4	58	70	100
L5	195	195.5	232
L6	45.5	45.5	45.5
L7	16	17	30
L8	47	47	47
L9	101	101	101
H1	269	273	275
H2	80	80	80
H3	15	15	15
H4	72	76	77.5
H5	102.9	99.9	164.8
H6	99.7	97.4	159.3
H7	67.9	57.9	104.8
H8	16.9	15.9	24.8
H9	11	13.5	18
H10	8.8	12.5	13.5
H11	30	–	45.8
Ø D1 _{e6}	45	60	90
Ø D2 _{e6}	43	58	87
Ø D3 _{e6}	34	55	68
Ø D4	32.5	53	66
Ø D5	44	–	88

For item explanation, required surface finish of the mating piece and installation dimensions see page 15.

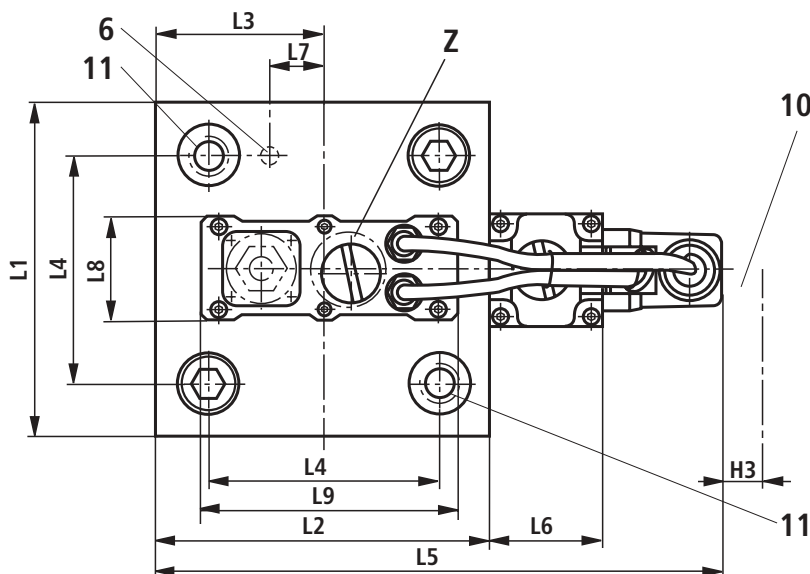

Z
Measurement sockets and zero point potentiometer

- Command value
- Act. value pilot stage
- Act. value main stage
- M0
- Zero point correction, spool of main stage flow
- P to A
- A to T

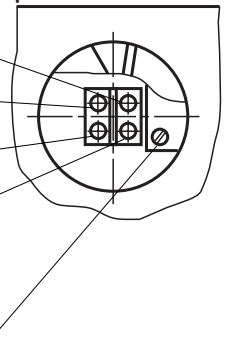

Installation dimensions (dimensions in mm)

NS	25	32	50
L1	85	102	140
L2	103	103.5	140
L3	47	51	70
L4±0,2	58	70	100
L5±0,1	29	35	50
L6±0,2	33	41	58
L7±0,2	16	17	30
H1+0,1	103	100	165
H2	56	43,5	87
H3	45	30	66
H4	15	16	40
H5	25	18	66
H6	2.5	3	3
H7±0,3	78	70.5	122
H8+0,3	89	85	143
H9	11.5	13.5	18
H10	2.5	3	3
H11	2.5	2.5	4
∅ D1 ^{H7}	45	60	90
∅ D2 ^{H7}	43	58	87
∅ D3 ^{H7}	34	55	68
max. ∅D4	20	30	35
max. ∅D5	20	24	35
max. ∅D6	6	8	10
D7	M12	M16	M20
∅ D8 ^{H13}	6	6	8
∅ D9 ^{+0,2}	33.7	54.7	67.7
T1	25	35	45
min. T2	10	10	10
V	0.03	0.03	0.04
W	0.05	0.1	0.1

For dimensions without tolerances, the general tolerances to DIN ISO 2768-mK apply

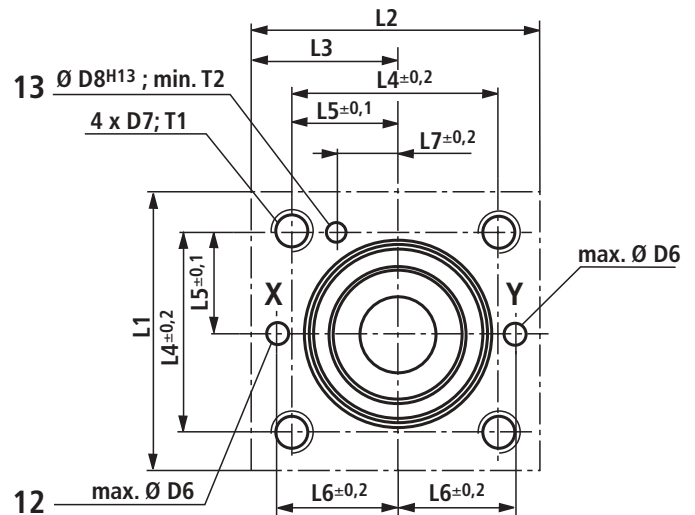
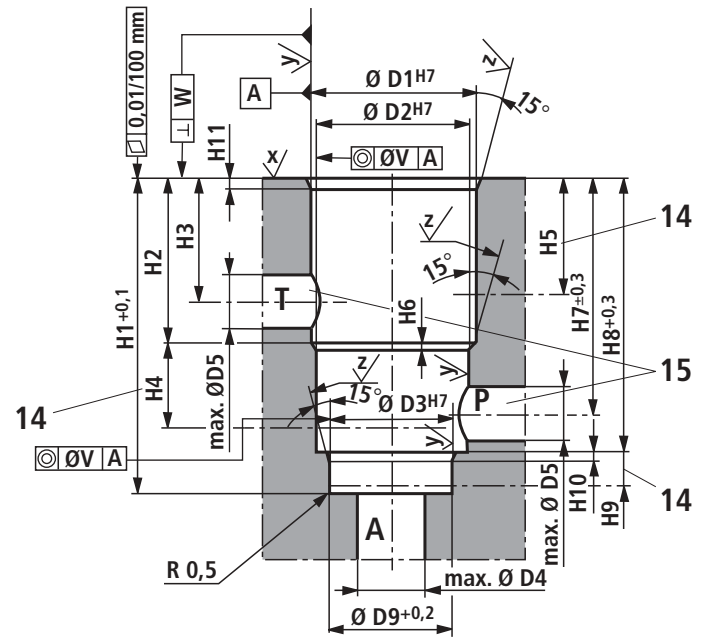

$$\sqrt{x/} = \sqrt{R_{\max} 4} \quad \sqrt{y/} = \sqrt{R_{\max} 8} \quad \sqrt{z/} = \sqrt{R_2 10}$$

- 1 Pilot control valve
- 2 Proportional solenoid with position transducer
- 3 Bleed screws
- 4 Sleeve
- 5 Name plate
- 6 Locating pin
- 7 Identical seal rings for ports X and Y
- 8 4 off valve fixing screws to DIN 912-10.9 (are included within the scope of supply)
 NS 25 M12 x 55 $M_A = 75 \text{ Nm}$
 NS 32 M16 x 90 $M_A = 170 \text{ Nm}$
 NS 50 M20 x 90 $M_A = 350 \text{ Nm}$
- 9 Plug-in connector – separate order, see page 5

- 10 Space required to remove the plug-in connector
- 11 Withdrawal thread 2 x M24 to remove valve from block (only Ns 50)
- 12 Connect port X with port P or connect externally
- 13 Locating pin hole
- 14 Depth of fit
- 15 Ports P and T can be arranged about the centre axis of port A. However, care must be taken to ensure that the fixing and control bores are not damaged.

Bosch Rexroth AG
Industrial Hydraulics

D-97813 Lohr am Main
Zum Eisengießer 1 • D-97816 Lohr am Main
Telefon 0 93 52 / 18-0
Telefax 0 93 52 / 18-23 58 • Telex 6 89 418-0
eMail documentation@boschrexroth.de
Internet www.boschrexroth.de

Bosch Rexroth Limited

Cromwell Road, St Neots,
Cambs, PE19 2ES
Tel: 0 14 80/22 32 56
Fax: 0 14 80/21 90 52
E-mail: info@boschrexroth.co.uk

The data specified above only serves to describe the product. No statements concerning a certain condition or suitability for a certain application can be derived from our information. The details stated do not release you from the responsibility for carrying out your own assessment and verification. It must be remembered that our products are subject to a natural process of wear and ageing.