

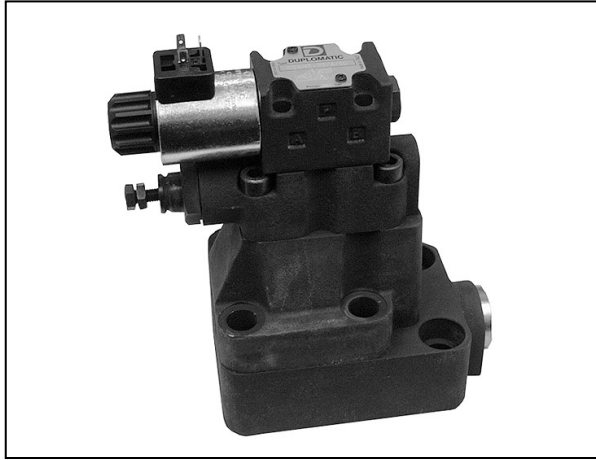

**DIPLOMATIC  
HYDRAULICS**

www.khadamathydraulic.com  
 Tell: 021-55882749  
 Tell: 021-33488178  
 Fax: 021-33488105

21 420/107 ED



**RQ\*M\*-P**  
 UNLOADING VALVE  
 WITH AUTOMATIC OR  
 SOLENOID OPERATED VENTING  
 (FOR CIRCUITS WITH ACCUMULATOR)  
 SERIES 51  
**RQRM\*-P**  
 FOR REMOTE PILOTING  
**RQAM\*-P**  
 WITH INCORPORATED CHECK VALVE

**SUBPLATE MOUNTING**

**HYDRAULIC SYMBOLS**

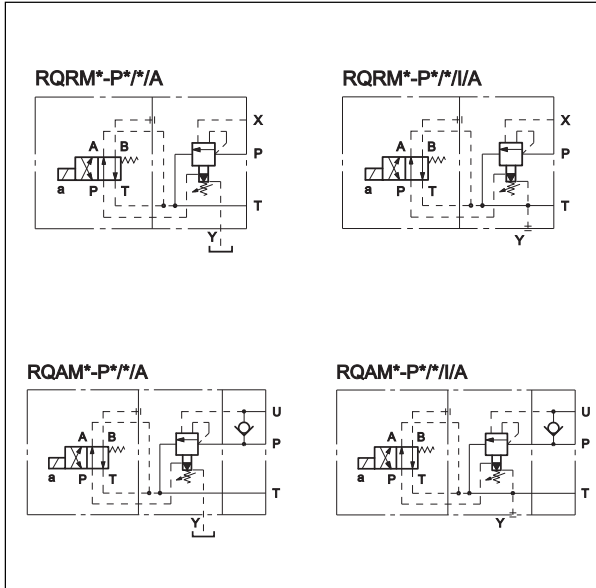

**OPERATING PRINCIPLE**

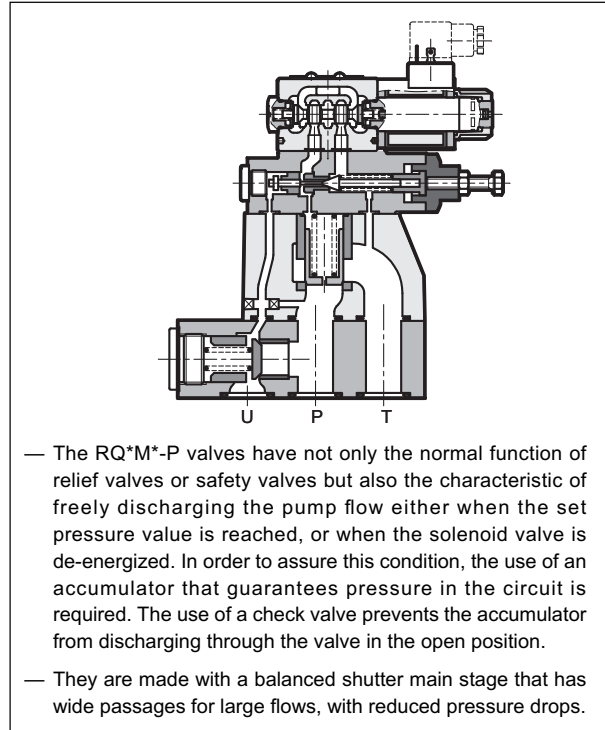

**PERFORMANCES** (measured with mineral oil of viscosity 36 cSt at 50°C)

		RQRM3-P	RQRM5-P	RQRM7-P	RQAM5-P	RQAM7-P
Maximum operating pressure	bar	350			320	
Maximum flow rate	l/min	200	400	500	400	500
Ambient temperature range	°C	-20 / +50				
Fluid temperature range	°C	-20 / +80				
Fluid viscosity range	cSt	10 ÷ 400				
Fluid contamination degree		According to ISO 4406:1999 class 20/18/15				
Recommended viscosity	cSt	25				
Mass	Kg	5	5,8	8	12	20,5

**NOTE:** for the solenoid valve DS3 characteristics see catalogue 41 150



# RQ\*M\*-P

## SERIES 51

### 1 - IDENTIFICATION CODE

<b>R</b>	<b>Q</b>	<b>M</b>	<b>-</b>	<b>P</b>	<b>/</b>	<b>/</b>	<b>A</b>	<b>/</b>	<b>/</b>	<b>/</b>	<b>51</b>	<b>-</b>	<b>K1</b>	<b>/</b>
----------	----------	----------	----------	----------	----------	----------	----------	----------	----------	----------	-----------	----------	-----------	----------

Unloading valve

Automatic venting for circuits with accumulator  
**R** = for remote piloting  
**A** = with embedded check valve (unavailable on size 3)

Solenoid valve for electrical unloading

Size: \_\_\_\_\_  
**3** = (RQRM3-P) ISO 6264-06-09-\*  
 (CETOP R06)  
**5** = (RQRM5-P) ISO 6264-08-13-\*  
 (CETOP R08)  
**5** = (RQAM5-P)  
**7** = (RQRM7-P) ISO 6264-10-17-\*  
 (CETOP R10)  
**7** = (RQAM7-P)

Subplate mounting \_\_\_\_\_

Pressure adjustment range: \_\_\_\_\_  
**3** = up to 70 bar  
**5** = up to 210 bar    **6** = up to 350 bar

**1** = pump switch on at 85% of the set value  
**2** = pump switch on at 70% of the set value

Unloading with de-energized solenoid \_\_\_\_\_

**I** = internal drainage (not possible when the backpressure on the return line is greater than 2 bar). Omit for external drainage.

**CM** = manual override, boot protected.  
 Omit for override integrated in the tube (**standard**)

Coil electrical connection: plug for connector type DIN 43650 (**standard**)

DC power supply  
**D12** = 12 V  
**D24** = 24 V  
**D48** = 48 V  
**D110** = 110 V  
**D220** = 220 V  
**D00** = valve without coils (see **NOTE**)

AC power supply  
**A24** = 24 V - 50 Hz  
**A48** = 48 V - 50 Hz  
**A110** = 110 V - 50 Hz / 120 V - 60 Hz  
**A230** = 230 V - 50 Hz / 240 V - 60 Hz  
**A00** = valve without coils (see **NOTE**)  
**F110** = 110 V - 60 Hz  
**F220** = 220 V - 60 Hz

Seals:  
**N** = NBR seals for mineral oil (**standard**)  
**V** = FPM seals for special fluids

Series No. (the overall and mounting dimensions remain unchanged from 50 to 59)

**M** = adjustment with SICBLOC knob (omit for adjustment with hexagonal head screw)

**NOTE:** The locking rings of the coils and the relevant O-Rings are supplied together with valves

### 2 - CHARACTERISTIC CURVES (values obtained with viscosity of 36 cSt at 50°C)

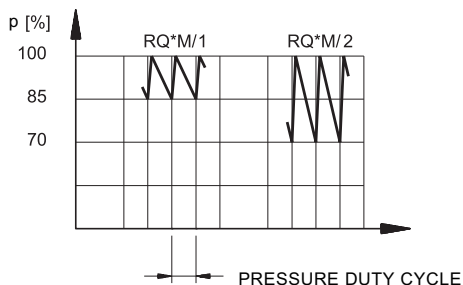
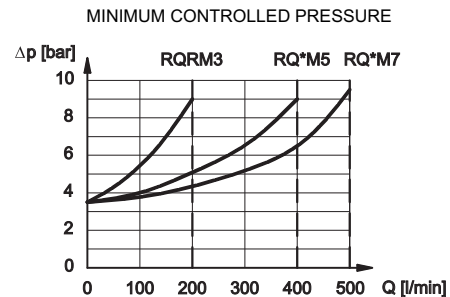
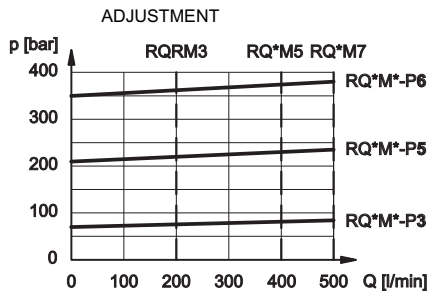

### 3 - HYDRAULIC FLUIDS

Use mineral oil-based hydraulic fluids HL or HM type, according to ISO 6743-4. For these fluids, use NBR seals (code N). For fluids HFDR type (phosphate esters) use FPM seals (code V). For the use of other kinds of fluid such as HFA, HFB, HFC, please consult our technical department.

Using fluids at temperatures higher than 80 °C causes a faster degradation of the fluid and of the seals characteristics.

The fluid must be preserved in its physical and chemical characteristics.



# RQ\*M\*-P

## SERIES 51

### 4 - RQRM3-P OVERALL AND MOUNTING DIMENSIONS

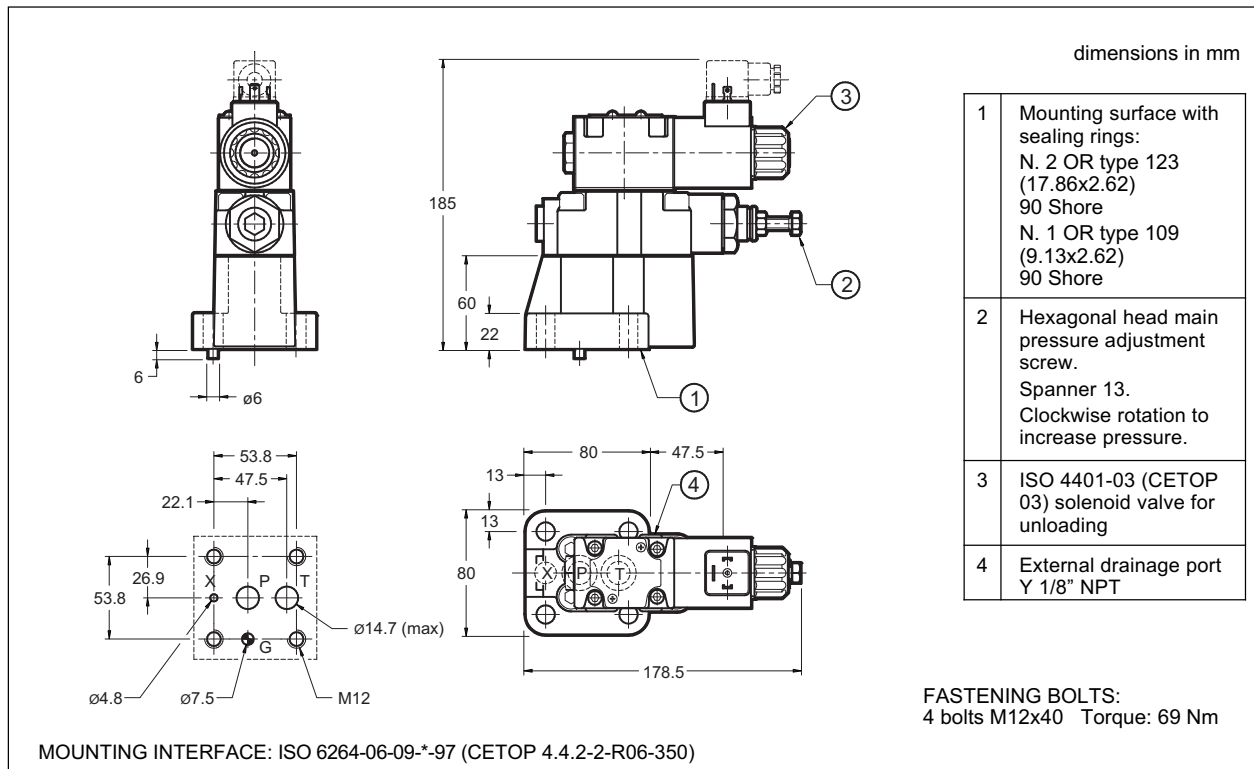

### 5 - RQRM5-P and RQRM7-P OVERALL AND MOUNTING DIMENSIONS

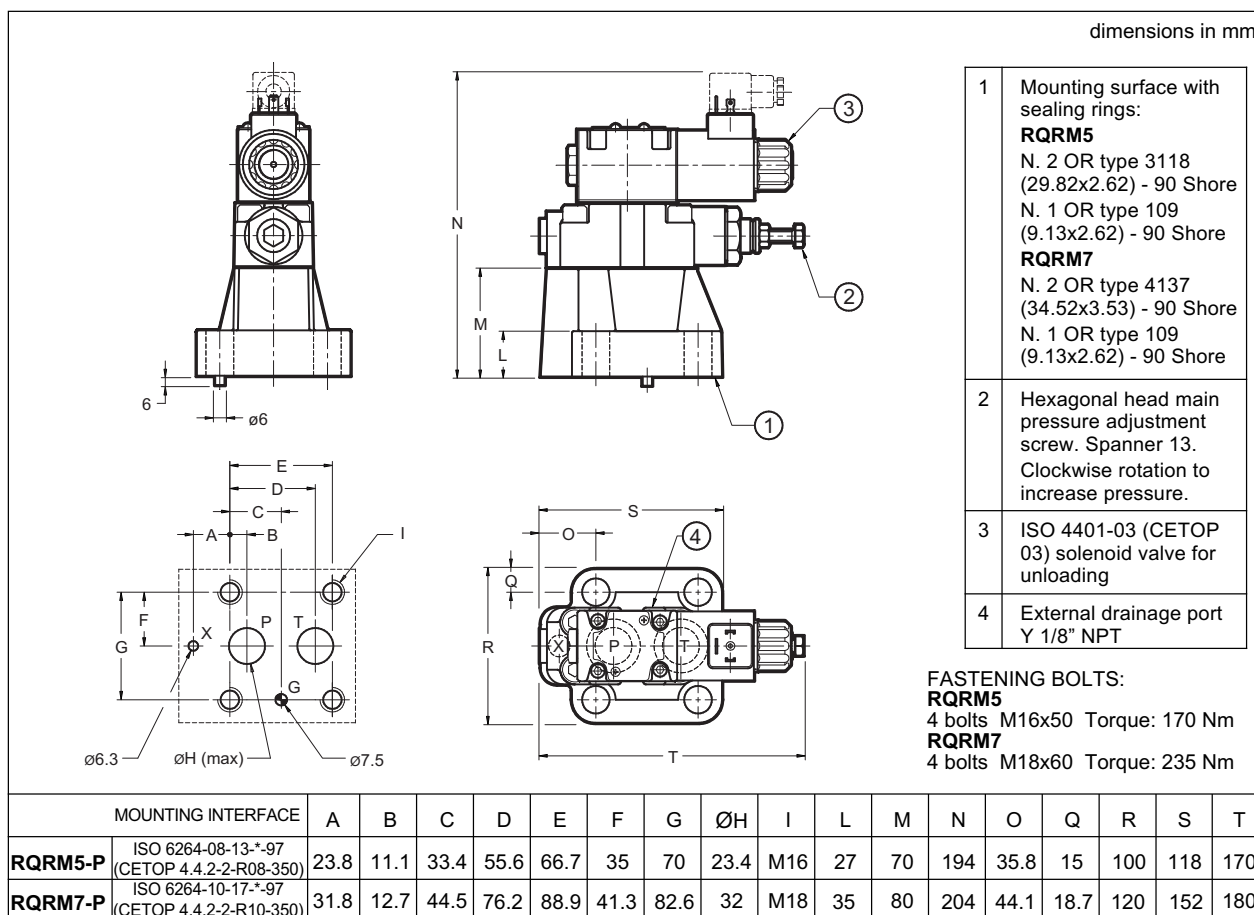



## 6 - RQAM5-P e RQAM7-P OVERALL AND MOUNTING DIMENSIONS

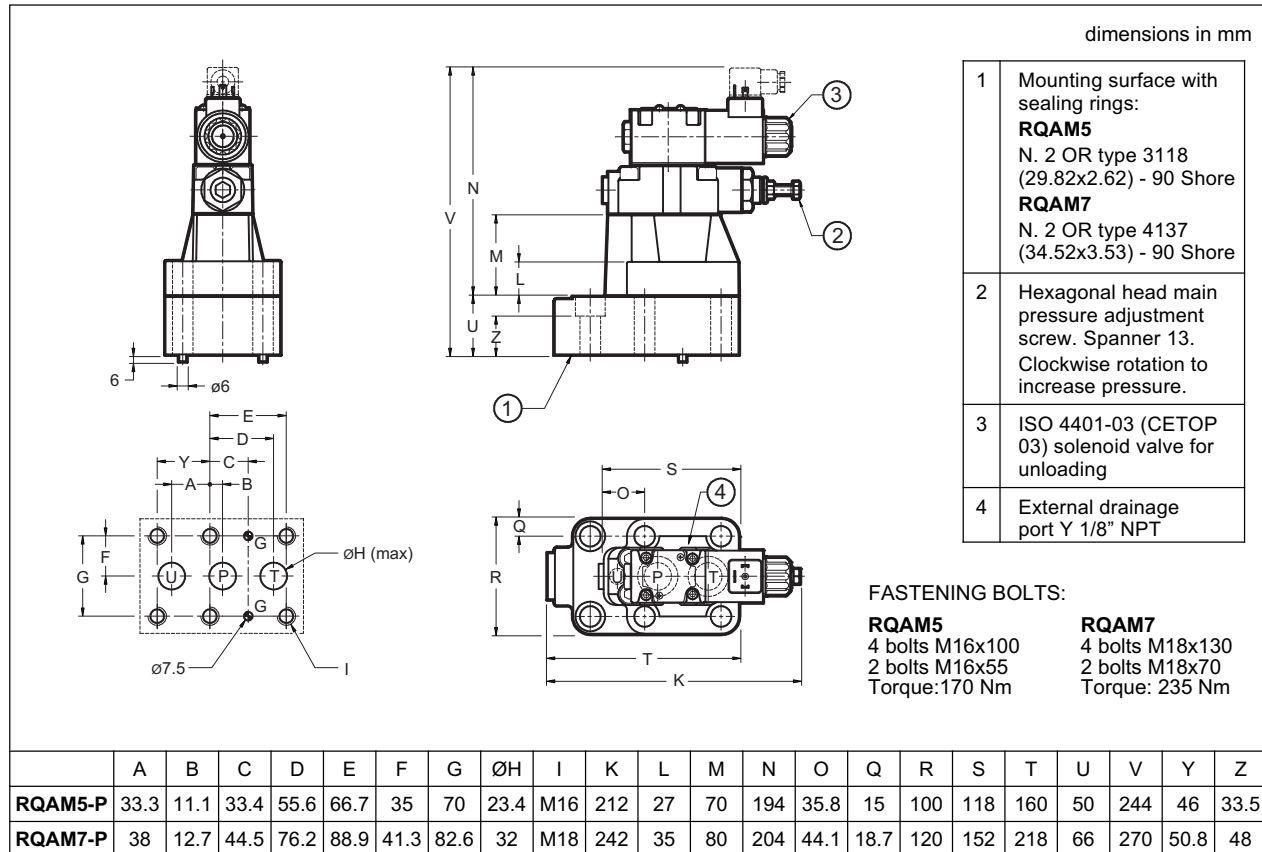

## 7 - ADJUSTMENT KNOB

The RQ\*M\*-P valves can be equipped with a SICBLOC adjustment knob. To operate it, push and rotate at the same time. To request this option, add: /M (see paragraph 1).

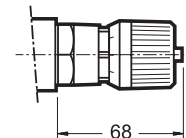

## 8 - ELECTRIC CONNECTORS

The solenoid valves are never supplied with connector. Connectors must be ordered separately. For the identification of the connector type to be ordered, please see catalogue 49 000.

## 9 - MANUAL OVERRIDE, BOOT PROTECTED: CM

Whenever the solenoid valve installation may involve exposure to atmospheric agents or utilization in tropical climates, use of the manual override, boot protected is recommended. Add the suffix **CM** to request this device (see paragraph 1). For overall dimensions see catalogue 41 150.

## 10 - SUBPLATES (see catalogue 51 000)

	<b>RQRM3-P</b>	<b>RQRM5-P</b>	<b>RQRM7-P</b>	<b>RQAM5-P</b>	<b>RQAM7-P</b>
Type	PMRQ3-AI4G rear ports	PMRQ5-AI5G rear ports	PMRQ7-AI7G rear ports	PMRQA5-AI5G rear ports	PMRQA7-AI7G rear ports
<b>P T U</b> port dimensions	1/2" BSP	1" BSP	1" 1/4 BSP	3/4" BSP	1" 1/4 BSP
<b>X</b> port dimensions	1/4" BSP	1/4" BSP	1/4" BSP	-	-

	<p><b>DIPLOMATIC OLEODINAMICA SpA</b>          20025 LEGNANO (MI) - P.le Bozzi, 1 / Via Edison          Tel. 0331/472111 - Fax 0331/548328</p>
--	--